

(No Model.)

2 Sheets—Sheet 1.

C. W. BROWN.  
MECHANICAL BOILER CLEANER.

No. 526,853.

Patented Oct. 2, 1894.

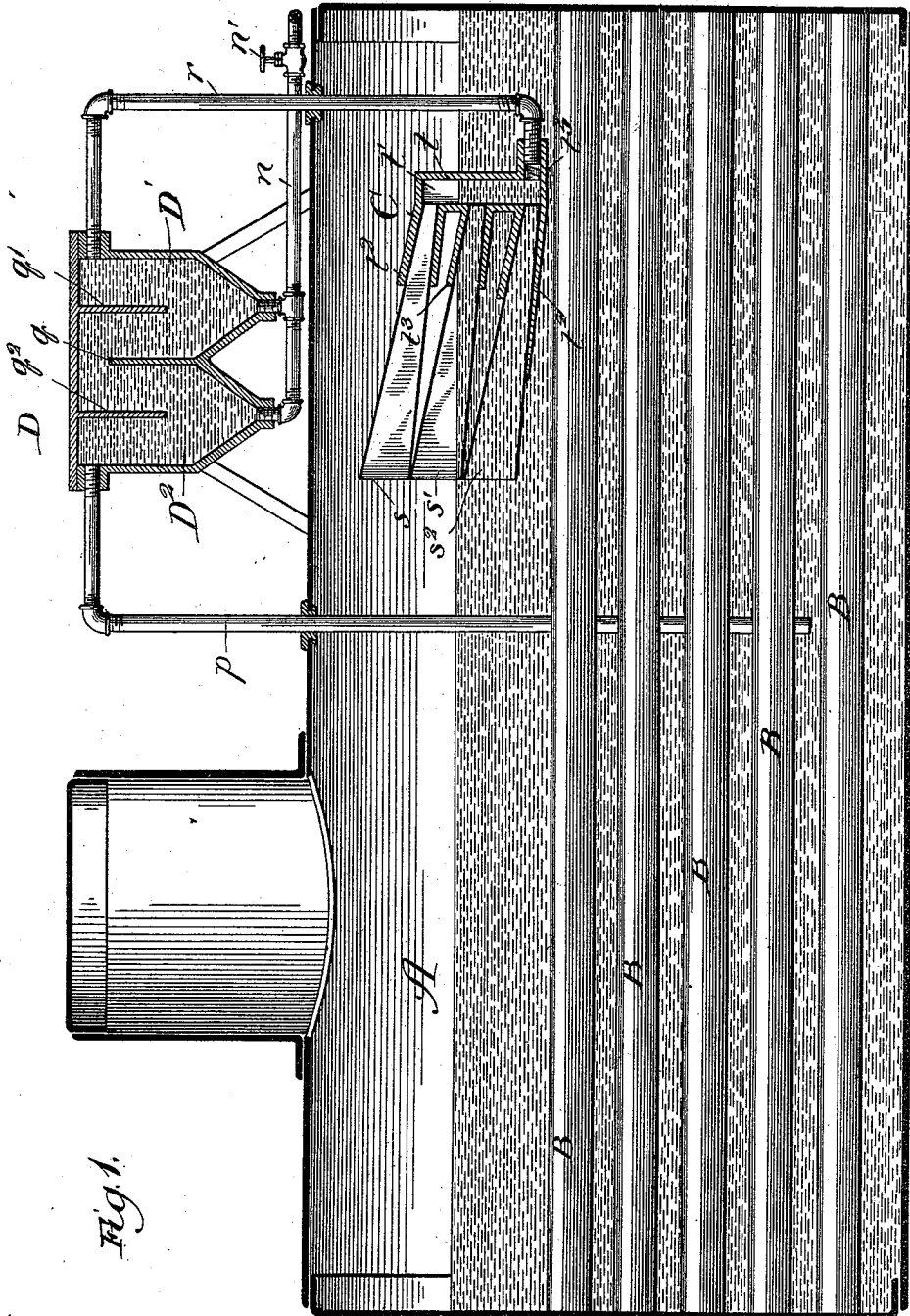

Witnesses:  
*Chas. E. Hayward,*  
*Lute J. H. Hester.*

Inventor:  
*Charles W. Brown.*  
 By *Dyrenforth and Dyrenforth*  
*Attys*

(No Model.)

2 Sheets—Sheet 2.

C. W. BROWN.  
MECHANICAL BOILER CLEANER.

No. 526,853.

Patented Oct. 2, 1894.

Fig. 2.

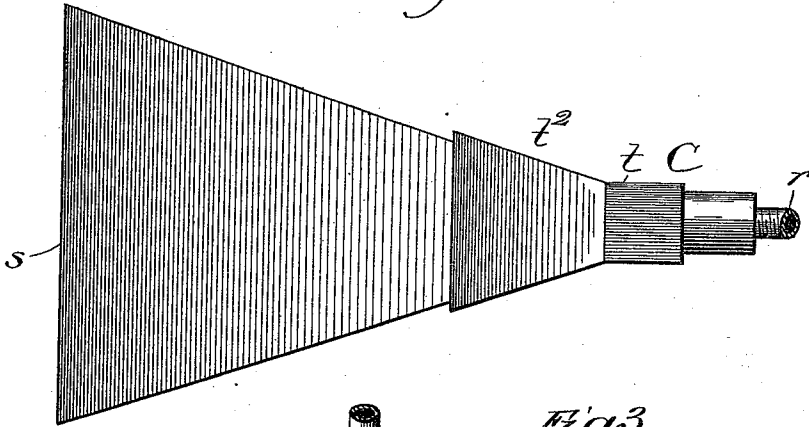

Fig. 3.

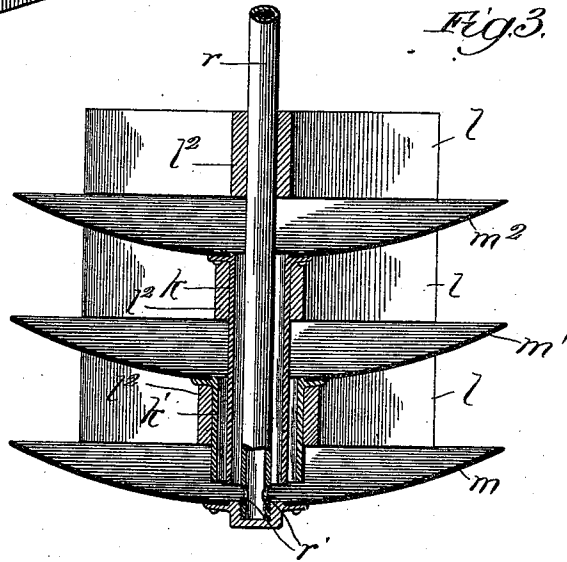
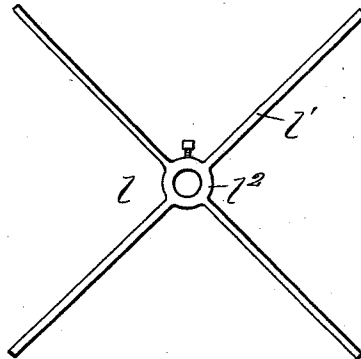

Fig. 4.



Witnesses:  
*Edw. C. Hayward*  
*Lucas J. Allen*

Inventor:  
*Charles W. Brown*  
By *Dyrenforth & Dyrenforth*  
*Attys*

# UNITED STATES PATENT OFFICE.

CHARLES W. BROWN, OF CHICAGO, ILLINOIS.

## MECHANICAL BOILER-CLEANER.

SPECIFICATION forming part of Letters Patent No. 526,853, dated October 2, 1894.

Application filed April 4, 1894. Serial No. 506,312. (No model.)

*To all whom it may concern:*

Be it known that I, CHARLES W. BROWN, a citizen of the United States, residing at Chicago, in the county of Cook and State of Illinois, have invented a new and useful Improvement in Mechanical Boiler-Cleaners, of which the following is a specification.

My invention relates to an improvement in boiler cleaners of the general class operating automatically, to skim from the water, in the boiler, the scum or sediment carried thereby, and to siphon it into a trap or mud-drum located without the boiler; a return pipe extending from the said trap or mud-drum back to the boiler below the water line, to complete the circulation.

The object of removing the sediment from the water is to prevent the formation of scale about the flues and on the inner surface of the boiler-shell, which scale, being a poor conductor of heat, necessitates increased firing and consequent consumption of fuel for the generation of steam, and tends furthermore to the injury of the boiler structure. Efficient means for the removal of scum and sediment, have come to be regarded as of vital importance in steam boilers, and while many types of automatic cleaners operating on the siphon principle have been devised and tried, none, so far as I am aware, are adapted to fill all the requirements necessary to remove the scum and sediment under all the varying conditions presented. To be effective, the skimmer should have an intake of comparatively large area, and extend across the path of the water current, which in a boiler always flows from the more active portion, or part where the water is subjected to the greatest heat, to the more quiescent portion of the boiler. A further requirement is that the skimmer shall be located with proper relation to the water-line of the boiler, for the reason that the scum and sediment separated from the body of water, as a result of boiling, are carried by the current, in its upper surface portion to a depth of from two to four inches. It is found in practice that the most effective skimmer is one having a comparatively wide horizontally flaring intake reaching across the current and adapted to direct the sediment skimmed from the water to the uptake pipe; but hitherto the cleaners have been provided with but one

such skimmer, or if with more than one, they have been located in the same horizontal plane. Such boiler cleaners to properly perform their functions require that the water in the boiler be kept, at all times, at the established water-line, so that the intake will always extend to the proper depth, depending upon the character of the water employed because, as is well known, some waters carry more sediment than others. Owing to the fact that it is next to impossible to so regulate the feed as to prevent fluctuations of the water surface, boiler cleaners constructed as described vary in their effectiveness as the water rises above or falls below the established water-line. To overcome this difficulty, skimmers have been provided with floats and pivoted at their rear ends to rise and fall at their intake ends with the water surface; but as the pivotal joints soon become clogged by the sediment in practice this structure has been generally discarded.

My object is to provide a mechanical boiler cleaner of the class described, which shall overcome the objections incident to the boiler cleaners hitherto provided, and operate with thorough effectiveness under the variations of the water level in the boiler.

In the drawings: Figure 1 is a longitudinal section of a steam boiler showing my improved boiler cleaner in operative position. Fig. 2 is a top plan view of the skimmer shown in Fig. 1. Fig. 3 is a vertical section of a modified form of skimmer; and Fig. 4, a plan view of a feature of the modified construction.

A is the shell of the boiler; and B the boiler flues.

C is the skimmer portion of my improved cleaner. The skimmer is formed with a body portion *t* presenting a vertical chamber or well *t'*, and three flaring mouths or projections *t<sup>2</sup> t<sup>3</sup> t<sup>4</sup>*, the lower lip of the mouth *t<sup>2</sup>* extending, preferably, some distance beyond the other lips. The mouths are located one above the other, and communicate with the well *t'*. They flare slightly in the vertical plane and much more decidedly in the horizontal plane. Fitting into the mouths *t<sup>2</sup> t<sup>3</sup> t<sup>4</sup>* are intake funnels *s s' s<sup>2</sup>*, respectively, which flare slightly in the vertical plane and decidedly in the horizontal plane, being so shaped that they present three horizontally elongated

open ends without space between them. At the base and back of the well  $t'$  is an opening  $t^5$  to which extends an uptake pipe  $r$ .

Outside the boiler shell, and preferably on the upper surface of the latter is a mud-drum or trap D, formed with two hopper-shaped chambers  $D' D^2$ . Extending upward between the chambers  $D' D^2$  nearly to the top of the trap is a partition  $q$ , and extending downward from the top plate of the trap to a plane below the top of the partition  $q$ , are partitions  $q' q^2$ , respectively. The uptake pipe  $r$  extends through the boiler shell to the upper part of the chamber  $D'$ , and extending from the upper part of the chamber  $D^2$  is a return pipe  $p$ , which passes through the boiler shell to a plane in the boiler some distance below the skimmer. At the lower ends of the chambers  $D' D^2$  are outlets communicating with a blow-off pipe  $n$  provided with a valve  $n'$ . The lower lips of the mouths  $t^2 t^3 t^4$  incline slightly upward, in the outward direction, whereby the lower surfaces of the funnels  $s s'$  incline slightly downward from the open ends to the well  $t'$ .

In practice the skimmer is so placed in the boiler as to extend with its open ends in the direction from which the current in the boiler flows, and with the base of the central funnel  $s'$  in the proper plane with relation to the established water-line to skim to the proper depth when the water in the boiler is at the established line. Thus if the water employed is comparatively clear the base of the funnel  $s'$  at its mouth may be two inches below the water-line, and if the water employed carries a great deal of sediment the said base may be located in a proportionately lower plane.

In operation as the water above the flues B flows in the backward direction it enters the open mouth of the funnel or funnels, which extend below the water surface, and as it can escape only in comparatively small volume to the well  $t'$ , it becomes comparatively quiescent and eddies backward. During the quiescent stage the sediment settles upon the backward inclined base of the funnel, and the repeated inward dashing of the water forces the sediment through the funnel to the well, into which it drops to the opening  $t^5$ . While the water in the boiler is boiling there is a constant flow through the skimmer to the uptake pipe  $r$  and trap D, the water from the trap returning to the boiler through the pipe  $p$ . All sediment dropping in the well  $t'$  therefore is carried by the current through the uptake pipe to the trap, where, owing to the size of the chamber  $D'$ , the water becomes comparatively quiescent, causing the sediment to precipitate. Any of the sediment carried by the current past the chamber  $D'$  will settle in the chamber  $D^2$ , so that the return water through the pipe  $p$  will be clear. As the sediment collects in the traps it may be blown off through the pipe  $n$  by opening the valve  $n'$ .

During the fluctuations of the water in the boiler, it will, when rising above the funnel  $s'$ ,

enter the funnel  $s$ ; and as it falls below the water-line it will enter only the funnel  $s^2$ . It is found in practice that three funnels located as described operate effectively to skim all sediment from the water even when undue fluctuations take place, because no matter how high or low the surface of the water may be one or two of the funnels are certain to be in position to take all the scum. It may be stated that where only one funnel is provided, having an intake mouth the size of the three shown, the water dashing into and out of the funnel would keep the sediment in such a state of agitation that it would not settle unless the surface of the water were only from two to four inches above the base of the funnel.

In the modified construction three dish-shaped plates are suspended upon the uptake pipe, and provided with deflectors or baffle-plates. The lower dish  $m$  may be screwed upon the lower end of the pipe  $r$ , the latter being provided with inlet openings  $r'$ , as shown. Resting upon the dish  $m$  is a deflector or baffle-plate  $l$ , comprising four radial arms  $l'$  and a hub  $l^2$ . Upon the baffle-plate  $l$  is a second dish  $m'$  surmounted by a second baffle-plate  $l$ ; and upon the latter is a third dish  $m^2$  surmounted by a third baffle-plate  $l$ . The hub of the upper baffle-plate fits around the uptake pipe  $r$ ; and the dish  $m^2$  has a central opening to which is fastened a downward extending sleeve  $k$ , which terminates just above the base of the dish  $m$ . The sleeve  $k$  affords an annular passage or well around the pipe  $r$ . The hub of the central baffle-plate fits around the sleeve  $k$ , and the dish  $m'$  has a central opening provided with a downward extending sleeve  $k'$  terminating just above the center of the dish  $m$ , and presenting a passage or well around the sleeve  $k$ ; and the hub of the lower baffle-plate  $l$  fits around the sleeve  $k'$ .

The skimmer shown in the modified construction is mounted in the boiler in the same way as the skimmer shown in the preferred construction. The arms  $l'$  of the baffle-plates extending in four directions will meet the current of water in the boiler no matter from which direction it comes, and the sediment dashed into the dishes between the arms  $l'$  will be deflected to the well. All sediment washed upon the dish  $m^2$  will pass down through the well  $k$  and be carried into the uptake pipe  $r$  through the openings  $r'$ , and all sediment settling upon the dish  $m'$  will be carried down through the well  $k'$  and pass out through the openings  $r'$ .

What I claim as new, and desire to secure by Letters Patent, is—

1. In a boiler-cleaner, a skimmer comprising a body-portion presenting a vertically disposed well having two or more inlet mouths, one above the other, a horizontally disposed outwardly flaring intake at each of said mouths, in combination with an uptake pipe, extending from the lower part of said well,

settling chamber and return-pipe, all constructed and arranged to operate substantially as and for the purpose set forth.

2. In a boiler-cleaner, a skimmer C, comprising a body-portion *t*, presenting a well *t'*, two or more inlet mouths, one directly above the other, terminating in reduced openings, at the said well, and having backward inclined bases extending to the well, and two or more horizontally disposed funnels, meeting at their adjacent outer edges, and extend-

ing into the said mouths, and having backward inclined base-portions, in combination with an up-take pipe, extending from the lower part of the well, settling chamber and return pipe, all constructed and arranged to operate substantially as and for the purpose set forth.

CHARLES W. BROWN.

In presence of—

M. J. FROST,

W. U. WILLIAMS.