

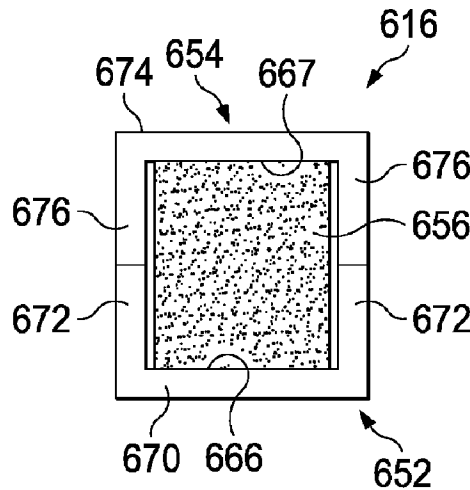

(86) Date de dépôt PCT/PCT Filing Date: 2017/04/25
 (87) Date publication PCT/PCT Publication Date: 2017/11/02
 (45) Date de délivrance/Issue Date: 2022/05/24
 (85) Entrée phase nationale/National Entry: 2018/10/25
 (86) N° demande PCT/PCT Application No.: US 2017/029308
 (87) N° publication PCT/PCT Publication No.: 2017/189510
 (30) Priorité/Priority: 2016/04/25 (US62/327,035)

(51) Cl.Int./Int.Cl. *F41B 5/12* (2006.01),
F41B 5/00 (2006.01)
 (72) Inventeurs/Inventors:
MARRIOTT, DOUGLAS LEWIS, US;
READ, SHANNON R., US;
HAYNES, CLINTON A., US;
MORROW, DANIEL L., US;
STUMPH, HERBERT E., III, US
 (73) Propriétaire/Owner:
STRESS ENGINEERING SERVICES, INC., US
 (74) Agent: PARLEE MCLAWS LLP

(54) Titre : BRANCHE D'ARC ET ARC POUR LE TIR A L'ARC L'UTILISANT
 (54) Title: BOW LIMB AND ARCHERY BOW USING SAME



(57) **Abrégé/Abstract:**

A limb for an archery bow is provided. The limb includes an outer elongate member, an inner elongate member, and a core member. The outer elongate member is formed of a first material and includes an interior surface and an exterior surface. The inner elongate member is formed of a second material and includes an interior surface and an exterior surface. The core member is formed of a third material and is sandwiched between the outer elongate member and the inner elongate member. The core member is coupled with at least a portion of each of the interior surfaces of the outer elongate member and the inner elongate member. The outer elongate member and the inner elongate member are configured to move relative to each other when the limb is bent. The first material and the second material are each stiffer than the third material.

(12) INTERNATIONAL APPLICATION PUBLISHED UNDER THE PATENT COOPERATION TREATY (PCT)

(19) World Intellectual Property
Organization
International Bureau



(10) International Publication Number
WO 2017/189510 A1

(43) International Publication Date
02 November 2017 (02.11.2017)

(51) International Patent Classification:

F41B 5/00 (2006.01) *F41B 5/10* (2006.01)

(21) International Application Number:

PCT/US2017/029308

(22) International Filing Date:

25 April 2017 (25.04.2017)

(25) Filing Language:

English

(26) Publication Language:

English

(30) Priority Data:

62/327,035 25 April 2016 (25.04.2016) US

(72) Inventors; and

(71) Applicants: **MARRIOTT, Douglas, Lewis** [US/US]; c/o Stress Engineering Services, Inc., 7030 Stress Engineering Way, Mason, OH 45040 (US). **READ, Shannon, R.** [US/US]; c/o Stress Engineering Services, Inc., 7030 Stress Engineering Way, Mason, OH 45040 (US). **HAYNES, Clinton, A.** [US/US]; c/o Stress Engineering Services, Inc., 7030 Stress Engineering Way, Mason, OH 45040 (US). **MORROW, Daniel, L.** [US/US]; c/o Stress Engineering Services, Inc., 7030 Stress Engineering Way, Mason, OH 45040 (US). **STUMPH, Herbert, E., III** [US/US]; c/o Stress Engineering Services, Inc., 7030 Stress Engineering Way, Mason, OH 45040 (US).

(74) Agent: **VOIT, Seth, A.** et al.; Ulmer & Berne LLP, 600 Vine Street, Suite 2800, Cincinnati, OH 45202 (US).

(81) Designated States (unless otherwise indicated, for every kind of national protection available): AE, AG, AL, AM, AO, AT, AU, AZ, BA, BB, BG, BH, BN, BR, BW, BY, BZ, CA, CH, CL, CN, CO, CR, CU, CZ, DE, DJ, DK, DM, DO, DZ, EC, EE, EG, ES, FI, GB, GD, GE, GH, GM, GT, HN, HR, HU, ID, IL, IN, IR, IS, JP, KE, KG, KH, KN, KP, KR, KW, KZ, LA, LC, LK, LR, LS, LU, LY, MA, MD, ME, MG,

MK, MN, MW, MX, MY, MZ, NA, NG, NI, NO, NZ, OM, PA, PE, PG, PH, PL, PT, QA, RO, RS, RU, RW, SA, SC, SD, SE, SG, SK, SL, SM, ST, SV, SY, TH, TJ, TM, TN, TR, TT, TZ, UA, UG, US, UZ, VC, VN, ZA, ZM, ZW.

(84) Designated States (unless otherwise indicated, for every kind of regional protection available): ARIPO (BW, GH, GM, KE, LR, LS, MW, MZ, NA, RW, SD, SL, ST, SZ, TZ, UG, ZM, ZW), Eurasian (AM, AZ, BY, KG, KZ, RU, TJ, TM), European (AL, AT, BE, BG, CH, CY, CZ, DE, DK, EE, ES, FI, FR, GB, GR, HR, HU, IE, IS, IT, LT, LU, LV, MC, MK, MT, NL, NO, PL, PT, RO, RS, SE, SI, SK, SM, TR), OAPI (BF, BJ, CF, CG, CI, CM, GA, GN, GQ, GW, KM, ML, MR, NE, SN, TD, TG).

Published:

— with international search report (Art. 21(3))

(54) Title: BOW LIMB AND ARCHERY BOW USING SAME

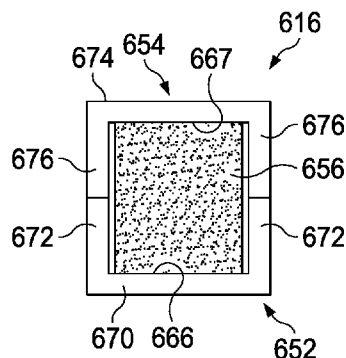

FIG. 17

(57) Abstract: A limb for an archery bow is provided. The limb includes an outer elongate member, an inner elongate member, and a core member. The outer elongate member is formed of a first material and includes an interior surface and an exterior surface. The inner elongate member is formed of a second material and includes an interior surface and an exterior surface. The core member is formed of a third material and is sandwiched between the outer elongate member and the inner elongate member. The core member is coupled with at least a portion of each of the interior surfaces of the outer elongate member and the inner elongate member. The outer elongate member and the inner elongate member are configured to move relative to each other when the limb is bent. The first material and the second material are each stiffer than the third material.



WO 2017/189510 A1

BOW LIMB AND ARCHERY BOW USING SAME

[0001] Intentionally left blank.

TECHNICAL FIELD

[0002] The apparatus and methods described below generally relate to a pair of bow limbs for an archery bow such as a crossbow.

BACKGROUND

[0003] Conventional crossbows have bow limbs that are formed of synthetic composite materials, such as fiber reinforced plastic (FRP), which can include carbon-fiber reinforced plastic and/or fiberglass. These synthetic composite materials are expensive, difficult to manufacture, and subject to inconsistencies during manufacturing which can affect the performance of the crossbow.

SUMMARY

[0004] In accordance with one embodiment, a limb for an archery bow is provided. The limb comprises an outer elongate member, an inner elongate member, and a core member. The outer elongate member is formed of a first material and comprises an interior surface and an exterior surface. The inner elongate member is formed of a second material and comprises an

interior surface and an exterior surface. The core member is formed of a third material and is sandwiched between the outer elongate member and the inner elongate member. The core member is coupled with at least a portion of each of the interior surfaces of the outer elongate member and the inner elongate member. The outer elongate member and the inner elongate member are configured to move relative to each other when the limb is bent. The first material and the second material are each stiffer than the third material.

BRIEF DESCRIPTION OF THE DRAWINGS

[0005] It is believed that certain embodiments will be better understood from the following description taken in conjunction with the accompanying drawings in which:

[0006] FIGS. 1A-1B depict various views of a crossbow according to one embodiment;

[0007] FIGS. 1C-1E depict various views of a bow limb of the crossbow of FIGS. 1A-1B;

[0008] FIG. 1F depicts a plot depicting a relationship between pull distance and pull force of a bow string of the crossbow of FIGS. 1A-1E;

[0009] FIGS. 2A-2I depict various views of a crossbow and a bow limb for the crossbow according to another embodiment;

[0010] FIG. 2J depicts a bow limb of the crossbow of FIGS. 2A-2I according to another embodiment;

[0011] FIG. 2K depicts a bow limb of the crossbow of FIGS. 2A-2I according to another embodiment;

[0012] FIGS. 3A-3D depict various views of a bow limb of a crossbow according to yet another embodiment;

[0013] FIGS. 4A-4D depict various views of a bow limb of a crossbow according to still yet another embodiment;

[0014] FIG. 5 depicts a view of a crossbow according to another embodiment. ;

[0015] FIG. 6 depicts a side isometric view of a bow limb of a crossbow according to still yet another embodiment;

[0016] FIG. 7 depicts a top isometric view of the bow limb of FIG. 6;

[0017] FIG. 8 depicts a left side view of the bow limb of FIG. 6;

[0018] FIG. 9 depicts a bottom view of the bow limb of FIG. 6;

[0019] FIG. 10 depicts a right side view of the bow limb of FIG. 6;

[0020] FIG. 11 depicts an end view of the bow limb of FIG. 6 taken from the perspective of line 11-11 in FIG. 9;

[0021] FIG. 12 depicts an end view of the bow limb of FIG. 6 taken from the perspective of line 12-12 in FIG. 9;

[0022] FIG. 13 depicts a front isometric view of a portion of a right side of a crossbow that incorporates two bow limbs of FIG. 6;

[0023] FIG. 14 depicts a plot of the relationship between a load provided to the bow limb of FIG. 6 and the resulting deflection of the bow limb;

[0024] FIG. 15 depicts a side view of a bow limb of a crossbow according to still yet another embodiment;

[0025] FIG. 16 depicts an end view of the bow limb of FIG. 15 taken from the perspective of line 16-16 in FIG. 15;

[0026] FIG. 17 depicts an end view of the bow limb of FIG. 15 taken from the perspective of line 17-17 in FIG. 15;

[0027] FIG. 18 depicts a side view of an outer elongate member of the bow limb of FIG. 15;

[0028] FIG. 19 depicts an end view of the outer elongate member of FIG. 18 taken from the perspective of line 19-19 in FIG. 18;

[0029] FIG. 20 depicts an end view of the outer elongate member of FIG. 18 taken from the perspective of line 20-20 in FIG. 18;

[0030] FIG. 21 depicts a side view of an inner elongate member of the bow limb of FIG. 15;

[0031] FIG. 22 depicts an end view of the inner elongate member of FIG. 21 taken from the perspective of line 22-22 in FIG. 21;

[0032] FIG. 23 depicts a side isometric view of a bow limb of a crossbow according to still yet another embodiment;

[0033] FIG. 24 depicts a side isometric view of the bow limb of FIG. 23 in each of a straightened position and a bent position;

[0034] FIG. 25 depicts a side isometric view of a bow limb of a crossbow according to still yet another embodiment;

[0035] FIG. 26 depicts a side isometric view of the bow limb of FIG. 25 in each of a straightened position and a bent position;

[0036] FIG. 27 depicts a plot of the relationship between a tip force provided to the bow limb of FIGS. 23-26 and the resulting tip deflection of the bow limb;

[0037] FIG. 28 depicts a side isometric view of a bow limb of a crossbow according to still yet another embodiment;

[0038] FIG. 29 depicts a side isometric view of a bow limb of a crossbow according to still yet another embodiment;

[0039] FIG. 30 depicts a front isometric view of a portion of a right side of a crossbow that incorporates two bow limbs according to still yet another embodiment;

[0040] FIG. 31 depicts a front isometric view of a portion of a right side of a crossbow that incorporates two bow limbs according to still yet another embodiment;

[0041] FIG. 32 depicts a front view of an embedded spring of the bow limbs of FIG. 31 with the embedded spring shown in a relaxed state; and

[0042] FIG. 33 depicts a front view of an embedded spring of the bow limbs of FIG. 31 with the embedded spring shown in a bent state.

DETAILED DESCRIPTION

[0043] Selected embodiments are hereinafter described in detail in connection with the views and examples of FIGS. 1A-1F, 2A-2K, 3A-3D, 4A-4D, and 5-33. A crossbow 10 in accordance with one embodiment is generally depicted in FIGS. 1A and 1B. The crossbow 10 can include a stock 12, a pair of pulleys 14 (e.g., cams) rotatably coupled to the stock 12, and a pair of bow limbs 16. Each of the bow limbs 16 can be rotatably coupled with the stock 12 at a proximal end 18 such that the bow limbs 16 are rotatable with respect to the stock 12 about respective limb axes A1 between a relaxed position (FIG. 1A) and a loaded position (FIG. 1B). A bow string 20 can be attached to distal ends 22 of the bow limbs 16 and routed from the distal ends 22, around the pulleys 14, and around a stop portion 24 (FIG. 1A). The bow string 20 can include a nocking portion 26 that is routed around the stop portion 24. It is to be appreciated that any of a variety of suitable alternative stocks can be provided for use with the bow limbs 16.

[0044] A spring 28 can be disposed at each of the distal ends 22 of the bow limbs 16 and can facilitate rotatable coupling of the bow limbs 16 to the stock 12. The springs 28 can be configured to bias the bow limbs 16 into the relaxed position. When the bow limbs 16 are in the relaxed position, as illustrated in FIG. 1A, a nock of an arrow (e.g., 136 in FIG. 2A) can be engaged with the nocking portion 26 of the bow string 20 and the arrow can be laid between the springs 28 to load the arrow into the crossbow 10. The arrow can then be pulled rearwardly (e.g., in the direction of arrow P) which can pull the bow limbs 16 into the loaded position, and a catch (e.g., 140 in FIG. 2A) can hold the nocking portion 26 in position. To fire the arrow, a user can pull a trigger (e.g., 142 in FIG. 2A) which releases the catch. The springs 28 can pull the bow limbs 16 towards the relaxed position which can pull the nocking portion 26 forwardly (in the opposite direction as arrow P) which can fire the arrow.

[0045] The springs 28 can be provided in a torsion spring type arrangement. For example, referring now to FIGS. 1C-1E, one of the springs 28 is shown to include a spindle 30 that is flexibly coupled with an outer collar 32 by a flexible body 34. In one embodiment, the flexible body 34 can comprise an elastomeric material, such as a vulcanized isoprene rubber (e.g., natural rubber), for example. The spindle 30 can be rigidly coupled with the stock 12 and the outer collar 32 can be rigidly coupled with the rest of the bow limb 16. When the bow limb 16 is moved from the relaxed position to the loaded position, the spindle 30 pivots with respect to the outer collar 32 (in the direction of arrow T). The flexible body 34 opposes this pivoting, thus biasing the bow limb 16 towards the relaxed position. When the trigger (not shown) is actuated, the flexible body 34 facilitates pivoting of the spindle 30 (in a direction opposite arrow T) to pull the bow limb 16 towards the relaxed position, thus firing the arrow. It is to be appreciated that the springs 28 can be provided in any of a variety of arrangements that facilitate biasing of the bow limbs 16 towards the relaxed position. It is also to be appreciated that since the springs 28 provide propulsion for the arrow, the rest of the bow limbs 16 can be formed of a material that is less expensive, more durable, and easier to make than CFRP and/or fiberglass, such as high strength steel (HSS).

[0046] The elastomeric material used for the springs 28 and the HSS used for the bow limbs 16 can be more cost effective and easier to manufacture than conventional CFRP and/or fiberglass bow limbs. In addition, the material properties of the elastomeric material used for the springs 28 and the HSS used for the bow limbs 16 can be more easily controlled during manufacturing. As a result, the performance of the springs 28 and the bow limbs 16 are more predictable, which can reduce or eliminate the need to tune or match performance characteristics of the bow limbs as is oftentimes the case with CFRP and/or fiberglass bow limbs.

[0047] It is to be appreciated that the effectiveness of the springs 28 can be affected by the shape of the flexible material as well as two of its material properties – the maximum allowable stress (σ) and the Stiffness modulus (E). The maximum allowable stress (σ) can be described as the amount of load that the flexible/elastic material of the springs 28 can support before breaking. The Stiffness modulus (E) can be described as the amount of deformation of the material upon the application of an applied load. It is also to be appreciated that the energy storage capacity of a spring can be defined as the Specific Strain Energy (SSE). The formula for SSE can be defined by the following equation:

$$SSE = \frac{\eta \times \sigma^2}{E}$$

where η is the efficiency factor of the flexible material. The higher the efficiency factor, the better the material is able to store energy which can result in a more lightweight design.

[0048] Referring now to FIG. 1F, a plot is depicted showing the relationship between the pull distance (d) and the pull force (P) of the bow string 20 as a result of the springs 28 as compared with a simple spring. As illustrated, initially, as the bow string 20 is pulled rearwardly, the force required to pull the bow string 20 increases. Eventually, as the bow string 20 continues rearwardly, the force required to pull the bow string 20 stays substantially the same and then decreases as the nocking portion 26 (FIGS. 1A and 1B) approaches the catch. This eventual decrease in required force is called *détente* and can reduce fatigue in a user. By comparison, the force on the string of a crossbow with a simple string increases through the travel of the spring rearwardly which can encourage fatigue in a user.

[0049] FIG. 2A illustrates an alternative embodiment of a crossbow 110 that is similar to or the same as in many respects as the crossbow 10 of FIGS. 1A-1E. For example, the crossbow 110 can have a stock 112, a pair of pulleys 114, a pair of bow limbs 116, and a bow string 120. However, a proximal end 118 of each of the bow limbs 116 can be rigidly coupled with the stock 112, and the pulleys 114 can be disposed at respective distal ends 122 of the bow limbs 116. The bow string 120 can be routed around the pulleys 114. When the bow limbs 116 are in the relaxed position (not shown), a nock 136 of an arrow 138 can be engaged with a nocking portion 126 of the bow string 120. The arrow 138 can then be pulled rearwardly which can pull the bow limbs 116 into the loaded position as shown in FIG. 2A. The nocking portion 126 of the bow string 120 can engage a catch 140 which can hold the nocking portion 126 in position until released by a trigger 142.

[0050] Referring now to FIGS. 2B-2J, each of the bow limbs 116 can be formed of a plurality of leaf plates 144 that can have different lengths (as shown in FIGS. 2B and 2G) and can be stacked on top of each other (as shown in FIGS. 2C and 2G) to form each bow limb 116. The leaf plates 144 can be stacked in such a manner that the outermost leaf plate 144 (the leaf plate 144 that extends along the front most portion of the crossbow 110 when the bow limbs 116 are in the relaxed position) is the longest and overlies shorter leaf plates 144. Each of the leaf plates 144 is arranged such that it is shorter than the one that overlies it. Each of the leaf plates 144 can have a cross-sectional profile that resembles a top hat. More particularly, each of the leaf plates 144 can have an upper portion 146 and a pair of lower edge portions 148 that are spaced from each other and substantially parallel with each other. A pair of wall portions 150 can extend between the upper portion 146 and the pair of lower edge portions 148. The pair of wall portions 150 can be spaced from each other and substantially parallel with each other. This

top-hat type arrangement provides more material in high stress locations than in low stress locations (see FIG. 2I). It is to be appreciated that each of the leaf plates 144 can be configured to be slightly smaller or larger than the adjacent leaf plates 144 to accommodate stacking (see FIG. 2D). Although the bow limbs 116 are shown in FIG. 2A to be arranged such that the upper portion 146 extends along the front most portion of the crossbow 110, it is appreciated that the bow limbs 116 can alternatively be arranged in a reverse orientation such that the pair of lower edge portions 148 extend along the front most portion of the crossbow 110.

[0051] The leaf plates 144 can be formed of a metal or metal alloy such as high strength steel (HSS), Beryllium Copper, Phosphor Bronze, and/or Titanium, for example. In one embodiment, all of the leaf plates 144 can be formed of the same material while in another embodiment, some or all of the leaf plates can be formed of different material. It is to be appreciated that by forming the leaf plates 144 from a metal or metal alloy, the bow limbs 116 can be less expensive, more durable, and easier to make than CFRP and/or fiberglass. In addition, the bow limbs 116 can be more cost effective, easier to manufacture, and the material properties can be more easily controlled during manufacturing.

[0052] FIGS. 2J and 2K illustrate alternative embodiments of leaf plates 144a and 144b, respectively that are similar to or the same as in many respects as the leaf plates 144 of FIGS. 2A-2J. However, the leaf plate 144a of FIG. 2J has wall portions 150a that are angled with respect to an upper portion 146a and lower edge portions 148a. The leaf plates 144b of FIG. 2K only have one of each of an upper portion 146b, a lower edge portion 148b, and a wall portion 150b.

[0053] FIGS. 3A-3D illustrate an alternative embodiment of a bow limb 216 that is similar to or the same as in many respects as the bow limbs 116 of FIGS. 2A-2I. For example, the bow limb 216 can have a proximal end 218 that is configured to be rigidly coupled with a stock (not shown), and a pulley (not shown) can be disposed at a distal end 222 of the bow limbs 216. However, the bow limb 216 can include an upper plate member 252, a lower plate member 254, with a cushioning member 256 sandwiched in between. Each of the upper and lower plate members 252, 254 can include respective mounting sleeves 258, 260 that facilitate mounting of the bow limb 216 to the stock (e.g., with pins). The upper and lower plate members 252, 254 can be formed of a metal or metal alloy such as high strength steel (HSS), Beryllium Copper, Phosphor Bronze, and/or Titanium, for example. In one embodiment, the upper and lower plate members 252, 254 can be formed of the same material while in another embodiment, the upper and lower plate members 252, 254 can be formed of different material. The cushioning member 256 can be formed of an elastomeric material, such as a vulcanized isoprene rubber (e.g., natural rubber), for example.

[0054] FIGS. 4A-4D illustrate an alternative embodiment of a bow limb 316 that is similar to or the same as in many respects as the bow limbs 16, 116 of FIGS. 1A-1E and 2A-2J, respectively. However, the bow limb 316 comprises an outer sheath 360 and an inner elongate rib member 362. As illustrated in FIGS. 4C and 4D, the outer sheath 360 and inner elongate RIB member 362 can deform as the bow limb 316 moves towards the loaded position. More particularly, the inner elongate rib member 362 can collapse into a substantially flat arrangement (i.e., buckle) which can result in *détente* (e.g., letdown) during pullback. The inner elongate rib member 362 can also control the buckling of the outer sheath 360 so as to provide a desirable pull characteristic during pullback. It is to be appreciated that examples of conventional

crossbow arrangements are provided in Appendix A. Appendix B illustrates various details (including some forces and moments) for different crossbow and/or bow limb arrangements.

[0055] FIG. 5 illustrates an alternative embodiment of a crossbow 410 that is similar to or the same as in many respects as the crossbow 110 of FIG. 2A. For example, the crossbow 410 includes a stock 412 and a pair of bow limbs 416 pivotally coupled with the stock 412. The bow limbs 416, however, are coupled together with a resilient member 464 that facilitates biasing of the bow limbs 416 into the relaxed position. For example, as the bow limbs 416 are drawn into the loaded position, proximal ends 418 are drawn away from each other (in the direction of arrow C) thereby stretching the resilient member 464 such that the resilient member 464 biases the bow limbs 416 into the relaxed position.

[0056] FIGS. 6-12 illustrate an alternative embodiment of a bow limb 516 that extends between a proximal end 518 and a distal end 522. The bow limb 516 includes an outer elongate member 552, an inner elongate member 554, and a core member 556 sandwiched between the outer elongate member 552 and the inner elongate member 554. In one embodiment, the outer and inner elongate members 552, 554 can be formed of hardened metal, and the core member 556 can be formed of a rubber. The core member 556 can be coupled with respective interior surfaces 566, 567 of the outer elongate member 552 and the inner elongate member 554 such that the outer elongate member 552 and the inner elongate member 554 are coupled together via the core member 556. The core member 556 can be coupled to the respective interior surfaces 566, 567 of the outer and inner elongate members 552, 554 with adhesive or any of a variety of other suitable attachment methods.

[0057] The outer elongate member 552 and the inner elongate member 554 can interface with each other at a seam 568. The outer and inner elongate members 552, 554 can be detached from each other along the seam 568 such that the outer elongate member 552 and the inner elongate member 554 are permitted to slide relative to each other when the bow limb 516 is bent (as will be described in further detail below with respect to FIGS. 24 and 26). Referring now to FIGS. 6-8 and 10, the outer and inner elongate members 552, 554 can cooperate to define a lateral opening 569 that is disposed between the proximal end 518 and the distal end 522 and through which the core member 556 is exposed. The lateral opening 569 allows for the outer and inner elongate members 552, 554 to compress together at the lateral opening 569 without interfering with each other when the bow limb 516 is bent (as will be described in further detail below with respect to FIGS. 24 and 26).

[0058] It is to be appreciated that the outer and inner elongate members 552, 554 can be formed of other metals, such as beryllium, copper, and/or titanium or any of a variety of other suitable materials that are stiffer than the material of the core member 556. It is also to be appreciated that the core member 556 can be formed of any of a variety of elastomeric materials and/or other suitable materials that are less stiff than the material of the outer and inner elongate members 552, 554.

[0059] Referring now to FIGS. 6, 7, 11 and 12, the outer elongate member 552 can be substantially c-shaped at each of the proximal end 518 and the distal end 522. In particular, the outer elongate member 552 can have a central member 570 and a pair of leg members 572 that extend from and cooperate with the central member 570 to define a c-shaped portion at each of the proximal and distal ends 518, 522. The inner elongate member 554 can be substantially c-shaped at the proximal end 518. In particular, the inner elongate member 554 can have a central

member 574 and a pair of leg members 576 that extend from and cooperate with the central member 574 to define a c-shaped portion at the proximal end 518. The core member 556 can be disposed within each of the c-shaped portions when attached to the outer and inner elongate members 552, 554. In one embodiment, the core member 556 can be coupled with the respective interior surfaces 566, 567 located at the central members 570, 574 of the respective outer and inner elongate members 552, 554. In such an embodiment, the core member 556 can be detached from the respective interior surfaces 566, 567 (e.g., devoid of adhesive) of the outer and inner elongate members 552, 554 at the respective leg members 572, 576. It is to be appreciated that any of a variety of configurations are contemplated for the outer elongate member and the inner elongate member. For example, in one alternative configuration, the inner elongate member and/or the outer elongate member might be a substantially flat steel member that is substantially devoid of any c-shaped portions (see, for example, FIGS. 3A-3C).

[0060] Referring now to FIGS. 6-8 and 10, the distal end 522 of the bow limb 516 can define a through hole 577 that facilitates rotatable coupling of a cam (e.g., 514 in FIG. 13) to the distal end 522 of the bow limb 516. The through hole 577 can extend through each of the leg members 572 of the outer elongate member 552 and through the core member 556.

[0061] Referring now to FIG. 13, a portion of a right side of a crossbow is shown that incorporates a pair of the bow limbs 516 illustrated in FIGS. 6-12. The proximal ends 518 of each of the bow limbs 516 can be coupled to a front end 513 of the crossbow with a clamp 578. A cam 514 can be rotatably coupled to the distal ends 522 of the pair of bow limbs 516 (e.g., via the through holes 577) and a bow string 520 can be routed around the cam 514 which can facilitate firing of a bolt (e.g., an arrow) from the crossbow. It is to be appreciated that another pair of the bow limbs 516 can be incorporated into a left side of the crossbow that is effectively a

mirror image of what is shown in FIG. 13 and that cooperates with the bow limbs 516 on the right side to facilitate firing of a bolt from the crossbow.

[0062] The bow limbs 516 can be arranged on the crossbow such that the outer elongate members 552 of one pair of bow limbs 516 faces away from the outer elongate members 552 of the other pair of bow limbs 516, and the inner elongate members 554 of one pair of bow limbs 516 faces the inner elongate members 554 of the other pair of bow limbs 516. When a bolt is loaded into the crossbow and pulled rearwardly (e.g., in the direction of arrow P in FIG 1A), the bow limbs 516 can be bent into a loaded position. Bending of the bow limbs 516 into the loaded position can cause the outer elongate members 552 of each bow limbs 516 to slide with respect to each other, thus causing the core member 556 to become deformed (see for example FIGS. 21-24). The stiffness of the outer and inner elongate members 552, 554 cooperates with the deformation of the core member 556 to effectively resist the bending of the bow limbs 516 into the loaded position. As a result, when the crossbow is fired, the bow limbs 516 can straighten out, thus releasing the tension in bow limbs 516 to fire the bolt from the crossbow 510.

[0063] The bow limbs 516 can perform as well or better than conventional fiber reinforced plastic (FRP) bow limbs and can thus serve as a cost effective replacement for those conventional bow limbs (e.g., during manufacturing of a crossbow or as a retrofit for an existing cross bow). For example, the materials used to manufacture the outer and inner elongate members 552, 554 and the core member 556 (e.g., steel and rubber, respectively) is typically more readily available and less expensive than FRP. In addition, the manufacturing process for those materials is less complicated than FRP, and in some cases, can be simple enough for a cross bow manufacturer to perform rather than relying on a third party bow limb manufacturer, as is typically the case with manufacturing bow limbs out of FRP. The materials and

manufacturing process of the bow limbs 516 can yield more predictable results. For example, the characteristics of the materials that might affect the performance of the bow limbs (e.g., thickness, stiffness, imperfections) are more easily controlled than FRP. In addition, the overall structure of the bow limbs is such that the performance of the bow limbs is less susceptible to being affected by slight variability in the material characteristics. This consistency among the bow limbs can alleviate the need to test each bow limb and match it with a similar performing bow limb (e.g., sorting), as is typical with FRP bow limbs, which can be time consuming and inefficient.

[0064] The testing methodology for arriving at the overall design of the bow limb 516 illustrated in FIGS. 6-13 will now be discussed. First, a conventional FRP bow limb was repeatedly tested during use in a crossbow to understand the various performance metrics (e.g., stress, strain, deflection, etc.) that the FRP bow limb was subjected to during use. Analyzing the data from this testing revealed that a significant amount of stress and strain occurred at the outside layer of the conventional FRP bow limb during bending. Using that data, a sandwiched arrangement having outer and inner metal layers spaced apart by a pliable core and slidable relative to each other was selected as a possible alternative arrangement (one example of such an arrangement is illustrated in FIGS. 3A-3D). Various materials were then explored for the outer and inner metal layers and the pliable core to determine whether there was a suitable composition for each component that would yield a low cost, predictable, easy to manufacture bow limb as an alternative to the conventional FRP bow limb. Through testing and/or modeling, certain metals, such as high strength steel, beryllium copper, and titanium, for example, were determined to be suitable for the outer and inner metal layers, and an elastomeric material, such as a rubber having a modulus of between about 1 kilopound per square inch (KSI) and about 10

KSI, was determined to be suitable for the elastomeric material. It is to be appreciated however, that other suitable metals and elastomeric materials were contemplated and found to be suitable.

[0065] Once the general design and materials were selected, the particular configuration of the outer and inner metal layers (e.g., shape, thickness, and length) as well as the configuration of the elastomeric material could then be designed (e.g., engineered) to achieve a desired stiffness (e.g., weight divided by distance) for the bow limb 516. As such, bow limbs (e.g., 516) with different stiffnesses can be provided to accommodate the various skill levels of users.

[0066] Referring now to FIG. 14, a plot is illustrated that depicts one example of the relationship between a load provided to the distal ends 522 of the bow limb 516 (in pounds of force) and the resulting deflection of the bow limb 516 (in inches) for various modulus values of the core member 556 as compared to a conventional FRP bow limb. The response of the conventional FRP bow limb is shown in dashed lines. The response of the bow limb 516 is shown by the other plots on the graph. The plot can be understood to illustrate how the modulus of the core member 556 can be selected to match the response of the conventional FRP bow limb as well as how different modulus values affect the response of the bow limb 516 without changing the outer and inner elongate members 552, 554. The plot can be also be understood to illustrate how different modulus values can be selected for the core member 556 of the bow limb 516 to provide a different response (e.g., for users of different skill levels).

[0067] For example, a core member 556 having a modulus of about 10 KSI can have a response (identified as Plot A) that closely resembles the response of the conventional FRP bow limb. However, as the modulus of the core member 556 is decreased, the relationship between

the load provided to the distal ends 522 of the bow limb 516 and the resulting deflection of the bow limb 516 decreases. When the bow limb 516 is provided with a modulus value of about 4 KSI, the response of the bow limb 516 to load (identified as Plot B) is still substantially constant (e.g., the slope of the plot is substantially straight), however, the bow limb 516 does not deflect as much under the same load as the bow limb 516 having a core member 556 with a modulus value of about 10 KSI. When the bow limb 516 is provided with a modulus value of about 2.5 KSI, the response of the bow limb 516 (identified as Plot C) to load is still substantially constant (e.g., the slope of the plot is substantially straight), however, the bow limb 516 does not deflect as much under the same load as the bow limb 516 having a core member 556 with a modulus value of about 4 KSI. When the bow limb 516 is provided with a modulus value of about 1 KSI, the response of the bow limb 516 (identified as Plot D) to load is still substantially constant (e.g., the slope of the plot is substantially straight), however, the bow limb 516 does not deflect as much under the same load as the bow limb 516 having a core member 556 with a modulus value of about 2.5 KSI.

[0068] It is to be appreciated that the plot illustrated in FIG. 14 can also be understood to illustrate how manufacturing tolerances in the modulus of the core member 556 (e.g., material characteristics) do not significantly adversely affect the performance of the bow limb 516. For example, the modulus of the core member 556 might vary slightly (along the length of the core member 556) due to manufacturing tolerances. However, these variations in the modulus are typically within the range of between about 0.1 and about 10 PSI and thus not significant enough (relative to plots B-D) to adversely affect the overall performance of the bow limb 516.

[0069] FIGS. 15-22 illustrate an alternative embodiment of a bow limb 616 that is similar to or the same in many respects as the bow limb 316 illustrated in FIGS. 6-13. For example, the

bow limb 616 can extend between a proximal end 618 and a distal end 622 and can include an outer elongate member 652, an inner elongate member 654, and a core member 656 that is sandwiched between the outer and inner elongate members 652, 654. As illustrated in FIGS. 16 and 17, the core member 656 can be coupled with respective interior surfaces 666, 667 located at central members 670, 674 of the respective outer and inner elongate members 652, 654. In such an embodiment, the core member 656 can be detached from the respective interior surfaces 666, 667 (e.g., devoid of adhesive) of the outer and inner elongate members 652, 654 at respective leg members 672, 676.

[0070] Referring now to FIG. 18, the outer elongate member 652 is shown to include a proximal end portion 680, a distal end portion 681, and a central portion 682 disposed between the proximal and distal end portions 680, 681. The outer elongate member 652 can have a length L1. The proximal end portion 680 can have a length L2, the distal end portion 681 can have a length L3, and the central portion 682 can have a thickness T1. In one embodiment, the length L1 can be about 11 inches, the length L2 can be about 1.5 inches, the length L3 can be about 1.5 inches, and the thickness T1 can be about 0.062 inches.

[0071] The outer elongate member 652 is shown to include a proximal transition portion 683 and a distal transition portion 684. The proximal transition portion 683 can extend between the proximal end portion 680 and the central portion 682 and is shown to have a radius of curvature R1. The distal transition portion 684 can extend between the distal end portion 681 and the central portion 682 and is shown to have a radius of curvature R2. In one embodiment, the radii of curvature R1 and R2 can be about 3 inches. It is to be appreciated that the area between the proximal end portion 680 and the distal end portion 681 can at least partially define a lateral opening (e.g., 369) for the bow limb 616.

[0072] Referring now to FIG. 19, the distal end portion 682 is shown to have a central member 670a and a pair of leg members 672a that extend therefrom. The central member 670a can have a length L4, the leg members 672a can have a height H1 a thickness T2. In one embodiment, the length L4 can be about 0.531 inches, the height H1 can be about 0.5 inches and the thickness T2 can be about 0.062 inches. Referring now to FIG. 20, the proximal end portion 680 is shown to have a central member 670b and a pair of leg members 672b that extend therefrom. The central member 670b can have a length L5, the leg members 672b can have a height H2 a thickness T3. In one embodiment, the length L5 can be about 0.531 inches, the height H2 can be about 0.219 inches and the thickness T3 can be about 0.062 inches.

[0073] Referring now to FIG. 21, the inner elongate member 654 is shown to include a proximal end portion 685 and a distal end portion 686. The inner elongate member 654 can have a length L6. The proximal end portion 685 can have a length L7 and the distal end portion 686 can have a thickness T4. In one embodiment, the length L6 can be about 11 inches, the length L7 can be about 1.5 inches, and the thickness T4 can be about 0.062 inches. The inner elongate member 654 is shown to include a proximal transition portion 687 that extends between the proximal end portion 685 and the distal end portion 686. The proximal transition portion 687 is shown to have a radius of curvature R3. In one embodiment, the radius of curvature R3 can be about 3 inches.

[0074] Referring now to FIG. 22, the proximal end portion 685 is shown to have a central member 672 and a pair of leg members 676 that extend therefrom. The central member 672 can have a length L8, the leg members 676 can have a height H3 and a thickness T5. In one embodiment, the length L8 can be about 0.531 inches, the height H3 can be about 0.219 inches and the thickness T5 can be about 0.062 inches. It is to be appreciated that the dimensions of

the bow limb 616 described above should be understood to be one example of many different dimensions that are contemplated.

[0075] FIGS. 23 and 24 illustrate another alternative embodiment of a bow limb 716 that is similar to or the same in many respects as the bow limb 316 illustrated in FIGS. 6-13. For example, the bow limb 716 can extend between a distal end 718 and a proximal end 722 and can include an outer elongate member 752, an inner elongate member 754, and a core member 756 that is sandwiched between the outer and inner elongate members 752, 754. As illustrated in FIG. 24, when the bow limb 716 is bent from an unloaded position (shown in solid lines) to a loaded position (shown in dashed lines), the outer and inner elongate members 752, 754 can compress together at a lateral opening 769, and the inner elongate member 754 can slide laterally with respect to the outer elongate member 752 such that a portion of the inner elongate member 754 can extend beyond the outer elongate member 752. The core member 756 can become deformed where the inner elongate member 754 extends beyond the outer elongate member 752 which can allow for such sliding of the inner elongate member 754 relative to the outer elongate member 752.

[0076] FIGS. 25 and 26 illustrate yet another alternative embodiment of a bow limb 816 that is similar to or the same in many respects as the bow limb 716 illustrated in FIGS. 23 and 24. For example, the bow limb 816 can extend between a distal end 818 and a proximal end 822 and can include an outer elongate member 852, an inner elongate member 854, and a core member 856 that is sandwiched between the outer and inner elongate members 852, 854.

[0077] Referring now to FIG. 27, a plot is illustrated that depicts one example of the relationship between a tip force (e.g., load) provided to the distal ends 722, 822 of the respective

bow limbs 716, 816 (in pounds of force) and the resulting tip deflection of the bow limbs 716, 816 (in inches) illustrated in FIGS. 23-26.

[0078] FIG. 28 illustrates yet another alternative embodiment of a bow limb 916 that is similar to or the same in many respects as the bow limb 316 illustrated in FIGS. 6-13. For example, the bow limb 916 can extend between a distal end 918 and a proximal end 922 and can include an outer elongate member 952, an inner elongate member 954, and a core member 956 that is sandwiched between the outer and inner elongate members 952, 954.

[0079] FIG. 29 illustrates still yet another alternative embodiment of a bow limb 1016 that is similar to or the same in many respects as the bow limb 316 illustrated in FIGS. 6-13. For example, the bow limb 1016 can extend between a proximal end 1018 and a distal end 1022 and can include an outer elongate member 1052, an inner elongate member 1054, and a core member 1056 that is sandwiched between the outer and inner elongate members 1052, 1054. However, the outer elongate member 1052 and the inner elongate member 1054 can be formed together as a one piece construction that defines a seam 1068.

[0080] FIG. 30 illustrates still yet another alternative embodiment of a pair of bow limbs 1116 that are each similar to or the same in many respects as the bow limb 316 illustrated in FIGS. 6-13. For example, each bow limb 1116 can include a proximal end 1118. However, the proximal end 1118 can have a flared profile (e.g., a width that increases as it approaches the proximal end 1118) that can alleviate the possibility of the bow limbs 1116 being pulled away from the clamp 1178 when the bow limbs 1116 are bent into a firing position.

[0081] FIG. 31 illustrates still yet another alternative embodiment of a pair of bow limbs 1216 that are each similar to or the same in many respects as the bow limb 316 illustrated in

FIGS. 6-13. For example, each bow limb 1216 can include a proximal end 1218, a distal end 1222, and a core member 1256. However, each bow limb 1216 can include a hinge member 1288 that can facilitate pivoting of the distal end 1222 relative to the proximal end 1218. Each core member 1256 can also include an embedded spring 1290 that facilitates biasing of the associated bow limb 1216 into a straightened position. When the bow limbs 1216 are in a straightened position, each embedded spring 1290 can be in a relaxed state (see FIG. 32). When the bow limbs 1216 are bent (e.g., in a firing position), each embedded spring 1290 can be in a bent state (see FIG. 33) which can facilitate biasing of the associated bow limb 1216 into the straightened position.

[0082] The foregoing description of embodiments and examples of the disclosure has been presented for purposes of illustration and description. It is not intended to be exhaustive or to limit the disclosure to the forms described. Numerous modifications are possible in light of the above teachings. Some of those modifications have been discussed and others will be understood by those skilled in the art. The embodiments were chosen and described in order to best illustrate the principles of the disclosure and various embodiments as are suited to the particular use contemplated. The scope of the disclosure is, of course, not limited to the examples or embodiments set forth herein, but can be employed in any number of applications and equivalent devices by those of ordinary skill in the art. Rather it is hereby intended the scope of the invention be defined by the claims appended hereto.

WHAT IS CLAIMED IS:

1. A limb for an archery bow, the limb comprising:

an outer elongate member formed of a first material and comprising an interior surface and an exterior surface;

an inner elongate member formed of a second material and comprising an interior surface and an exterior surface; and

a core member formed of a third material and sandwiched between the outer elongate member and the inner elongate member, the core member being coupled with at least a portion of each of the interior surfaces of the outer elongate member and the inner elongate member; wherein:

the outer elongate member and the inner elongate member are configured to move relative to each other when the limb is bent; and

the first material and the second material are each stiffer than the third material;

the first material and the second material comprise one or more of high strength steel, beryllium copper, and titanium; and

the third material comprises an elastomeric material.

2. An archery bow comprising the limb of claim 1.

3. A limb for an archery bow, the limb comprising:

an outer elongate member formed of a first material and comprising an interior surface and an exterior surface;

an inner elongate member formed of a second material and comprising an interior surface and an exterior surface; and

a core member formed of a third material and sandwiched between the outer elongate member and the inner elongate member, the core member being coupled with at least a portion of each of the interior surfaces of the outer elongate member and the inner elongate member; wherein:

the outer elongate member and the inner elongate member are configured to move relative to each other when the limb is bent;

the first material and the second material are each stiffer than the third material; and

the outer elongate member and the inner elongate member each comprise a central member and a pair of leg members that extend from and cooperate with the central member to define a c-shaped portion.

4. The limb of claim 3 wherein:

the core member is coupled with the interior surface located at the central member of each of the outer elongate member and the inner elongate member; and

the core member is decoupled from the interior surface located at each leg member of the pair of leg members of each of the outer elongate member and the inner elongate member.

5. An archery bow comprising the limb of claim 3 or 4.

6. A limb for an archery bow, the limb comprising:

an outer elongate member formed of a first material and comprising a central member and a pair of leg members that extend from the central member;

an inner elongate member formed of a second material and comprising a central member and a pair of leg members that extend from the central member; and

a core member formed of a third material and sandwiched between the outer elongate member and the inner elongate member; wherein:

the core member is coupled with the central member of the outer elongate member and the central member of the inner elongate member;

the core member is decoupled from the pair of leg members of the outer elongate member and the pair of leg members of the inner elongate member;

the outer elongate member and the inner elongate member are configured to move relative to each other when the limb is bent; and

the first material and the second material are each stiffer than the third material.

7. The limb of claim 6, wherein:

the first material and the second material comprise one or more of high strength steel, beryllium copper, and titanium; and

the third material comprises an elastomeric material.

8. The limb of claim 6, wherein at least one leg member of the pair of leg members of the inner elongate member and at least one leg member of the pair of leg members of the outer elongate member interface with each other along a seam.

9. The limb of claim 8, wherein the outer elongate member and the inner elongate member are detached from each other along the seam such that the outer elongate member and the inner elongate member are slidable relative to each other when the limb is bent.

10. An archery bow comprising the limb of any one of claims 6 to 9.

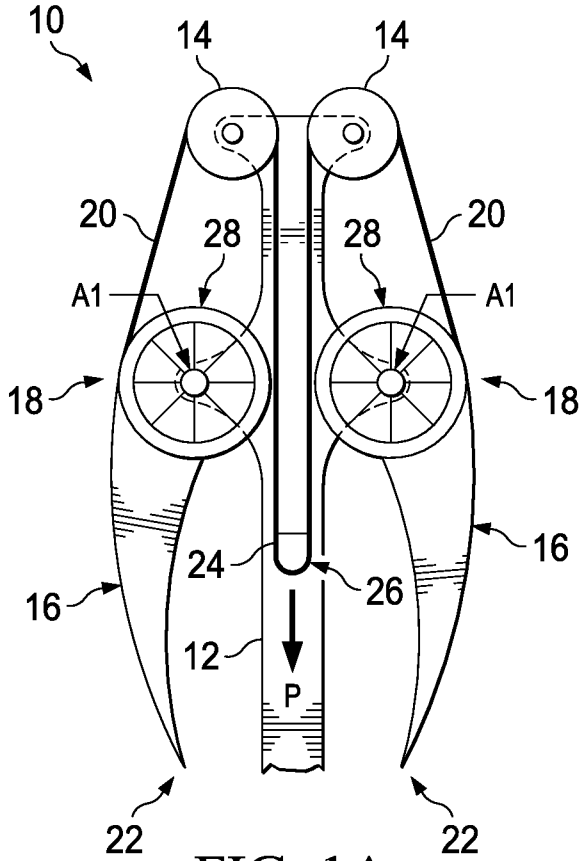

FIG. 1A

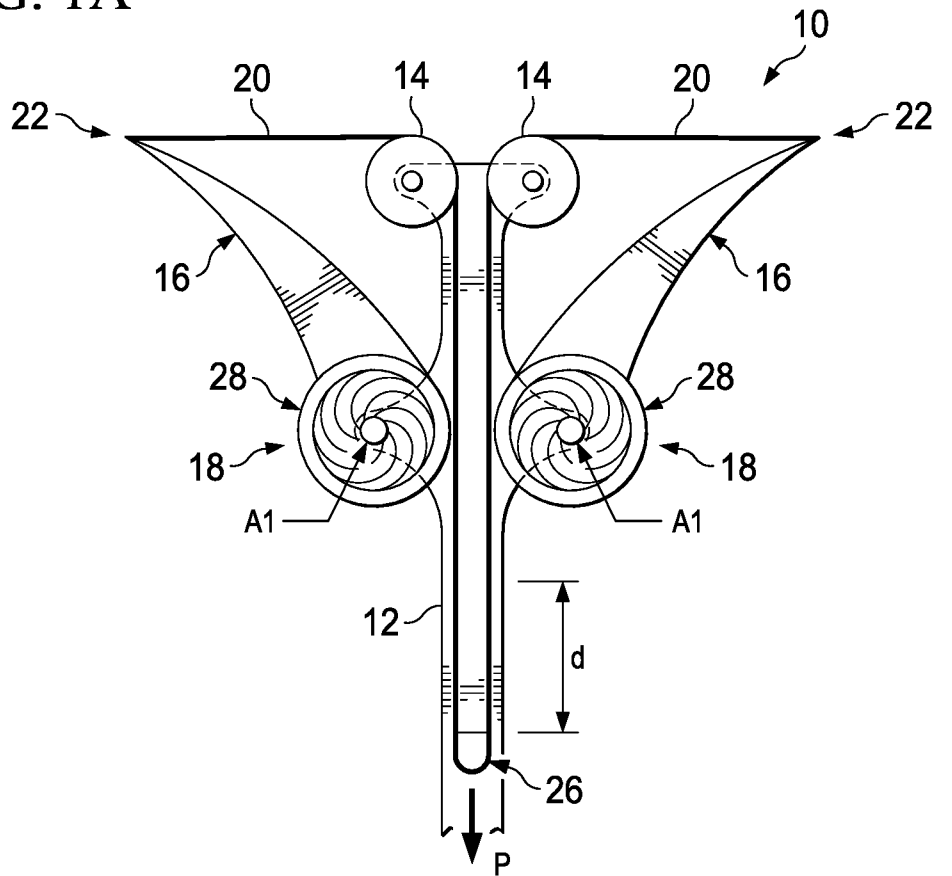

FIG. 1B

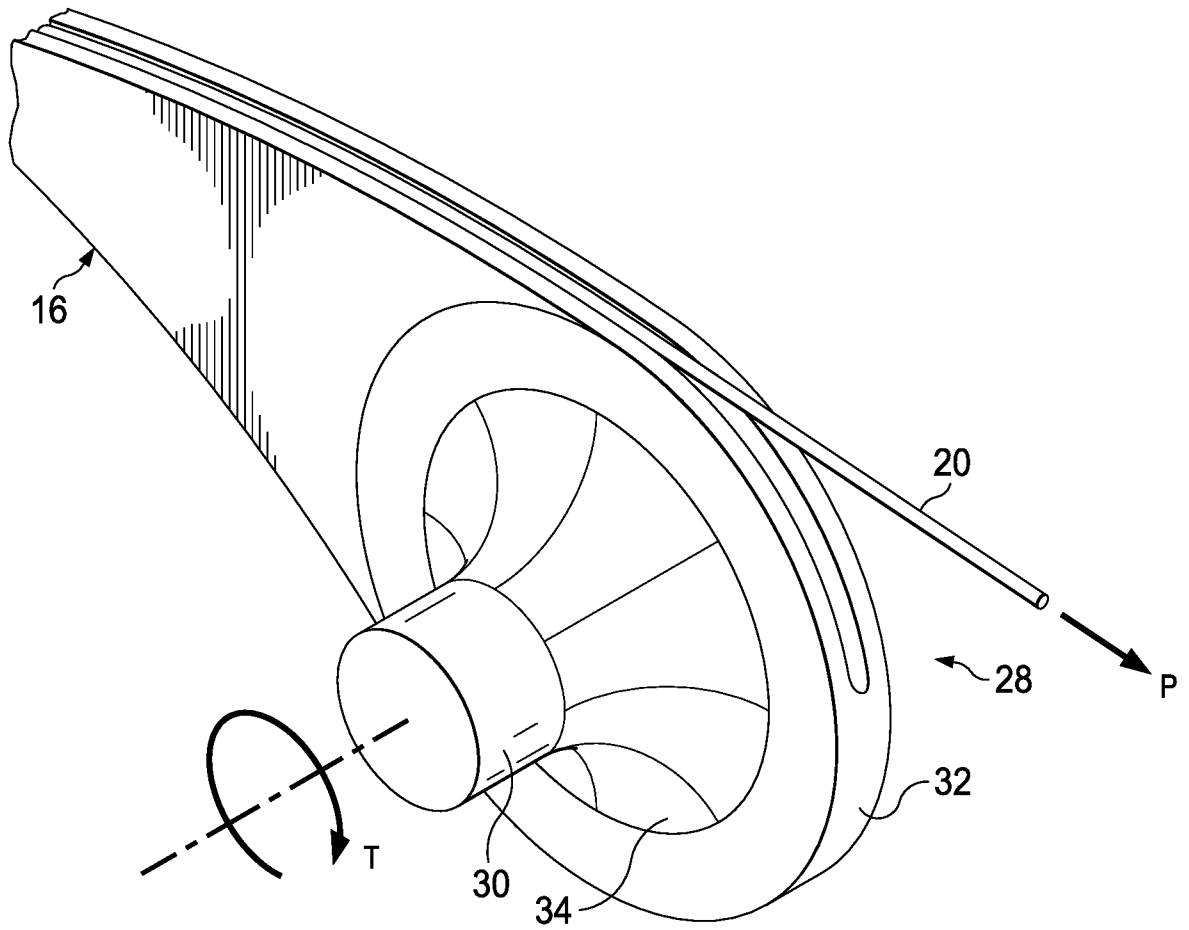

FIG. 1C

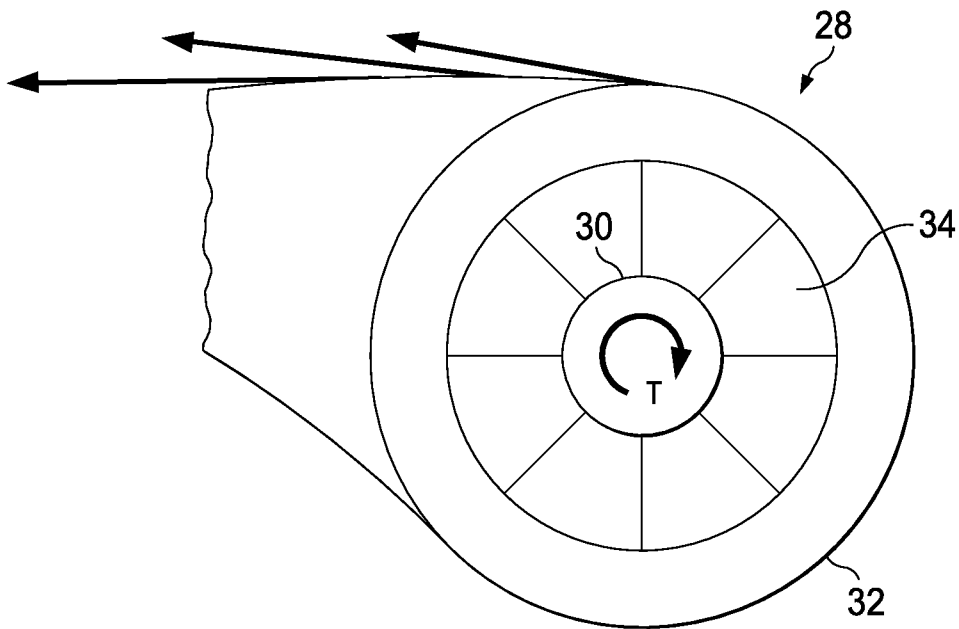

FIG. 1D

FIG. 1E

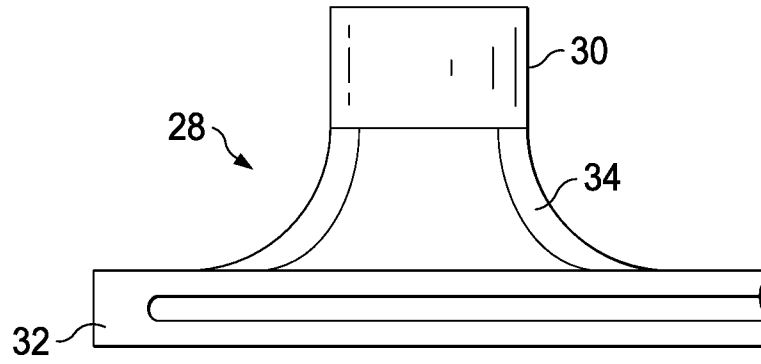
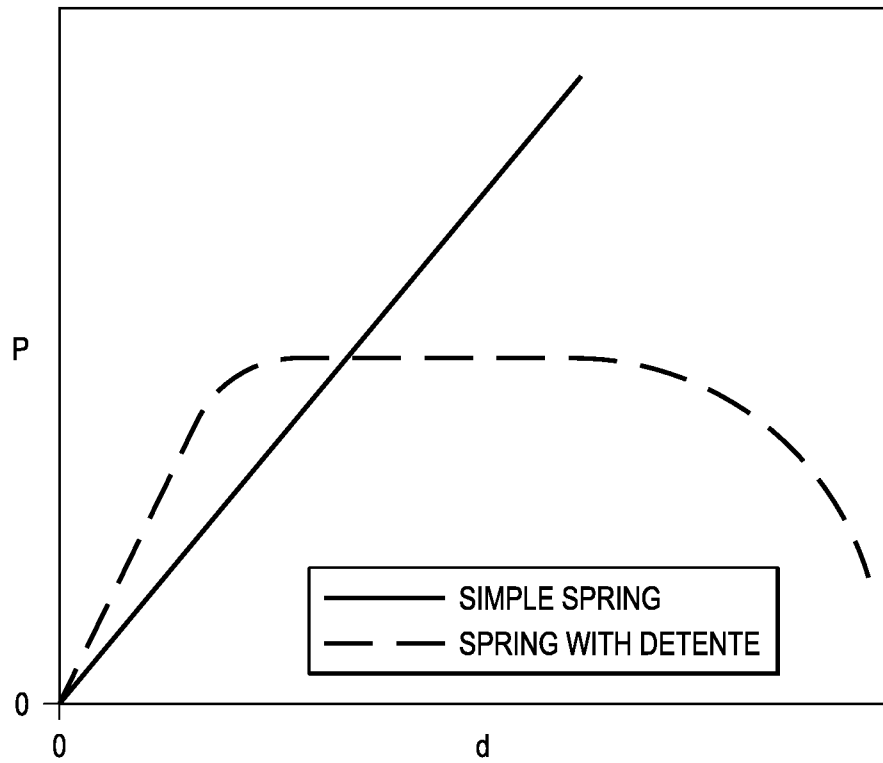

FIG. 1F



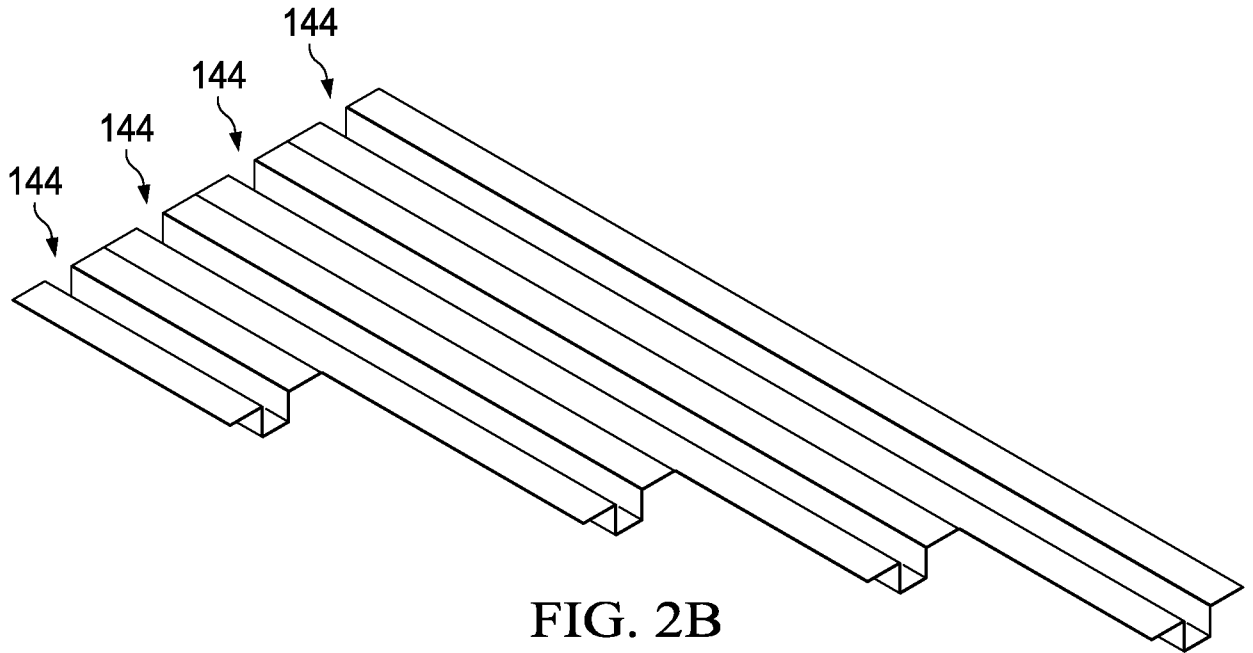

FIG. 2B

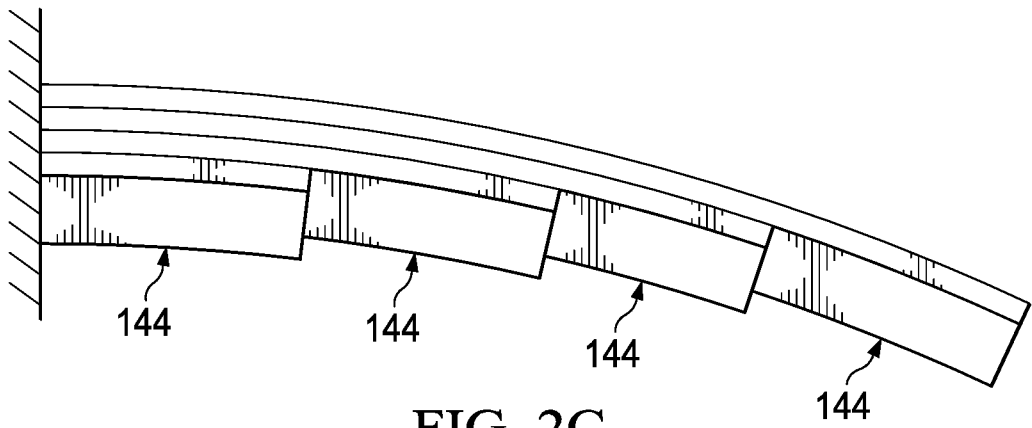

FIG. 2C

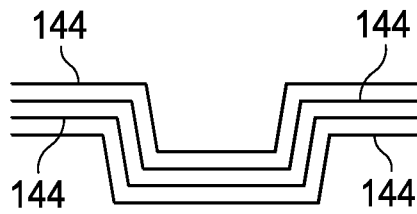
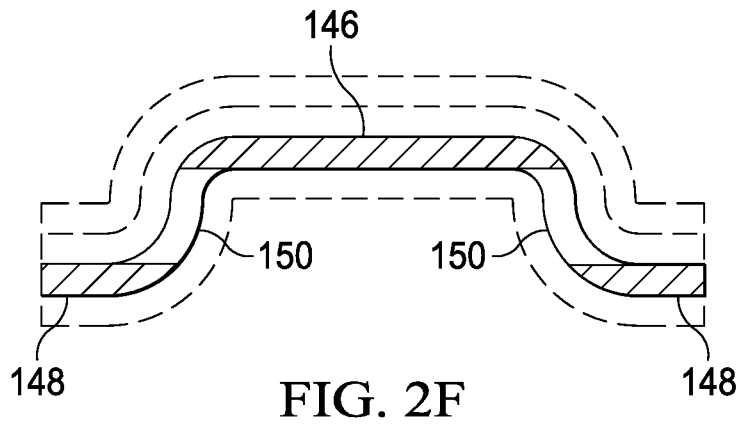
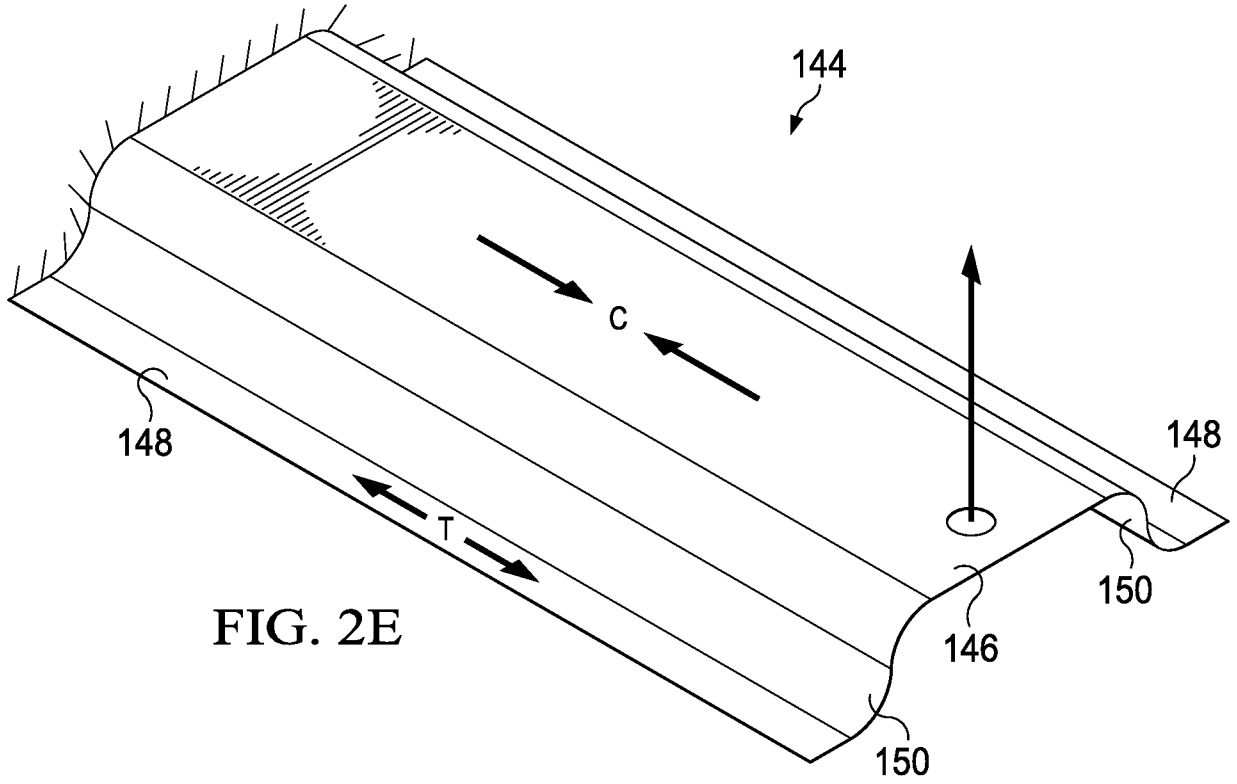

FIG. 2D



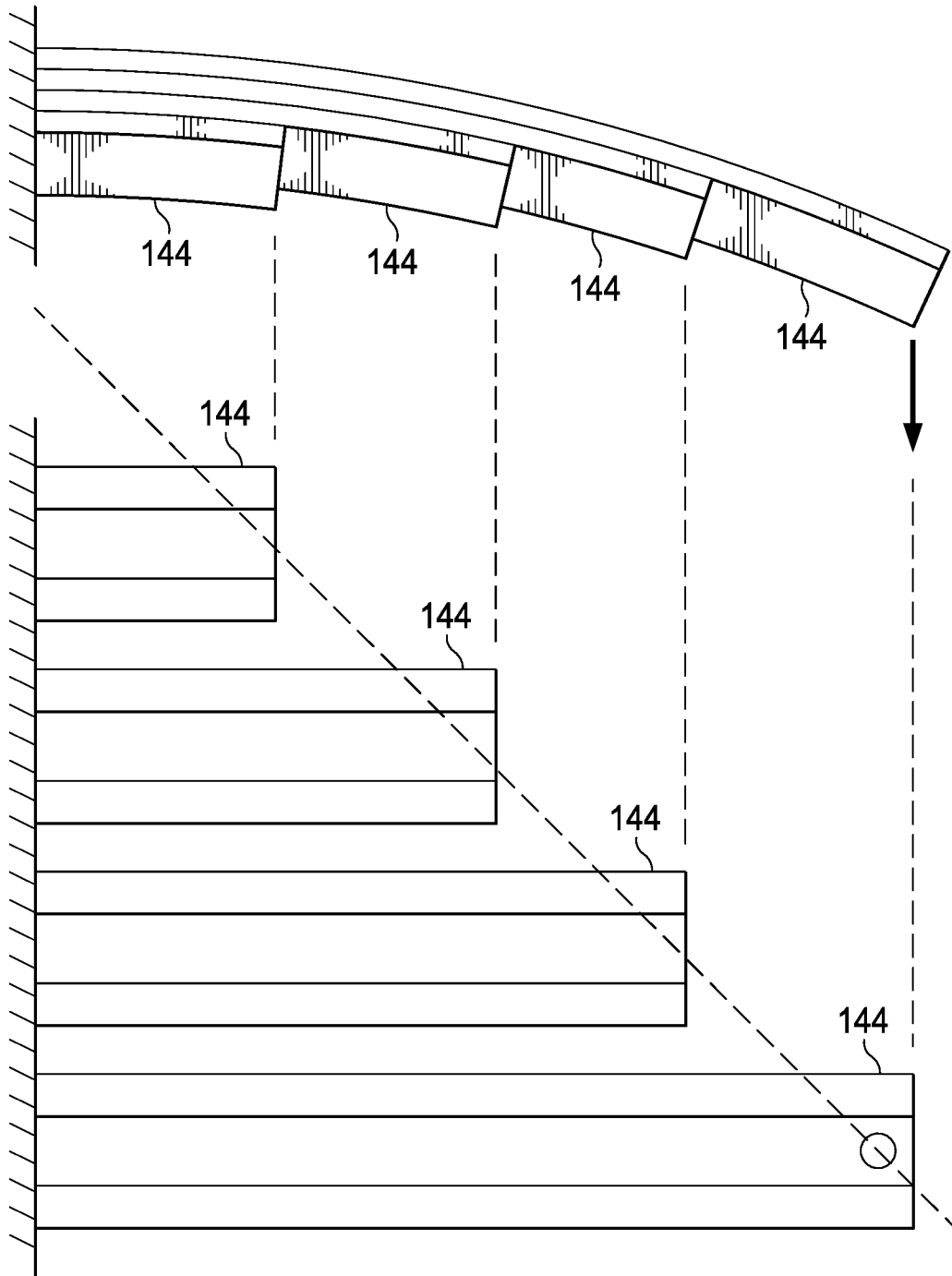

FIG. 2G

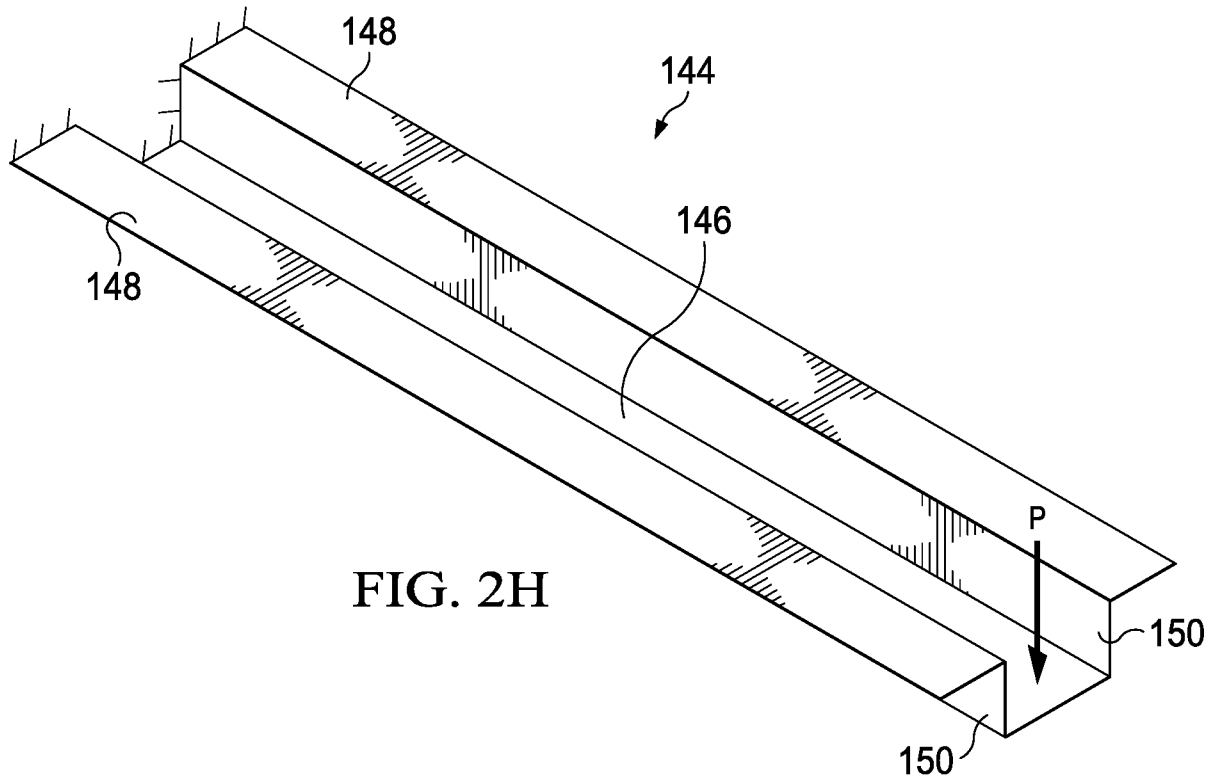

FIG. 2H

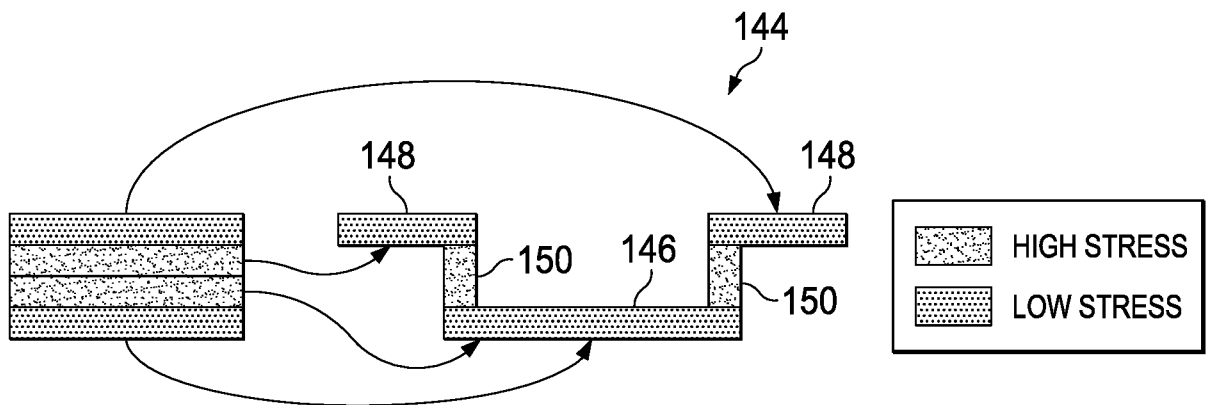

FIG. 2I

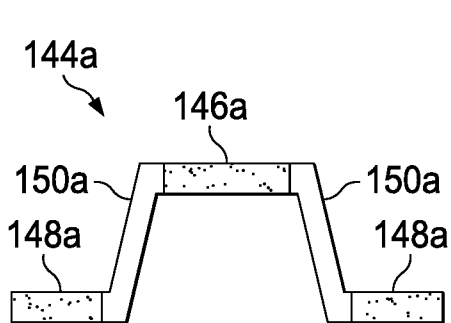

FIG. 2J

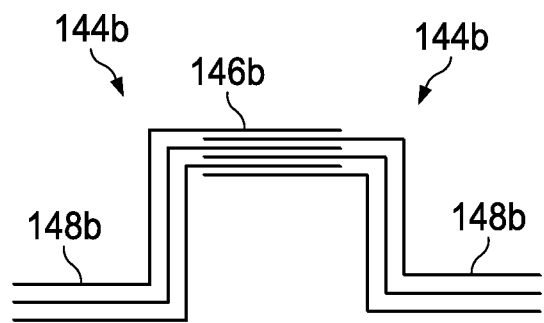
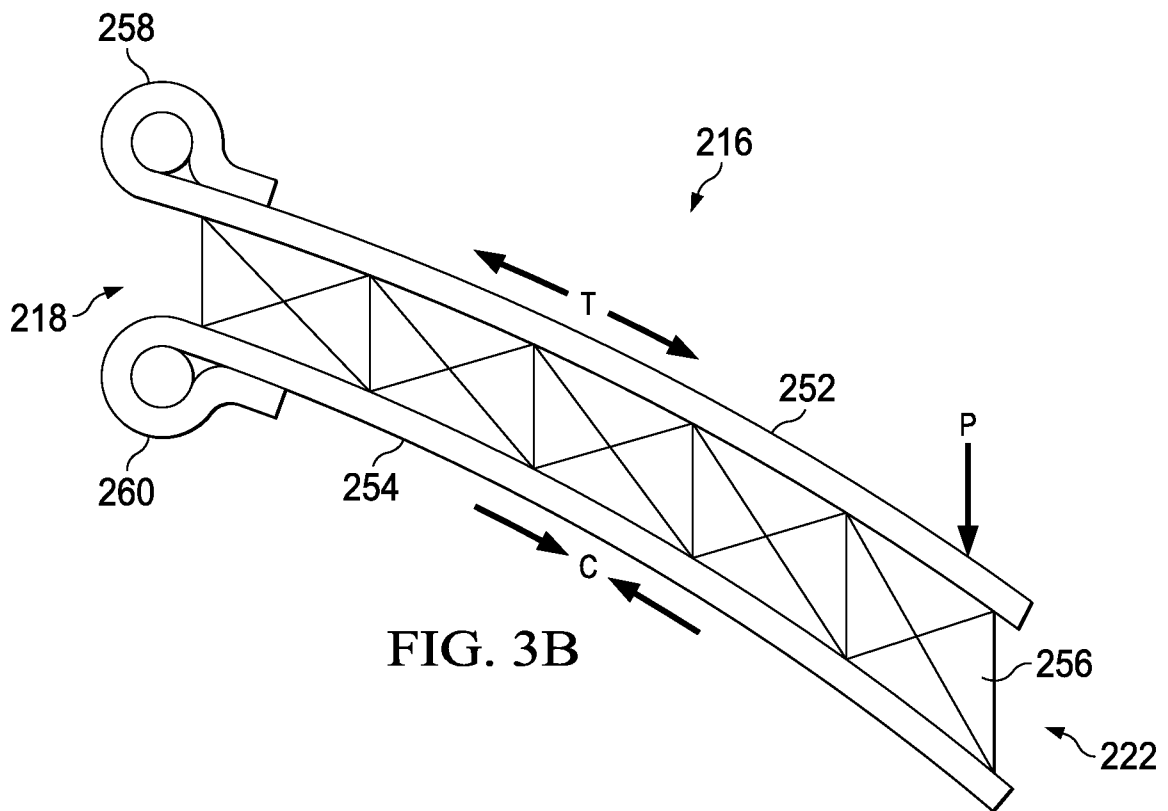
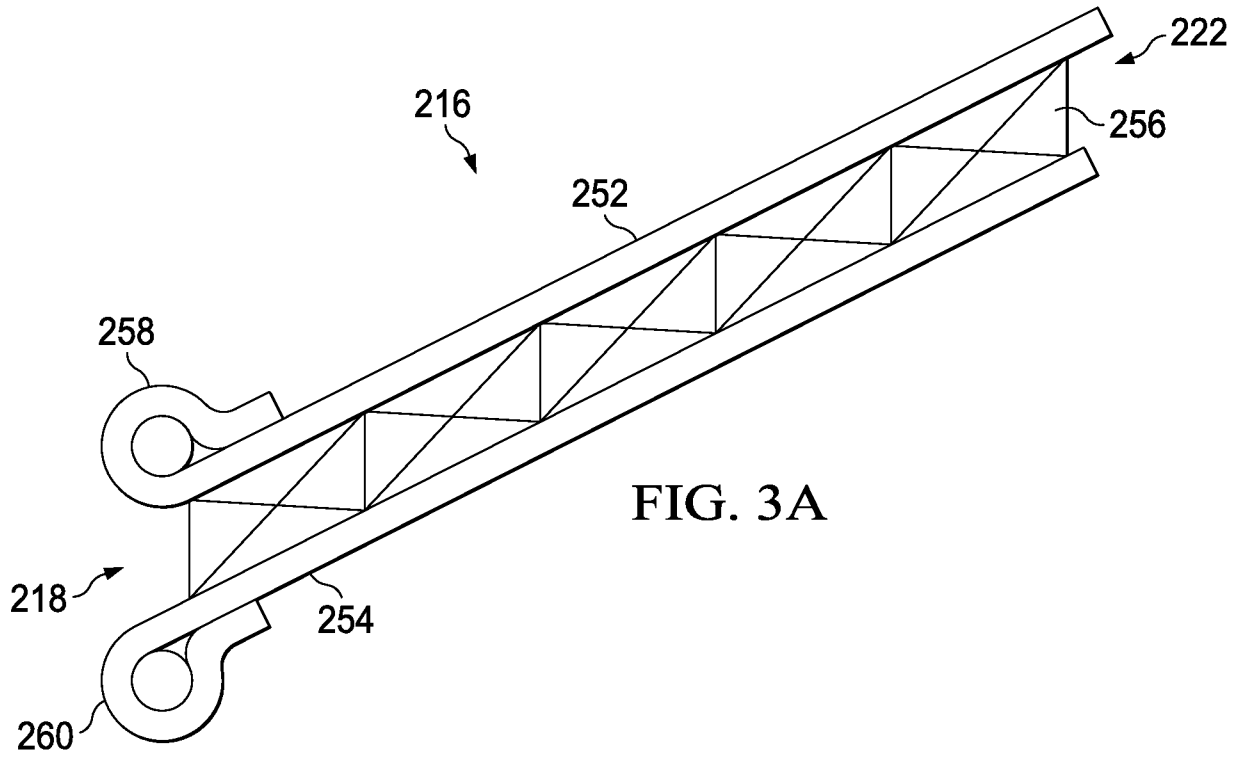
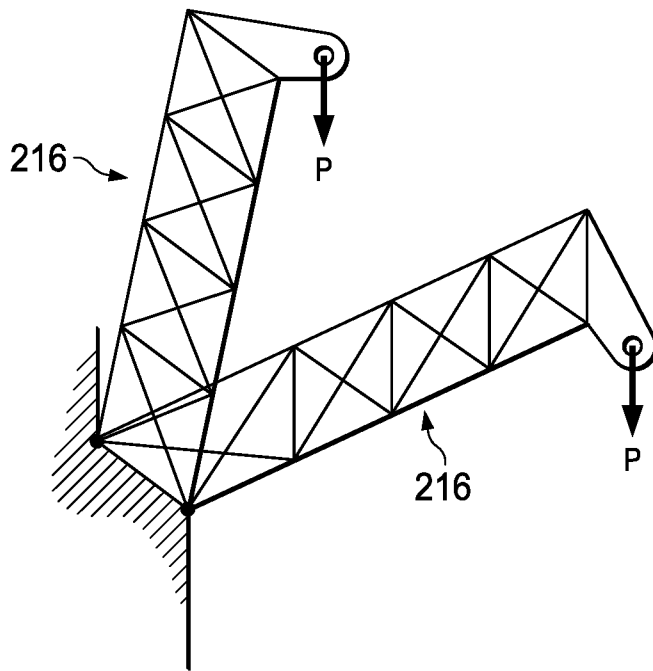
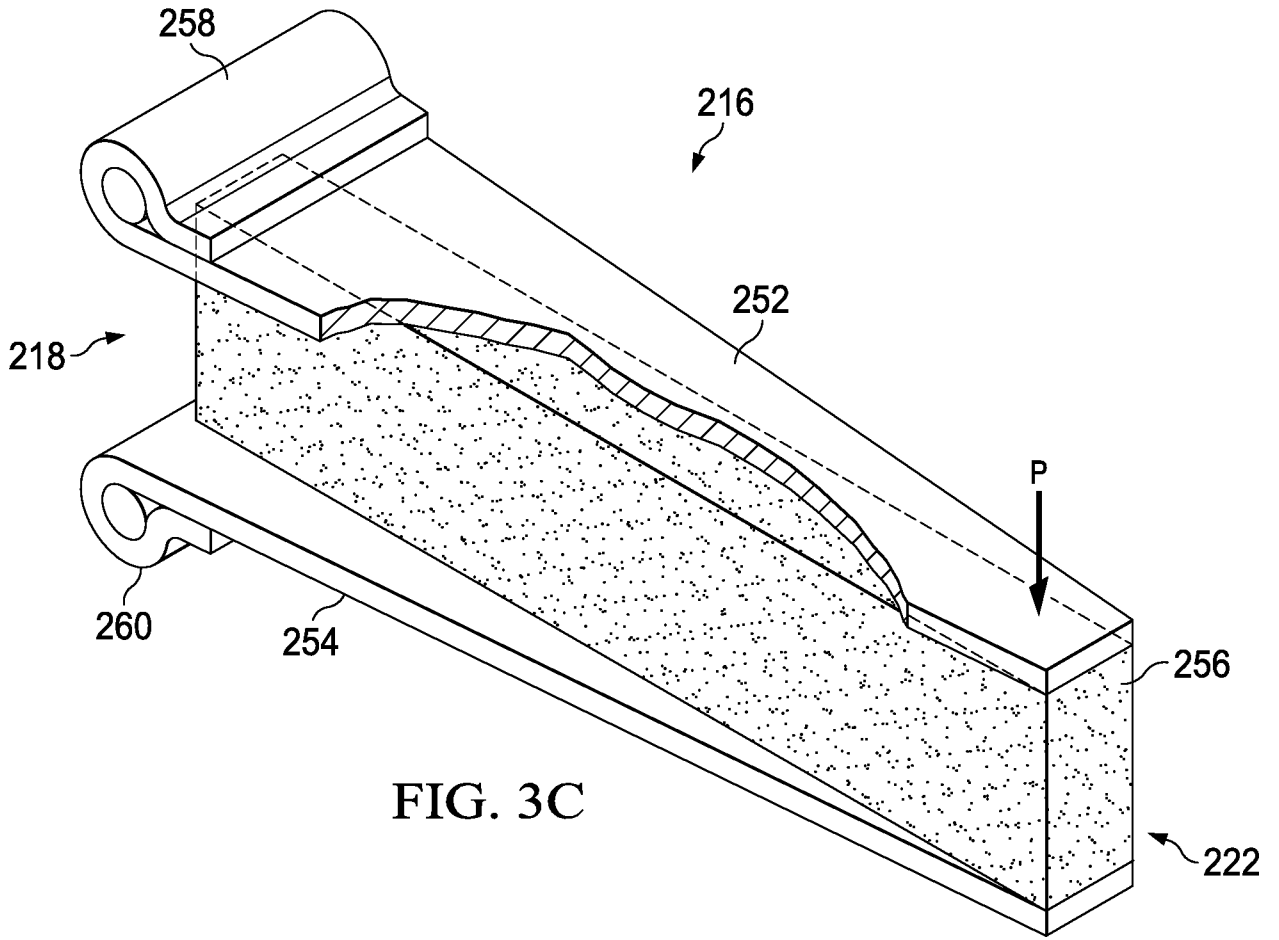

FIG. 2K





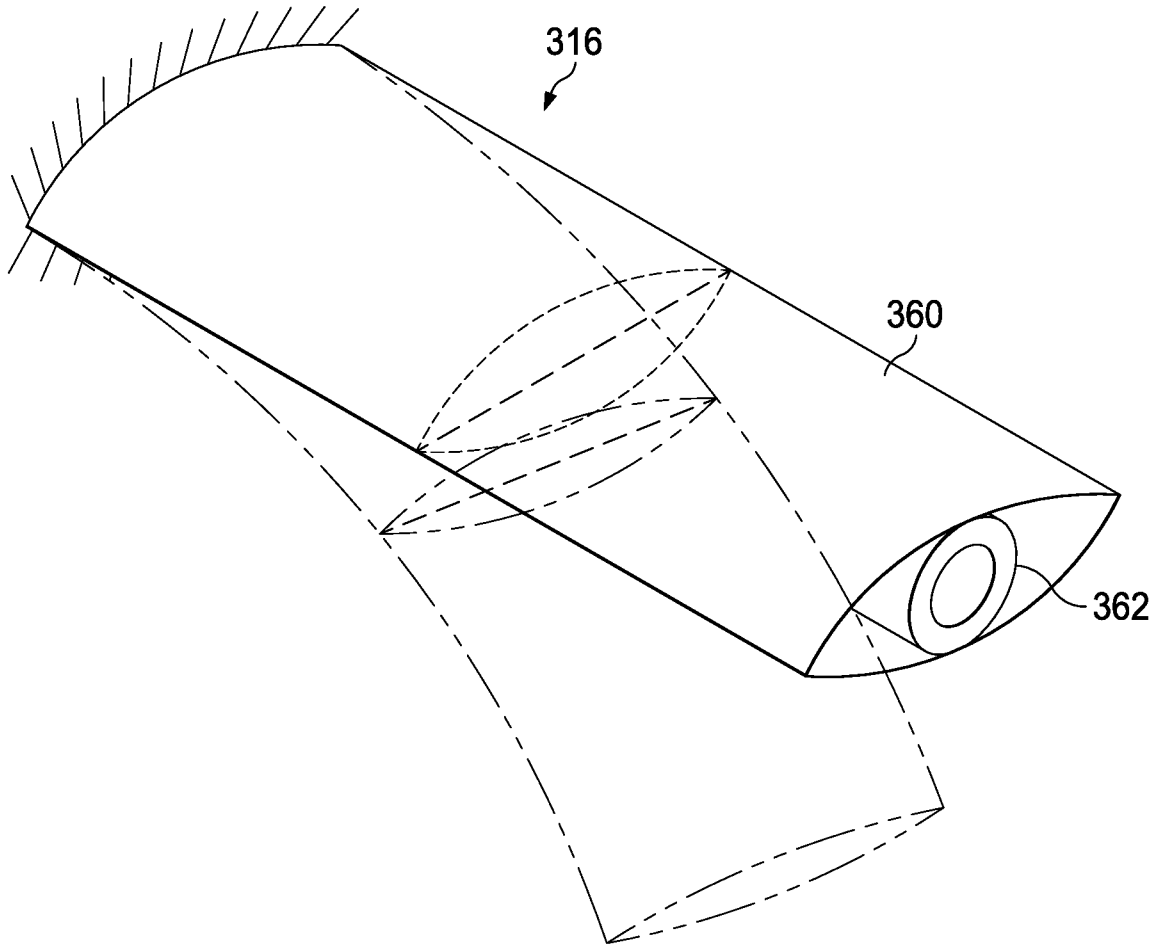

FIG. 4A

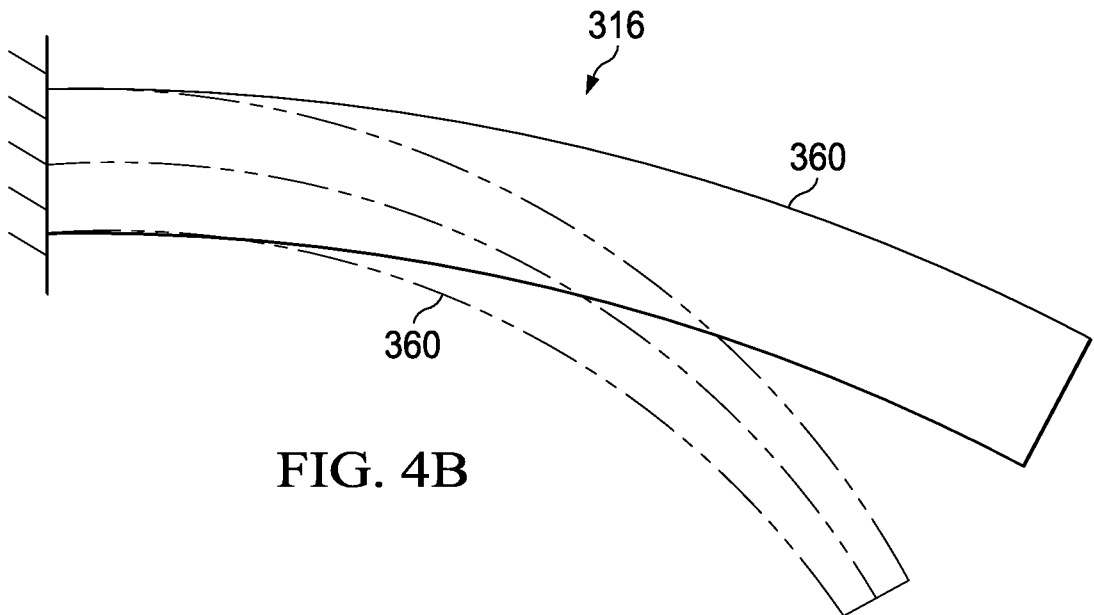

FIG. 4B

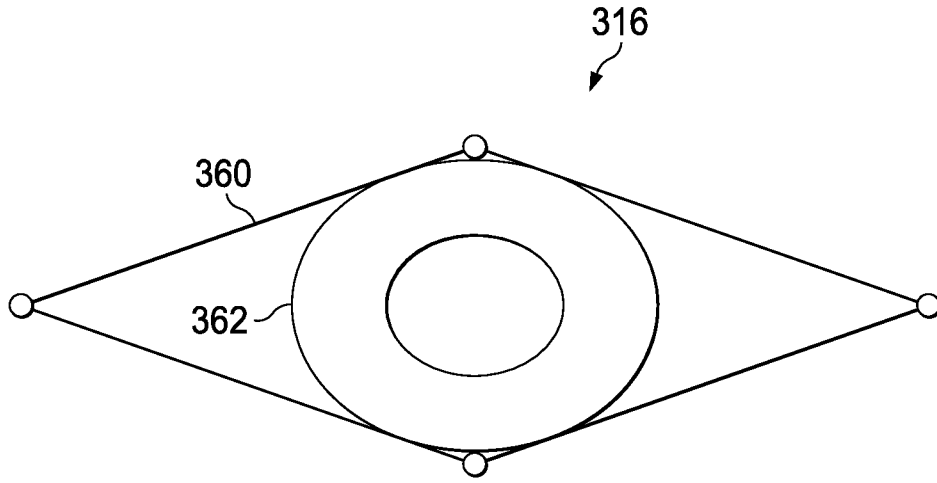

FIG. 4C

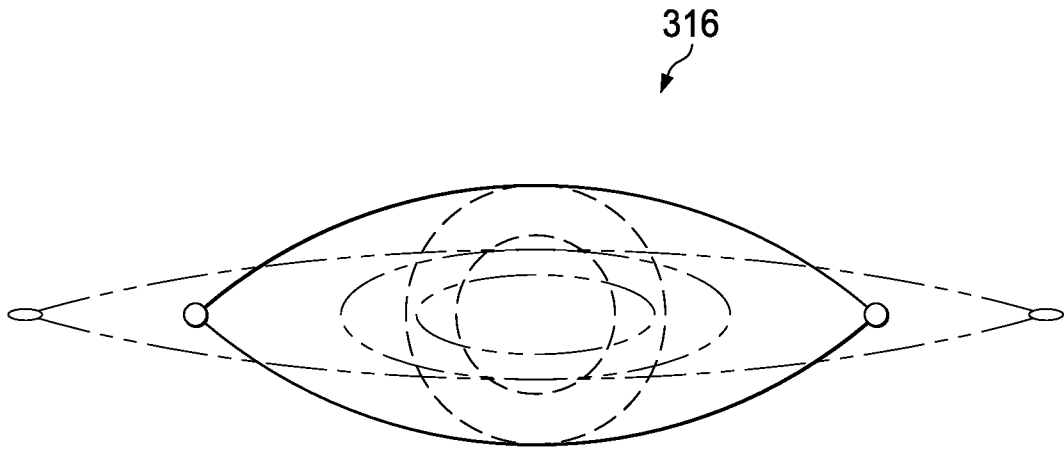
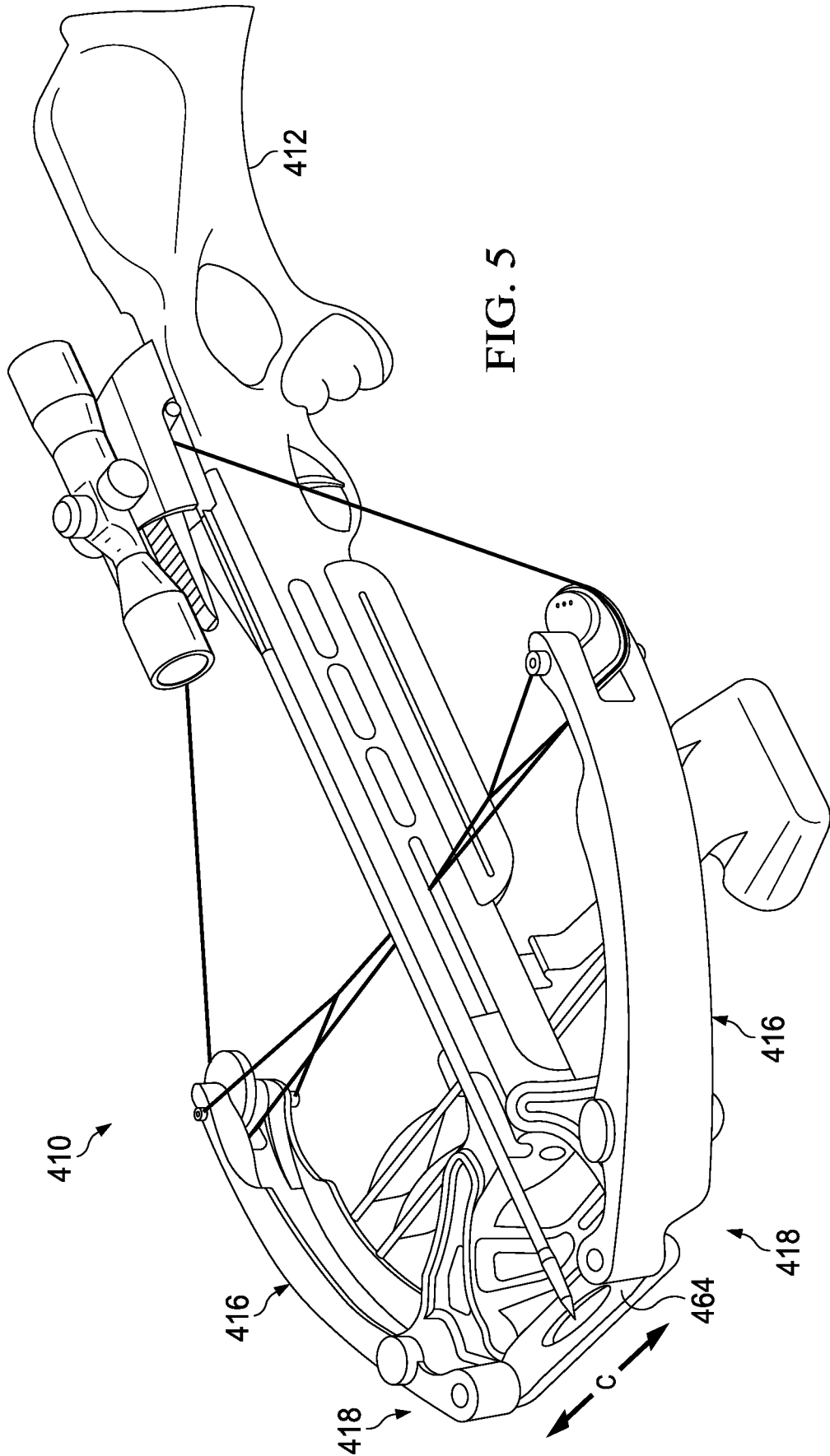

FIG. 4D



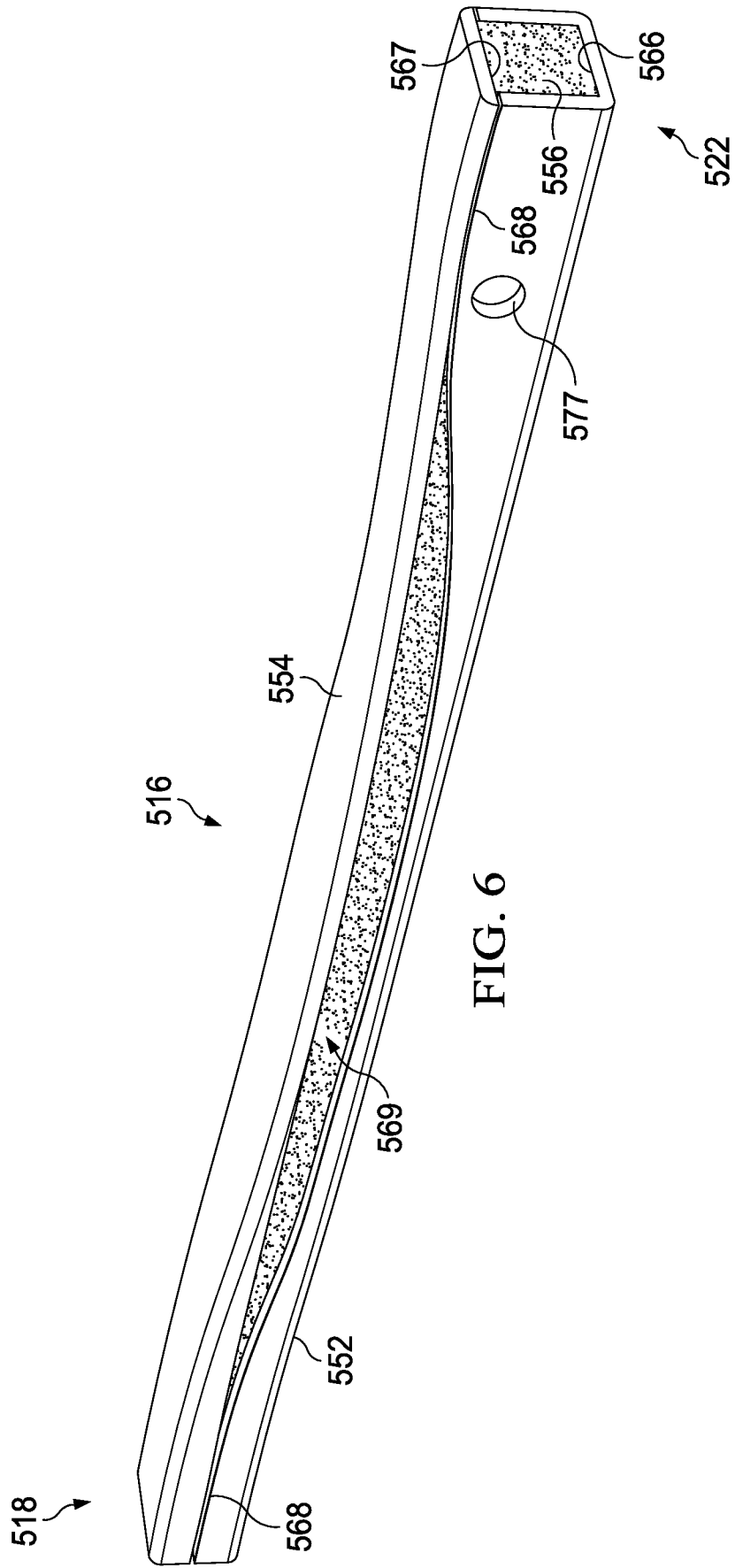

FIG. 6

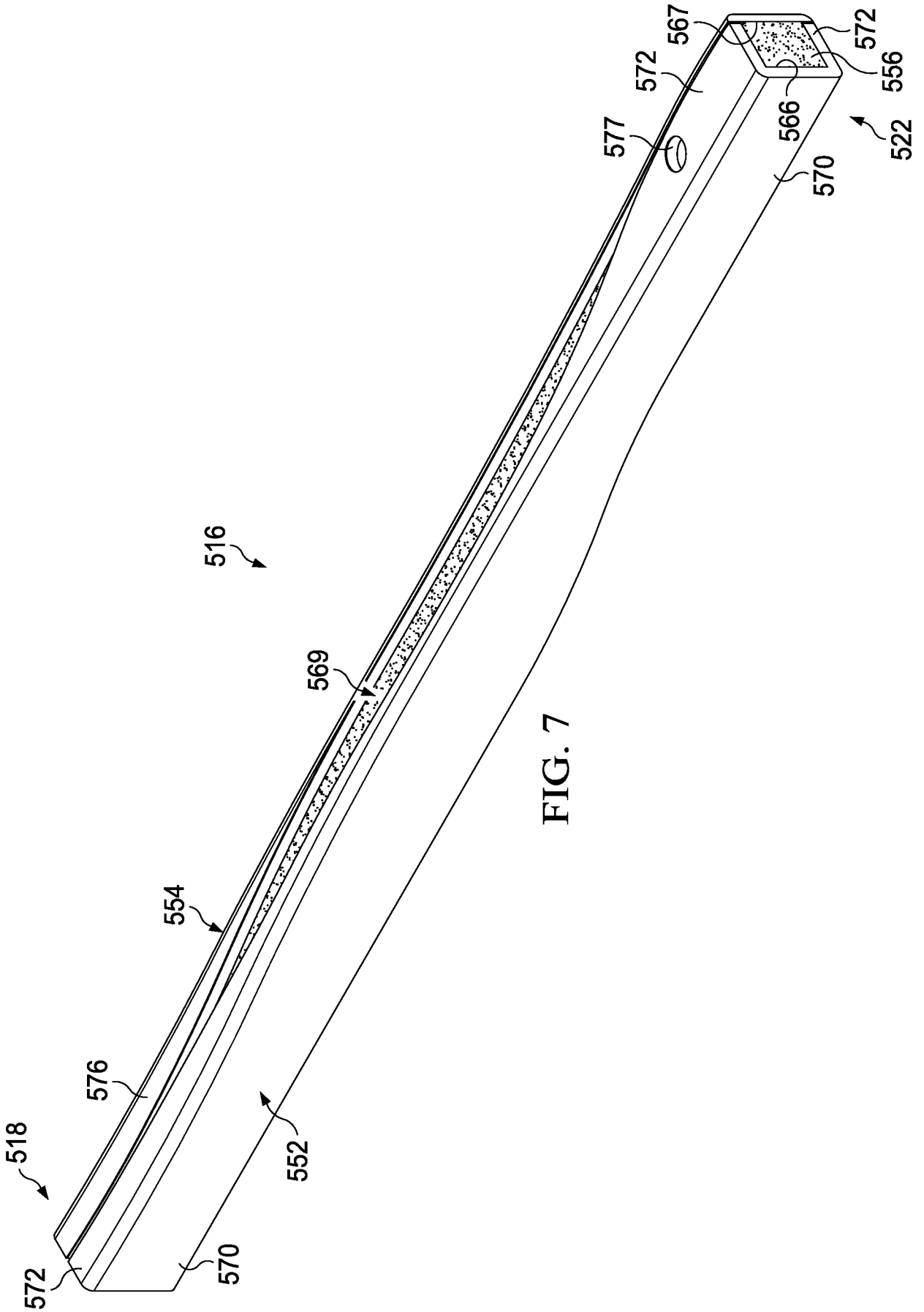

FIG. 7

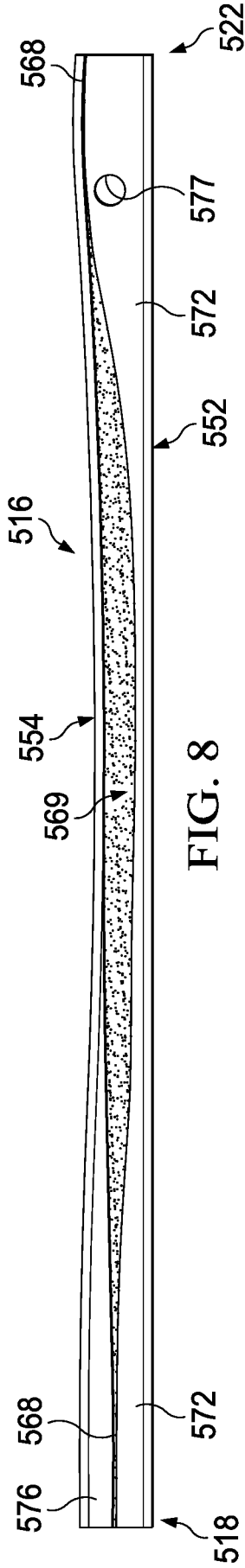

FIG. 8

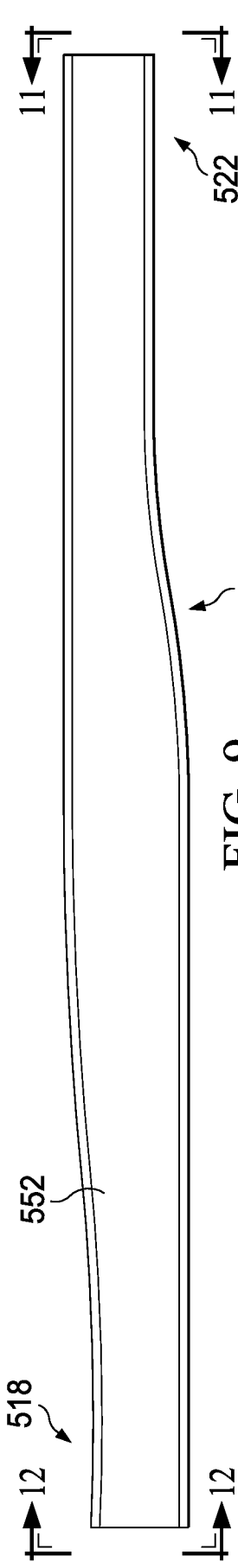

FIG. 9

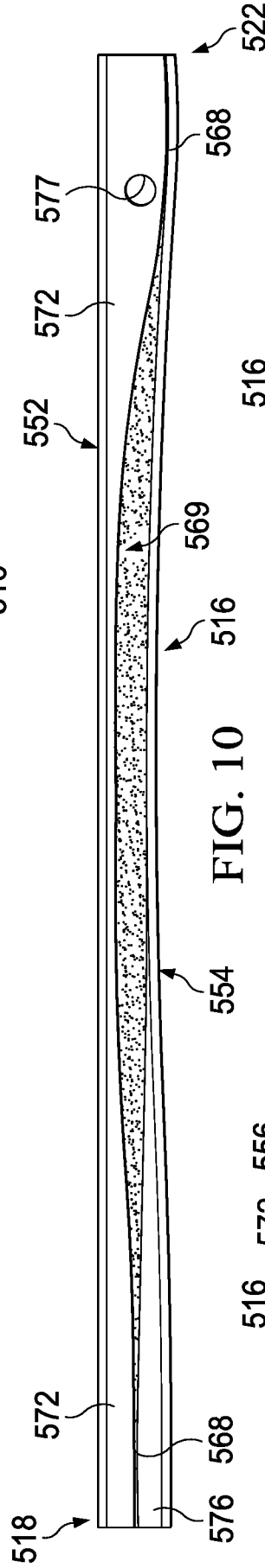

FIG. 10

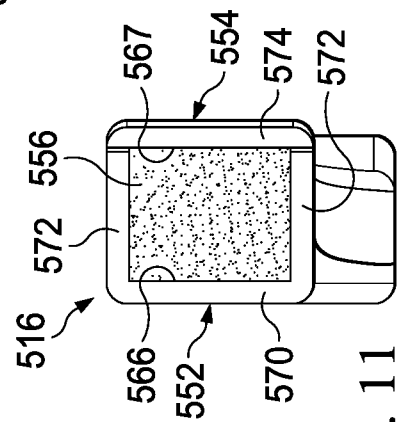

FIG. 11

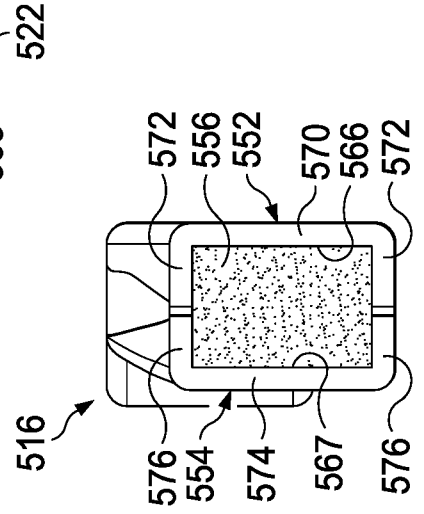

FIG. 12

FIG. 13

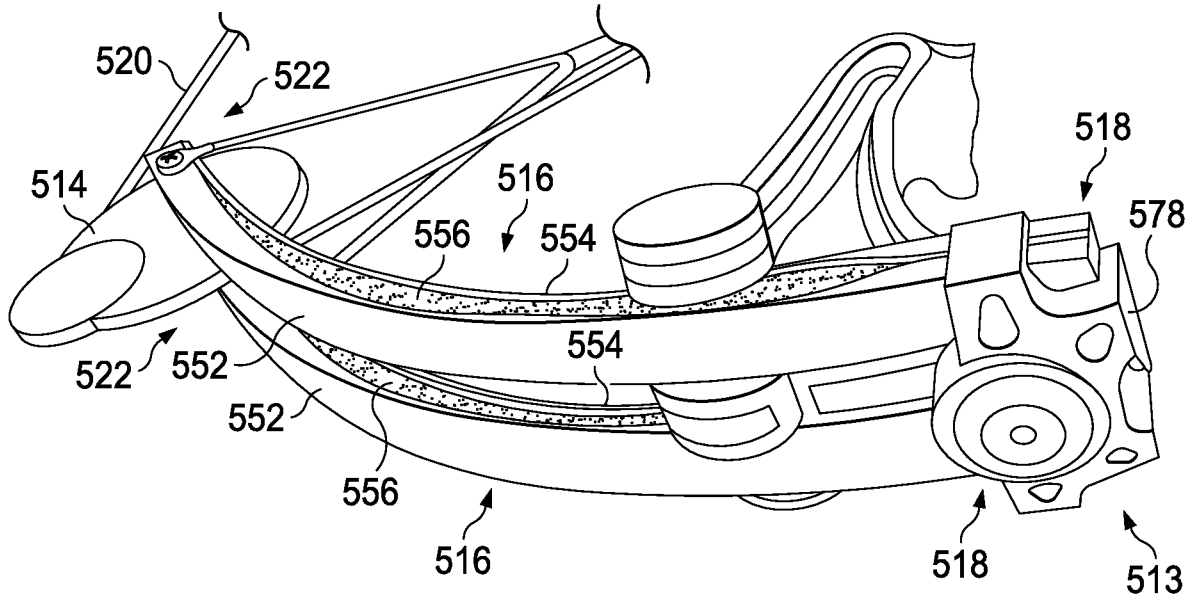
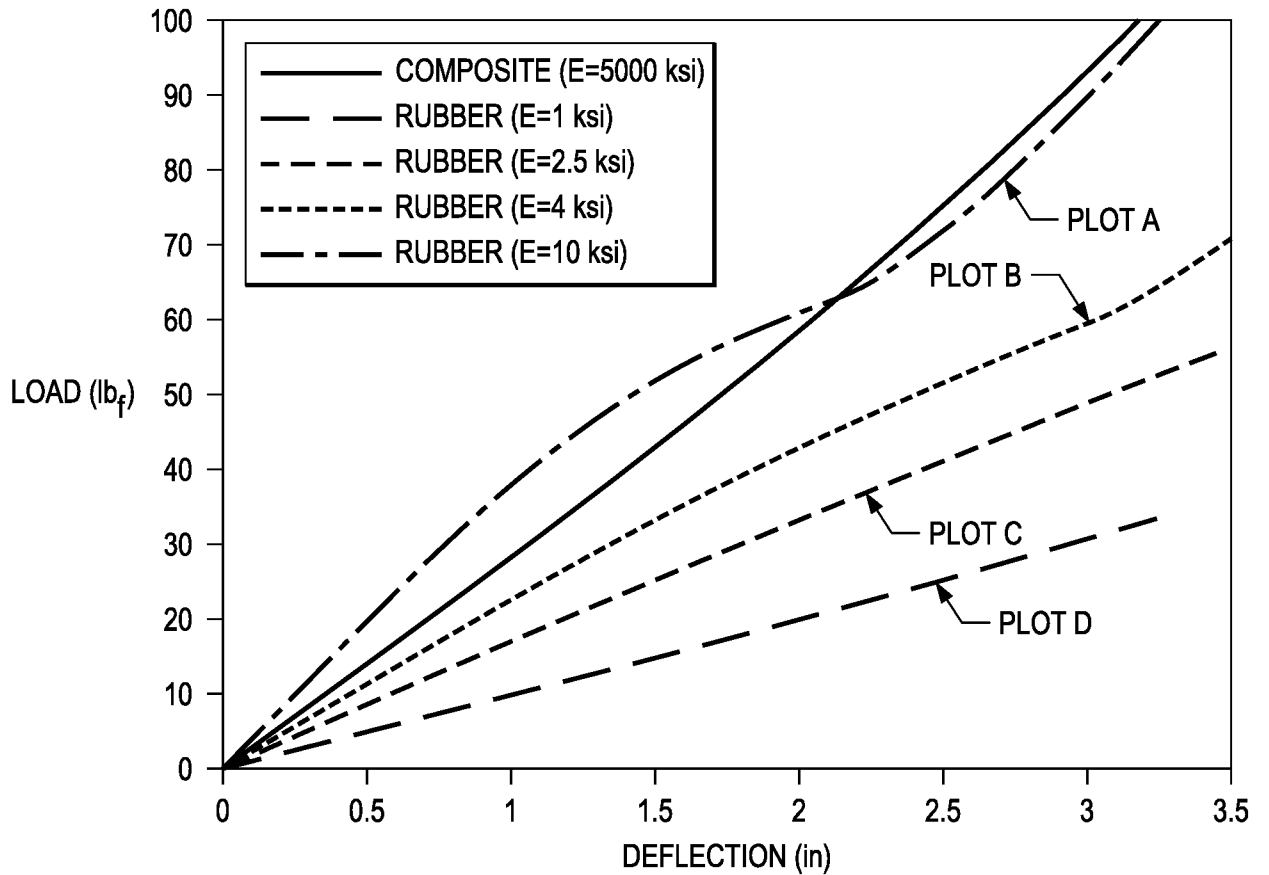

FIG. 14



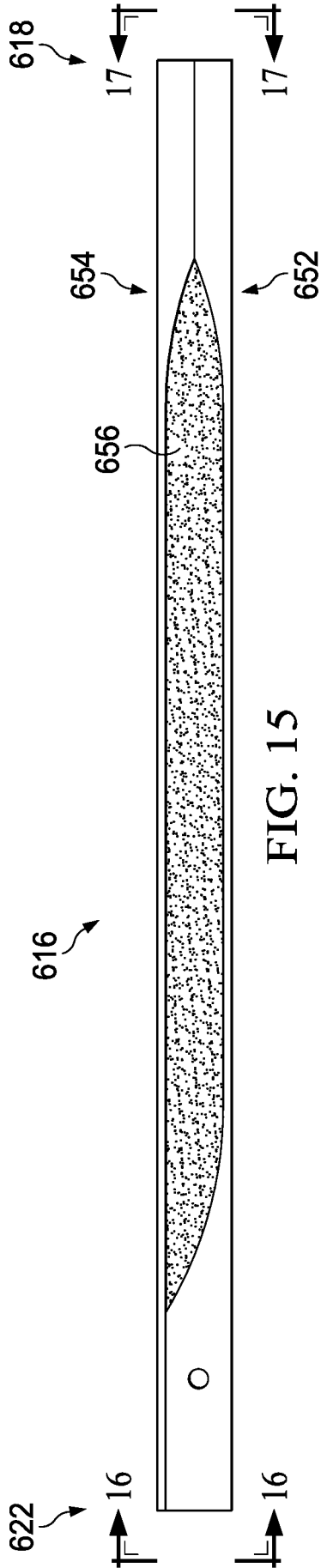

FIG. 15

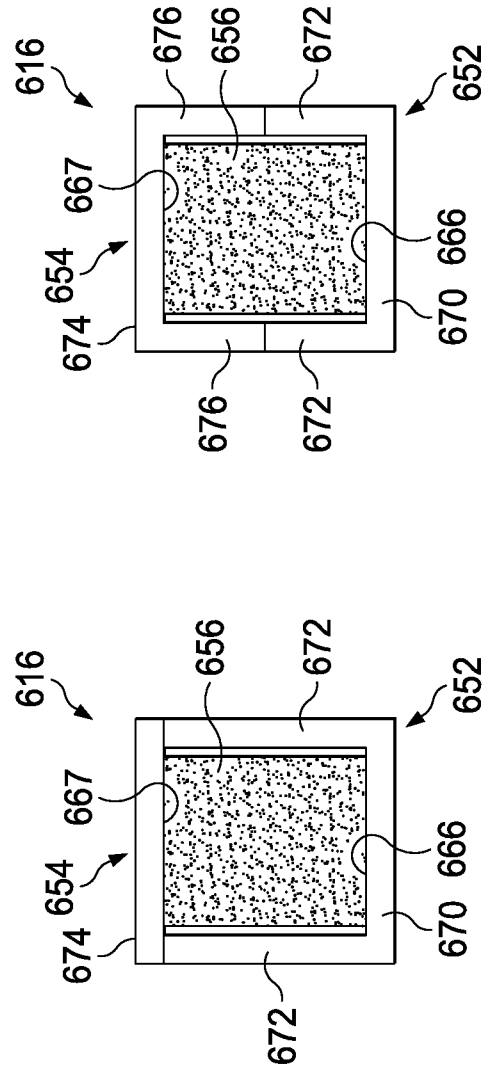

FIG. 17

FIG. 16

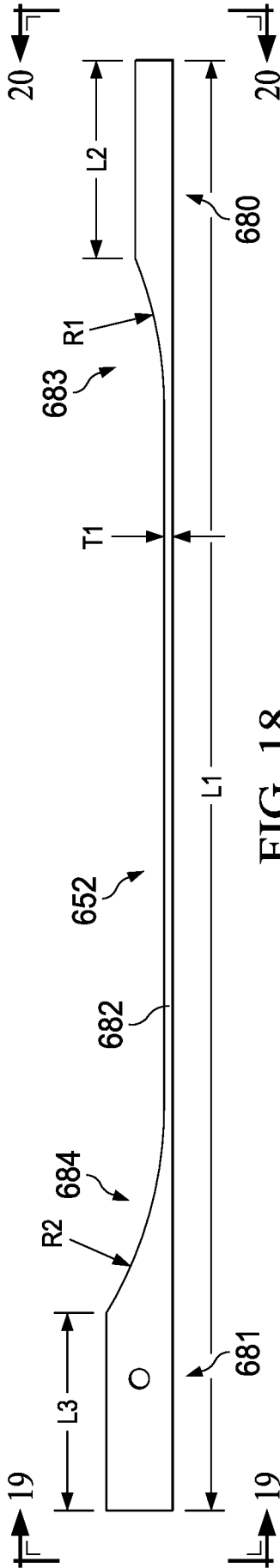

FIG. 18

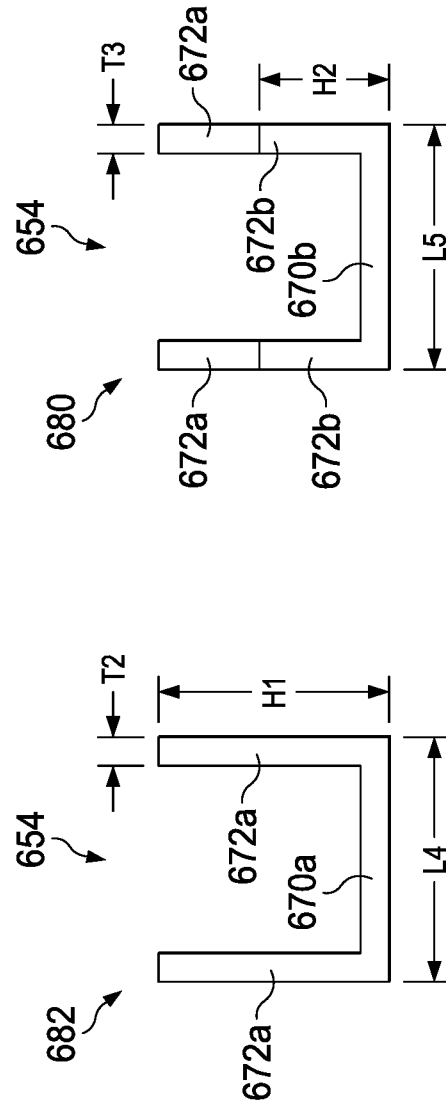

FIG. 19

FIG. 20

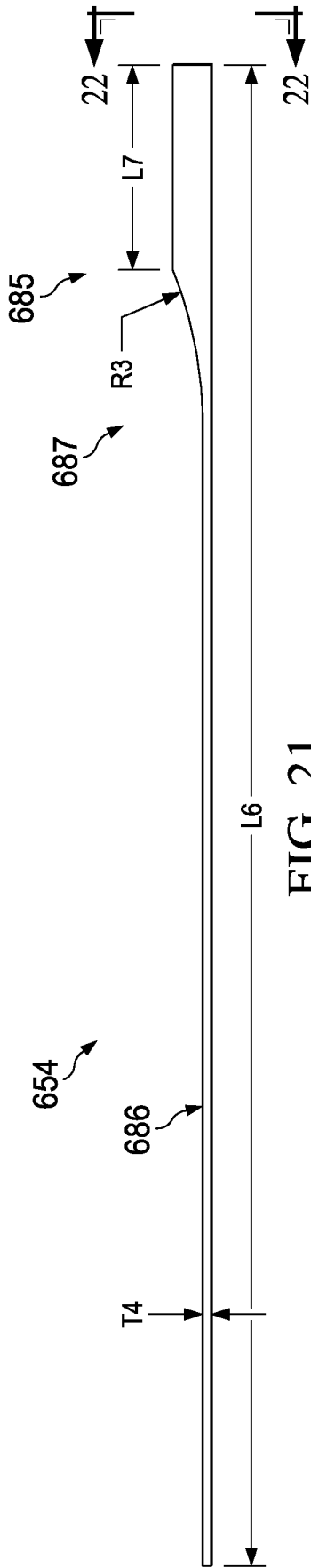

FIG. 21

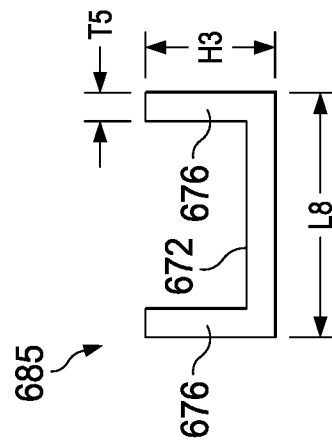

FIG. 22

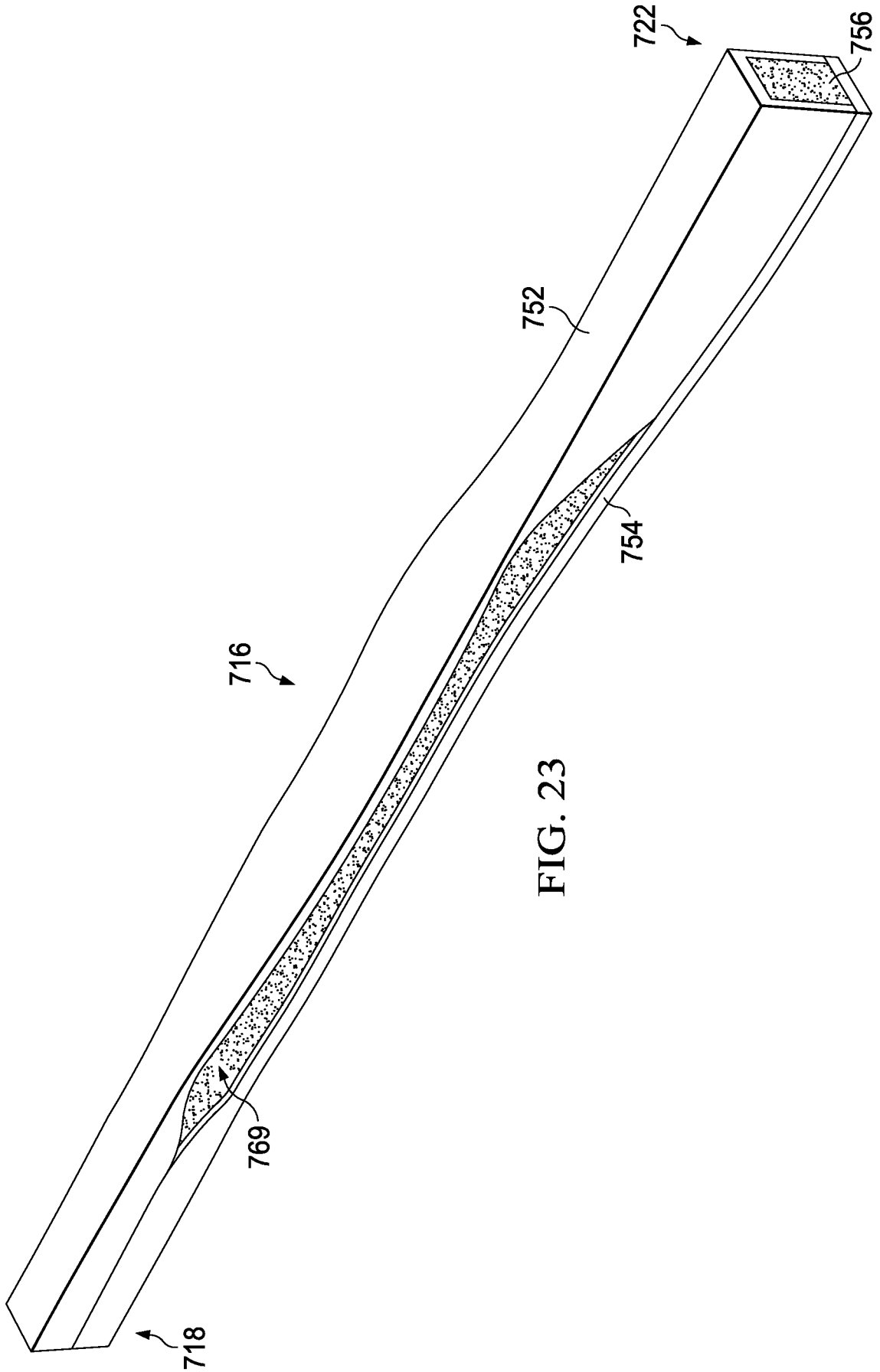

FIG. 23

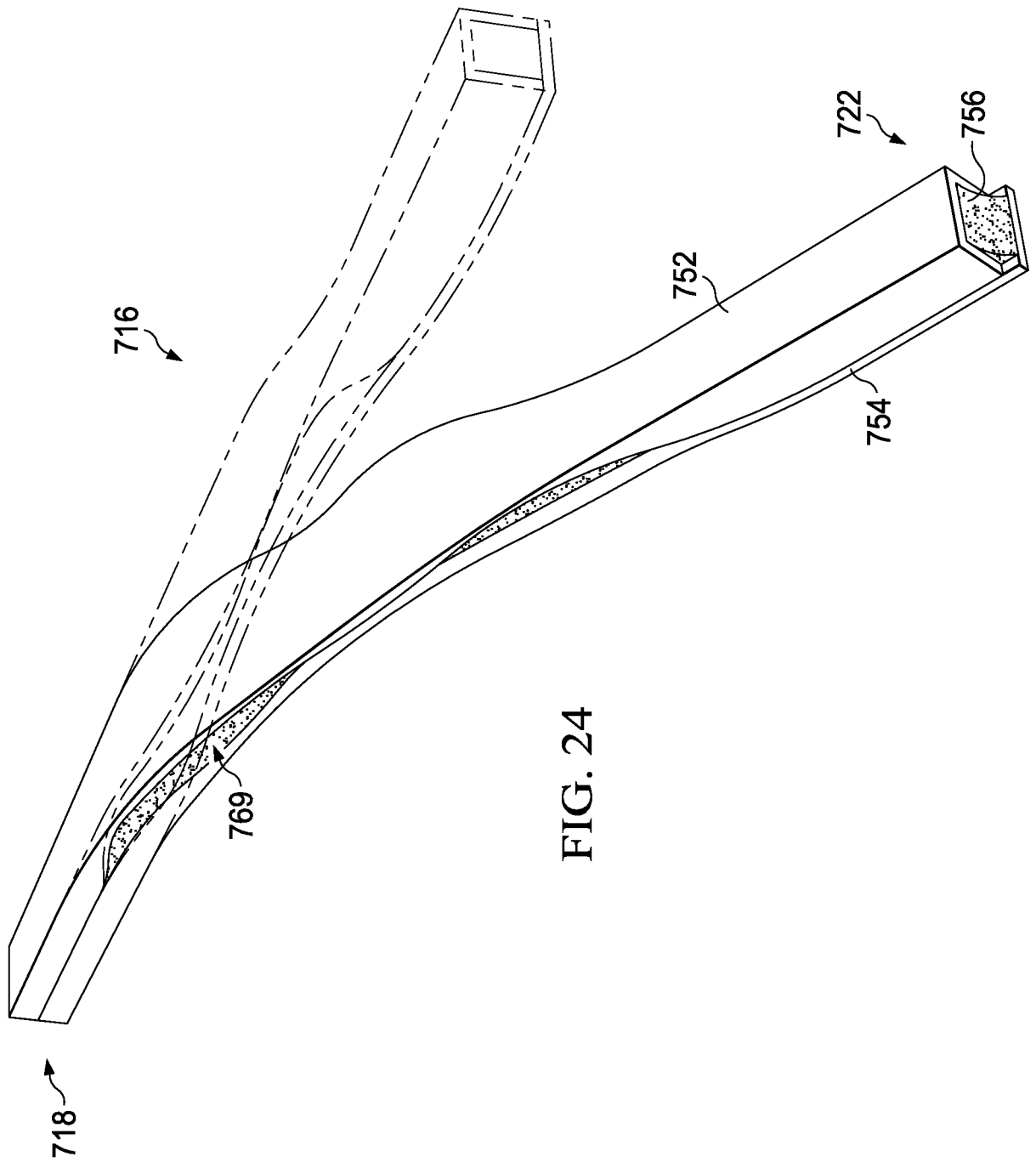

FIG. 24

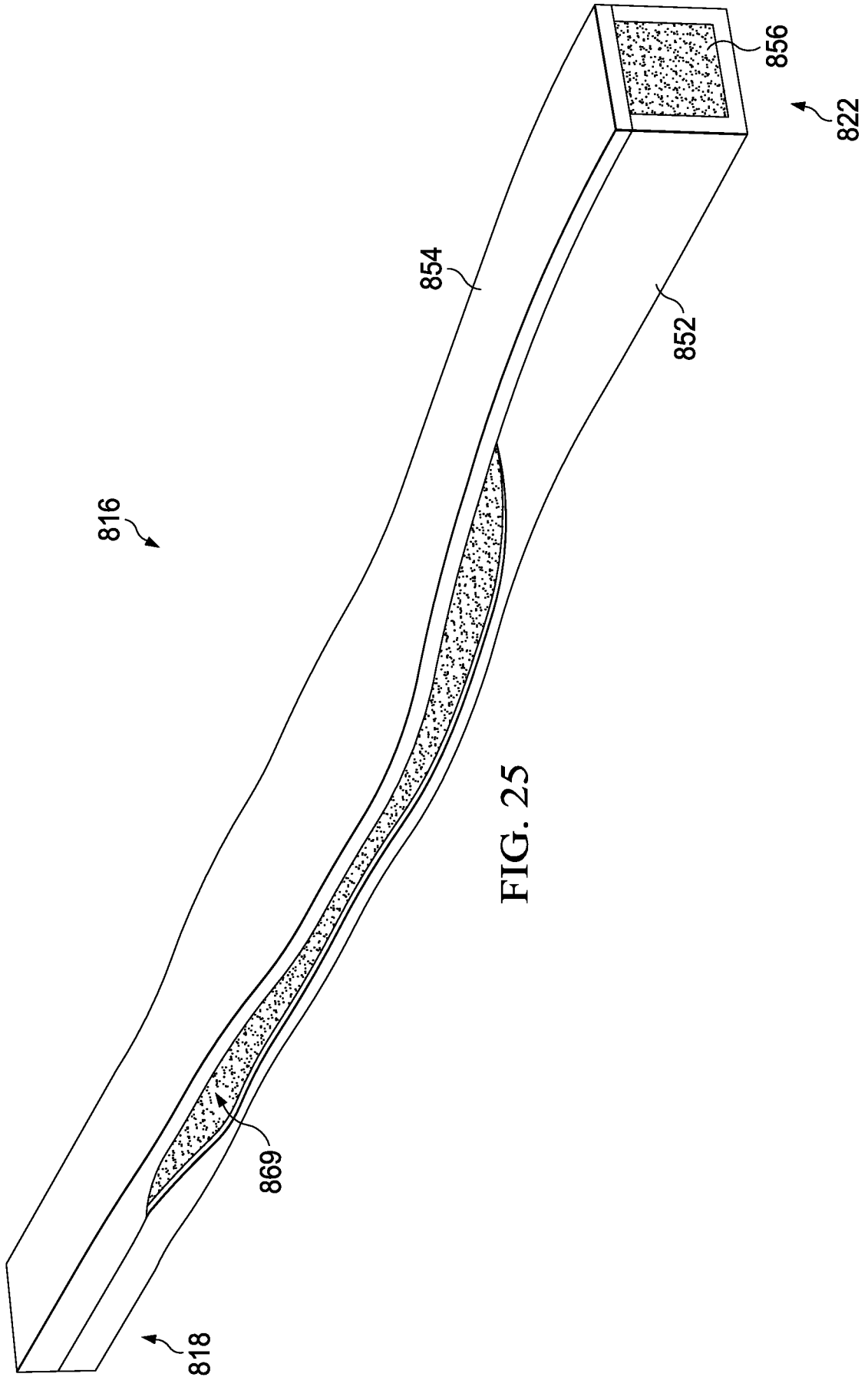

FIG. 25

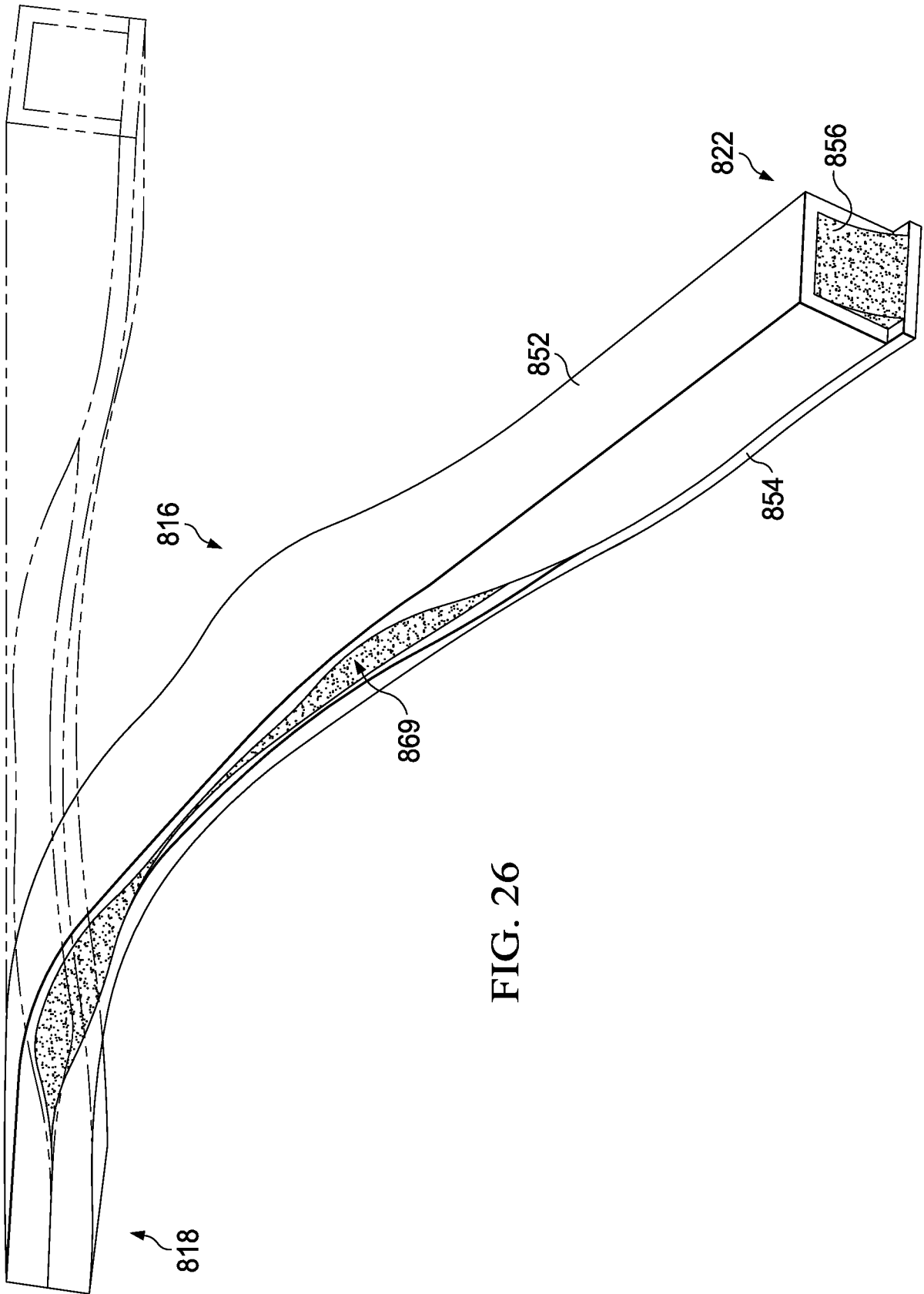
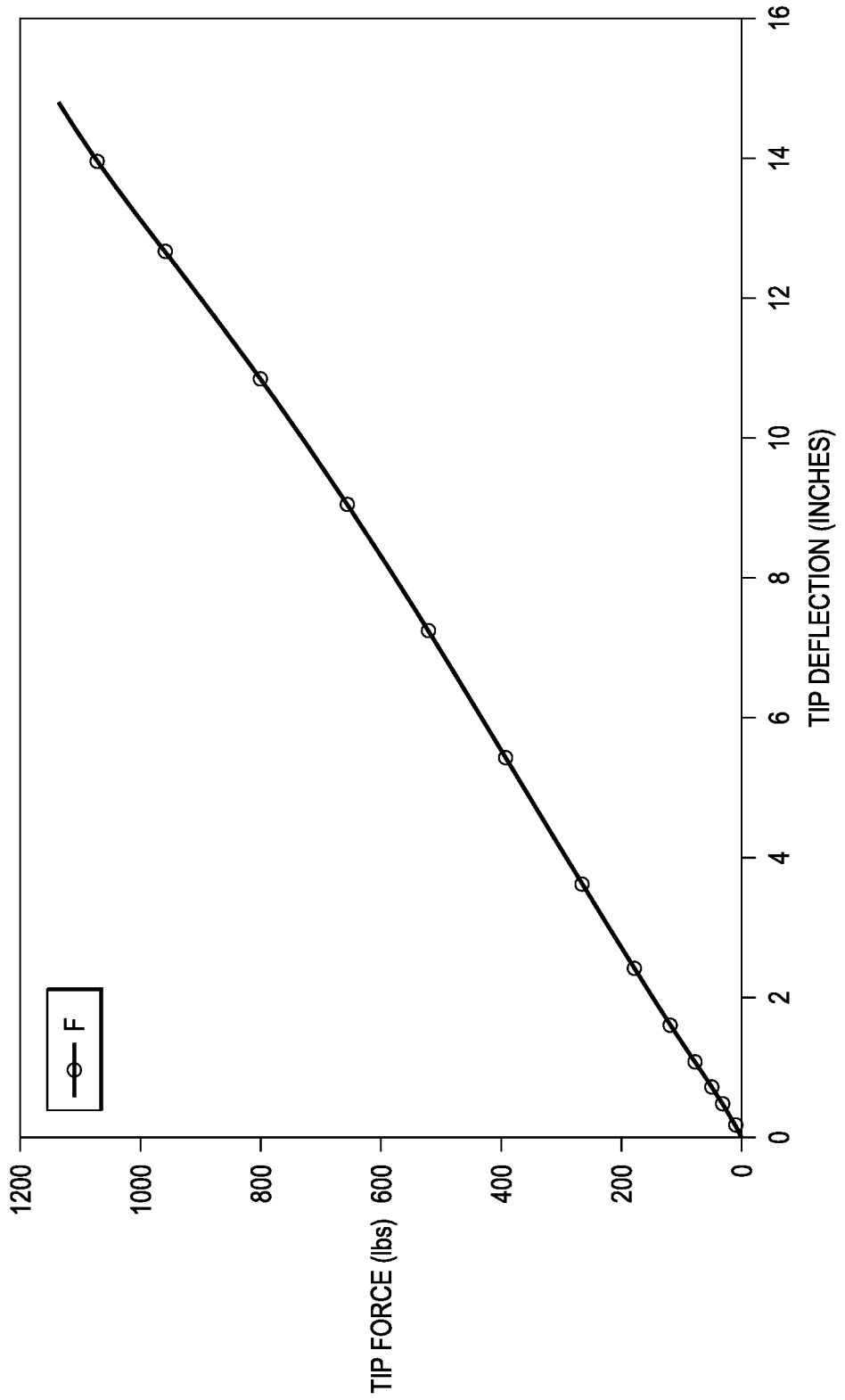

FIG. 26

FIG. 27



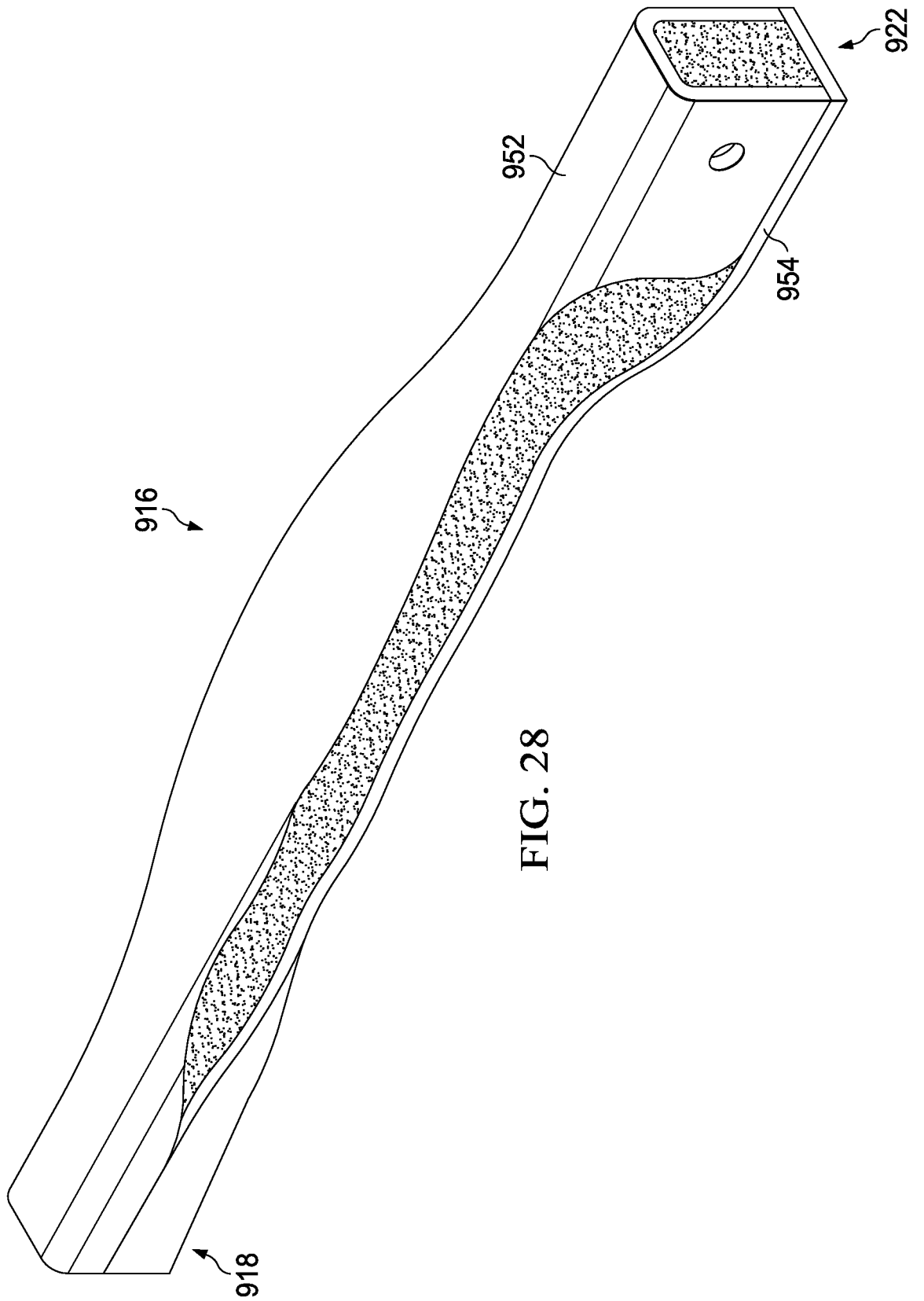

FIG. 28

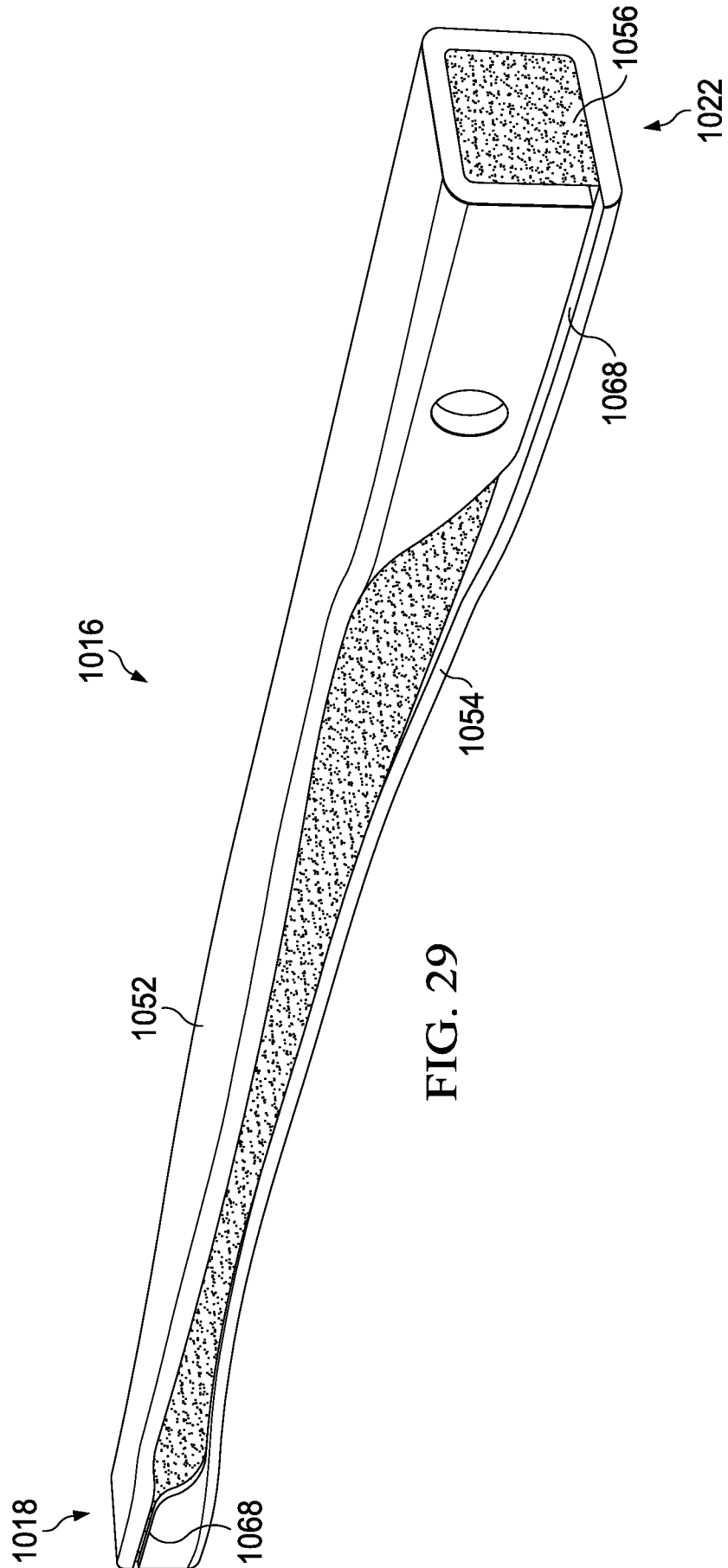

FIG. 29

