

(No Model.)

A. M. WHITNEY.
ROTARY TOBACCO CUTTER.

No. 417,962.

Patented Dec. 24, 1889.

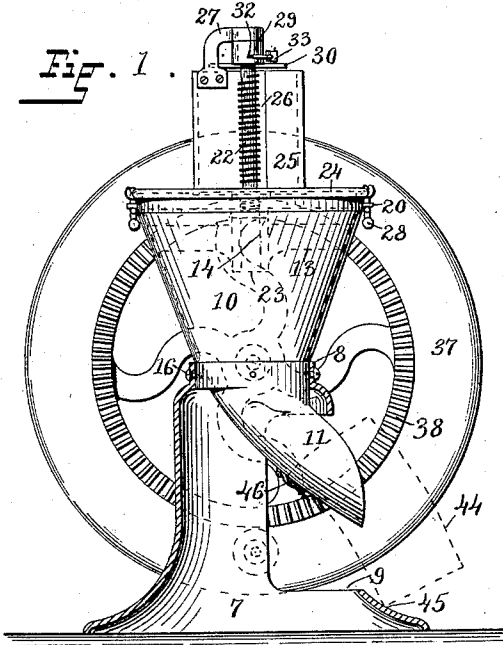

Fig. 1.

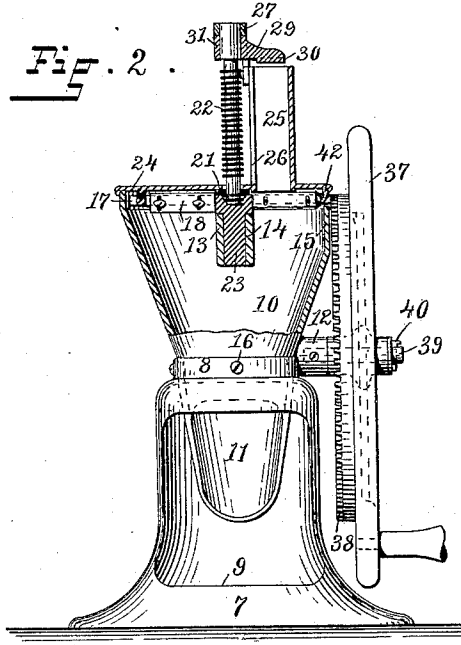

Fig. 2.

Fig. 3.

Fig. 4.

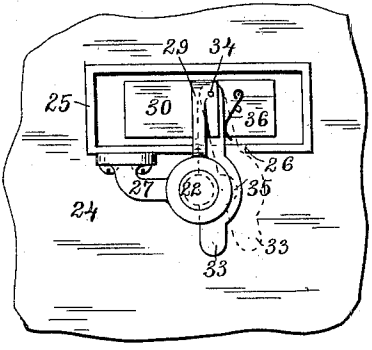
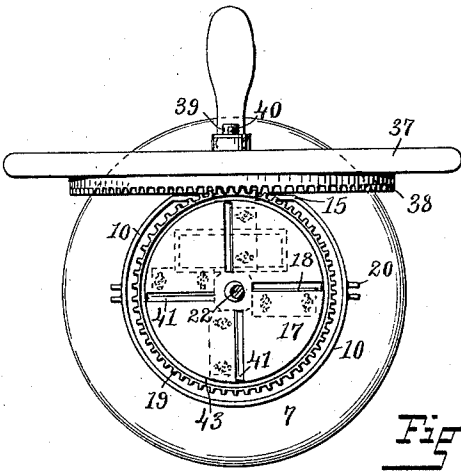
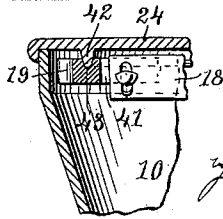

Fig. 5.

WITNESSES:
Char. H. Luther Jr
W. F. Bligh



INVENTOR:
Aubrey M. Whitney
Joseph A. Miller Dec
Attys

UNITED STATES PATENT OFFICE.

AUBREY M. WHITNEY, OF PROVIDENCE, RHODE ISLAND.

ROTARY TOBACCO-CUTTER.

SPECIFICATION forming part of Letters Patent No. 417,962, dated December 24, 1889.

Application filed November 8, 1886. Serial No. 218,226. (No model.)

To all whom it may concern:

Be it known that I, AUBREY M. WHITNEY, of the city and county of Providence, and State of Rhode Island, have invented certain new and useful Improvements in Rotary Tobacco-Cutters, of which the following is a full, clear, and exact description, reference being had to the accompanying drawings, forming part of this specification.

10 This invention relates to a machine for cutting or slicing tobacco into thin pieces, and is equally applicable for cutting other materials, such as vegetables.

15 The objects of my invention are to provide a cutter that is a self-feeder and can be easily manipulated by one hand of the operator, and that is very efficient in work and compact in form.

20 To the above purposes my invention consists, principally, in the automatic feeding mechanism and the peculiar construction of the catch-funnel and the connected discharge-chute, and of the support-stand for the superstructure, and in other novel constructions and arrangements of the parts of the device, all as hereinafter fully described and claimed.

25 In the accompanying drawings, illustrating my invention, Figure 1 represents a side elevation of my improved cutter, the support-stand of which is in central vertical section. Fig. 2 represents a front elevation of my device, with the feeding mechanism and the superstructure of the support-stand shown in central vertical section and the catch-funnel as broken away. Fig. 3 represents a top plan view of Fig. 1, with the cover omitted and the feed-bar in cross-section. Fig. 4 represents an enlarged detail top plan view of a portion of the cover with the feeding mechanism. Fig. 5 represents an enlarged detail sectional view of a portion of the catch-funnel, the cutter-disk, and the cover.

30 In the said drawings like numbers of reference designate corresponding parts throughout.

35 Referring to the drawings, the support-stand 7 is a hollow column having a flaring resting-base, and is formed with a circular top opening, around which is the flange or collar 8. The side of the stand 7 is provided

with a large opening 9, through which access is had to the interior thereof.

40 The catch-funnel 10 is a hollow truncated cone-shaped body inverted, and is provided at the small end or base thereof with an eccentrically-disposed discharge-chute 11, which is of an ordinary scoop shape and has its inner surface continuous with that of the catch-funnel, the base of the funnel from where the chute arises being of a perfect circular form. Upon the outside of the catch-funnel is a projection or arm 12. Across the interior of the funnel is disposed a cross-piece 13, provided with a journal-bearing 14. The catch-funnel is slightly flattened at 15 near the top and is cut away on the edge of the flat portion. At two opposite points on the exterior of the funnel are formed the forked lugs 20, which are designed for the purpose hereinafter described. This catch-funnel 10, together with the discharge-chute 11, the interior cross-piece 13, and the exterior arm 12 and lugs 20, are all cast in a single piece. This is an important and useful feature in this class of devices, since it serves to strengthen and condense the structure and to render less expensive the construction. The catch-funnel is set with the base thereof resting snugly within the collar 8, where it is held securely against movement by the screws 16, which may bind upon the exterior of the catch-funnel or may pass through the body thereof. In this position the discharge-chute projects downwardly through the opening 9 in a convenient position. Upon the back of the discharge-chute 11 is arranged a spring catch or finger 46, designed to receive and hold securely the edge of a bag, as 44, when placed over the chute, as hereinafter described.

45 The rotary cutter-disk 17 is a flat plate provided with four equidistant radial slots 41, in which are set the blades 18, which leave the outer ends of said slots open for the tobacco to fall through, as hereinafter described. This cutter-disk is cast with the radial peripheral cogs or gear 19, and is formed with the annular depression or groove 43 in the cutting-face thereof near the edge. Upon the under face of the disk is the central integral journal or shaft 23, which is journaled in the journal-bearing 14 of the cross-piece 13. The

blades 18 all have their cutting-edges disposed in the same direction and to the upper face of the disk. At the center of the cutting-face of the disk 17 is formed the screw-threaded socket 21.

22 is a shaft formed with a worm or screw thread running throughout the greater part thereof and is set into the socket 21 of the cutter-disk by means of a screw-thread and stands fixed at right angles to the disk and is rotated by the motion of said disk. The upper free end of the shaft 22 is enlarged and of a cylindrical form.

The cover 24 is flat and is provided with a depending annular tongue 42 near the edge and with a marginal flange, and is shaped suitably to rest upon the upper edge of the catch-funnel 10 and to house the cutting-face of the cutter-disk 17. The cover is provided with two hinged latches 28, which are disposed at diametrically-opposite points on the edge thereof and are designed to swing down and lock in the forked lugs 20, as clearly indicated in Fig. 1. These latches and lugs serve to hold the cover 24 securely in position, and the cover may be released for removal by merely swinging the latches outwardly and upwardly to clear the forks of the coating lugs in an evident manner. When the cover is mounted in position, the tongue 42 thereof is nested snugly in the groove 43 of the disk, so that while the disk revolves the particles of tobacco are thrown by the centrifugal force from the face of the disk against the tongue 42, from where they will fall through the slots 41 into the catch-funnel.

To one side of the center of the cover 24 is constructed the rectangular feed-box 25, which is formed integral with the said cover and stands normal thereto. The feed-box 25 is open at the top, and the bottom thereof opens and feeds directly onto the cutting-face of the cutter-disk 17 and within the field of the passing blades 18. In the side of the feed-box, opposite the center of the cover 24, is formed the vertical open way 26, which is open at the top. The rigid arm 27 is fixed firmly to the side of the feed-box 25, and at the upper free end of said arm is formed a journal box or bearing, in which the upper end of the feed-bar 22 is journaled, as shown, in order to prevent the feed-bar from wobbling when revolved. The feed-bar is readily removable from its mounting by unscrewing it from the socket 21 of the cutter-disk 17 and then passing it upward through the bearing in the arm 27.

The presser 29 is provided at one end with a flat plate 30, and at the other end is formed with a socket-eye 31, which is sufficiently large to allow the feed-bar to pass loosely therethrough. In the side of the presser is cut a slot 32, transverse to the axis of the socket-eye 31, and which extends from the exterior of the presser to the interior of the eye 31. The saddle-arm 33 is hinged in the slot by means of pivot 34, so that the curved sad-

dle portion 35 of the arm will lie in mesh with the worm or screw-threads of the feed-bar 22, with which the saddle-arm is pressed into constant engagement through the office of the spring 36, which is mounted upon the presser-plate 30. The presser-plate 30 lies within the area of the feed-box, and the presser extends through the open way 26 of said box, so that the presser is adapted to travel up and down within the feed-box in accordance with the direction in which the feed-bar is turned. The working of the presser in the open way 26 prevents the same from having a lateral or rotary motion, and causes the presser to maintain a rectilinear motion in its operations.

The presser 29, together with the saddle-arm 33, works up and down on the threads of the feed-bar like a nut, and the bar is easily removed therefrom by withdrawing the saddle-arm from out the slot 32 against the force of the spring, so as to disengage the arm from the feed-bar, which may then be slid through the socket-eye 31.

By virtue of the construction of the feed-screw bar 22, the presser 29, and the feed-box 25, and the actuating cutter-disk 17, the feeding mechanism is automatic in action, since the rotation of the cutter-disk the one way or the other will serve to feed the presser up or down, respectively, within the feed-box.

The cutter-disk 17 is rotated or driven by means of the hand-wheel 37, which is cast with the annular crown cog-gear 38, concentric therewith. The hand-wheel is journaled by means of a central eye upon the fixed journal or shaft 39, which is forced in a bored-out socket in the arm 12 and held therein by a set-screw. The hand-wheel is held on its journal 39 by the linchpin 40, and is turned by the operator manipulating the attached handle. The crown cog-gear 38 is placed in mesh with the peripheral cogs 19 of the cutter-disk 17 at the cut-away edge on the flattened side 15 of the catch-funnel, and the revolution of the hand-wheel serves to drive the cutter-disk in an obvious way.

From the foregoing description of the device its operation will be readily understood. The material or plug-tobacco that is to be cut or chopped is placed within the feed-box by first raising the presser clear of the feed-box, as in Figs. 1 and 2, and swinging it to one side, so as to give access to the interior of said box. The presser is then adjusted in position, so as to travel within the box, and the saddle-arm 33 is placed in mesh with the feed-bar. The hand-wheel is then turned in a direction to drive the blades with their cutting-edges first, and this serves to turn the feed-bar in a direction suitable to feed the presser gradually downward, whereby the plug-tobacco is gradually fed with a slight pressure to the cutting-face of the cutter-disk. The chips of cut tobacco fall into the catch-funnel, which leads them into the discharge-chute, from where they may be caught in a

suitable receptacle in a finished state. The end of the discharge-chute is at a convenient location and is of a handy shape to spring the mouth of a bag, as 44, (represented in broken lines in Fig. 1,) over it to catch the cut tobacco as it is delivered. When the bag 44 is placed in the position shown in Fig. 1, with the edge of the mouth caught under the spring-catch 46 and with the bottom thereof resting upon the curved resting-surface 45 of the support-stand, the bag will remain in place without being held, as the cut tobacco falls into it and fills the bag, which may then be removed. This convenient manner of placing and filling the bag is important, since it does not need the attention of the operator while being filled.

I construct the rotary cutter-disk 17 with the peripheral radial cogs 19, in preference to a bevel cog-gear, in order to obviate the evil of the particles of tobacco which necessarily become lodged in the teeth from interfering with the adjustment of the feed, since in the case of the bevel-gear the lumps of tobacco lodging in the cogs tend to press the cutter-disk upwardly, and so to increase the pressure of the tobacco upon the disk, thereby interfering with the proper feeding of the same. In the use of the radial cogs on the cutter-disk the presence of lumps of tobacco formed in the cogs will cause the disk to be pressed to one side of the intermeshing gear 38 of the hand-wheel, in which case the feed will be in no wise disturbed. Again, to further obviate the bad effect of the tobacco lodging in the cogs of the gears, I have provided a very efficient excluding means in the tongue 42 of the cover and the groove 43 of the disk, whereby the particles of loose tobacco which fall upon the cutting-face of the disk and would otherwise find their way to the cogs of the gears are thereby caught and fall down into the catch-funnel 10, as before described.

The pitch of the worm or the screw-threads of the feed-bar 22 may be varied in order to regulate the pressure with which the tobacco is fed to the cutter-disk. In any case the pressure should not be sufficient to impede the rotation of the cutter-disk. The greater the number of blades used the greater will accordingly have to be the pitch of the screw-threads, so that the feed may be fast enough to supply the blades. By virtue of the automatic feed and the consequent pressure therein exerted I am enabled to work the cutter with unusually high speed, and the actual use of the device shows that the four cutter-blades may be used with the greatest advantages.

My improved form of cutter provides a durable machine that is neat and portable, and one that may be rapidly and efficiently worked by one hand of the operator. Obviously the device may be employed to cut other material than tobacco, and will prove equally efficient.

There may be various modifications made

in the parts of my device without, however, making a substantial departure from the spirit of the invention as herein described 70 and claimed.

Having thus described my invention, I claim as new and desire to secure by Letters Patent—

1. The combination, with a suitably-mounted rotary cutter-disk provided with a set of blades and driving means, of a feed-screw bar mounted in a central screw-threaded socket formed in the said disk, a presser actuated by said bar, a cover suitably supported over the cutting-face of said disk and provided with a feed-box made integral therewith, said feed-box opening onto the disk and provided with an open way in the side thereof, and a fixed arm secured upon said feed-box and provided with a journal-box adapted to receive the free end of the feed-bar, substantially as described. 75

2. The combination, with a hollow truncated-cone-shaped catch-funnel and a scoop-shaped discharge-chute formed integral therewith and extending from the small end thereof, of an annular ridge or collar cast around the juncture of the said funnel and chute, and a hollow supporting-stand provided with a circular opening at the top adapted to receive and seat the said ridge or collar and provided with a side opening for the discharge-chute to project through, substantially as and for the purpose herein described. 80

3. The combination, with a support-stand and a catch-funnel provided with a discharge-chute and a lateral arm and an internal cross-piece, all cast integral therewith, of a rotary cutter-disk provided with blades and journaled in said cross-piece, a cogged gear concentric with said disk and turning therewith, and a hand-wheel provided with a gear-wheel and journaled on the arm of the catch-funnel, the said gears in mesh, substantially as described, whereby the turning of the hand-wheel may drive the cutter-disk. 85

4. The combination of a hollow support-stand having a circular top opening and a lateral opening, a conical catch-funnel provided with an integral discharge-chute and an integral exterior arm and interior cross-piece, the catch-funnel securely mounted in the top opening of the support-stand, a rotary cutter-disk having blades and provided with peripheral cogs and a central journal, said journal journaled in said cross-piece, and a hand-wheel journaled on the arm of said catch-funnel and provided with a crown cog-gear in mesh with the cogs upon said disk, substantially as described. 90

5. The combination of a support-stand and a superposed catch-funnel provided with a discharge-chute having a spring-catch thereon and provided with an external arm and an internal cross-piece, the forked lugs cast on said catch-funnel, said catch-funnel cut away upon one side thereof, a rotary cutter-disk journaled upon said cross-piece and provided with peripheral cogs, a hand-wheel journaled 95

- on the said arm and having a concentric crown gear-wheel in mesh with the cogs on said disk, the feeding mechanism, substantially as described, and a cover for said disk
- 5 and provided with an integral feed-box and with hinged latches locking with said forked lugs, all constructed and operating substantially as described.
6. The combination, with the rotary cutter-disk 17, suitably mounted and provided with a set of blades 18, of the cover 24, suitably supported and provided with the feed-box 25, the feed-bar 22, the arm 27, and the presser 29, traveling on said bar, substantially as described.
- 15 7. The combination, with the rotary cutter-disk 17, suitably mounted and provided with the openings 41 and the blades 18 and having the concentric annular groove 43, of the feed-bar 22, provided with the presser 29, the cover 24, suitably supported and provided with the annular tongue 42, and the feed-box 25, having the open way 26 and the arm 27, all substantially as described.
- 20 8. The single casting comprising the catch-funnel 10, the discharge-chute 11, the internal cross-piece 13, having the journal-bearing 14, and the forked lugs 20, all substantially as and for the purpose herein described.
- 25 9. The combination, with the rotary cutter-disk 17, provided with a set of blades and the journal 23, of the catch-funnel 10, provided with the discharge-chute 11, and having the internal cross-piece 13, formed with the
- 35 journal-bearing 14 for said journal 23, the

support-stand 7, provided with the collar 8 and opening 9 and having the resting-surface 45, and means for driving the cutter-disk, substantially as described.

10. The combination, with the rotary cutter-disk 17, provided with blades and the peripheral gear 19 and having the journal 23, of the catch-funnel 10, provided with the discharge-chute 11 and the internal cross-piece 13, having the journal-bearing 14, and the external arm 12 on the funnel, the support-stand 7, and the hand-wheel 37, provided with the crown cog-gear 38 and mounted on the journal 39, all substantially as described.

11. The combination, as hereinbefore set forth, with a rotary cutter-disk and a feed-screw bar driven thereby, of a presser provided with a socket-eye to receive the said bar and having a slot leading into the socket-eye, a saddle-arm pivoted upon the presser and adapted to take through the slot and engage the said bar, and a cover for the cutter-disk, said cover provided with a feed-box having a longitudinal opening formed therein, the said presser extending through the opening into the interior of the feed-box, substantially as and for the purpose herein described.

In witness whereof I have hereunto set my hand.

AUBREY M. WHITNEY.

Witnesses:

J. A. MILLER, Jr.,
M. F. BIGH.