

No. 752,756.

PATENTED FEB. 23, 1904.

A. H. CHRISTIE.

SUIT CASE.

APPLICATION FILED JULY 16, 1903.

NO MODEL.

Fig. 2.

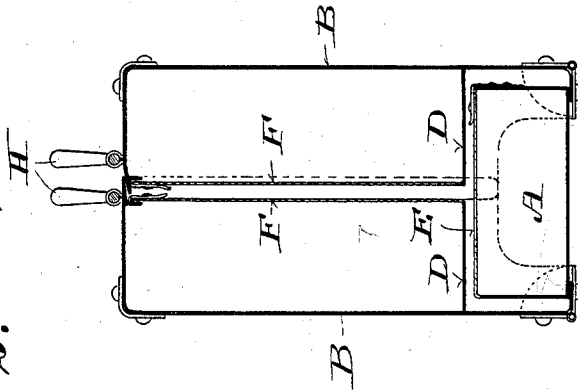
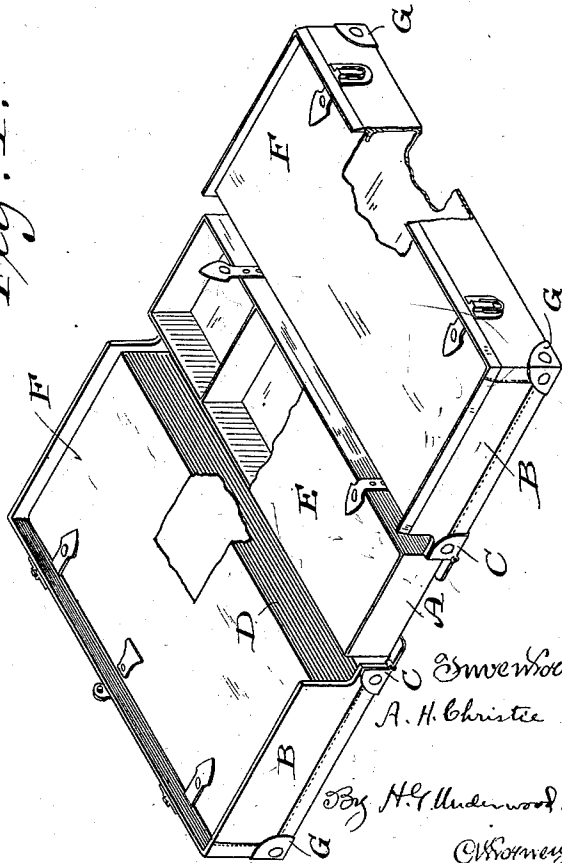

Fig. 1.



Witnesses
Geo W. Young.
H. E. Oliphant

Inventor:
A. H. Christie
By H. T. Underwood.
Attorney

UNITED STATES PATENT OFFICE.

ATHELSTAN H. CHRISTIE, OF MILWAUKEE, WISCONSIN.

SUIT-CASE.

SPECIFICATION forming part of Letters Patent No. 752,756, dated February 23, 1904.

Application filed July 16, 1903. Serial No. 165,735. (No model.)

To all whom it may concern:

Be it known that I, ATHELSTAN H. CHRISTIE, a citizen of the United States, and a resident of Milwaukee, in the county of Milwaukee and State of Wisconsin, have invented certain new and useful Improvements in Suit-Cases; and I do hereby declare that the following is a full, clear, and exact description thereof.

My invention has for its object to provide economical baggage of the suit-case species having bottom trays independent of all the other compartments of the baggage and to which ready access is had when said baggage is opened, the trays being partitioned or otherwise and preferably provided with lids. Hence said invention consists in a suit-case having the structural peculiarities hereinafter particularly set forth with reference to the accompanying drawings and subsequently claimed.

Figure 1 of the drawings represents a perspective view of an open suit-case made in accordance with my invention, and Fig. 2 a transverse sectional view of the suit-case closed.

Referring by letter to the drawings, A indicates a rectangular bottom tray, and B each of a pair of opposite angular compartments in a suit-case of the kind to which my invention relates. The compartments are longer than the tray to project beyond the ends of same, and flat opening outside hinges C connect said compartments with the base of said tray, each hinge being preferably of the specific construction set forth in my application for patent filed January 10, 1903, Serial No. 138,258.

One of the compartments B laps the other when the suit-case is closed, and both of said compartments are then at right angles to the bottom tray, which they encompass; but when said suit-case is open the aforesaid compartments are on the same horizontal plane as said tray, as shown in Fig. 1, the stock of their sides and that of the tray-bottom being lap-jointed, as shown in Fig. 2, or in one piece, as may be found most convenient in practice.

The tray A is of the same depth throughout and in upright position of the closed case. The bottoms D of its compartments B are parallel to said tray over the same, at which time their ends lap those of said tray and one another.

The tray A is shown provided with a lid E, and lids F are also shown in the compartments B of the case, all of said lids being suitably hinged and held closed by fastening devices common in the art of baggage.

Corner-protectors G and handles H are employed in connection with the case-compartments B, and the case as a whole is preferably frameless.

Having thus described my invention, what I claim as new, and desire to secure by Letters Patent, is—

1. A suit-case comprising a rectangular bottom tray, a pair of opposite angular compartments longer than the tray to project beyond the ends of same, and outside flat opening-hinges connecting said compartments and the base of said tray, whereby when the suit-case is open the tray and compartments are on the same horizontal plane, the aforesaid compartments being parallel and encompassing the tray when the suit-case is closed.

2. A suit-case comprising a rectangular lid-covered bottom tray, a pair of opposite angular compartments longer than the tray to project beyond the ends of same, and outside flat opening-hinges connecting said compartments and the base of the tray.

3. A suit-case comprising a rectangular bottom tray, a pair of opposite angular compartments longer than the tray to project beyond the ends of same, bottoms and lids in the compartments, and outside flat opening-hinges connecting the compartments and the base of the tray, the bottoms in said compartments being parallel to said base of the tray over the latter when the suit-case is closed.

4. A suit-case comprising a rectangular base, a pair of opposite angular compartments longer than the base to project beyond the

ends of same, and outside flat opening-hinges
connecting the compartments and base that
are on the same horizontal plane when the
suit-case is open, said compartments being
5 parallel and encompassing said base when said
suit-case is closed.

In testimony that I claim the foregoing I

have hereunto set my hand, at San Francisco,
in the county of San Francisco and State of
California, in the presence of two witnesses.

ATHELSTAN H. CHRISTIE.

Witnesses:

A. E. POLLEXFEN,

S. M. BUTTERS.