

April 26, 1932.

E. STUMP

1,855,895

HYDRAULIC CLEANER CONTROL

Filed Dec. 13, 1929

2 Sheets-Sheet 1

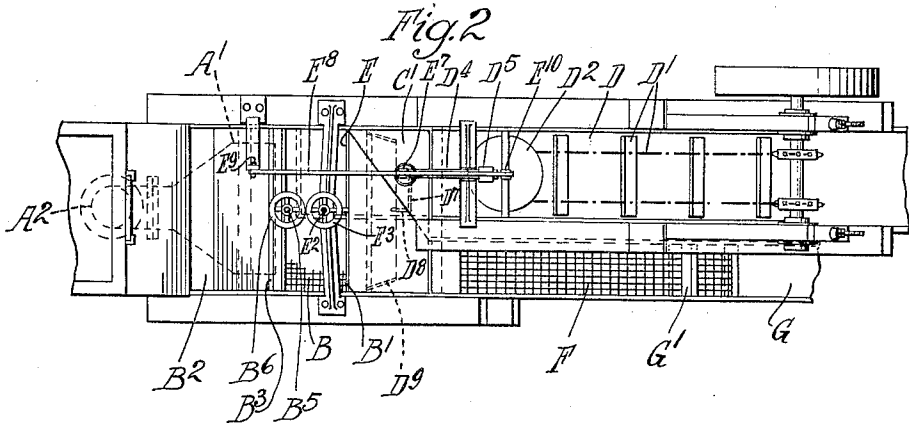
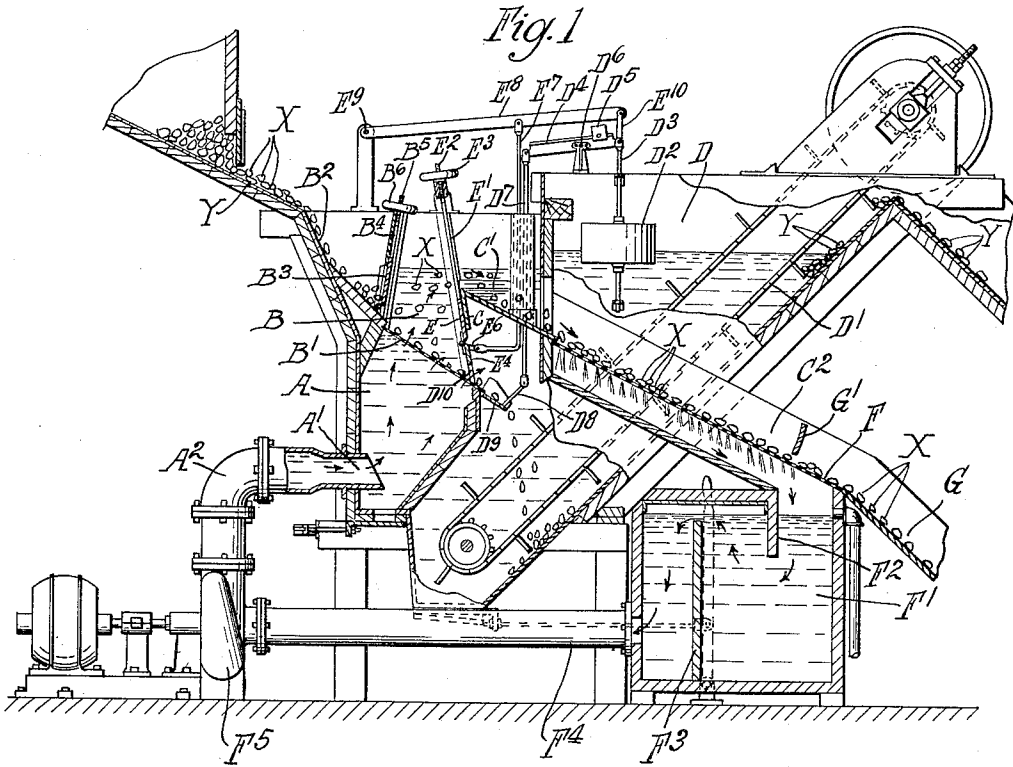

Inventor
Earl Stump
by Parker & Carter
Attorneys

April 26, 1932.

E. STUMP

1,855,895

HYDRAULIC CLEANER CONTROL

Filed Dec. 13, 1929

2 Sheets-Sheet 2

Fig. 3

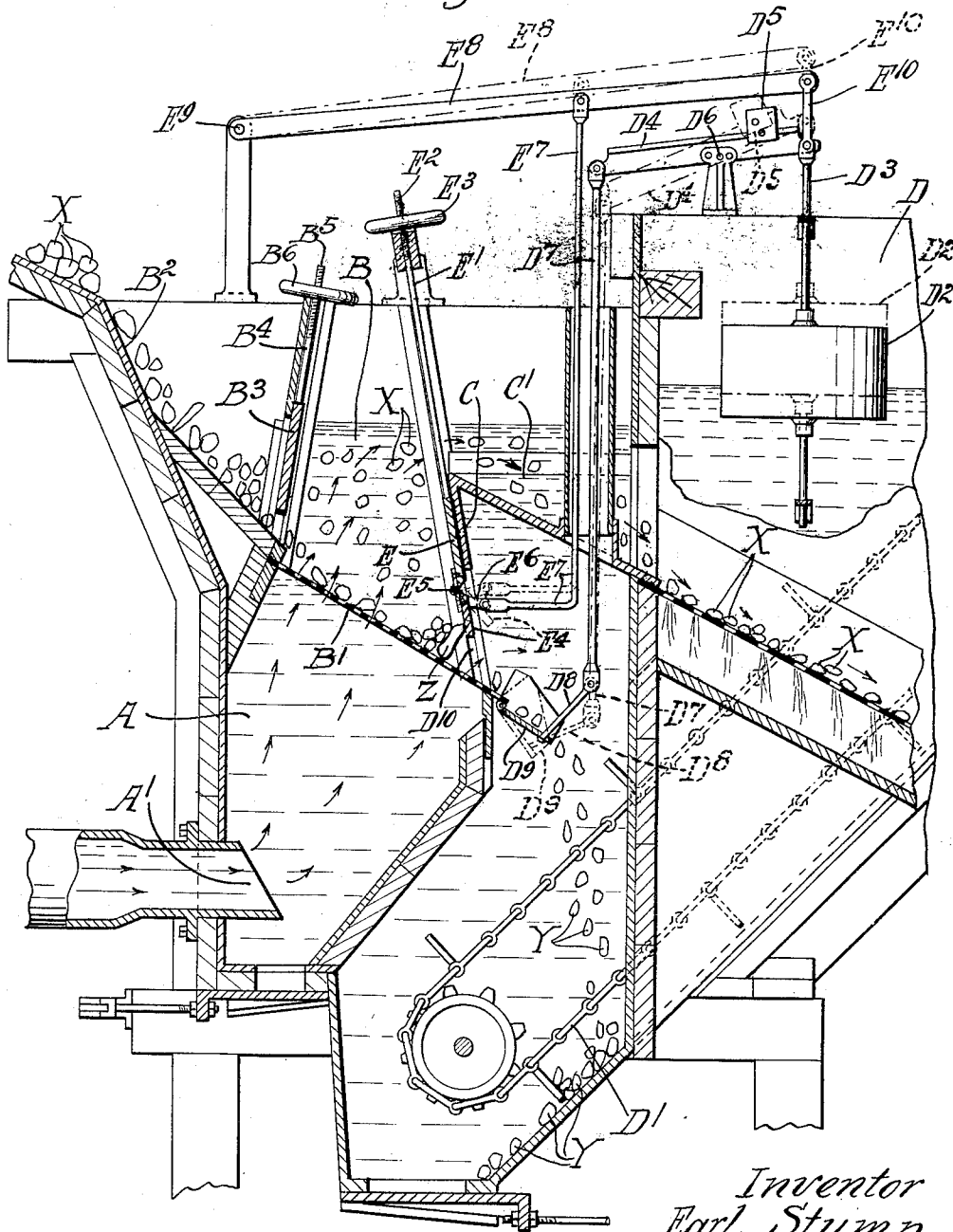

Inventor
Earl Stump
by Parker & Carter,
Attorneys

UNITED STATES PATENT OFFICE

EARL STUMP, OF CHICAGO, ILLINOIS, ASSIGNOR TO ROBERTS AND SCHAEFER COMPANY, OF CHICAGO, ILLINOIS, A CORPORATION OF ILLINOIS

HYDRAULIC CLEANER CONTROL

Application filed December 13, 1929. Serial No. 413,717.

This invention relates to an automatic control for a material cleaner. In the form illustrated herewith, the automatic control is particularly applied to a hydroseparator, which may be used for cleaning or washing coal and separating it from refuse in general, irrespective of the size of the coal itself or of the refuse with which it is associated.

One of the objects of the invention is to provide automatic means for controlling the discharge of refuse. Another object is to provide means for controlling the discharge of refuse which is automatically responsive to the movement of the refuse itself. Other objects will appear from time to time in the specification and claims.

The invention is illustrated more or less diagrammatically in the accompanying drawings, in which—

Fig. 1 is a vertical cross section through a coal washing mechanism to which my invention may be applied;

Fig. 2 is a plan view of Fig. 1;

Fig. 3 is a detailed vertical cross section on an enlarged scale, showing the refuse discharge gate;

Like parts are indicated by like characters throughout the specification and drawings.

A is a water chamber into which water is discharged through a nozzle A¹ from a supply pipe A². Above the chamber A is a separating or cleaning chamber B. The two chambers are separated by a screen B¹. In the form herewith shown the screen is a perforated plate. Any separating parts might be used which would provide a surface across which material might slide and upon which material might be supported and which would also permit the passage of water through the partition.

B² indicates a chute along which material, such for example as coal, is discharged into the separating chamber.

B³ is a gate movably positioned to control the size of the opening through which material is discharged into the chamber B. B⁴ is a shaft fastened to the gate B³ and provided with a threaded upper end B⁵ upon which a hand wheel B⁶ is mounted for rota-

tion. By means of rotation of the hand wheel the gate may be lowered or raised.

C is a partition forming one side of the chamber B and over which the water which flows from the chamber A through the perforated plate B¹ and through the chamber B may be discharged along the passage C¹. In communication with the passage C¹ a discharge chute or conduit C² is preferably associated. The cleaned material, such as coal, which is carried by the upwardly moving current of water over the partition C and along the passage C¹, moves into the conduit C² from which it may be conveyed to any suitable place of disposal. Normally the coal and other cleaned material will be separated from the water during this passage.

D is a refuse chamber into which the refuse is discharged in the manner which will be described below and from which it is removed by a conveyor D¹ which may be of any suitable type but, as here shown, is a drag conveyor, composed of a chain with suitable drag flights which engage and drag or scrape up the refuse from the chamber. Located also within the chamber D is a float D². Extending upwardly from the float is a rod D³ which, at its upper end, is pivotally attached to a lever D⁴ which may carry a counterweight D⁵ and is pivotally mounted as at D⁶ on suitable support, which is itself carried on any suitable support. As here shown it is carried on a part of the cleaner housing. Depending downwardly from the opposite end of the lever D⁴ is a rod D⁷ which, by means of pivoted links D⁸, is connected to a hinged discharge lip D⁹, which is itself swingingly attached at the lower end of the perforated plate B¹ just below the discharge opening D¹⁰ in the partition C.

E is a gate mounted to be raised and lowered in the opening D¹⁰ and to control it. The gate may be manipulated to vary the size of the opening D¹⁰ or to close it entirely. E¹ is a rod extending upwardly from the gate, threaded at its upper end as at E² and having upon it a hand wheel E³. This wheel may be rotated to raise and lower the gate. E⁴ is a gate section hinged as at E⁵ to the gate E. Extending from it is a member E⁶

which is joined to an upwardly extending link E⁷. The link E⁷ is fastened at its upper end to a lever E⁸ which is itself at one end, as at E⁹, pivoted on any suitable support. At its opposite end the lever E⁸ is pivotally attached to an upward extension E¹⁰ of the rod D³.

The chute or trough C² has within it a perforated plate F, which is above its bottom and which in effect divides it into a coal or material chute above the perforated plate and a water conduit or trough below the plate. The water conduit communicates with a receiving tank F¹ which may be provided with a downwardly depending baffle F², a partition F³ and a conduit F⁴ by means of which water may be withdrawn from the tank F¹ by means of the centrifugal pump F⁵ which communicates with the conduit A² to which the nozzle A¹ is attached.

G is an extension from the chute C² along which coal or other material which has been cleaned may pass to any suitable discharge point. G¹ is a baffle located within the chute C², adapted to prevent, as far as possible, the passage of water along the chute beyond the baffle.

At various positions in the drawing coal particles are indicated by X and refuse particles by Y. They are initially introduced into the machine together and the separation occurs in the chamber B.

It will be understood that while I have described and shown a practical, operative device, nevertheless many changes might be made in the size, shape, number and disposition of parts, without departing from the spirit of my invention.

In the drawings, for the sake of clearness and to avoid confusion of lines, the perforated metal plates B¹ and F are shown in Figure 2 as screens. Of course, screens might be used instead of the plates, although plates will ordinarily be used.

In dealing with coal, the heavier material, slate, sulphur, bone coal etc., is the refuse. It is that material that I want to get rid of, but dealing with many other raw materials, it may be that the heavier parts are what I want to save. If, for instance, I am working with ores, frequently the values are heavy and the tailings are light. The majority of commercial use of my device is with coal, although it may be used in separating any kind of material and where I use the word refuse, I merely mean to refer to the heavier element of the physical mixture, if for coal, the refuse is thrown away, if for ore, the refuse is what I keep and the tailings or stone is thrown away.

A separating device such as mine depends for its operation on the presence of refuse. Some material must always pass out at the bottom of the refuse chamber. If there is no refuse present, that material will be coal.

If there is an adequate amount of refuse present, the refuse passes out and no coal comes out. This makes it especially important to be able to control with great accuracy the opening through which the refuse flows, because if I have a wide open door and there is not enough refuse to fill the door, coal goes out. If I have too narrow a door, refuse cannot get out and the system will be flooded with refuse. It becomes, therefore, necessary to have some measure of automatic control which will be directly responsive to the refuse and which will be sufficient to automatically maintain the refuse opening at the required size to seldom if ever let coal get out and at the same time to take care of and dispose of the continuously forming mass of refuse.

There is a limit beyond which it is not practically satisfactory to close the refuse gate. When very small quantities of refuse are present the opening of the gate may still be big enough so that the necessary bed of refuse would not be built up. Under these circumstances especially, it becomes of the utmost importance to have the lip co-operating with the gate so that while the gate may remain open enough to take care of a sudden influx of refuse material, the lip co-operating with it will maintain an adequate bed of refuse on the screen.

The gate automatically operates in response to variations in operating conditions, to variations in thickness of the refuse bed. Under this operation there is no manual control. The manual control of gate opening is for the purpose of initially setting the gate to take care of the particular size of material being handled. Once this initial manual adjustment is made, the apparatus thereafter automatically takes care of itself and it will be understood that this manual adjustment will be made for each particular size of material and thereafter, as long as material of that general size passes through the system, manual adjustment needs not to be varied.

In the claims, where I use the language coal cleaner, or coal separator or material cleaner, it will be understood that I am using this language merely as explanatory. The problem always present in the handling of bulk materials is to separate heavy from light. Perhaps the heavy is what is wanted, perhaps the light is what is wanted. It is usually thought of as a cleaning process. What is not wanted is cleaned out and taken away and it is this kind of separating or cleaning, as applied to coal or ore or any other fragmentary material to which my claims are directed and by heavy and light I am, of course, not referring to gross weight of particles of various sizes but to the specific gravity of the material.

The use and operation of my invention are as follows:

My invention, as herein applied, is associated with a hydroseparator, the operation of which is briefly as follows: water is forced into a separating chamber and by reason of the shape of the chamber it rises upwardly in it and overflows at one edge. Some of the water will also pass out of the chamber through an opening in its wall but there is always in the separating chamber a powerful upwardly rising water current. A mixed stream of material to be cleaned and refuse, such as coal for example, slate and other refuse, is discharged downwardly into and across the separating chamber and thus this stream of material encounters the upwardly rising water current. The refuse being heavier than the coal, it continues downwardly along the perforated plate and thus moves across the separating chamber. The coal, being lighter, is separated by the water from the refuse and rises upwardly with the rising water current. It is then carried over one wall of the separating chamber and is discharged from it with the water current which over flows the wall and continues into a discharge and separating chute. This chute is provided with a perforated partition by means of which the coal is dewatered and permitted to continue its movement outwardly to any suitable discharge. The water itself, as it leaves the coal, passes through the perforated partition in the coal chute and is gathered up and discharged into a receiving chamber from which it is withdrawn and again redischarged into the separating chamber.

The refuse, after it is separated from the coal in the separating chamber, moves downwardly and laterally across the separating chamber toward an opening in one of the walls of that chamber. This opening is provided with a gate which may be raised and lowered to any suitable adjusted position. A movably mounted discharge lip is hinged near the lower edge of the perforated plate which extends across and through the separating chamber and this lip is connected to a lever at the opposite end of which a float is provided. The position of the float is controlled by variations in the level of water in the refuse chamber. It has been found that in cleaning coal with a varying percentage of refuse, the level of the water in the refuse chamber rises and falls in response to variation in the amount of refuse at the bottom of the separating chamber. If a large amount of refuse is present with the coal as it is discharged into the separating chamber, the accumulation will be more rapid and the level of water in the refuse chamber will be higher. As the percentage of refuse coming in with the coal is decreased, the level of water in the refuse chamber lowers, as the

accumulation or concentration of refuse decreases. Since the hinged lip is connected to and movable by the float, which itself is positioned in the refuse chamber, a variation of the level of water in that chamber causes an automatic adjustment of the position of the hinged discharge lip. When operating under normal conditions and at a fixed capacity the float and the discharge lip stay approximately stationary and the refuse passes out from the separating chamber into the refuse chamber at a relatively constant rate. If the quantity of refuse increases or if for any reason an accumulation of refuse occurs at or near the discharge opening from the separating chamber, the level of the water in the refuse chamber rises, lifting the float and this movement of the float moves the hinged lip to permit more rapid discharge of material and thus, of course, to cause a more rapid rate of discharge of refuse. It has been found that sometimes disturbance in the rate of discharge is caused by the lodgment of one or more particles of refuse across the discharge opening. Such a particle of refuse is indicated by Z in Fig. 3. The presence of this particle will tend to cause disturbance of the rate of discharge of refuse from the separating chamber with the consequent rise of level of water in the refuse chamber. As the float raises or lowers the hinged discharge lip, the lever E⁸ is raised and raises the link E⁷, thus causing the section E⁴ to swing backward into the dotted line position of Fig. 3 and thus additionally the opening for the discharge of refuse from the separating chamber is increased since the raising of the float opens the gate and also moves the discharge lip to a wider open position. Both of these movements occur as a result of the rise of level of the water in the refuse chamber. As soon as the discharge of refuse from the separating chamber again assumes a normal rate, the level of the water in the refuse chamber tends to lower, the gate is again partially closed and the discharge lip raised. Thus the mechanism shown herewith automatically and positively adapts itself to variations in the quality of material and the rate of feed of material and adjustments, therefore, need not be made by an operator, the machine being entirely automatic in its operation.

In general, as refuse accumulates on the plate or screen between the separating chamber and the water chamber, the flow of water through the screen is resisted and a differential pressure builds up. This differential expresses itself in a flow of water into the float chamber and thus as the refuse accumulates on the screen, the water level in the float chamber, because of the increased resistance by the refuse, rises to raise the float and thereby permit an easier escape of refuse.

I claim:

1. In a hydraulic coal cleaner, a pair of chambers, normally water filled, a partition separating them, said partition having an opening, a gate and a discharge lip controlling discharge through said opening and automatic means for varying the position of said gate and said discharge lip in response to variations in the movement of refuse through said opening.

2. In combination in a hydraulic material separating machine, a separating chamber, means for feeding material to said chamber, means for discharging upwardly through said chamber a rising current of water, whereby the lighter material is raised from the heavier material, a refuse chamber, a partition between the two chambers having an opening, a gate adapted to control said opening, a discharge lip beyond said opening and within the refuse chamber, a float adapted to rise and fall in response to variations in the level of the water, connections between said float, said lip and said gate, whereby the lip and gate are automatically moved in response to the water level variations to vary the size of the discharge opening.

3. In combination in a hydraulic material separating machine, a separating chamber, means for feeding material to said chamber, means for discharging upwardly through said chamber a rising current of water, whereby the lighter material is raised from the heavier material, a refuse chamber, a partition between the two chambers having an opening, a gate adapted to control said opening, a discharge lip beyond said opening and within the refuse chamber, a float within the refuse chamber and adapted to rise and fall in response to variations in the level of the water within the said chamber, connections between said float, said lip and said gate, whereby the lip and gate are automatically moved in response to the water level variations to vary the size of the discharge opening.

Signed at Matoaka, county of Mercer, and State of West Virginia, this 15th day of November, 1929

EARL STUMP.

50

55

60

65