

(12) UK Patent Application (19) GB (11) 2 143 449 A

(43) Application published 13 Feb 1985

(21) Application No 8413028

(22) Date of filing 22 May 1984

(30) Priority data

(31) 3320075 (32) 3 Jun 1983 (33) DE

(71) Applicant

Drester AB (Sweden),
Box 106, S-240 17 Sondra Sandby, Sweden

(72) Inventor

Leif Stern

(74) Agent and/or Address for Service

Stevens Hewlett & Perkins,
5 Quality Court, Chancery Lane, London WC2A 1HZ

(51) INT CL³

B24C 5/02 7/00 // 5/04

(52) Domestic classification

B3D 8A1

(56) Documents cited

GB A 2116637 GB 1591456 GB 1403528
GB A 2116293 GB 1503658 GB 1393560
GB A 2026359 GB 1424896

(58) Field of search

B2F
F2V

(54) Abrasive blast apparatus

(57) A blast gun in which blast material e.g. blasting sand is passed through an injection pipe 2 into a blast nozzle 1, blast air is led into the blast nozzle through an air supply gap 3 between the injector pipe 2 and the blast nozzle 1, and a valve mechanism 14 is adapted to control the blast air supply to the blast nozzle 1.

In order to keep the air supply gap 3 unobstructed so that this gap will not be clogged by material supplied to the blast gun when the air supply ceases at least one air passage 26 is provided which, when the valve mechanism 14 is closed, allows blast air to pass to the air supply gap 3 for the purpose of keeping the gap clean.

Fig. 1

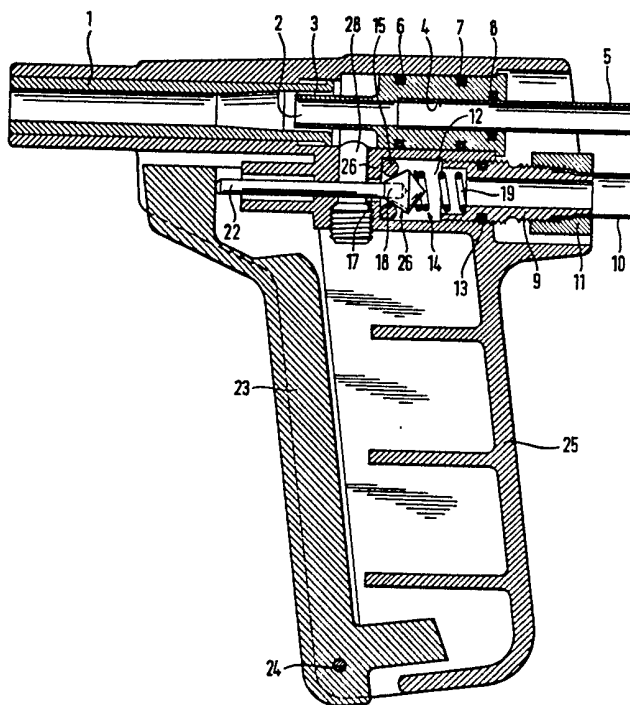

GB 2 143 449 A

Fig. 1

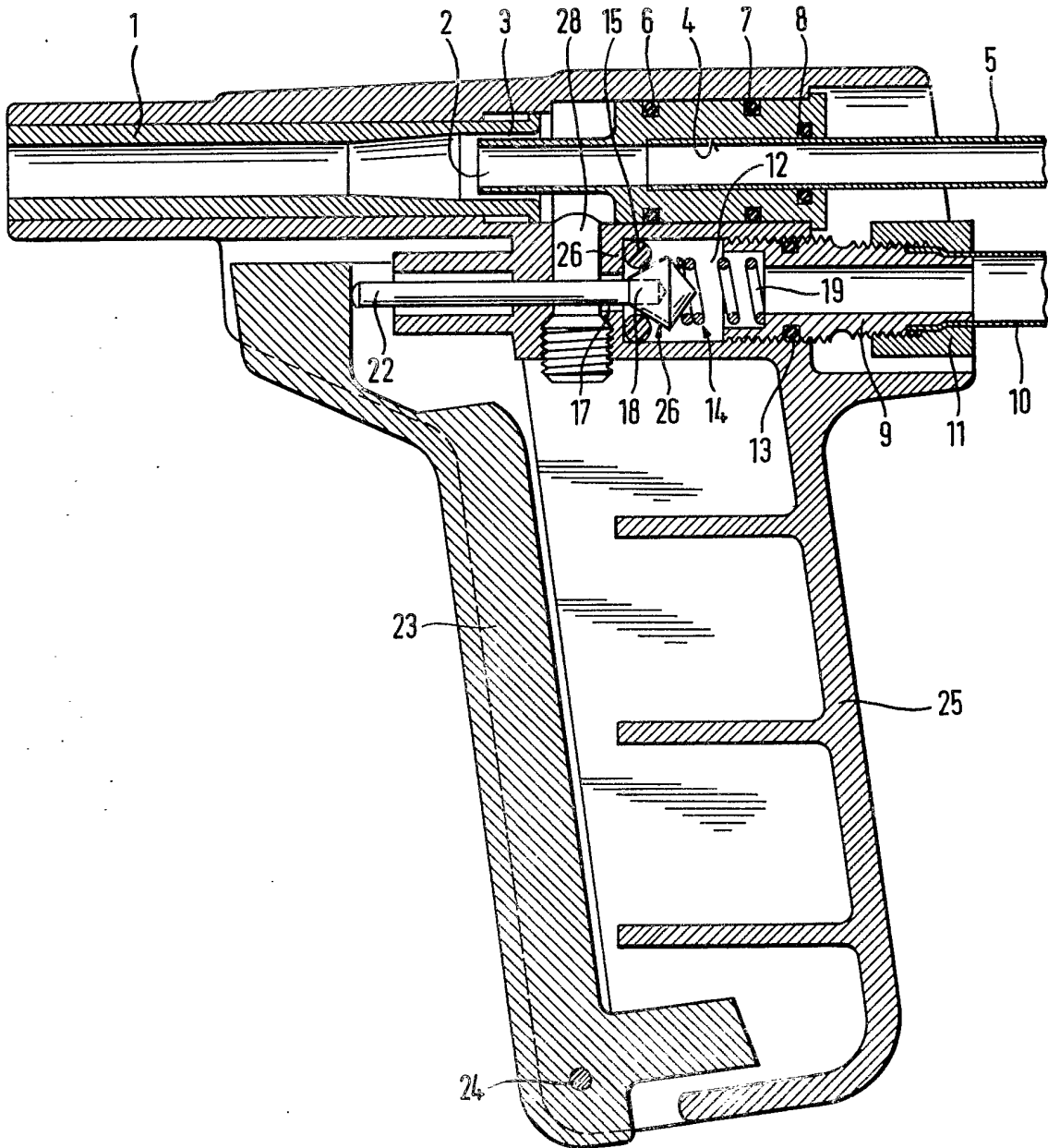

Fig:2

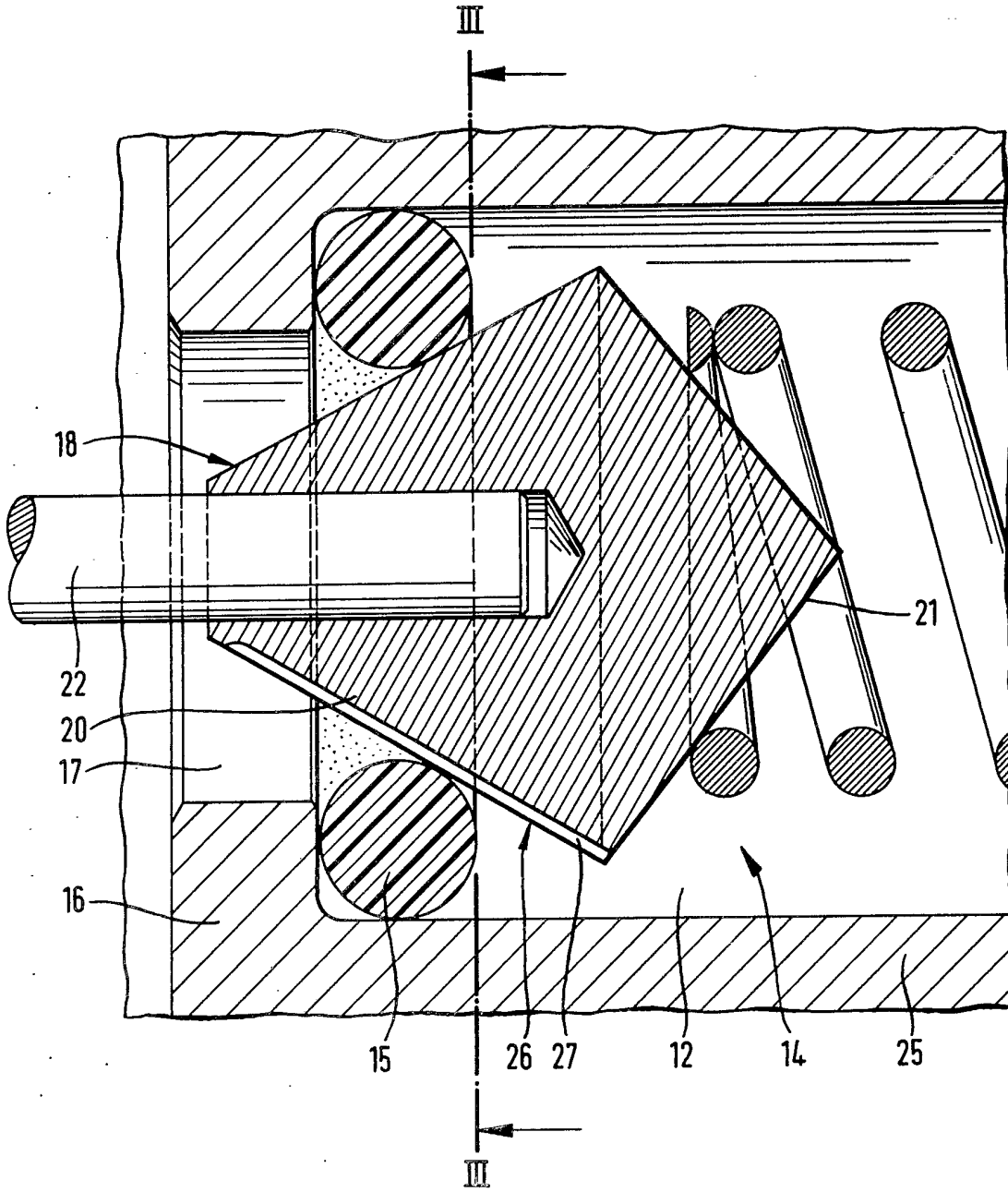
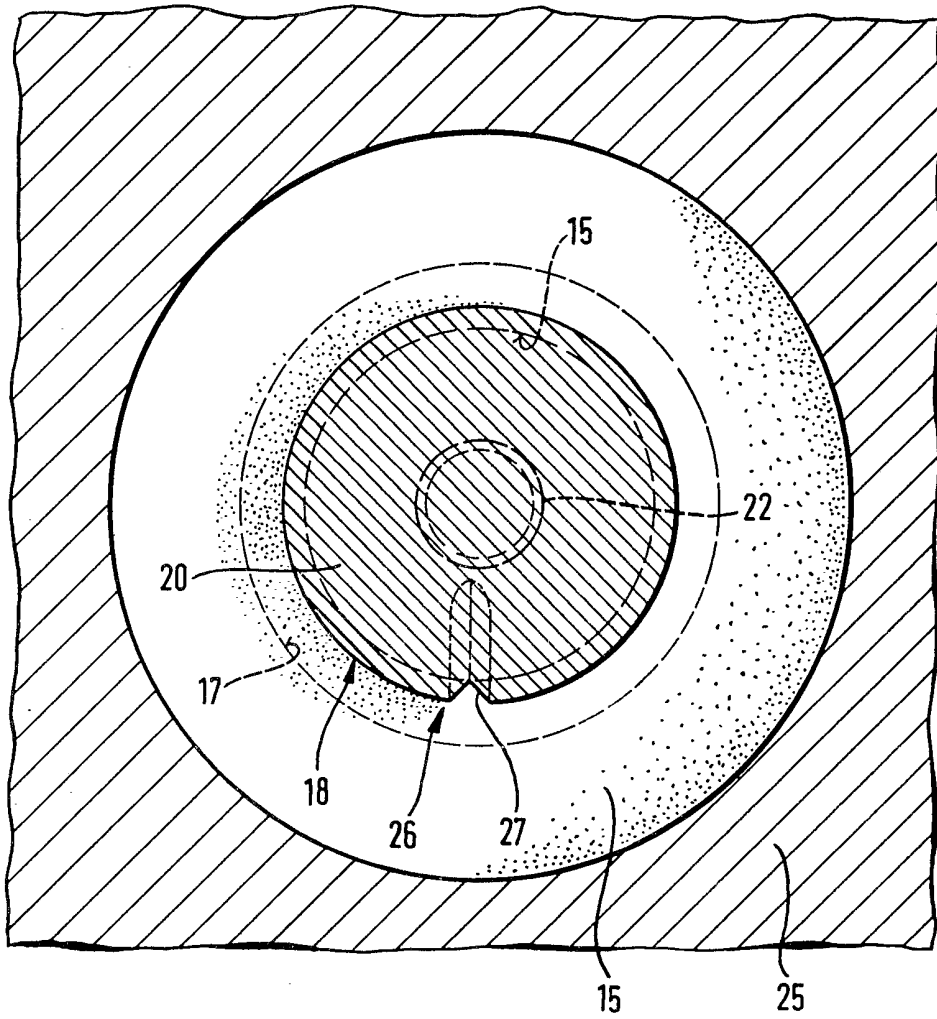

Fig. 3



SPECIFICATION

Blast apparatus

5 This invention relates to blast apparatus in which blast material is passed through an injector pipe into a blast nozzle, blast air is led into the blast nozzle through an air supply gap between the injector pipe and the blast nozzle, and a valve mechanism is adapted to control the blast air supply to the blast nozzle.

10 In such a blast apparatus it is advantageous to make the air supply gap as narrow as possible in order to accelerate the blast air jet. However, blast material will deposit in narrow air supply gaps as soon as the air supply ceases. As a result, the air supply gap will be obstructed after a short time so that the function of the blast apparatus is impaired.

20 The object of the present invention is to overcome this drawback and to achieve that the air supply gap cannot be obstructed by blast material. The present invention accordingly provides a blast apparatus comprising an injector pipe for conducting blast material to a blast nozzle, a blast air supply gap between the injector pipe and the blast nozzle, a valve mechanism adapted to control the delivery of blast air to the blast nozzle, and at least one air passage which, when the valve mechanism is closed, allows blast air to pass to the air supply gap for the purpose of keeping said gap unobstructed.

35 The invention will now be described more in detail with reference to the accompanying drawings in which:—

Figure 1 is a section of a blast apparatus according to the invention;

40 *Figure 2* is a section of a valve mechanism of the blast apparatus; and

Figure 3 is a section on line III—III in Fig. 2.

The blast apparatus illustrated is designed as a blast gun. A blast nozzle 1 is disposed in the upper part of the gun and the front end of an injector pipe 2 projects into the rear end of the blast nozzle 1. The injector pipe 2 is coaxial with the blast nozzle 1, and the outer diameter of the injector pipe 2 is somewhat smaller than the inner diameter of the blast nozzle 1 whereby a narrow air supply gap 3 is formed between the blast nozzle 1 and the injector pipe 2, said gap thus extending around the injector pipe. The rear part of the injector pipe 2 has a socket 4 which is adapted to accommodate a material supply conduit 5 and is coaxial with the front part of the injector pipe 2. The injector pipe 2 is tight with respect to the interior of the gun by means of sealing rings 6, 7 and the material supply conduit 5 projects into the injector pipe 2 through a sealing ring 8. The material supply conduit 5 is connected to a blasting sand container (not shown) or to a container for other material to be projected.

65 In the embodiment described an air supply

device is contained in the blast gun. This device comprises a connection pipe 9 parallel to the socket 4 and the rear of the gun and to the rear end of which an air supply conduit 10 is connected and retained by a nut 11. The air supply conduit 10 is connected to a source of compressed air (not shown) and the connection pipe 9 is screwed into a valve chamber 12 and sealed with respect thereto by means of a sealing ring 13. The valve chamber 12 contains a valve mechanism 14 which has a seat 15 in the form of a ring of elastic material which is applied against a front wall 16 of the valve chamber 12 and surrounds an opening 17 in said front wall 16. A movable valve member 18 is urged by a spring 19 against the valve seat 15. The valve member 18 has a conical front portion 20 which engages the valve seat 15, and a conical rear portion 21 against which the spring 19 bears. The valve member 18 is provided with an operating rod 22 which projects through the opening 17 and can be actuated by means of a trigger 23 pivotally mounted on a pin 24 at the lower end of a grip 25. Upon actuation of the trigger 23 the valve member 18 is moved away from the seat 15 against the pressure of the spring 19 and the compressed air can pass through the opening 17 and an outwardly closed passage 28 into the air supply gap 3 and delivered into the blast nozzle around the injector pipe 2. By the injector action of the compressed air supplied in this way to the blast nozzle 1, the blast material will be supplied to the blast nozzle 1 and hurled out of it.

As the air supply gap 3 is very narrow for the purpose of attaining a high air velocity, the blast material will deposit in and clog the air supply gap 3 as soon as the valve mechanism 14 closes. To overcome this drawback the valve mechanism 14 has at least one air passage 26 which, when valve mechanism 14 is closed, allows sufficient air to pass to the air supply gap 3 to prevent blast material from depositing in and clogging said gap.

In the embodiment illustrated, said air passage 26 is in the form of an elongate recess 27 which is arranged in the surface of the conical front part 20 and extends beyond the valve seat 15, thus allowing air to pass, when the valve mechanism 14 is closed, in order to maintain the air supply gap 3 unobstructed.

This design of the air passage 26 is simple and will, when valve mechanism 14 is open, be kept clean by the compressed air in case any matter should tend to clog the air passage 26. Said cleaning procedure will be facilitated in that the air passage 26 is in the form of a surface recess 27.

The important thing is when valve mechanism 14 is closed, to enable compressed air to flow past the valve mechanism 14 for fushing of the air supply gap 3. This can be achieved by means of a great many other

constructions. For instance, several recesses 27 may be provided in the valve member 18; the air passage 26 may be formed by one or more bores in the valve member 18 or by one
5 or more bores or passages disposed at other points. Also the blast apparatus as a whole may be given shape other than that of a gun, although the embodiment described and shown is a particularly simple and functionally
10 reliable blast apparatus construction.

CLAIMS

1. A blast apparatus comprising an injector pipe for conducting blast material to a
15 blast nozzle, a blast air supply gap between the injector pipe and the blast nozzle, a valve mechanism adapted to control the delivery of blast air to the blast nozzle, and at least one air passage which, when the valve mechanism
20 is closed, allows blast air to pass to the air supply gap for the purpose of keeping said gap unobstructed.
2. Apparatus as claimed in Claim 1, wherein the air passage is provided in a part
25 of the valve mechanism.
3. Apparatus as claimed in Claim 2, wherein the air passage is a recess in the surface of a valve member of the valve
30 mechanism.
4. Apparatus as claimed in Claim 3, wherein the recess is formed in a conical front portion of the valve member, said conical front portion projecting into a valve seat.
5. Apparatus as claimed in any one of
35 Claims 1 to 4, wherein the air supply gap is formed by a part of the injector pipe that projects coaxially into the blast nozzle.
6. Apparatus as claimed in Claim 5, wherein the injector pipe has a coaxially extending socket for the connection of a material supply conduit thereto.
7. Apparatus as claimed in Claim 6,
40 wherein the injector pipe and the blast nozzle are built into a blast gun and the valve
45 mechanism is built into a gun grip and actuated by means of a trigger at the gun grip.
8. Apparatus as claimed in Claim 7, including a connection socket for a material supply conduit and a connection pipe for the
50 blast air disposed below one another at the rear of the gun and are parallel.
9. A blasting gun substantially as hereinbefore described with reference to the accompanying drawings.