

Aug. 19, 1947.

E. R. GILLESPIE

2,425,797

HEATING SYSTEM

Filed Dec. 29, 1945

2 Sheets-Sheet 1

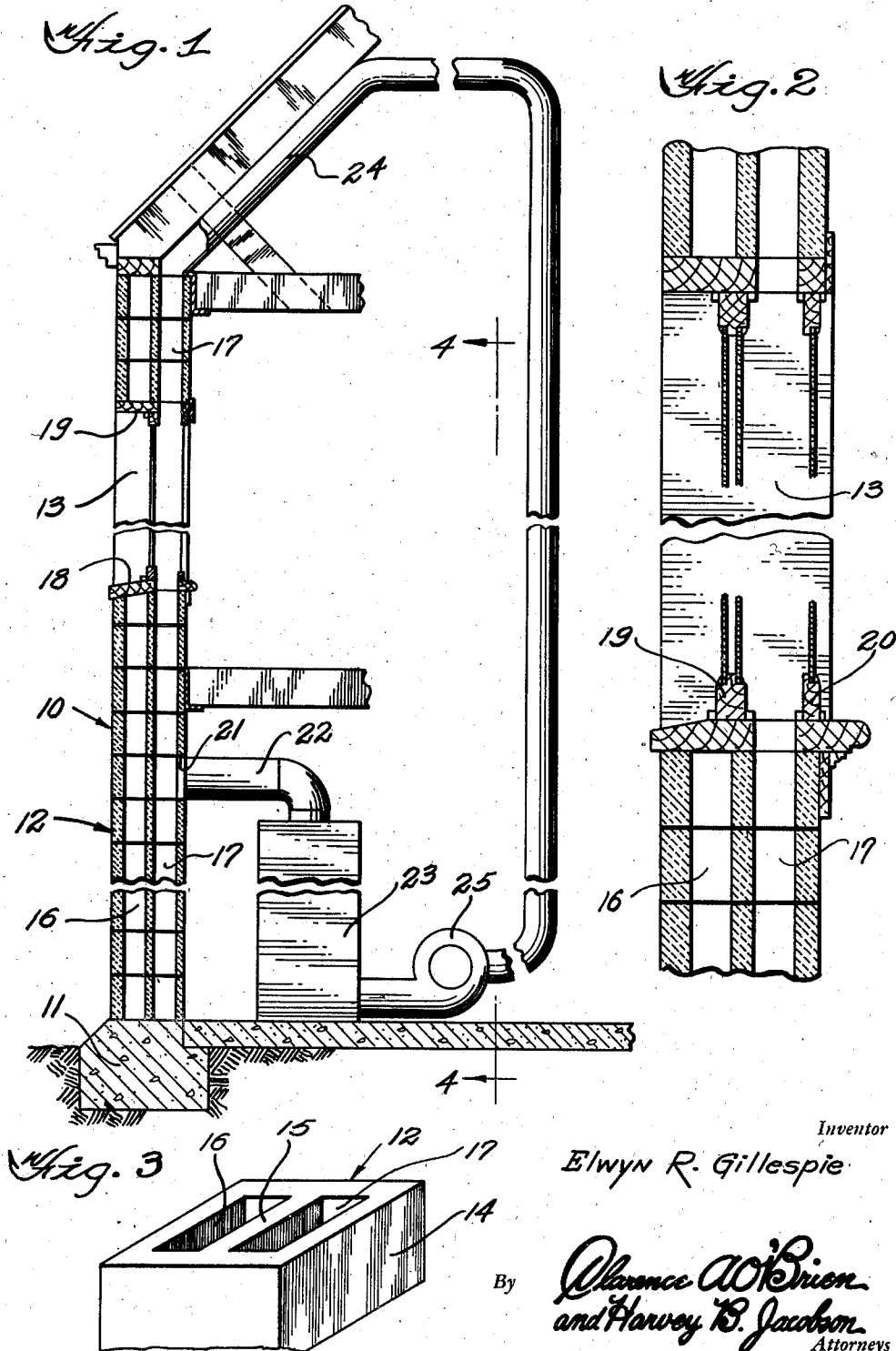

Inventor

Elwyn R. Gillespie

By

Clarence W. O'Brien  
and Harvey B. Jacobson  
Attorneys

Aug. 19, 1947.

E. R. GILLESPIE

2,425,797

HEATING SYSTEM

Filed Dec. 29, 1945

2 Sheets-Sheet 2

*Fig. 4*

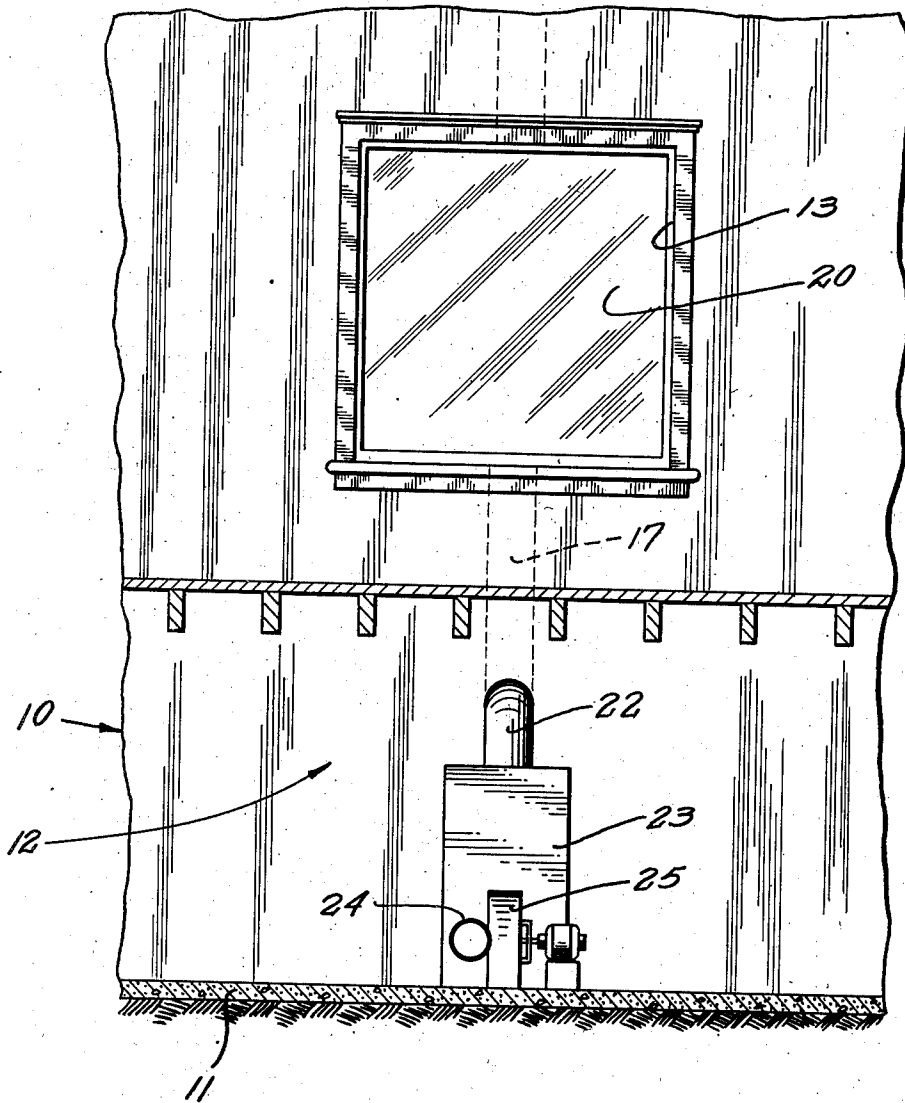

Inventor

*Elwyn R. Gillespie*

By

*Clarence A. O'Brien*  
*and Harvey B. Jackson*  
Attorneys

# UNITED STATES PATENT OFFICE

2,425,797

## HEATING SYSTEM

Elwyn R. Gillespie, Richmond, Calif.

Application December 29, 1945, Serial No. 638,250

1 Claim. (Cl. 237—50)

1

This invention relates to a heating system and more particularly to a heating system for buildings such as dwellings, office buildings and the like.

The primary object of the invention is the efficient heating of a given space without the use of visible air ducts.

Another object is to utilize the wall of a building as a heated air duct and to employ the window space normally provided in a building as the heat radiating area.

The above and other objects may be attained by employing this invention which embodies among its features a heat exchange unit connected to discharge heated air into an air duct built into the wall of a building, which air duct opens into the lower end of a window space into which the heated air is discharged for radiation into the space to be heated, a double glazed sash closing the outer side of the window space to conserve the heat, a single glazed sash closing the inner side of the window space, a return duct leading from the window space back to the heat exchange unit and circulating means in the system for creating a sub-atmospheric pressure in the return duct behind the heat exchange unit.

Other features include a building block so constructed as to form an air space between an intermediate wall and the outside face of the block, and an air duct between the intermediate wall and the inner face of the block by the use of which block concealed air ducts may be built into a wall.

In the drawings:

Figure 1 is a sectional view through a building showing this improved heating system installed therein,

Figure 2 is an enlarged sectional view through the walls of building showing in detail the window space and the manner in which it is glazed,

Figure 3 is a perspective view of a building block employed in building a wall suitable for the installation of this heating system, and

Figure 4 is a vertical sectional view taken substantially on the line 4—4 of Figure 1.

Referring to the drawings in detail a building designated generally 10 is provided with the usual footings 11 upon which my improved building unit designated generally 12 are laid one upon the other to form a wall having a window opening 13 intermediate its upper and lower ends.

The building unit 12 above comprises a hollow rectangular body 14 between opposite ends of which extends a longitudinal partition wall 15 dividing the block 14 into two separate chambers 16 and 17 respectively. The chambers 16 are

2

arranged adjacent the outer face of the block to form in the wall an insulating air space closed at its upper end by a window sill 18 arranged at the lower end of the window space 13 and the lower end of the upper insulating space above the window space 13 is closed by the window lintel 19. The chambers 17 in the blocks 14 align to form a vertically extending air duct the upper end of which opens into the window space 13 for the introduction of heated air into the window space as will be more fully hereinafter explained. The blocks above the window space have their chambers 17 aligned and communicate through a suitable opening in the lintel 19 with the window space 13 and form a part of the return duct as will be more fully hereinafter explained.

The portion of the window opening 13 which faces the exterior of the building is closed by a double glazed sash 19 and the back portion of the window space 13 opening toward the interior of the building is closed by a single glazed sash 20 and the duct formed by the chamber 17 of the blocks 12 opens into the chamber thus formed between the sash as will be readily understood as upon reference to the drawings.

Connected through a suitable port 21 formed in one of the lower blocks in the wall opening into the chamber 17 in said block is a warm air duct 22 connected to the discharge end of a suitable heat exchange unit 23. A return duct 24 leads from the duct formed by the chambers 17 in the blocks above the lintel of the window face 13 and thence leads downwardly to enter the heat exchange unit 23 at its intake side. In order to establish circulation through the system a suitable suction fan 25 is interposed in the return duct 24 between the end connected to the duct formed by the blocks 14 above the window and the intake opening of the heat exchange unit 23, preferably adjacent the heat exchange unit as illustrated.

In operation it will be understood that the heat exchange unit 23 receives cooled air through the return duct 24 and suction fan 25 and through the contact of the air with the heat exchange unit warm air is discharged through the pipe 22 into the duct formed in the walls of the building by the chambers 17 in the blocks from whence it flows upwardly into the space between the double glazed sash and single glazed sash of the window opening 13 the heat is then radiated through the single glazed sash 20 into the space to be heated and the cool air is drawn upwardly through the return duct 24 and back to the suc-

3

tion fan 25 where it is discharged again into the heat exchange unit 23 for reheating.

By the use of a closed system of this nature the air employed for carrying the heat to the desired points of distribution is in no way effected by changes of temperature or humidity of the surrounding atmosphere and a negative pressure is maintained through the greater part of the system by the use of the suction fan 25.

Obviously the heat exchange unit 23 may take the form of a cooling unit in which event cooled air will be circulated through the system for the purpose of absorbing heat from the space in which the temperature is to be controlled. Due to the dead air space contained within the double glazed sash 19 heat loss through the window to the exterior of the building will be avoided.

While in the foregoing there has been shown and described the preferred embodiment of this invention it is to be understood that minor changes in the details of construction, combination and arrangement of parts may be resorted to without departing from the spirit and scope of the invention as claimed.

I claim:

In a closed heating system in combination with a heat exchange unit a building wall having a window space and an air duct therein opening

4

into the bottom and top of the window space, a double glazed sash closing the window space facing the outside of the wall, a single glazed sash closing the window space adjacent the inside of the wall, said sash forming a chamber between them into the lower end of which warm air is fed through said air duct from said heat exchange unit, and a conduit establishing connection between the air duct opening into the upper end of the chamber and the cold air intake side of the heat exchange unit and a suction fan in the system adjacent the heat exchange unit to maintain a forced circulation of air at sub-atmospheric pressure through the system.

ELWYN R. GILLESPIE.

#### REFERENCES CITED

The following references are of record in the file of this patent:

#### UNITED STATES PATENTS

Number	Name	Date
2,240,951	Hamjy -----	May 6, 1941
1,467,005	Lawrence -----	Sept. 4, 1923
676,296	Allison -----	June 11, 1901
2,107,523	Coe -----	Feb. 8, 1938