

(19) World Intellectual Property
Organization
International Bureau



(43) International Publication Date
18 August 2005 (18.08.2005)

PCT

(10) International Publication Number
WO 2005/074680 A1

(51) International Patent Classification⁷: A01M 23/30,
23/00, 23/24

(74) Agent: POWELL FORMAN KELLY LLP; Oriel Cham-
bers, 14 Water Street, Liverpool L2 8TD (GB).

(21) International Application Number:
PCT/GB2005/000417

(81) Designated States (unless otherwise indicated, for every
kind of national protection available): AE, AG, AL, AM,
AT, AU, AZ, BA, BB, BG, BR, BW, BY, BZ, CA, CH, CN,
CO, CR, CU, CZ, DE, DK, DM, DZ, EC, EE, EG, ES, FI,
GB, GD, GE, GH, GM, HR, HU, ID, IL, IN, IS, JP, KE,
KG, KP, KR, KZ, LC, LK, LR, LS, LT, LU, LV, MA, MD,
MG, MK, MN, MW, MX, MZ, NA, NI, NO, NZ, OM, PG,
PH, PL, PT, RO, RU, SC, SD, SE, SG, SK, SL, SY, TJ, TM,
TN, TR, TT, TZ, UA, UG, US, UZ, VC, VN, YU, ZA, ZM,
ZW.

(22) International Filing Date: 7 February 2005 (07.02.2005)

(25) Filing Language: English

(26) Publication Language: English

(30) Priority Data:
0402717.3 5 February 2004 (05.02.2004) GB

(84) Designated States (unless otherwise indicated, for every
kind of regional protection available): ARIPO (BW, GH,
GM, KE, LS, MW, MZ, NA, SD, SL, SZ, TZ, UG, ZM,
ZW), Eurasian (AM, AZ, BY, KG, KZ, MD, RU, TJ, TM),
European (AT, BE, BG, CH, CY, CZ, DE, DK, EE, ES, FI,
FR, GB, GR, HU, IE, IS, IT, LT, LU, MC, NL, PL, PT, RO,
SE, SI, SK, TR), OAPI (BF, BJ, CF, CG, CI, CM, GA, GN,
GQ, GW, ML, MR, NE, SN, TD, TG).

(71) Applicant (for all designated States except US): NET-
WORK PEST CONTROL SYSTEMS LIMITED
[GB/GB]; 1030 Centre Park, Slutchers Lane, Warrington
WA1 1QR (GB).

(72) Inventor; and

(75) Inventor/Applicant (for US only): KNIGHT, Peter
[GB/GB]; 1030 Centre Park, Slutchers Lane, Warrington
WA1 1QR (GB).

Declaration under Rule 4.17:

— of inventorship (Rule 4.17(iv)) for US only

[Continued on next page]

(54) Title: PEST CONTROL APPARATUS

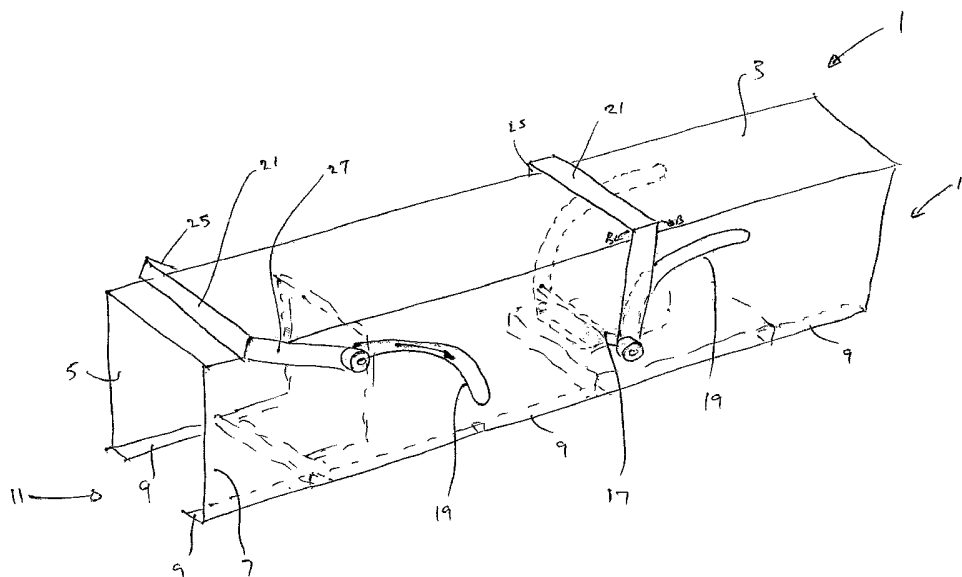

(57) Abstract: Pest control apparatus for trapping rodents such as rats and mice is disclosed. The apparatus comprises a housing (1) enclosing a rodent reception space and at least one opening (11,13) for entry of a rodent into the reception space. Within the rodent reception space, there is at least one trap of a type that requires to be set, usually against spring bias. The apparatus includes setting means (17,21) co-operable with the trap for setting it and the setting means is operable from a position external to the rodent reception space.

WO 2005/074680 A1



Published:

- *with international search report*
- *before the expiration of the time limit for amending the claims and to be republished in the event of receipt of amendments*

For two-letter codes and other abbreviations, refer to the "Guidance Notes on Codes and Abbreviations" appearing at the beginning of each regular issue of the PCT Gazette.

Pest Control Apparatus

The present invention relates to pest control apparatus for trapping rodents especially
5 rats and mice.

A known pest control apparatus comprises a hollow elongate channel member, open at
opposite ends and having a removable top cover affording access to a rodent trap for the
purpose of setting the trap and releasing any trapped rodents caught in the trap.

Because the trap is enclosed within the channel member, it is not possible to tell
10 whether it has been triggered without removing the cover. Furthermore, for certain
types of sensitive traps, subsequent fitting of the cover after setting of the trap can
trigger the trap necessitating a repeating of the process until the trap is successfully set
and the cover replaced without triggering the trap.

The present invention aims to provide an improved pest control apparatus.

15 Accordingly, the present invention provides a pest control apparatus for trapping
rodents and comprises a housing enclosing a rodent reception space and having at least
one opening for entry of a rodent into the reception space and having within the rodent
reception space at least one trap of a type that requires to be set, usually against spring
bias, and characterised by setting means co-operable with the trap for setting it and by
20 the setting means being operable from a position external to the rodent reception space.

More particularly the setting means may be moveable between a trap-released position
and a trap-set position and *vice versa* whereby from an external visual inspection of the
position of the setting means it is possible to determine whether the trap is set or un-set.
To that end, the setting means is acted on by the trap to move it to the trap-released
25 position when the trap is triggered.

Conveniently, the housing is an elongated channel and the opening is in one end.
Preferably there is an opening in the opposite ends of the channel. Conveniently, the
housing comprises an inverted, rectangular-section channel member having a top and

depending side walls. Conveniently, the side walls have turned-in portions to provide ground-supporting flanges. Conveniently, the trap is mounted spanning the walls or supported on said turned portions. Preferably the housing accommodates two traps mounted in-line, one after the other, and positioned as a mirror image: that is, with the lead-in ramp facing respective end openings of the housing. Conveniently, a respective setting means is provided for each trap.

More particularly, the setting means may comprise a transverse bar extending across the channel, the opposite ends of which are received in a respective slot in the side walls. Conveniently, the slot is curved and, for example, extends from a position adjacent to the top to a position remote from said top, maybe firstly with a gradual incline and then with a sharper radius. In use, the transverse bar typically co-operates with a setting mechanism of the trap. Connected to the transverse bar is an operating lever which is, for example, generally of an inverted U-shape. The transverse bar is positioned in the slot adjacent to the top when the trap is un-set, and remote from the top when the trap is set. In the set position the bar is moveable along part of the slot.

An embodiment of the present invention will now be described in detail by way of example only, with reference to the accompanying drawings, which:

Figure 1 is a partially broken-away perspective view of apparatus embodying the invention.

Pest control apparatus embodying the invention comprises a channel member 1 having a top 3, two downwardly depending side walls 5,7 having three lower in-turned flange portions 9 along each bottom edge of the side wall. The opposite ends 11,13 of the channel 1 are sufficiently open to admit a rodent of the type for which the trap is designed. In use the channel is placed on the ground or other support surface. The position is chosen that is most likely to be part of a rat run. The pest control device is intended for catching the likes of rats and mice. It could be used for other rodents if suitably sized up.

In the illustrated embodiment the channel is adapted to receive two proprietary mouse traps of the type that require setting and comprise a base plate, a trigger plate and a stun bar/actuating bar. Other types of trap may be employed and devices could include a

purpose-designed trap as opposed to receiving a proprietary trap as a complete but separate unit mounted therein.

In the illustrated embodiment, the two traps are orientated in opposite directions so that the trigger plate/entrance ramp to the trap is adjacent to the respective open ends of the channel. By this means, a rodent entering the channel from either end is likely to trigger one or other of the traps.

In order to facilitate setting of the respective traps, a setting means is provided for each trap and this comprises a transverse bar 17 whose opposite ends are guided for movement in a slot 19 in each of the walls 5,7. The slot is arcuate and extends from a position adjacent to the top 3 to a position remote from it and adjacent to the lower edge of the side walls 5,7. The transverse bar connects with an actuating member 21 comprising a transverse element 23 and two legs 25,27 connected at one end to opposite ends of the transverse element and whose other ends connect with the ends of the transverse bar 17. The actuating element is disposed externally of the channel member and the transverse bar is positioned for co-operating engagement with the setting mechanism of the trap contained within the channel. Thus pushing on the actuating element causes the trap to be set as the transverse bar moves along the slot 19 as represented by Arrow A. In the set position the transverse element sits adjacent to the top with only limited movement available as represented by Arrows B,B.

It will be seen from the illustration that by simply observing the position of the actuating member, more particularly the position of the transverse bar 17, it is possible to determine whether the trap is set and/or whether it has been triggered since the actuating element is displaced from the set position shown in the right-hand side of the illustration to the un-set position as shown in the left hand side of the illustration when the trap is triggered.

Claims

- 5 1. Pest control apparatus for trapping rodents and comprises a housing enclosing a rodent reception space and having at least one opening for entry of a rodent into the reception space and having within the rodent reception space at least one trap of a type that requires to be set, usually against spring bias, and characterised by setting means co-operable with the trap for setting it and by the setting means being operable from a position external to the rodent reception space.
- 10 2. Pest control apparatus according to claim 1 in which the setting means is moveable between a trap-released position and a trap-set position and *vice versa* whereby from an external visual inspection of the position of the setting means it is possible to determine whether the trap is set or un-set.
- 15 3. Pest control apparatus according to claim 2 in which the setting means is acted on by the trap to move it to the trap-released position when the trap is triggered.
4. Pest control apparatus according to any preceding claim in which the housing is an elongate channel and the opening is in one end.
5. Pest control apparatus according to claim 4 in which there is a respective opening in the opposite ends of the channel.
- 20 6. Pest control apparatus according to any preceding claim in which the housing comprises an inverted, rectangular-section channel member having a top and depending side walls.
7. Pest control apparatus according to claim 6 in which the side walls have turned-in portions to provide ground-supporting flanges.
- 25 8. Pest control apparatus according to claim 7 in which the trap is mounted spanning the walls or supported on said turned-in portions.

9. Pest control apparatus according to any preceding claim in which the housing accommodates two traps mounted in-line and positioned with a lead-in ramp facing respective end openings of the housing.
- 5 10. Pest control apparatus according to any preceding claim in which a respective setting means is provided for each trap.
11. Pest control apparatus according to any preceding claim in which the setting means comprises a transverse bar extending across the channel, the opposite ends of which are received in a respective slot in the side walls.
- 10 12. Pest control apparatus according to claim 11 in which the slot is curved and extends from a position adjacent to the top to a position remote from the top, firstly with a gradual incline and then with a sharper radius.
13. Pest control apparatus according to claim 11 or claim 12 in which, in use the transverse bar co-operates with a setting mechanism of the trap.
- 15 14. Pest control apparatus according to any one of claims 11 to 13, there being connected to the transverse bar an operating lever which is generally of an inverted U-shape.
15. Pest control apparatus according to any one of claims 11 to 14 in which the transverse bar is positioned in the slot adjacent to the top when the trap is un-set, and remote from the top when the trap is set.
- 20 16. Pest control apparatus according to claim 15 in which, in the set position, the bar is moveable along part of the slot.

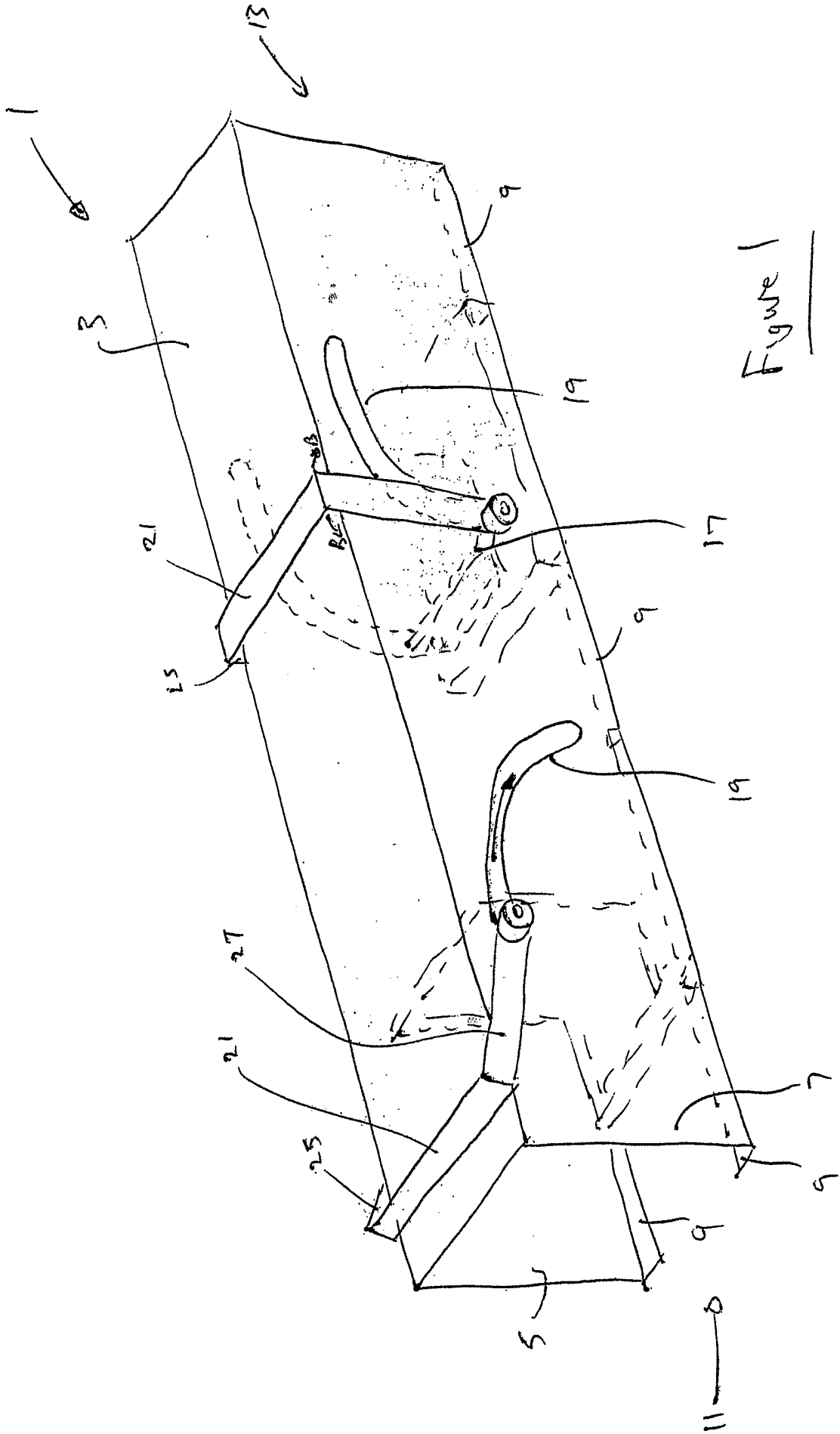

INTERNATIONAL SEARCH REPORT

International Application No
 /GB2005/000417

A. CLASSIFICATION OF SUBJECT MATTER
 IPC 7 A01M23/30 A01M23/00 A01M23/24

According to International Patent Classification (IPC) or to both national classification and IPC

B. FIELDS SEARCHED

Minimum documentation searched (classification system followed by classification symbols)
 IPC 7 A01M

Documentation searched other than minimum documentation to the extent that such documents are included in the fields searched

Electronic data base consulted during the international search (name of data base and, where practical, search terms used)

EPO-Internal, WPI Data, PAJ

C. DOCUMENTS CONSIDERED TO BE RELEVANT

Category °	Citation of document, with indication, where appropriate, of the relevant passages	Relevant to claim No.
X	GB 2 332 356 A (* INDUSTRIAL AND DOMESTIC PEST CONTROL PRODUCTS LIMITED) 23 June 1999 (1999-06-23) page 2 - page 5; figures 3,4	1-8, 10-14
Y	-----	9
X	US 4 306 370 A (LINDBLAD ET AL) 22 December 1981 (1981-12-22) abstract; figures 1-5	1-4, 10
X	US 5 172 512 A (BODKER ET AL) 22 December 1992 (1992-12-22) abstract; figures 1-9	1-4, 6, 10
X	US 5 148 624 A (SCHMIDT ET AL) 22 September 1992 (1992-09-22) abstract; figures 1-8	1-4, 10
	----- -/--	

Further documents are listed in the continuation of box C.

Patent family members are listed in annex.

° Special categories of cited documents :

- *A* document defining the general state of the art which is not considered to be of particular relevance
- *E* earlier document but published on or after the international filing date
- *L* document which may throw doubts on priority claim(s) or which is cited to establish the publication date of another citation or other special reason (as specified)
- *O* document referring to an oral disclosure, use, exhibition or other means
- *P* document published prior to the international filing date but later than the priority date claimed

- *T* later document published after the international filing date or priority date and not in conflict with the application but cited to understand the principle or theory underlying the invention
- *X* document of particular relevance; the claimed invention cannot be considered novel or cannot be considered to involve an inventive step when the document is taken alone
- *Y* document of particular relevance; the claimed invention cannot be considered to involve an inventive step when the document is combined with one or more other such documents, such combination being obvious to a person skilled in the art.
- *&* document member of the same patent family

Date of the actual completion of the international search

2 June 2005

Date of mailing of the international search report

13/06/2005

Name and mailing address of the ISA
 European Patent Office, P.B. 5818 Patentlaan 2
 NL - 2280 HV Rijswijk
 Tel. (+31-70) 340-2040, Tx. 31 651 epo nl,
 Fax: (+31-70) 340-3016

Authorized officer

Moeremans, B

INTERNATIONAL SEARCH REPORT

International Application No
Γ/GB2005/000417

C.(Continuation) DOCUMENTS CONSIDERED TO BE RELEVANT

Category °	Citation of document, with indication, where appropriate, of the relevant passages	Relevant to claim No.
X	US 2 059 937 A (ELLIS CHARLES D) 3 November 1936 (1936-11-03) figures 1-6 -----	1-4, 10
Y	US 1 511 123 A (HART CHARLES F) 7 October 1924 (1924-10-07) figures 4,5 -----	9

INTERNATIONAL SEARCH REPORT

International Application No

Γ/GB2005/000417

Patent document cited in search report		Publication date	Patent family member(s)	Publication date
GB 2332356	A	23-06-1999	NONE	
US 4306370	A	22-12-1981	CA 1127844 A1 DE 2912050 A1 ES 478982 A1 JP 54135157 A SE 7812432 A	20-07-1982 11-10-1979 16-10-1979 20-10-1979 29-09-1979
US 5172512	A	22-12-1992	AU 666671 B2 AU 2468692 A AU 673829 B2 AU 4062395 A CA 2092536 A1 DE 69224177 D1 DE 69224177 T2 EP 0553336 A1 MX 9204772 A1 WO 9303612 A1	22-02-1996 16-03-1993 28-11-1996 29-02-1996 20-02-1993 26-02-1998 07-05-1998 04-08-1993 01-03-1993 04-03-1993
US 5148624	A	22-09-1992	NONE	
US 2059937	A	03-11-1936	NONE	
US 1511123	A	07-10-1924	NONE	