



- (51) **International Patent Classification:**
F16K 5/06 (2006.01) *F16K 27/06* (2006.01)
- (21) **International Application Number:**
PCT/DK2014/050177
- (22) **International Filing Date:**
19 June 2014 (19.06.2014)
- (25) **Filing Language:** Danish
- (26) **Publication Language:** English
- (30) **Priority Data:**
PA 2013 70335 20 June 2013 (20.06.2013) DK
- (71) **Applicant:** BROEN A/S [DK/DK]; Skovvej 30, DK-5610 Assens (DK).
- (72) **Inventors:** LILDHOLDT, Mads Lindegaard; Trunderupvej 48, DK-5683 Haarby (DK). LILDHOLDT, Karin Birthe Lindegaard; Trunderupvej 48, DK-5683 Haarby (DK). MADSEN, Peder; Sanderumvej 4, DK-5250 Odense SV (DK).
- (74) **Agent:** PATRADE A/S; Fredens Torv 3A, DK-8000 Aarhus C (DK).

(81) **Designated States** (unless otherwise indicated, for every kind of national protection available): AE, AG, AL, AM, AO, AT, AU, AZ, BA, BB, BG, BH, BN, BR, BW, BY, BZ, CA, CH, CL, CN, CO, CR, CU, CZ, DE, DK, DM, DO, DZ, EC, EE, EG, ES, FI, GB, GD, GE, GH, GM, GT, HN, HR, HU, ID, IL, IN, IR, IS, JP, KE, KG, KN, KP, KR, KZ, LA, LC, LK, LR, LS, LT, LU, LY, MA, MD, ME, MG, MK, MN, MW, MX, MY, MZ, NA, NG, NI, NO, NZ, OM, PA, PE, PG, PH, PL, PT, QA, RO, RS, RU, RW, SA, SC, SD, SE, SG, SK, SL, SM, ST, SV, SY, TH, TJ, TM, TN, TR, TT, TZ, UA, UG, US, UZ, VC, VN, ZA, ZM, ZW.

(84) **Designated States** (unless otherwise indicated, for every kind of regional protection available): ARIPO (BW, GH, GM, KE, LR, LS, MW, MZ, NA, RW, SD, SL, SZ, TZ, UG, ZM, ZW), Eurasian (AM, AZ, BY, KG, KZ, RU, TJ, TM), European (AL, AT, BE, BG, CH, CY, CZ, DE, DK, EE, ES, FI, FR, GB, GR, HR, HU, IE, IS, IT, LT, LU, LV, MC, MK, MT, NL, NO, PL, PT, RO, RS, SE, SI, SK, SM, TR), OAPI (BF, BJ, CF, CG, CI, CM, GA, GN, GQ, GW, KM, ML, MR, NE, SN, TD, TG).

Published:

— with international search report (Art. 21(3))

(54) **Title:** SPRING GASKET FOR A VALVE HOUSING

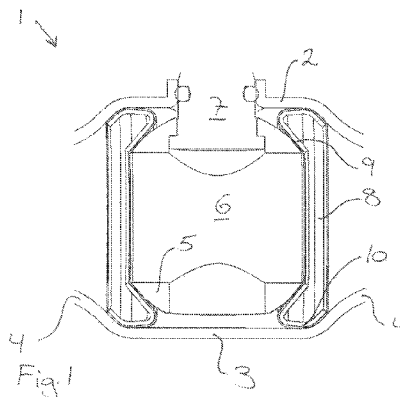

(57) **Abstract:** The present invention concerns a valve and a method for producing a valve for regulating a fluid, the valve including a valve housing with a central part and with two connection ends, the connection ends extending away from the central part, thus indicating a flow direction for the fluid, wherein internally of the central part there is arranged a valve body including at least a shutoff part and a through-flow part. The valve seat is arranged in the valve housing and resiliently bearing against the valve body, the valve seat including a resilient structural part where the spring action from the resilient structural part acts in a direction which is substantially in parallel with the flow direction of the valve, and where the resilient structural part includes at least one annular flange part adapted for direct or indirect bearing on the valve body. The new feature of a valve according to the invention is that the resilient valve seat or seats include a fixing member for mechanical fixing of the valve seat in a valve housing, the fixing member including means, for example a flange part, fixed in a valve housing by plastic deformation of the valve housing and/or by plastic deformation of the means.

WO 2014/202093 A1

SPRING GASKET FOR A VALVE HOUSING

Field of the Invention

The present invention concerns a valve for regulating a fluid, wherein the valve includes a valve housing with a central part and with two connection ends, the connection ends extending away from the central part, thus indicating a flow direction for the fluid, wherein internally of the central part there is arranged a valve body including an at least partially spherical surface for bearing against a corresponding valve seat, the valve body including at least a shutoff part and a through-flow part.

10 The invention further includes a method for making such a valve.

Background of the Invention

It is commonly known to make valves, e.g. ball valves, and thereby valve housings of several parts and then assemble these parts around one or two valve seats and a valve body. Such valves are typically made of brass or other copper-based alloy and are typically assembled by corresponding screw threads in respective parts, or alternatively by means of bolts.

When speaking of a ball valve, the valve body is, as indicated by the name, spherical and typically with an outer size which is greater than the connecting openings in the valve housing. Such a valve therefore has a valve housing with an internal geometry in which valve seat and valve body are disposed. The valve housing is typically joined in the vicinity of the valve body as the latter requires the largest internal dimension.

Such valves are typically made of cast items which are formed and shaped by machining by cutting operation to the desired geometry. This shaping process is, however, rather cost-intensive for several reasons. The individual work pieces are to be cast and then handled and machined one by one in a suitable metal cutting unit. Since the work pieces are individually machined, the process is time-consuming, irrespective of the application of modern and relatively rapid processes.

In addition to the handling and machining of the cast work pieces prior to assembling around one or two valve seats and a valve body, the cost of the material also plays a significant role. Brass or other suitable alloys are expensive, entailing an appreciably greater cost than e.g. common weldable carbon steel.

US 2011/233438 A1 discloses a valve wherein the valve seat includes a resilient structural part where the spring action from the resilient structural part acts in a direction which is substantially in parallel with the flow direction of the valve, and including an annular flange part adapted for direct or indirect bearing against the valve body. This resilient structural part is placed in a valve housing which is shaped, possibly before mounting one connection end. This implies that the mounting of the resilient structural parts in the central part of the valve housing is impeded, and that the making of the valve therefore can take longer time and entail increased production costs.

There is thus an expressed desire for making valves for heating and cooling systems, for potable water and for other purposes in steel, e.g. carbon steel or stainless steel which is cheaper than the common alloys and which can be worked with modern production equipment directly from a plate piece or a tube piece faster and cheaper than possible when casting and machining work pieces of e.g. brass.

At the same time, it is greatly desired to entirely avoid performing welding processes on a valve as such processes cause respective work pieces to be set up in production at least one more time and the welding process itself is to be performed, which of course raises the cost of the product.

In addition, it is desired to perform a rapid and simple mounting of valve seat as well as valve body while at the same time a high quality and a secure and unambiguous disposition of these parts in relation to the valve housing and to each other are achieved.

Object of the Invention

It is the object of the invention to indicate a solution to the above problem wherein a valve is made with a valve housing and with at least one valve seat which is easily and unimpeded can be mounted and fixed together with the valve body, wherein a
5 minimum number of chip removing and cutting processes are performed before mounting a valve seat and a valve body,

Description of the Invention

As mentioned in the introduction, the invention concerns a valve for regulating a fluid, wherein the valve includes a valve housing with a central part and with two
10 connection ends, the connection ends extending away from the central part, thus indicating a flow direction for the fluid, wherein internally of the central part there is arranged a valve body including an at least partially spherical surface for bearing against a corresponding valve seat, the valve body including at least a shutoff part and a through-flow part. The valve seat is arranged in the valve housing and resiliently
15 bearing against the valve body, the valve seat including a resilient structural part where the spring action from the resilient structural part acts in a direction which is substantially in parallel with the flow direction of the valve, and where the resilient structural part includes at least one annular flange part adapted for direct or indirect bearing on the valve body.

20

The new feature of a valve according to the invention is that it is adapted such that the resilient valve seat or seats include a fixing member for mechanical fixing of the valve seat in a valve housing, the fixing member including means, for example a flange part, fixed in a valve housing by plastic deformation of the valve housing and/or by plastic
25 deformation of the means.

25

A preferred method for this purpose is that the valve housing is made of a plastically deformable tubular workpiece, and that the valve seat is fixed herein by deformation of the tubular workpiece. Such a deformation can include locking of a valve seat at a
30 given position as the valve housing is deformed, thereby securing the valve seat in the desired position, but a deformation may also occur of valve housing as well as the mentioned fixing member whereby the same mechanical fixing or locking the valve seat is achieved.

30

The resilient structural part thus exerts a resilient pressure between the valve housing and the valve body whereby a sealing is achieved between valve body and valve seat, and where it is possible to achieve a sealing between valve housing and valve seat as well, depending on the design of the construction. The resilient action of the valve seat or of its resilient structural part provides that a valve seat can absorb tolerances within a relatively wide range why a greater certainty of the intended operation of the valve can be achieved. This is achieved in that there is an annular flange part which at least partially applies a resilient pressure against the valve body. In that it is a resilient flange that interacts with the valve body, the contact pressure and thereby the friction between valve seat and valve body can more easily be kept at a necessary and at the same time relatively low level. By the prior art solutions with valve seats constituted by solid elastomeric items mounted in the valve housing, it is necessary to ensure and maintain a relatively high pressure between valve seat and valve body, as it is the inherent elasticity of the elastomeric member that absorbs tolerances and ensures a sufficient contact pressure between respective parts, a pressure typically of such magnitude that a relatively high friction is produced between valve seat and valve body. The flange part thus has the advantage of not being an elastic solid item that is compressed but a flange part acting resiliently as its action is applied a projecting annular flange part, a kind of cantilever upon which the packing element in the form of an elastomeric item can be arranged.

A valve according to the invention can include a valve housing with a valve body and with one valve seat arranged in a cutout or recess adapted for the purpose in the valve housing and bearing against the valve body. The valve body can be a more or less traditionally spherical valve body, but it may also be a valve body that only includes part of a spherical shell, thus including at least a spherical subarea on the shutoff part of the valve body corresponding to the shape of the valve seat at the side facing the valve body. By designing the resilient part of the valve seat as a flange part extending more or less radially relative to the valve body or to the passage through the through-flow part of the valve body, there is achieved a suitable contact pressure against the valve body and thereby a suitable but modest friction. The valve may right away be with only one resilient valve seat for bearing against one side of a valve body.

In a variant of a valve according to the invention, the valve can include two oppositely directed, resilient valve seats. Thus there may be arranged one valve seat at either side of e.g. a spherical valve body in a classic ball valve. In such a case the two valve seats will each exert a resilient force on the valve body which will contribute to position the valve seat itself in a kind of equilibrium position at which the actions from the two valve seats are the same.

A valve according to the invention can be adapted such that the resilient valve seat or seats include a fixing member for mechanical fixing of the valve seat in a valve housing, the fixing member including means for disposition in a recess or similar in a valve housing. Such a solution may advantageously be used in larger valves with a flow aperture of 50, 100, 200 mm or even larger, but also in smaller valves. By adapting the valve seat with a so-called fixing member which e.g. can be a cylindrical part with radially outward projecting flange part which either constitutes the flange part to bear directly or indirectly on the valve body or a flange part between the cylindrical part and the flange part to bear directly or indirectly on the valve body, it will be possible to dispose the valve seat in a groove, recess or a fit adapted for the purpose in the valve housing, where e.g. a packing can be provided as well. Such a packing can be arranged between the cylindrical fixing part and a more or less radial flange part on the valve seat on the one hand and on the valve housing itself on the other hand. In the following, an example thereof will be described with reference to a Figure.

A valve according to the invention may advantageously be adapted such that the resilient valve seat or seats include a fixing member for mechanical fixing of the valve seat in a valve housing, the fixing member including means, for example a flange part, fixed in a valve housing by plastic deformation of the valve housing and/or by plastic deformation of the means. A preferred method for this purpose is that the valve housing is made of a plastically deformable tubular workpiece, and that the valve seat is fixed herein by deformation of the tubular workpiece. Such a deformation can include locking of a valve seat at a given position as the valve housing is deformed, thereby securing the valve seat in the desired position, but a deformation of valve

housing as well as the mentioned fixing member may also occur whereby the same mechanical fixing or locking of the valve seat is achieved.

5 In a variant of a valve according to the invention, the resilient valve seat or seats can include a fixing member for mechanical fixing of the valve seat in a valve housing, the fixing member including means in the form of a flange part that is conical in a direction which is substantially in parallel with the flow direction, the flange part including an annular part, the said part including an external edge adapted for fixing internally of the valve housing, the edge constituting or comprising a barb for
10 engaging the internal surface of the valve housing as the external diameter of the flange part is greater than the internal diameter of the valve housing at the area in which the valve seat is disposed. When the valve body and one or two valve seats are mounted in the valve housing it is thus not required with a further fixing as the conical flange part so to say is cutting into the internal surface of the valve housing, thereby
15 locking the valve seat in its final position. In principle is used the same technique as known from the so-called spring-lock disks and which is also used in e.g. push-in fittings for compressed air and for other purposes. Here, it is just so that the resilient and locking element is provided internally and not externally of the object to be fixed.

20 In a valve according to the invention, the valve seat can be made of resilient metal, e.g. stainless steel or other suitable alloy, wherein at least part of the valve seat, e.g. the resilient structural part in the form of an annular flange part, is coated with a relatively thin elastomeric surface, e.g. PTFE or other suitable type of elastomer with suitable coefficient of friction and sealing action. By such a solution there is thus
25 direct contact between the annular flange part and the valve body. The sealing effect can appear between valve seat and valve body, but also between the edge of the valve seat engaging or bearing on the valve housing, irrespectively of the valve seat being fixed by resilient locking or by deformation of valve housing and/or valve seat.

30 In a variant of a valve according to the invention, the valve seat can be made of resilient metal, e.g. stainless steel or other suitable alloy, wherein at least part of the valve seat, e.g. the resilient structural part in the form of an annular flange part, includes a contact surface for an elastomeric packing, e.g. a ring of PTFE or other

suitable type of elastomer with suitable coefficient of friction and sealing action. By such a variant, the annular flange part can be with a recess or cutout in which an annular elastomeric packing is arranged, thus causing the flange part to bear directly against the valve body. The resilient structural part is thus one member whereas the packing part itself is constituted by a second member arranged on or in the annular flange part. In the following such a solution will be described with reference to a Figure.

The valve body can also be coated with a surface coating, e.g. an elastomer in the form of PTFE or other suitable elastomer, and valve body as well as valve seat can be provided with such suitable coating in addition to the valve body being provided with a suitable sealing or low friction coating that interacts with a packing member arranged on or in an annular flange part.

Yet a variant of a valve according to the invention can include that the valve seat includes a tubular flange part with internal cross-sectional area, the tubular flange part extending away from the valve body and towards a connection end, where the internal cross-sectional area substantially corresponds to the internal cross-sectional area of the through-going opening in the valve housing. In a particularly preferred embodiment, the tubular flange part extends from the flange part bearing against the valve body or from a recess on a flange part for a valve seat packing. The main purpose of the tubular flange part is to guide the medium for which the valve is intended. By having a tubular flange a more controlled flow of medium is ensured before and/or after a valve body where typically there will be a jump in diameters. The tubular flange part acts as a kind of skirt that guides the medium.

Irrespective of the type of the mentioned valve seats applied, they can advantageously be mounted by or in glue. The glue is typically applied internally of the valve housing, and the valve seat is mounted subsequently; alternatively the glue can be applied the valve seat prior to mounting the latter. The glue will ensure that the valve seat is retained at the desired position both during the continued shaping of the valve and during the subsequent use of the valve, and the glue will also ensure a sealing between the valve housing and the external periphery of the valve seat as small scratches or

irregularities in the internal surface of the valve housing and on the periphery of the valve seat are filled by the glue.

5 In a preferred variant of a valve according to the invention, the valve body and at least one valve seat can be fixed in a valve housing, the valve housing having two connection ends, each with a diameter such that at least one connection end has a diameter substantially corresponding to the diameter of either the valve body or of a valve seat. The valve body and the valve seat can hereby be mounted internally of the valve housing via its connection end, and there is no need for making the valve
10 housing in several parts in order to assemble these around valve body and/or valve seats.

The invention furthermore concerns a method for making a valve as mentioned above, wherein the valve is adapted for regulating a fluid, the valve including a valve housing
15 with a central part and with two connection ends, the connection ends extending away from the central part, thus indicating a flow direction for the fluid, wherein internally of the central part there is arranged a valve body including an at least partially spherical surface for bearing against a corresponding valve seat, the valve body including at least a shutoff part and a through-flow part, wherein making of the valve
20 at least includes the following steps:

- providing a valve housing with a central part;
- arranging a valve body in the central part;
- arranging and fixing at least one valve seat in the central part and bearing against the valve body.

25

A method according to the invention may in a variant at least include the following additional steps:

- fixing of the at least one valve seat is effected by deformation of the valve housing, the deformation being made after arranging the valve seat in the central part.

30

A further method according to the invention may at least include the following additional steps:

- fixing of the at least one valve seat is effected by deformation of at least one flange part of the valve seat.

By the mentioned methods a valve according to the invention can be mounted, and the valve body as well as one or two valve seats can be fixed in a simple and rapid way
5 via one or both connection ends of the valve housing. Whether fixing a valve seat by deformation of valve housing and possibly also by a fixing member on the valve seat, or whether fixing occurs by the valve seat via a fixing member exerting a resilient force against the internal side of the valve housing, a rapid and easy mounting of
10 respective parts in relation to each other takes place.

Examples of how a valve according to the invention can look like will be shown in the following.

15 By this method, the valve can be made of e.g. untreated steel in a series of contiguous and automated processes, and before or after mounting the production can end with a surface finishing. Such a valve and method for producing a valve is very advantageous as the process is simple and takes place in a straightforward sequence.

20 In a preferred variant of the invention, the valve housing can, however, advantageously be made of e.g. a carbon steel which already has been applied a surface coating of zinc or other suitable coating. For example, a steel tube galvanised by a suitable galvanising process can be used. Hereby is achieved the obvious advantage that the surface treatment is performed before working the valve housing
25 into its final geometric shape, entailing a lower production cost of the finished product.

A valve including a valve housing according to the invention is typically designed such that the connection ends have an inner diameter which substantially corresponds
30 to the inner diameter of the valve body. This is therefore a so-called fullflow valve which advantageously can be used in many places where there is a need for a more unhindered flow in the medium flowing through the valve. The connection ends on the valve housing can be designed according to need and can be with male ends or

female ends and include all thinkable types of couplings for connecting pipes or hoses, including couplings of the press-fitting type and flanges for bolt assemblies or for a suitable assembly fitting.

5 At the time being, thinwalled materials gain a foothold in the industry and are increasingly applied to industrial solutions as well as to plumbing installations in residential buildings. There are innumerable advantages connected with thinwalled pipes and fittings and the jointing methods are very simple, why time-consuming and cost-raising work of threading, welding or soldering is avoided.

10

A valve housing according to the invention can advantageously be made of thinwalled material, such as untreated or surface treated carbon steel or stainless steel, where the valve housing is formed by plastic deformation of the material, e.g. by hydraulic shaping or by axial shaping or by another suitable process. Particularly hydraulic
15 shaping and axial shaping have appeared to be very well suited for making a valve housing as such processes are rapid and cheap compared with traditional production methods for valve housings, which are typically made of sintered, cast or forged brass or other suitable material which is machined afterwards and fitted with a valve insert. Furthermore, hydraulic shaping and axial shaping are very accurate shaping methods
20 and good tolerances can be attained.

Description of the Drawing

The invention is described in the following with reference to the drawing, wherein:

- Fig. 1 shows a sectional drawing of a valve with deformed connection ends.
Fig. 2 shows a sectional drawing of a valve with spring-locked valve seats.
25 Fig. 3 shows a valve seat with conical fixing part.
Fig. 4 shows a valve seat with deformed fixing part.
Fig. 5 shows a valve seat with a partial surface coating.
Fig. 6 shows a sectional drawing of a valve with only one valve seat.
Fig. 7 shows a valve seat as seen in Fig. 6.
30 Fig. 8 shows a sectional drawing of a variant of a valve with spring-locked valve seat.
Fig. 9 shows yet a sectional drawing of a valve with tubular flange on a spring-locked valve seat.

List of designations:

- | | | |
|----|-----|---|
| | 1. | valve |
| | 2. | valve housing |
| | 3. | central part |
| 5 | 4. | connection ends |
| | 5. | valve body |
| | 6. | through-going opening in valve body |
| | 7. | valve spindle |
| | 8. | valve seat |
| 10 | 9. | flange part against valve body |
| | 10. | flange part against internal side of valve housing |
| | 11. | layer of steel |
| | 12. | layer of surface coating |
| | 13. | edge on flange part facing internal side of valve housing |
| 15 | 14. | control spindle |
| | 15. | recess in valve housing |
| | 16. | recess for packing |
| | 17. | packing |
| | 18. | cylindrical flange part |
| 20 | 19. | radial flange |
| | 20. | conical inwardly facing flange |
| | 21. | recess on flange part against valve body |
| | 22. | valve seat packing |
| | 23. | contact surface in recess on flange part against valve body |
| 25 | 24. | cylindrical tubular flange part |
| | 25. | glue |

Detailed Description of Embodiments of the Invention

In Fig. 1 appears a part of a valve 1 in cross-section where a valve housing 2 comprises a central part 3 and two connection ends 4. In the central part 3 is arranged a valve body 5 with a through-going aperture 6. The valve body 5 is connected with a valve spindle 7 and is supported and fixed by two valve seats 8. In the shown variant, the valve seats 8 are fixed in that the two connection ends 4 are deformed into a smaller internal cross-section whereby the valve seats 8 are locked in their positions in

relation to the valve body 5 as well as to the valve housing 2. As it appears from the Figure, the valve seat 8 has a flange part 9 bearing against the valve body 5 and a flange part 10 bearing against the internal side of the valve housing 2. The flange part 9 bearing against the valve body 5 exerts a resilient action on the valve body 5
5 whereby a sealing is achieved between these parts. In that the valve seat 8 is made and mounted as shown here, the pressure exerted by a fluid by closed valve 1 can also act on the back side of the flange part 9, whereby the flange part 9 is pressed against the valve body 5, entailing an even more optimal sealing between the two items 5, 9.

10 Fig. 2 also shows a valve housing 2 with a central part 3 with connection ends 4 and with a valve body 5 arranged between two valve seats 8. The difference between this Figure and Fig. 1 is that the valve seats 8 are only fixed by the flange part 10 being pressed against the internal side of the valve housing 2, where a locking occurs according to the same principle as by the various known push-in fittings, wherein a
15 kind of resilient locking ring engages as a barb with - in this case - the internal surface of the valve housing. The valve seat 8 appears here as a two-layered construction being partly a rigid steel layer and partly a less rigid surface coating, e.g. PTFE or other suitable surface coating with the appropriate material properties for the actual task.

20 Fig. 2 may furthermore be viewed in a different way where the Figure shows a method step in which valve body 5 and the two valve seats 8 are arranged in a valve housing 2 immediately before it can be deformed as seen in Fig. 1. Both of the two views are relevant and a valve 1 according to the invention can, according to need or desire, be
25 made in both ways. Irrespectively of whether it is the cutting action from the flange 10 that acts as the final fixing or as a temporary fixing before deformation of the connection ends 4, the valve body 5 and the valve seats 8 can easily and without any substantial effort be placed at the desired position where a sufficient contact pressure is established between the valve body 5 and the valve seat 8. Common to the solutions
30 appearing in Figs. 1 and 2 is that valve body as well as valve seats and associated packings can be mounted in the central part 3 of the valve housing through one or both of the connection ends 4. Therefore there is no need for the valve housing 2 to be composed of several parts.

In Fig. 3 appears a cross-section of a valve seat 8 with conical fixing part corresponding to the flange part 10 and with the flange part 9 adapted for bearing against the valve body 5 itself. Furthermore is seen the previously mentioned two-layer construction where one layer 11 is steel while the other layer 12 is a surface coating, e.g. PTFE or other suitable material. The steel layer 11 has the purpose of providing rigidity and resiliency to the valve seat 8 whereas the surface coating 12 has the purpose of sealing between valve body 5 and valve seat 8 and at the same time exert such a modest/low friction between the two parts 5, 8 that the valve 1 can be operated between a closed and an open position. The layer 11, which is here of steel, can, however, also be made of other materials, including metal, synthetics, fibre-reinforced composites or other suitable materials. The same goes for the layer 12 of surface coating material which can be entirely omitted or alternatively be made of any other suitable material. The thickness of the layer 11 and the layer 12 can be chosen according to need such that the required elasticity, friction or other suitable parameter is achieved.

In Fig. 4 is also seen a cross-section of a valve seat 8 which is here shaped/deformed as shown in Fig. 1. This shaping may be performed before mounting in the valve housing 2 but may also occur during deformation of the valve housing 2 after positioning the valve body 5 and the valve seats 8. The coating 12 may furthermore be provided only on the part of the valve seat 8 that comes into contact with the valve body 5, which generally corresponds to the flange part 9.

Fig. 5 also shows a cross-section of a valve seat 8 with a partial surface coating 12, thus letting part of the flange part 10 stand without coating 12. A better contact between the edge 13 on the flange part 10 and the internal side of the valve housing 2 can hereby be achieved, which is particularly advantageous in case that the valve seats are mounted and fixed by the edge 13 cutting into internal surface of the valve housing. The shape of the layer 12 can be varied and applied according to need, and in the show example is seen that on the flange part 9 intended to face the valve body 5 there is arranged a coating 12 with a convex shape.

Fig. 6 shows a cross-sectional drawing of a valve 1 with only one valve seat 8 where the valve body 5 is constituted by a part of a spherical shell which therefore is not a closed spherical valve body 5 as shown in Figs. 1 and 2. The valve body 5 is here fitted with a valve spindle 7 but also with a control spindle 14 as shown at the top of the Figure. The valve seat 8 is also designed in a different way as it is fixed bearing against a recess 15 in the valve housing 2. The recess furthermore includes an additional recess 16 for a packing 17. The variant of a valve seat appearing in Fig. 6 is adapted with a cylindrical flange part 18 lying along the internal surface in the valve housing 2 and connected with a radial flange 19 which together with the cylindrical flange part 18 form a packing surface for contact with the packing 17. A conically inwardly facing flange 20 extends from the radial flange 19, the former connected with a conically outwardly facing flange part 9 adapted for bearing against the valve body.

By this variant of a valve 1 according to the invention, tolerances may thus be absorbed and/or a resilient action can be exerted against the valve body 25 from the flange part 9 but also from the conically inwardly facing flange 20 which together constitute a kind of elastic bellows.

Fig. 7 shows a valve seat 8 as seen and described in the description of Fig. 6.

Fig. 8 shows a cross-sectional drawing of yet a variant of a valve 1 with spring-locked valve seat 8 wherein appears part of a valve housing 2 with a central part 3, with connection end 4 and with a valve body 5 bearing against a valve seat 8. As also shown in Fig. 2, the valve seat 8 is here only fixed by the flange part 10 being pressed against the internal side of the valve housing 2 whereby a locking occurs according to the same principle as by the various known push-in fittings. By the shown variant of a valve 1, after mounting valve body 5 and valve seat 8 the connection end 4 is deformed to a lesser diameter than the central part 3 without the flange part 10 against the internal side of the valve housing 2 being deformed. However, it will also be possible to fix a valve seat 8 as shown in this Figure in the same way as shown in Fig. 1 where deformation of the flange part 10 is performed.

However, there is the more significant difference between the valve seat 8 in this Figure and the one shown in Fig. 2 in that a recess 21, in which a valve seat packing 22 is arranged, is formed in the valve seat 8 on the flange part 9. In this variant of a valve 1, both the valve seat packing 22 itself and the flange part 9 act resiliently against valve body 5, but the valve seat packing 22 can in principle be very stiff in relation to the flange part 9 such that it is the flange part 9 that provides the required and desired resilient force against the valve body 5.

The valve seat packing 22 can be mounted with e.g. glue for the flange part 9, it can be loose or it can be fixed by a kind of clamping into the structural part of the valve seat 8. For example, the flange part 9 can be designed with a cutout interacting with a corresponding projection on the valve seat packing 22 such that the two parts 8, 22 are entirely or partly fixed in relation to each other.

Fig. 9 shows yet a sectional drawing of a valve 1 with spring-locked valve seat 8. In principle this is a solution which is largely identical to the solution represented in Fig. 8. However, there is the difference that the valve seat 8 here includes a cylindrical tubular flange part 24 extending from the recess 21 on the flange part 9 in direction against the connection end 4. This cylindrical tubular flange part 24 provides for a markedly more uniform flow of the medium for which the valve 1 is used, as the medium so to say is guided by the direct path and does not flow so uncontrolledly in the area before and after valve body 6 and valve seats 8. In Fig. 9 is furthermore seen glue 25 ensuring tightness between valve housing 3 and valve seat 8.

The invention is not limited to the above described embodiments and not to the embodiments shown in the drawings either, but may be supplemented and modified in any way according to the invention as specified and defined in the claims.

CLAIMS

1. A valve (1) for regulating a fluid, the valve (1) including a valve housing (2) with a central part (3) and with two connection ends (4), the connection ends (4) extending away from the central part (3), thus indicating a flow direction for the fluid, wherein internally of the central part (3) there is arranged a valve body (5) including an at least partially spherical surface for contact against a corresponding valve seat (8), the valve body (5) including at least a shutoff part and a through-flow part, wherein the valve seat (8) is arranged in the valve housing (2) and resiliently bearing against the valve body (5), the valve seat (8) including a resilient structural part where the spring action from the resilient structural part acts in a direction which is substantially in parallel with the flow direction of the valve (1), and where the resilient structural part includes at least one annular flange part (9) adapted for direct or indirect bearing on the valve body (5), **characterised in** that the resilient valve seat or seats (8) include a fixing member (10, 11, 13, 18, 19) for mechanical fixing of the valve seat (8) in a valve housing (2), the fixing member (10, 11, 13, 18, 19) including means, for example a flange part (11), fixed in a valve housing (2) by plastic deformation of the valve housing (2) and/or by plastic deformation of the means.
2. Valve (1) according to claim 1, **characterised in** that the valve (1) includes two oppositely directed resilient valve seats (8).
3. A valve (1) according to any of claims 1 and 2, **characterised in** that the resilient valve seat or seats (8) include a fixing member (10, 11, 13, 18, 19) for mechanical fixing of the valve seat (8) in a valve housing (2), the fixing member (10, 11, 13, 18, 19) including means for disposition in a recess (15) or similar in a valve housing (2).
4. A valve (2) according to any of claims 1 and 2, **characterised in** that the resilient valve seat or seats (8) include a fixing member (10, 11, 13, 18, 19) for mechanical fixing of the valve seat (8) in a valve housing (2), the fixing member (10, 11, 13, 18, 19) including means in the form of a flange part (10) that is conical in a

direction which is substantially in parallel with the flow direction, the flange part (10) including an annular part, the said part including an external edge (13) adapted for fixing internally of the valve housing (2), the edge (13) constituting a barb for engaging the internal surface of the valve housing as the external diameter of the flange part (10) is greater than the internal diameter of the valve housing (2) at the area in which the valve seat (8) is placed.

5. A valve (1) according to any of claims 1 to 4, **characterised in** that the valve seat (8) is made of resilient metal, e.g. stainless steel or other suitable alloy, wherein at least part of the valve seat (8), e.g. the resilient structural part in the form of an annular flange part (9), is coated with an elastomeric surface (12), e.g. PTFE or other suitable type of elastomer with suitable coefficient of friction and sealing action.

6. A valve (1) according to any of claims 1 to 4, **characterised in** that the valve seat (8) is made of resilient metal, e.g. stainless steel or other suitable alloy, wherein at least part of the valve seat (8), e.g. the resilient structural part in the form of an annular flange part (9), includes a contact surface (23) for a valve seat/elastomer gasket (22), e.g. a ring of PTFE or other suitable type of elastomer with a suitable coefficient of friction and sealing action.

7. A valve (1) according to any of claims 1 to 6, **characterised in** that the valve seat (8) includes a tubular flange part (24) with internal cross-sectional area, the tubular flange part (24) extending away from the valve body (5) and towards a connection end (4), where the internal cross-sectional area substantially corresponds to the internal cross-sectional area of the through-going opening (6) in the valve housing (5).

8. A valve (1) according to any of claims 1 to 7, **characterised in** that the valve seat (5) and at least one valve seat (8) are fixed in a valve housing (2), the valve housing (2) having two connection ends (4), each with a diameter such that at least one connection end (4) has a diameter substantially corresponding to the diameter of either the valve body (5) or of a valve seat (8).

9. A method for making a valve (1) according to claims 1 to 8, the valve (1) adapted for regulating a fluid, wherein the valve (1) includes a valve housing (2) with a central part (3) and with two connection ends (4), the connection ends (4) extending away from the central part (3), thus indicating a flow direction for the fluid, wherein
5 internally of the central part (3) there is arranged a valve body (5) including an at least partially spherical surface for bearing against a corresponding valve seat (8), the valve body (5) including at least a shutoff part and a through-flow part, **characterised in** that the making of the valve housing (1) at least includes the following steps:
- providing a valve housing (2) with a central part (3);
 - 10 - arranging a valve body (5) in the central part (3);
 - arranging and fixing at least one valve seat (8) in the central part (3) and bearing against the valve body (5).

10. A method according to claim 9, **characterised in** that the method includes at
15 least the additional following steps:
- fixing of the at least one valve seat (8) is effected by deformation of the valve housing (2), the deformation being made after arranging the valve seat (8) in the central part (3).

- 20 11. A method according to any of claims 9 and 10, **characterised in** that the method includes at least the additional following steps: fixing of the at least one valve seat (8) is effected by deformation of at least one flange part (10) on the valve seat (8).

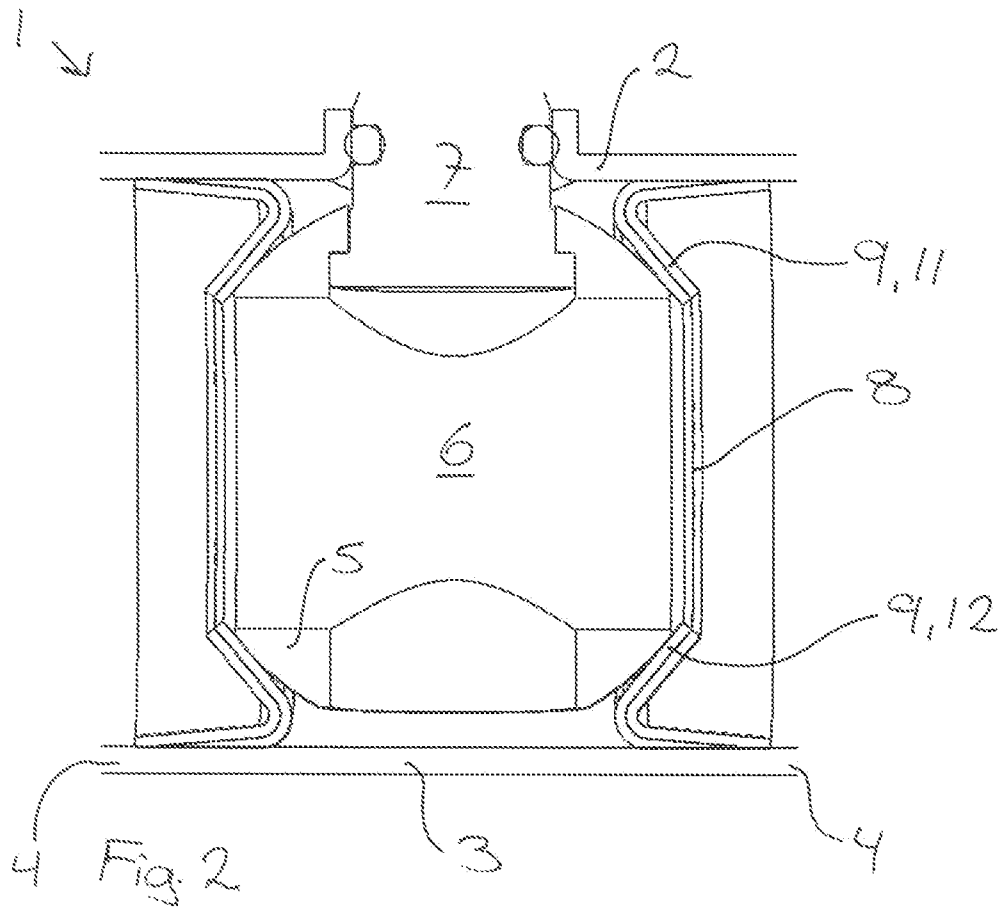
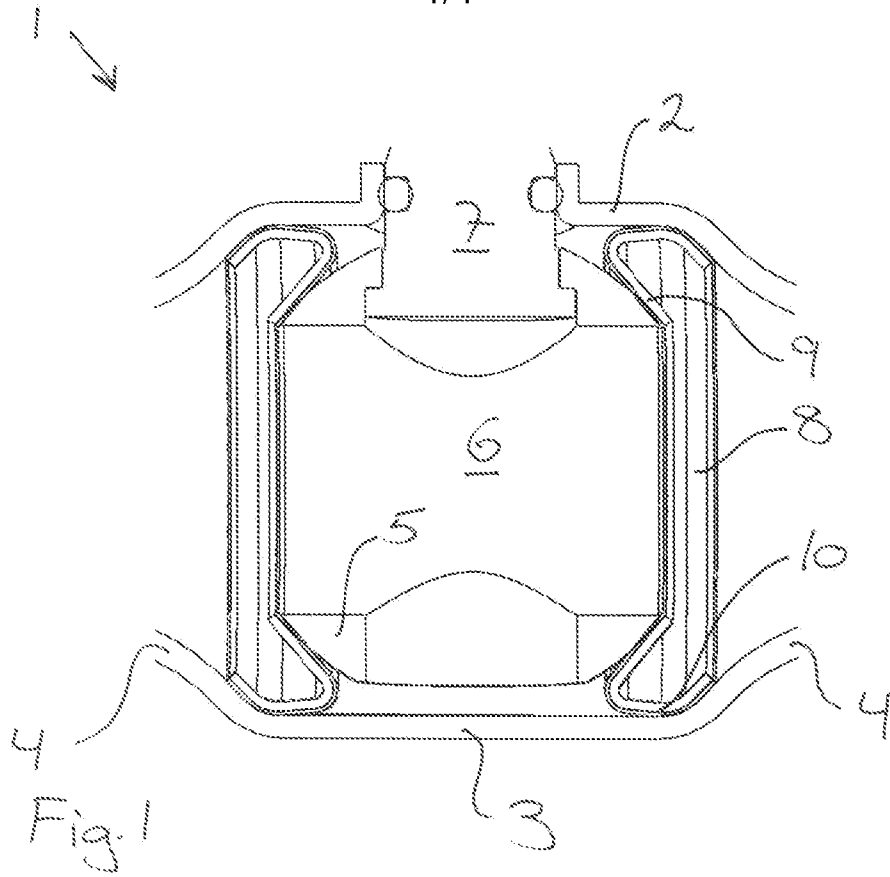

2/4

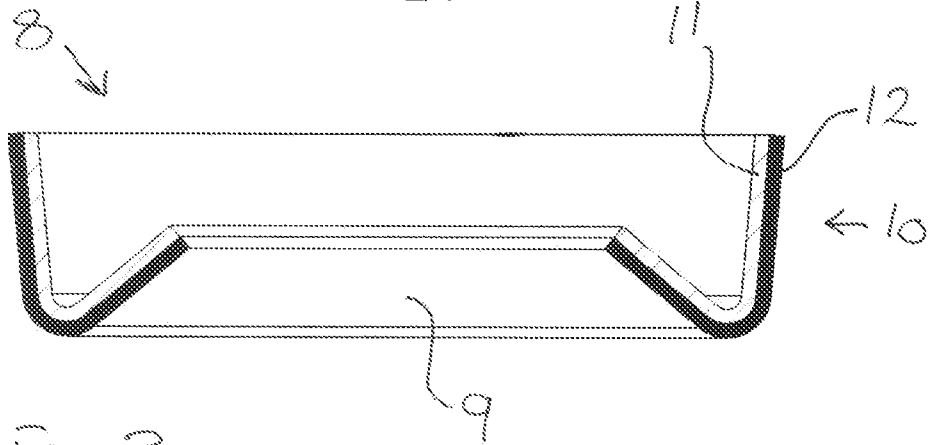

Fig. 3

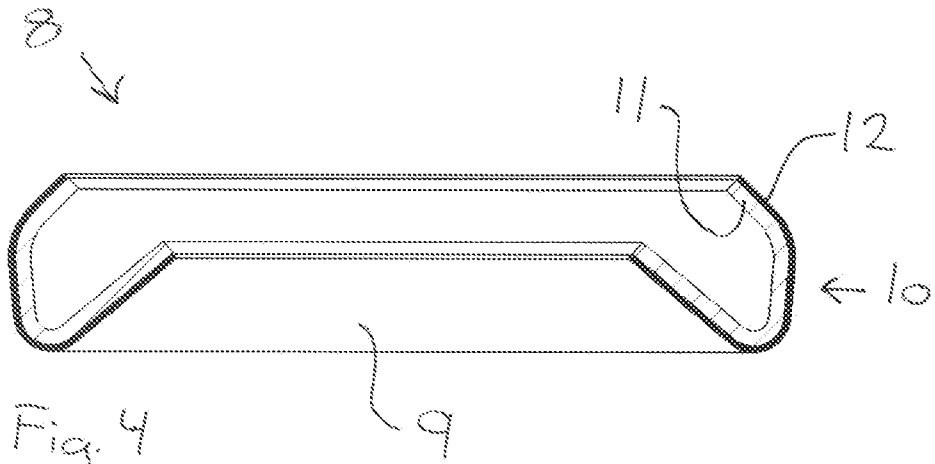

Fig. 4

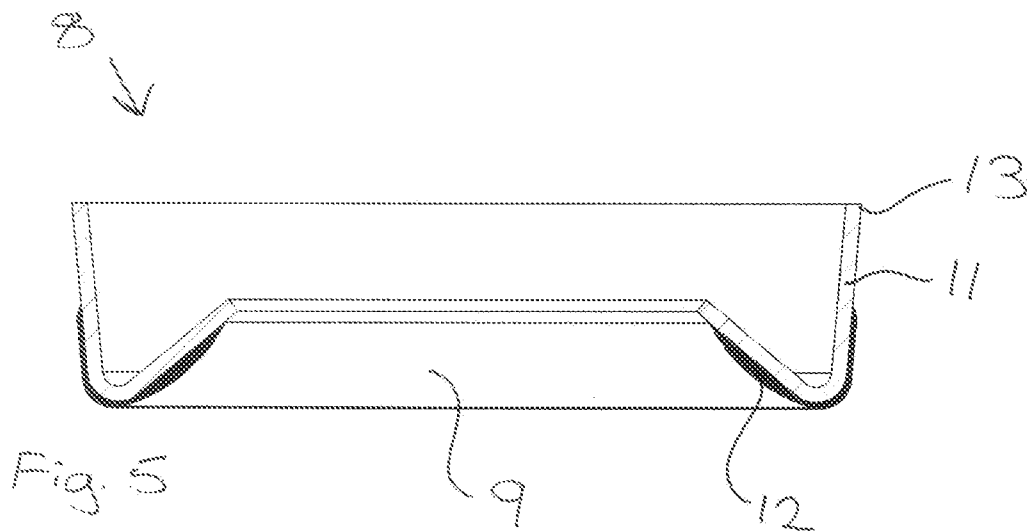

Fig. 5

3/4

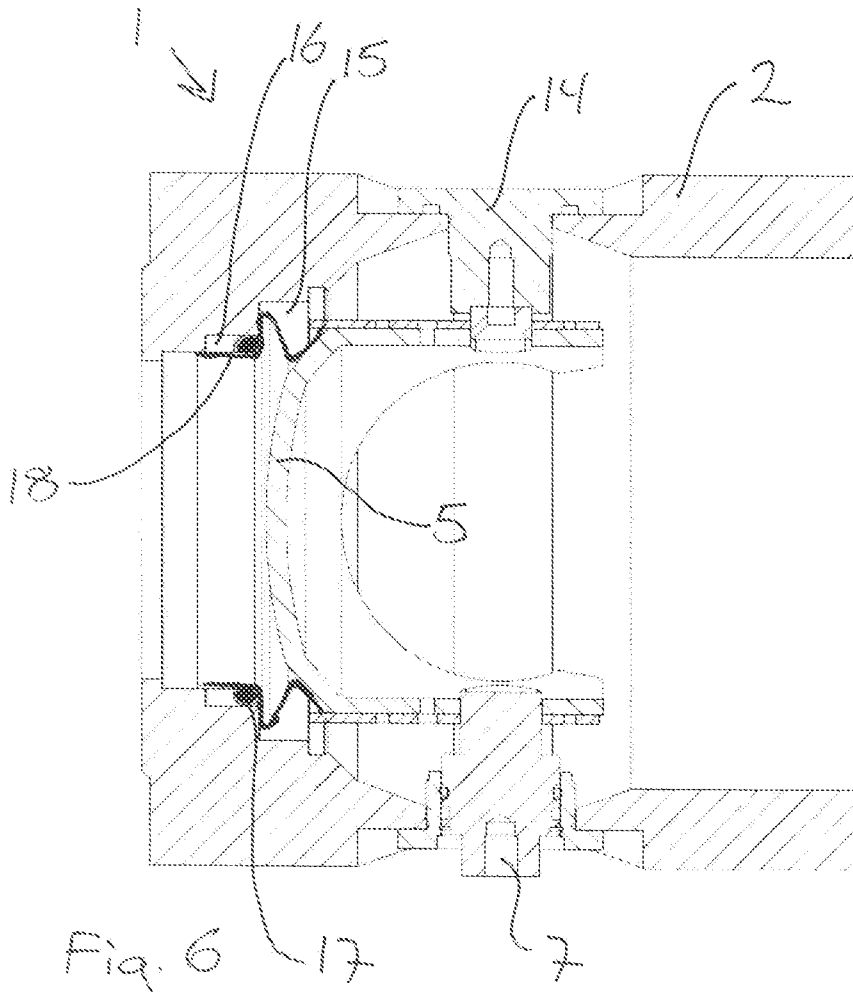

Fig. 6

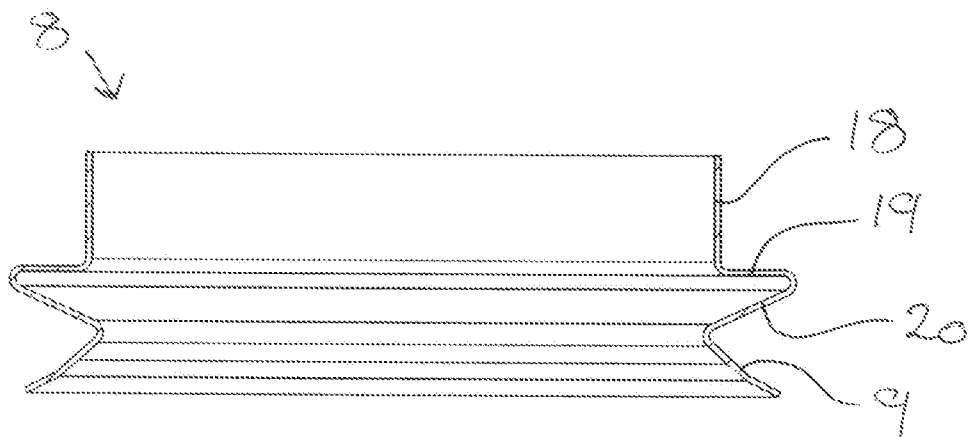
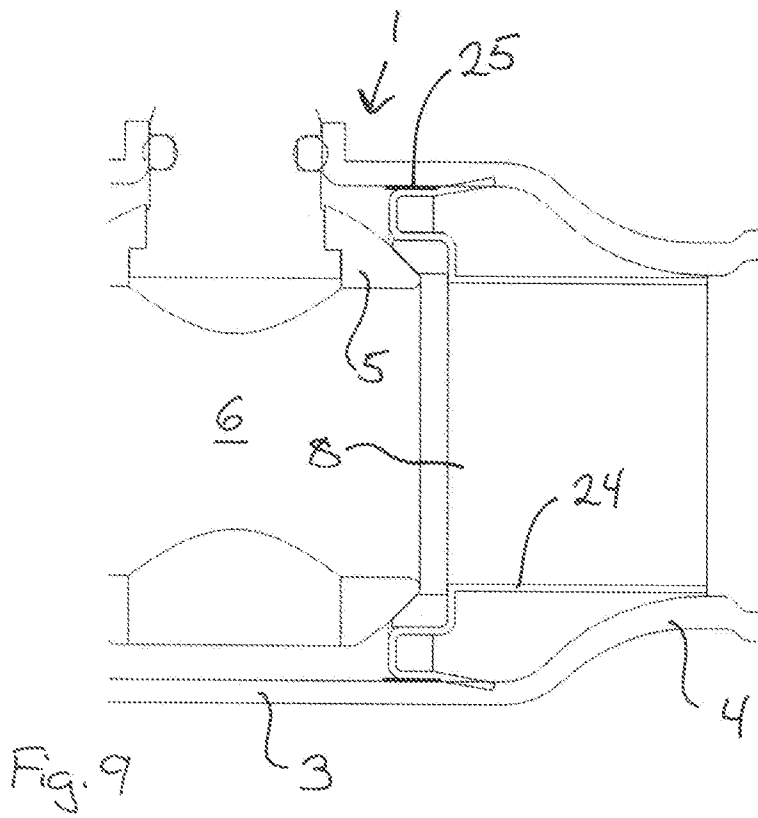
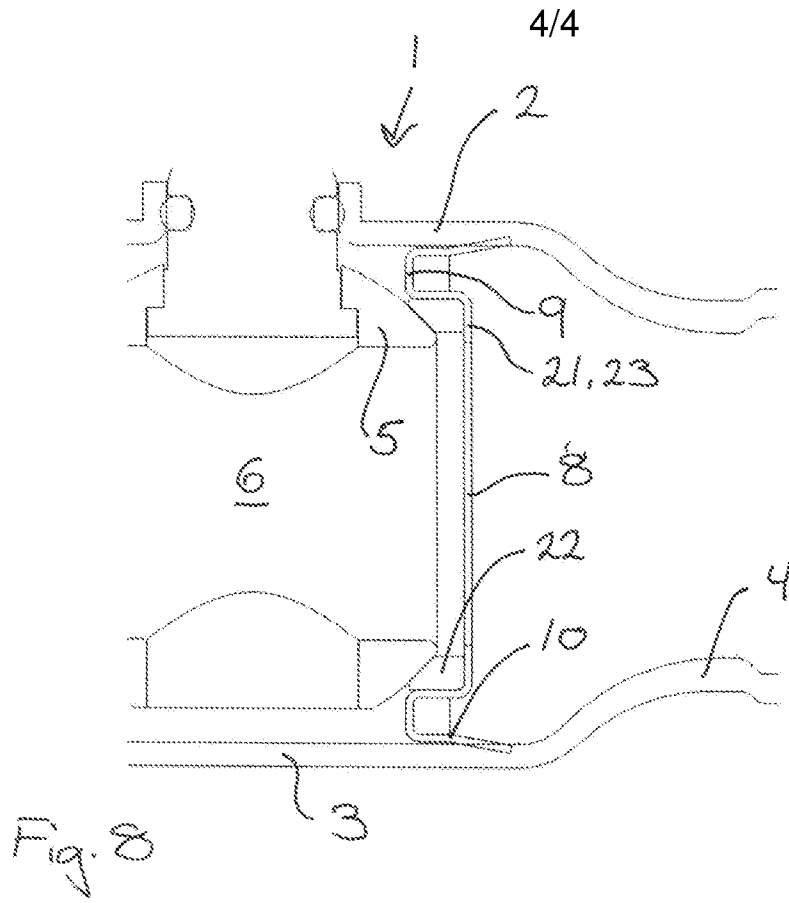

Fig. 7



INTERNATIONAL SEARCH REPORT

International application No.

PCT/DK2014/050177

A. CLASSIFICATION OF SUBJECT MATTER F16K 5/06 (2006.01F16K 27/06 (2006.01)) According to International Patent Classification (IPC) or to both national classification and IPC		
B. FIELDS SEARCHED Minimum documentation searched (classification system followed by classification symbols) ECLA, IPC, CPC: F16K		
Documentation searched other than minimum documentation to the extent that such documents are included in the fields searched DK, NO, SE, FI: Classes as above.		
Electronic data base consulted during the international search (name of data base and, where practicable, search terms used) EPODOC, WPI, TXTE, TXTEN		
C. DOCUMENTS CONSIDERED TO BE RELEVANT		
Category*	Citation of document, with indication, where appropriate, of the relevant passages	Relevant to claim No.
A	US2011233438 A1 (HUBACEK MIROSLAV et al.) 29.09.2011	1-11
A	EP2280204 A1 (VALBART S R L) 02.02.2011	1-11
A	US2012167987 A1 (BALAN MIRCEA et al.) 05.07.2012	1-11
A	US5904337 A (VANKIRK LEROY et al.) 18.05.1999	1-11
<input type="checkbox"/> Further documents are listed in the continuation of Box C. <input checked="" type="checkbox"/> See patent family annex.		
* Special categories of cited documents: "A" document defining the general state of the art which is not considered to be of particular relevance "E" earlier application or patent but published on or after the international filing date "L" document which may throw doubts on priority claim(s) or which is cited to establish the publication date of another citation or other special reason (as specified) "O" document referring to an oral disclosure, use, exhibition or other means "P" document published prior to the international filing date but later than the priority date claimed "T" later document published after the international filing date or priority date and not in conflict with the application but cited to understand the principle or theory underlying the invention "X" document of particular relevance; the claimed invention cannot be considered novel or cannot be considered to involve an inventive step when the document is taken alone "Y" document of particular relevance; the claimed invention cannot be considered to involve an inventive step when the document is combined with one or more other such documents, such combination being obvious to a person skilled in the art "&" document member of the same patent family		
Date of the actual completion of the international search 03/09/2014		Date of mailing of the international search report 08/09/2014
Name and mailing address of the ISA Nordic Patent Institute Helgeshøj Allé 81 DK - 2630 Taastrup, Denmark. Facsimile No. + 45 43 50 80 08		Authorized officer Niclas Skov Lindbæk Telephone No. +45 43 50 83 92

INTERNATIONAL SEARCH REPORT
Information on patent family members

International application No.

PCT/DK2014/050177

Patent document cited in search report / Publication date	Patent family member(s) / Publication date
US 2011233438 A1 2011.09.29	CA 2694864 A1 2010.05.25 CA 2694864 C 2011.09.20 US 8500090 B2 2013.08.06
EP 2280204 A1 2011.02.02	US 2011024662 A1 2011.02.03 JP 2011033189 A 2011.02.17 AU 2010204465 A1 2011.02.17 CN 101988593 A 2011.03.23
US 2012167987 A1 2012.07.05	WO 2012094137 A1 2012.07.12
US 5904337 A 1999.05.18	NONE