



US00RE33939E

**United States Patent** [19] **Cheng**

[11] E

**Patent Number: Re. 33,939**

[45] **Reissued Date of Patent: May 26, 1992**

[54] **TELESCOPIC AND COLLAPSIBLE GOLF CART**

[75] **Inventor: Alex Cheng, Taipei, Taiwan**

[73] **Assignee: Union Sports Co. Ltd., Taipei, Taiwan**

[21] **Appl. No.: 655,148**

[22] **Filed: Feb. 14, 1991**

4,657,100	4/1987	Lewis	280/464 X
4,784,401	11/1988	Raguet	280/DIG. 6 X
4,848,504	7/1989	Olson	280/DIG. 6 X
4,913,460	4/1990	Klein	280/646
4,946,186	8/1990	Cheng	280/646
4,961,593	10/1990	Sanders et al.	280/646

**FOREIGN PATENT DOCUMENTS**

714363	8/1954	United Kingdom	280/DIG. 6
870346	6/1961	United Kingdom	280/655

**Related U.S. Patent Documents**

Reissue of:

[64] **Patent No.: 4,946,186**  
**Issued: Aug. 7, 1990**  
**Appl. No.: 333,965**  
**Filed: Apr. 6, 1989**

[51] **Int. Cl.<sup>3</sup> ..... B62B 1/04**

[52] **U.S. Cl. .... 280/646; 280/655; 280/DIG. 6**

[58] **Field of Search ..... 280/DIG. 6, 39, 40, 280/42, 646, 652, 655**

[56] **References Cited**

**U.S. PATENT DOCUMENTS**

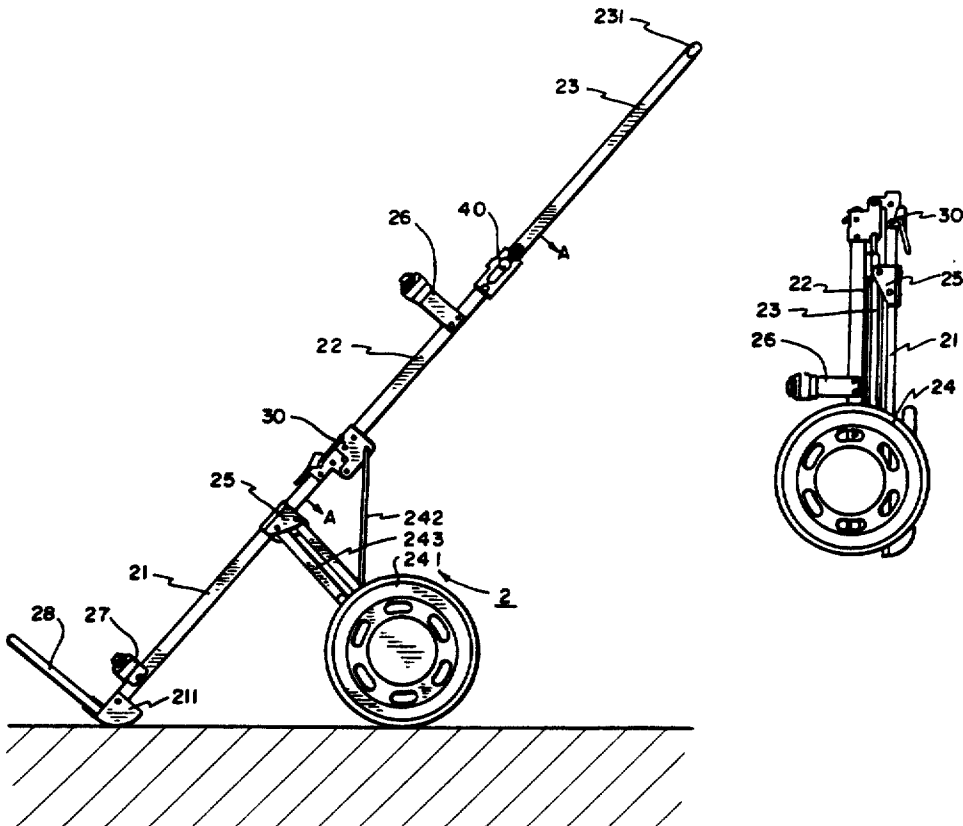
2,806,708	9/1957	Finstad	280/655
3,400,943	9/1968	Meiklejohn	280/646
4,455,030	6/1984	Rosen	280/DIG. 6 X

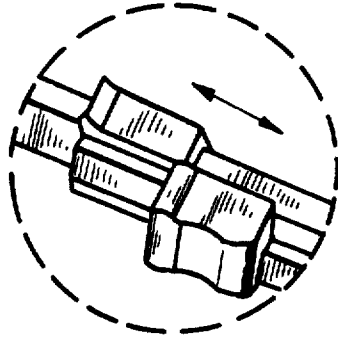
*Primary Examiner*—Andres Kashnikow  
*Assistant Examiner*—Brian L. Johnson  
*Attorney, Agent, or Firm*—Philip Furgang

[57] **ABSTRACT**

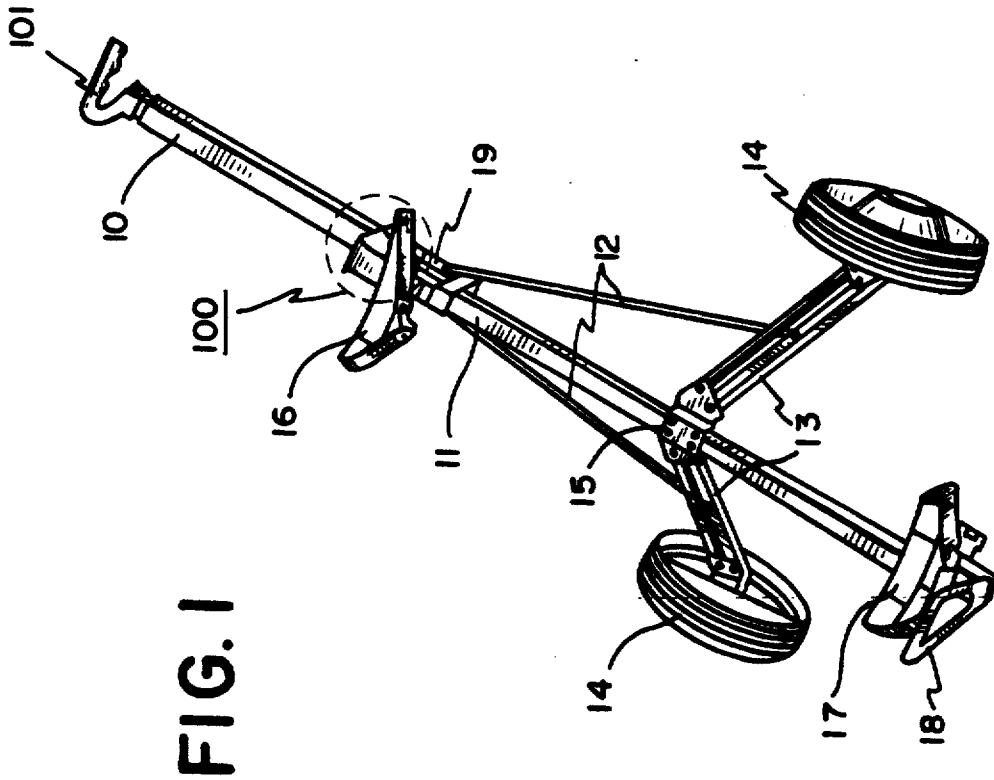
A telescopic and collapsible golf cart includes a longitudinal frame member having ground supporting wheels, spaced bag cradle with respective straps a support frame and a handle connected thereto. The frame member is divided into three sections wherein a first section and a second section are pivotally and laterally interconnected by a hinge and adapted to be swung between an aligned position and a position parallel to each other. A third section is adapted to telescope within a hollow inner space of the second section of the frame member.

**24 Claims, 6 Drawing Sheets**



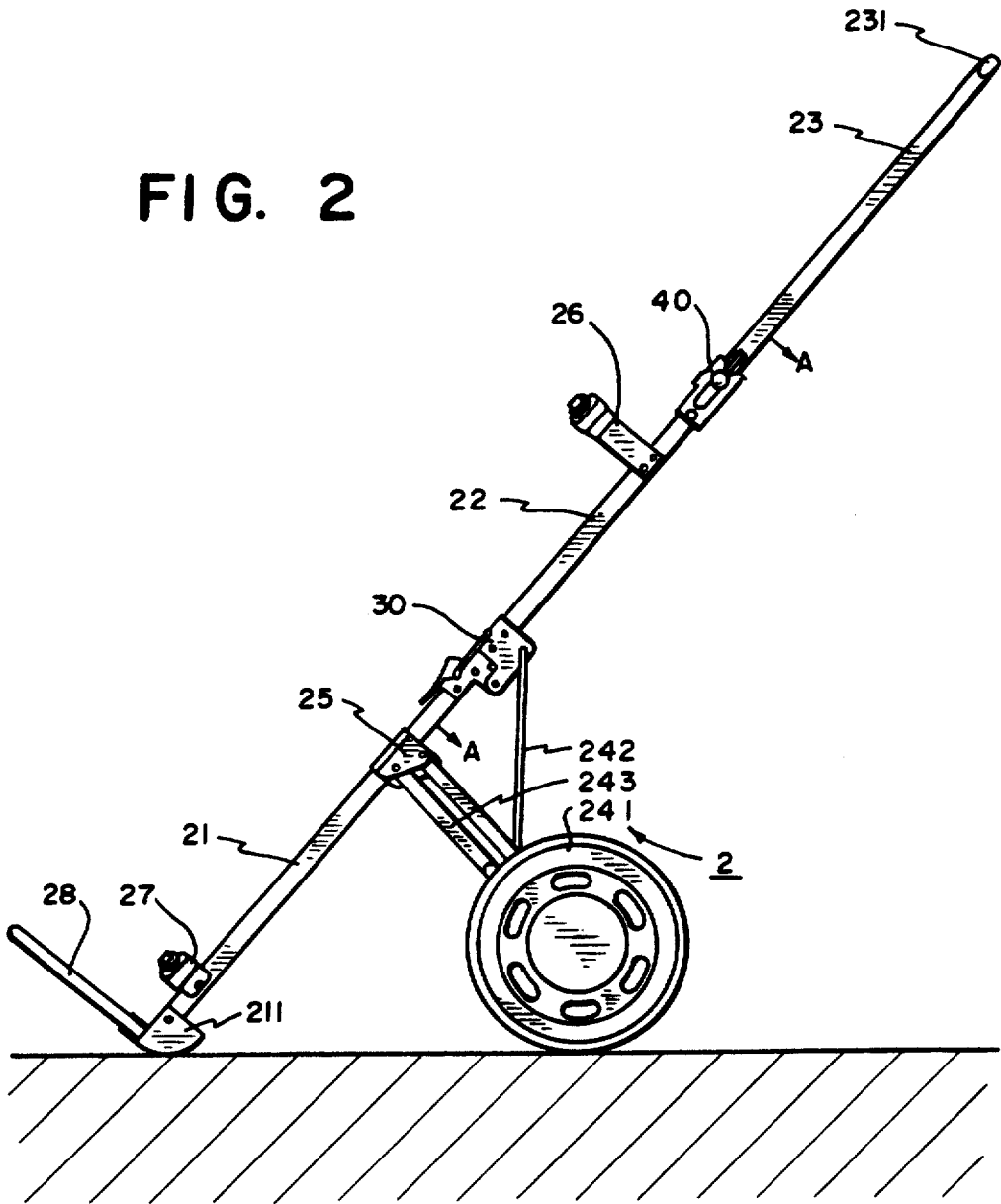


**FIG. 1A**  
PRIOR ART



**FIG. 1**

FIG. 2



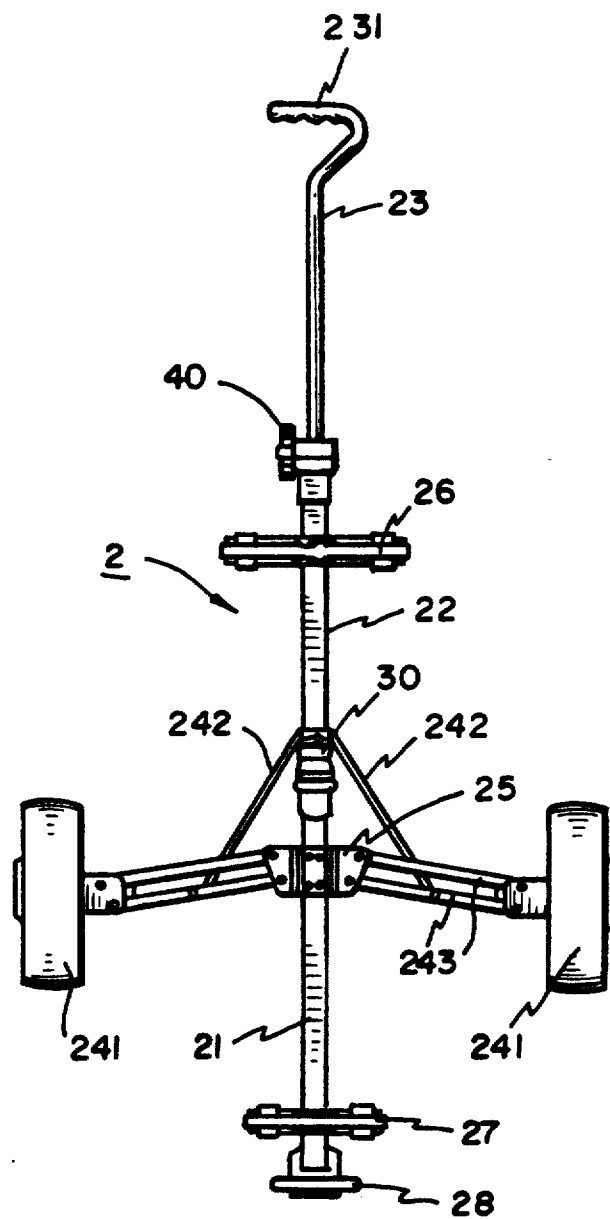


FIG. 3

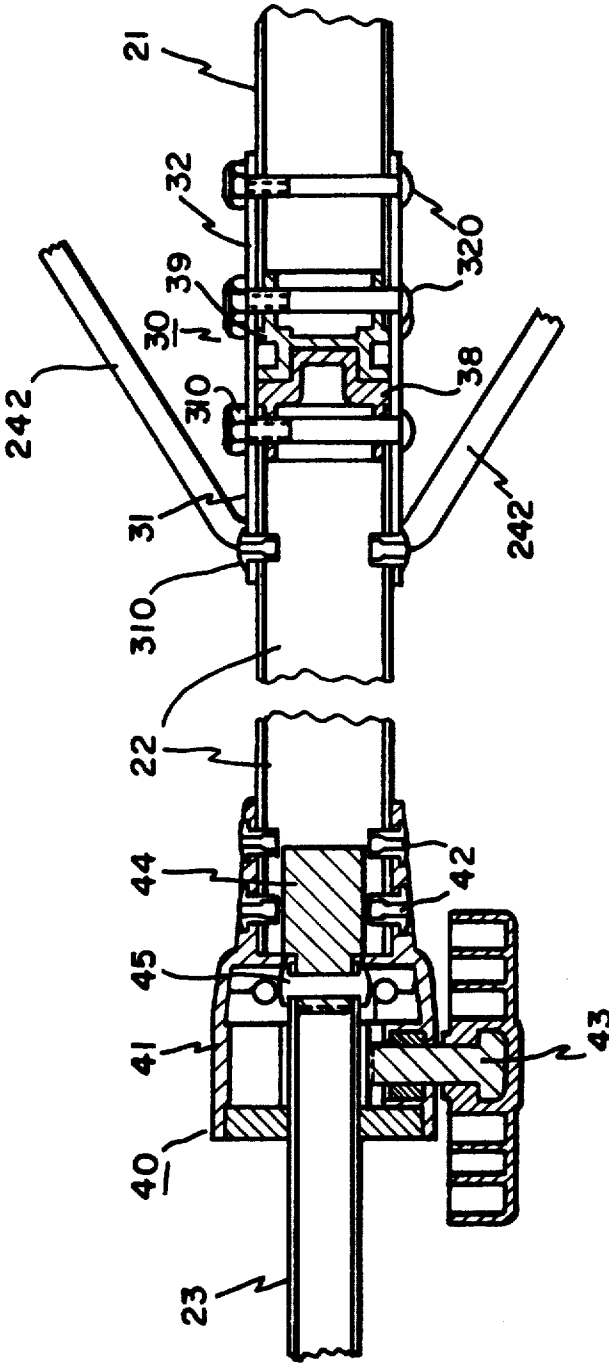


FIG. 4

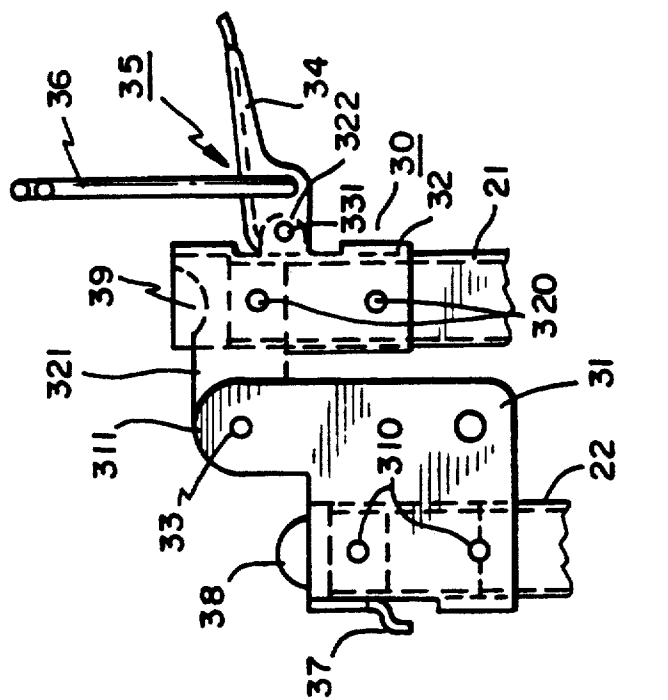


FIG. 7

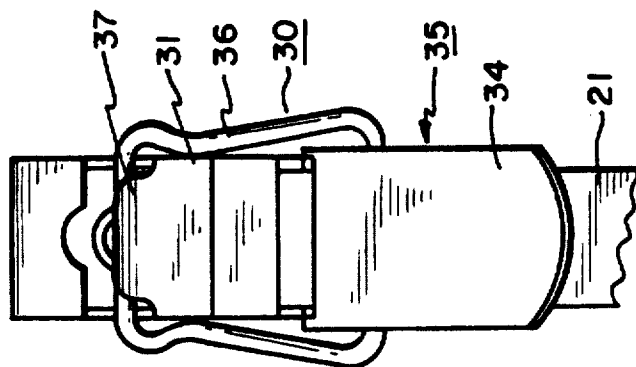


FIG. 6

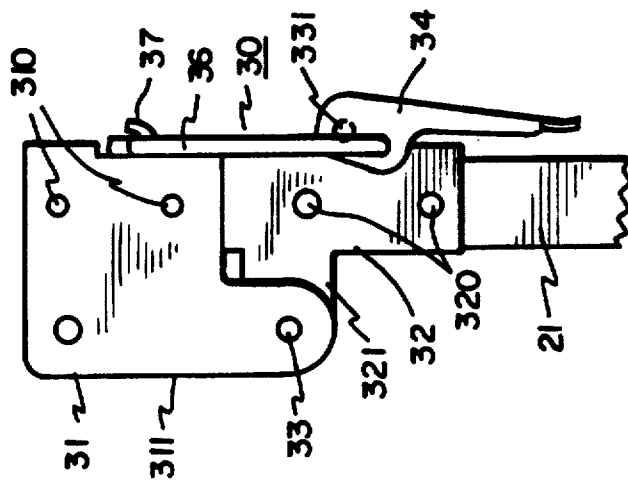


FIG. 5

FIG. 9

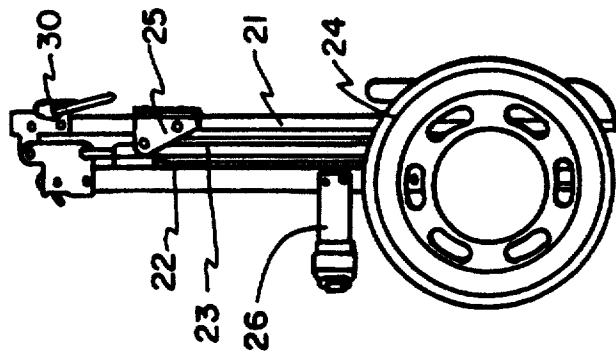
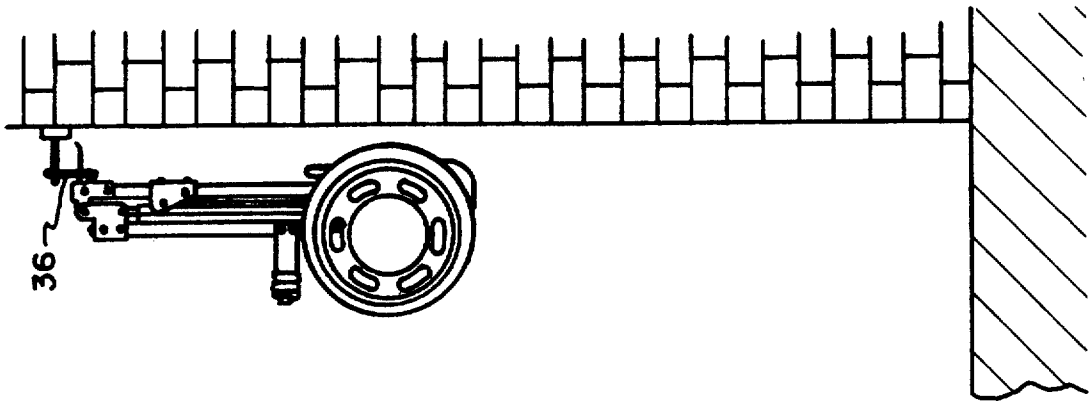


FIG. 8

## TELESCOPIC AND COLLAPSIBLE GOLF CART

Matter enclosed in heavy brackets [ ] appears in the original patent but forms no part of this reissue specification; matter printed in italics indicates the additions made by reissue.

## BACKGROUND OF THE INVENTION

This invention relates to the design and construction of a golf cart for carrying a golf bag with clubs, and particularly to the design and construction of a telescopic and collapsible golf cart.

Currently, the golfer population is growing rapidly and golf carts are widely used on golf courses.

A known golf cart, as shown in FIG. 1, mainly has an upright frame member 11 of rectangular configuration. The lower end of the frame member 11 terminates in a support member 18 which extends upwardly from the frame member 11 for supporting a golf bag at the bottom. A pair of spaced bag cradles 16, 17 having respective cradle straps for tightening the golf bag thereon, are secured to the frame member 11.

A bracket means 15 is secured to the frame member 11 at a mid portion thereof. The bracket means 15 has lateral wings pivotally connecting two side beams 13 having ends to which axles (not shown) are mounted along a fixed transverse axis. Ground supporting wheels 14 are mounted to the axles for rotation about the fixed axis. A rectangular bracket means 19 is secured to the frame member 11 at an upper end and provided with a transverse pin across two opposed side walls extending rearwardly thereof.

A pull bar 10 has an upper end terminating in a handle 101 and a lower portion pivotally mounted on the transverse pin of the bracket means 19 so that the pull bar 10 can be swung between a pull position, as shown in FIG. 1, wherein the pull bar 10 can further be locked in position by means of a slide lock 100, and a folded position wherein the pull bar 10 is disposed under the frame member 11. The slide lock 100, as shown in FIG. 1A, can be a slide body which is slidably mounted on the upper end of the frame member 11 and adapted to slide through grooves in the lower end of the pull bar 10 so as to lock the pull bar in pull position.

It is found disadvantageous that the known golf cart can only be folded into a size that is not compact enough since the distance between the spaced bag cradles 16, 17 of the frame member 11 must be long enough to retain the [gold] golf bag in a stable manner. Moreover, the cart is not adjustable in height to accommodate user preference.

## SUMMARY OF THE INVENTION

It is, therefore, an object of this invention to provide a telescopic and collapsible golf cart which is compact in telescoped and collapsed condition for facilitating packing or storage.

It is another object of this invention to provide a telescopic and collapsible golf cart which is adjustable in height to accommodate user preference.

With these objects in view, a telescopic and collapsible golf cart according to this invention includes a longitudinal frame member having ground supporting wheels, spaced bag cradles with respective cradle straps, a support frame and a handle connected thereto. The frame member is divided into three sections wherein a first section and a second section are pivot-

ally and laterally interconnected by means of a hinge means and adapted to be swung between an aligned position and a position parallel to each other. A third section is adapted to telescope within a hollow inner space of the second section of the frame member.

It is a common requirement of the golfers to have a golf cart which can be folded into a compact size and stored in a tiny locker, closet, trunk of a car or hooked in a closet, garage, house, or even conveniently carried along holiday trips by air.

## BRIEF DESCRIPTION OF THE DRAWINGS

A preferred form of the present invention is illustrated in the accompanying drawings in which:

FIG. 1 is a perspective view of a known golf cart;

FIG. 1A is an enlarged view of the slide lock on the known golf cart shown in FIG. 1;

FIG. 2 is a side elevational view of a preferred embodiment of a golf cart according to this invention and shown in an extended condition;

FIG. 3 is a top elevational view of the golf cart shown in FIG. 2;

FIG. 4 is an enlarged cross-sectional view along line A—A shown in FIG. 2;

FIG. 5 is an enlarged side elevational view of a hinge means of the present invention shown in a connected and locked condition;

FIG. 6 is an enlarged top elevational view of the hinge means shown in FIG. 5;

FIG. 7 is an enlarged side elevational view of the engaging means shown in a disconnected and folded condition;

FIG. 8 is a side elevational view of the golf cart of this invention shown in a telescoped and collapsed condition; and

FIG. 9 is a diagrammatic view of the golf cart shown telescoped, folded and further hooked for storage.

## DETAILED DESCRIPTION OF THE PREFERRED EMBODIMENT

Referring to FIGS. 2 & 3, a golf cart, which is generally indicated at 2, has a frame member which is divided into three sections 21, 22, 23. The first section 21 has a lower end terminating with a curved supporter 211 for ground support and an upper end connected with a lower end of the second section 22 through a hinge means 30. A first bag cradle 27 having cradle straps, is secured to the first section 21 at a lower end portion next to the ground supporter 211. A base plate or frame 28 has a lower end pivotally mounted on the ground supporter 211 so that the base frame 28 can be swung between an extended position, as shown in FIG. 2, perpendicular to the frame member for supporting a golf bag at a bottom thereof and a folded position, as shown in FIG. 8.

A bracket means 25 is secured to the first section 21 at an upper end portion next to the hinge means 30. The bracket means 25 has lateral wings pivotally connecting two side beams or rods 243 to the ends of which axles (not shown) are mounted along a fixed transverse axis. Ground supporting wheels 241 are mounted to the axles for rotation about the fixed axis. A pair of links 242 pivotally interconnect the hinge means 30 at the second section 22 and respective beams 243 at mid portions thereof.

The second section 22 has a hollow inner space through the length and a screw lock 40 mounted on the

upper end. A second bag cradle 26 having cradle straps and spaced from the first bag cradle 27 is secured to the second section 22 at an upper end portion next to the screw lock 40.

The third section 23 terminates with a handle 231 and is adapted to telescope within the second section 22. In addition, the third section 23 can be locked at any selected distance with respect to the second section 22 by means of the screw lock 40.

Referring to FIG. 4, the screw lock 40 includes a casing 41 secured to the upper end of the second section 22 by means of rivets 42, an inner threaded hole formed in a side wall of the casing 41 beyond the second section 22, a T-head bolt 43 having a thread adapted to be engaged with the inner thread of the hole so that the T-head bolt can be screwed inwardly through the hole, and a slider 44 connected to the lower end of the third section 23 by means of a rivet 45, sliding within the second section 22 in conjunction with the third section 23 which is to be positioned at various heights for user's preference as in usage by screwing inwardly the T-head bolt 43 of which a flat bottom end abuts against the third section 23.

The hinge means 30, as shown in FIGS. 4, 5, 6 & 7, includes a first bracket 32 secured to the upper end of the first section 21 by means of rivets or bolt and nut assemblies 320, one of which fixes a female coupler 39, a second bracket 31 secured to the lower end of the second section 22 by means of rivet and/or bolt and nut assembly 310, which fixes a male coupler 38 which, in turn, serves as a stopper for the slider 44, and a lock member generally indicated at 35. The first bracket 32 is integrally formed with a first projector 321 and a second projector 322 which are located in opposite sides thereof and extend laterally. The second bracket 31 is integrally formed with a side clevis 311 that is formed by a pair of parallel plates. A pin 33 pivotally connects the side clevis 311 of the second bracket 31 to the first projector 321 of the first bracket 32 for pivotal movement about a horizontal axis within an angle of at least 180 degrees.

The lock member 35 includes an arm 34 with one end pivotally connected to the second projector 322 by means of a pin 331 and a catch frame 36 made of wire with a lower cross beam pivotally and transversely secured in the arm 34 and spaced from the pin 331. A hook 37 is formed in a side wall of the second bracket 31 opposed to the side clevis 311.

In operation, the first section 21 and the second section 22 can be joined in aligned position through the engagement of the male and female couplers 38, 39 and further locked in position by means of the lock member 35 when the upper cross beam of the catch frame 36 is inserted in the hook 37 and the arm 34 is swung in a clockwise direction about the pin 331 to draw back the catch frame 36 downwardly. On the contrary, the arm 34 can be swung counterclockwise to release the catch frame 36 out of the hook 37, thereby permitting the second section 22 to be swung counterclockwise into a position parallel to the first section 21, as shown in FIG. 7.

In folding the golf cart 2, the third section 23 of the frame member is first telescoped into the second section 22 with the handle 231 protruding therefrom. The second section 22 is then folded into a position parallel to the first section 21 while the wheels 241 are moved by the links 242 through the beams 243 simultaneously toward the lower portion of the first section 21 and

toward each other in the same way as in a known golf cart. Finally, the base frame 28 is folded down towards the first section 21 and further retained by the straps of the first bag cradle 27 into the shape shown in FIG. 8. It will be noted that the telescoped and folded golf cart can be hooked by means of the catch frame 36, as shown in FIG. 9.

Various changes and modifications can be made in this construction without departing from the spirit of the invention or scope of the appended claims.

What is claimed is:

1. A telescopic and collapsible golf cart comprising:

- (a) a longitudinal frame member including a first section, a second section having a hollow inner space, and a third section terminating in a handle and telescopically receivable within the hollow inner space of the second section;
- (b) a base frame means pivotally connected to a lower end of the first section for swinging movement between a perpendicular position and a parallel position with respect to the first section;
- (c) a bracket means secured to the first section and including lateral wings, a side beam pivotally connected to each lateral wing, and a wheel rotatably mounted on each side beam;
- (d) a pair of spaced bag cradles secured to the first and second sections, and each cradle including strap means;
- (e) hinge means pivotally and laterally interconnecting an upper end of the first section to a lower end of the second section for permitting the first and second sections to be disposed in either a longitudinally aligned position or a parallel position with respect to each other, the hinge means including a first bracket secured to an upper end of the first section and a second bracket secured to a lower end of the second section, the first bracket including first and second projectors extending laterally from opposite sides thereof, the second bracket including a pair of parallel plates and a hook, a pin member pivotally connecting the parallel plates to the first projector, and first lock means including an arm having one end pivotally connected to the second projector and a catch frame secured to the arm for engaging the hook to lock the first and second sections in the longitudinally aligned position and for hanging the golf cart from a support means when the first and second sections are disposed in the parallel position;
- (f) a link member pivotally interconnecting each side beam to the hinge means; and
- (g) second lock means including a threaded bolt secured adjacent an upper end of the second section for selectively locking the third section in a desired telescopic position with respect to the second section.

2. A golf cart of the type having two wheels, each wheel rotatably mounted upon an axle, the cart intended to support thereon a golf bag, the cart comprising:

- a) at least first and second members; each of said members for supporting a golf bag disposed thereon;
- b) first golf bag supporting means secured to said first member and second golf bag supporting means secured to said second member;
- c) hinge means connected to and joining said first and second members such that said first and second members may be pivotally moved between a first position wherein said first and second members are disposed to

receive the golf bag upon said first and second bag supporting means, and a second position, wherein said first and second members are substantially parallel to one another;

d) first lock means coupled to one member and engageable with the other member for locking one end portion of each of said first and second members into said first position;

e) at least two beams each pivotally connected at one end to said first member and pivotally connected at the other end thereof to one of the axles; and

f) at least two links each pivotally coupled at one end to said second member and each pivotally connected at the other end thereof to one of said beams.

3. A cart as recited in claim 2 wherein upon said first and second members being in said first position, said members are longitudinally aligned.

4. A cart as recited in claim 2 further comprising handle means secured to said second member.

5. A cart as recited in claim 3 wherein said hinge means comprises a hinge; one part of said hinge connected to said first member and the other part of said hinge connected to said second member; said members in said first position, the longitudinal axes of said members are aligned and said links are connected to that part of said hinge connected to said second member.

6. A cart as recited in claim 5 wherein said ends of each of said links are connected to said hinge means.

7. A cart as recited in claim 6 further comprises a first member bracket secured to said first member; said beams each being pivotally connected to said bracket.

8. A cart as recited in claim 7 wherein said beams each comprise a pair of rods each one of which is pivotally connected at one end to said bracket and at the other end to the respective axles.

9. A cart as recited in claim 8 further comprises at least two axle brackets, each axle bracket is pivotally secured to said first and second rods for connecting said rods to the wheels.

10. A cart as recited in claim 9 wherein each pair of said first and second rods are retained in substantially parallel relationship to one another by said first member bracket and axle bracket.

11. A cart as recited in claim 10 wherein each pair of said rods being pivotally secured to said first member bracket.

12. A cart as recited in claim 11 wherein each of said first rods of each beam is disposed between each of said second rods of each beam and said hinge means; each said link is connected to one of said second rods.

13. A cart as recited in claim 12 wherein said first and second members each have a substantially rectangular

cross-section and said links are disposed on substantially opposed sides of said cross-section.

14. A cart as recited in claim 13 further comprises handle means and wherein said second member is hollow; said handle means comprises a handle insertable within an end of said second member.

15. A cart as recited in claim 14 further comprises second lock means connected to an end of said second member and engageable with said handle to permit said handle to be releasably locked and continuously positionable with respect to said second member.

16. A cart as recited in claim 15 wherein said second lock means comprises a screw bolt and said second member having a hole extending substantially perpendicular to its longitudinal axis, said screw bolt engaging said second member and said handle to releasably lock said handle in position.

17. A cart as recited in claim 16 with said cart in said second position and said handle fully telescoped within said second section, said handle being in alignment with an end of said first member.

18. A cart as recited in claim 3 further comprises handle means in cooperation with said second member.

19. A cart as recited in claim 12 wherein said second member is hollow; said handle means comprises a section inserted within an end of said second member.

20. A cart as recited in claim 19 further comprises second lock means connected to said end of said second member which receives said handle means and engageable with said handle to permit said handle to be releasably locked and continuously positionable with respect to said second member.

21. A cart as recited in claim 20 wherein said second lock means comprises a screw bolt, said second member having a hole extending substantially perpendicular to the cart longitudinal axis, said screw bolt engaging said second member and said handle to releasably lock said handle in position.

22. A cart as recited in claim 21 with said cart in said second position and said handle within said second member, said handle being between the wheels of the cart.

23. A cart as recited in claim 19 wherein with said members in said first position, the longitudinal axes of said members are aligned.

24. A cart as recited in claim 23 wherein said hinge means comprises a hinge; one part of said hinge connected to said first member and the other part of said hinge connected to said second member; said members in said first position, the longitudinal axes of said members are aligned and said links are connected to that part of said hinge connected to said second member.

\* \* \* \* \*

55

60

65