

19



Europäisches Patentamt  
European Patent Office  
Office européen des brevets



11 Publication number:

**0 637 671 A2**

12

**EUROPEAN PATENT APPLICATION**

21 Application number: **94112201.2**

51 Int. Cl.<sup>6</sup>: **E05F 11/48**

22 Date of filing: **04.08.94**

30 Priority: **06.08.93 IT TP930593**

72 Inventor: **Bergesio, Giuseppe**

43 Date of publication of application:  
**08.02.95 Bulletin 95/06**

**Strada Bria, 10-E/3  
I-12042 Bra (IT)**

84 Designated Contracting States:  
**DE ES FR GB IT**

74 Representative: **Prato, Roberto et al**

71 Applicant: **ROLTRA MORSE S.p.A.**  
**Via Albenga, 9  
I-10090 Cascine Vica - Rivoli (IT)**

**Studio Torta,  
Via Viotti 9  
I-10121 Torino (IT)**

54 **Terminal element for a window regulator channel.**

57 A terminal element (13) for the channel (3) of a window regulating device (1) including a main guide body (12) for supporting a slide (4) with window connecting means (18), and a cable activating device for moving the slide (4) along the guide body (12); the terminal element (13) presenting an integral

wall (45) with a curved portion (47) for sliding support of the cable (6); a slot (37) for snap-on connection of a tab (39) on an end portion (29) of the guide body (12); and a conduit (66) for housing in fixed manner one end of a sheath (19) in turn housing the cable (6).

**EP 0 637 671 A2**

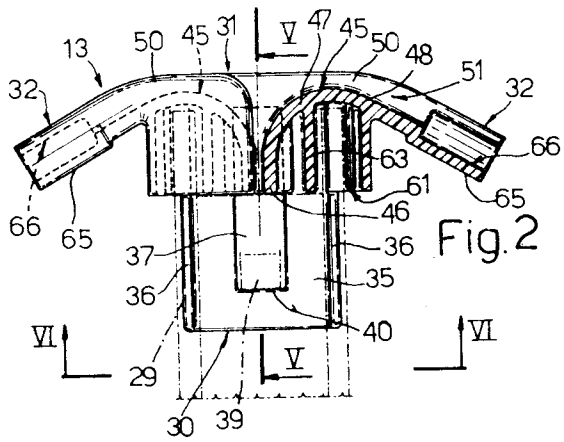
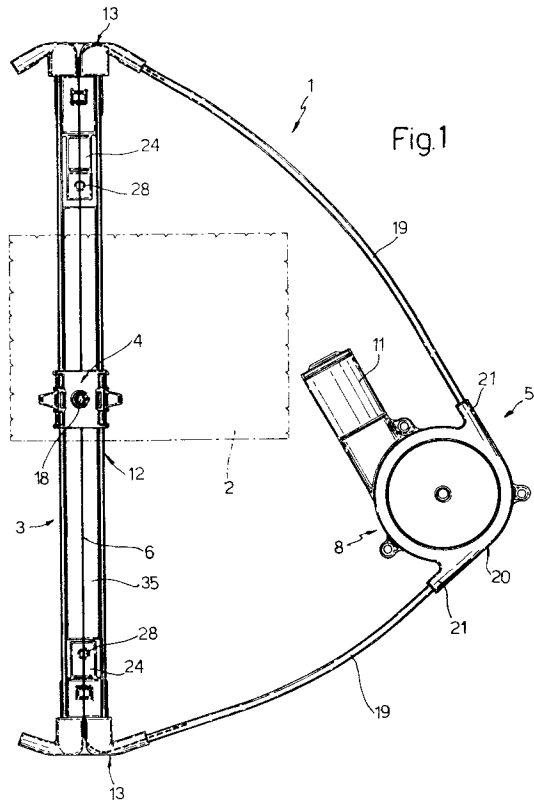

The present invention relates to a terminal element for a window regulator channel, preferably for vehicles.

More specifically, the present invention relates to a window regulator of the type comprising a channel, a slide connected to a sliding window with which it runs along the channel, and a slide activating device; the activating device comprising a cable connected to the slide and extending along at least part of a loop path; and provision being made for an actuator assembly connected to the cable for moving it axially along said path, and at least one sheath portion for a corresponding portion of the cable and extending between fixed points of said path.

The channel normally comprises a main body made of sheet metal and fitted to a frame normally consisting of a portion of the vehicle door. The ends of the main body of the channel are fitted with terminal elements for arresting the slide, and roller elements are provided for guiding the cable from the path along the channel into the sheaths towards the activating device.

On account of the number of elements at each end of the main body of the channel, assembly of such channels is relatively time-consuming, thus increasing the cost of the regulator as a whole.

It is an object of the present invention to provide a perfected terminal element for a window regulator channel, which is relatively straightforward and hence cheap to produce and assemble.

According to the present invention, there is provided a terminal element for the channel of a window regulator comprising a main body for supporting a slide presenting window connecting means; and a cable activating device for moving said slide along said main body; characterized in that said terminal element presents integral means for sliding support of said cable.

A non-limiting embodiment of the present invention will be described by way of example with reference to the accompanying drawings, in which:

Figure 1 shows a schematic side view of a window regulator featuring a channel with terminal elements in accordance with the present invention;

Figure 2 shows a larger-scale view of a terminal element of the Figure 1 channel;

Figure 3 shows a top plan view of the Figure 2 element;

Figure 4 shows a partially sectioned side view of the Figure 2 element;

Figures 5 and 6 show respective sections along lines V-V and VI-VI in Figure 2;

Figure 7 shows a further embodiment of the Figure 2 element.

Number 1 in Figure 1 indicates a window regulator for two-way regulation of a window 2 (shown

partly by the dotted line) of a vehicle (not shown).

Device 1 comprises a vertical channel 3; and a slide 4 connected in known and sliding manner to the curved-section main body 12 of channel 3, and in turn fitted with and supporting window 2 in known manner by means of an element 18. Slide 4 is moved both ways along channel 3 by a known cable activating device 5 comprising a cable 6 connected to and extending through slide 4 along a closed loop path; and an actuator assembly 8 in turn comprising a reversible electric motor 11 and connected to cable 6 so as to move it along said path. Cable 6 thus runs along body 12, and comes out at both ends through respective terminal elements 13 formed according to the present invention, for guiding cable 6 and which act as stops for respective ends of two sheaths 19 in which cable 6 is housed and guided along the loop path. The other ends of sheaths 19 are housed inside respective end portions 21 of a fixed body 20 of actuator assembly 8.

Main body 12, which is conveniently made of sheet metal, presents, close to the ends of a bottom wall 25, two integral portions 24 cut along three sides and bent downwards, and which present holes 28 for direct fitment to a vehicle door frame (not shown).

As shown more clearly in Figures 2 to 6, each terminal element 13 is formed in one piece, conveniently molded from plastic material, and is substantially T-shaped. More specifically, each terminal element 13 presents a first U-section portion 30 for connection to end portions 29 of body 12; a second upper central portion 31 which acts as a sliding and direction-change support for cable 6; and two lateral conduits 32 for housing in fixed manner one end of respective sheaths 19.

First portion 30 is defined by a bottom wall 35 and two perpendicular lateral walls 36, which are so sized as to house perfectly a respective U-section end portion 29 of body 12 as shown clearly in Figure 6. The bottom wall 35 of portion 30 presents a central slot 37; and the bottom wall of end portion 29 of body 12 presents a tab 39 bent outwards so as to click on to the front end wall 40 of slot 37 (Figures 4 and 5), when element 13 is fitted on to end portion 29 of body 12, and so prevent accidental withdrawal of element 13. A front end wall 41 of end portion 29 of body 12 is accordingly arrested against a vertical central front wall 43 of upper portion 31 of element 13 (Figure 5).

Symmetrically in relation to the central plane through front wall 43, upper portion 31 presents two curved walls 45 in turn presenting a first portion 46 parallel to and adjacent to said central plane, a curved intermediate portion 47, and an end portion 48 parallel to the axis of lateral conduits 32. From walls 45, concave portions 50 ex-

tend towards the upper outer portion of portion 31, to define conduits 51 for housing cable 6 which, as only one of conduits 51 is employed, as shown in Figure 1, therefore rests on one of walls 45. Portions 50 define an upper slot 53 enabling insertion of cable 6 inside conduit 51.

End portions 29 of body 12 present longer lateral walls 60 which are therefore housed in corresponding shaped portions 61 formed in upper portion 31 of element 13 and defined among other things by vertical intermediate inner walls 63 (Figure 6).

Lateral conduits 32 extend from end portions 48 and respective concave portions 50 of upper portion 31 of element 13, and define a larger-section tubular end portion 65 with a cylindrical inner cavity 66 also of a larger section and such as to house a respective end of a sheath 19. Lateral conduits 32 also present upper slot 53.

Figure 7 shows a variation of element 13, indicated 13', and presenting only one lateral conduit 32. Element 13' must therefore be produced in two forms, specular in relation to the central plane through front wall 43, for fitment to the top or bottom portion of body 12 respectively (Figure 1), whereas element 13 with two symmetrical lateral conduits 32 may be produced in one form for either assembly position.

The advantages of the channel terminal element according to the present invention will be clear from the foregoing description. By virtue of a single element acting as an end stop for slide 4 on main body 12, as a sliding and direction-change support for cable 6, and as a fixed connection for one end of sheath 19, the overall cost of channel 3 is reduced and assembly simplified and made faster by eliminating additional assembly parts.

Clearly, changes may be made to the embodiments described and illustrated herein without, however, departing from the scope of the present invention. For example, actuator assembly 8 may comprise, in known manner, a handle as opposed to an electric motor 11.

## Claims

1. A terminal element (13) for the channel (3) of a window regulator (1) comprising a main body (12) for supporting a slide (4) presenting window connecting means (18); and a cable activating device for moving said slide (4) along said main body (12); characterized in that said terminal element (13) presents integral means (45) for sliding support of said cable (6).
2. An element as claimed in Claim 1, characterized in that said integral means (45) comprise a wall portion (46, 47, 48) of said element (13).
3. An element as claimed in Claim 2, characterized in that said wall portion (47) is at least partially curved.
4. An element as claimed in one of the foregoing Claims, characterized in that it comprises integral means (37) for snap-on connection to end portions (29) of said main body (12) of said channel (3).
5. An element as claimed in Claim 4, characterized in that said snap-on connecting means comprise a slot (37) formed in said terminal element (13) and housing a tab (39) of said end portion (29).
6. An element as claimed in one of the foregoing Claims, characterized in that it comprises integral means (32) for housing in fixed manner one end of a sheath (19) housing said cable (6).
7. An element as claimed in Claim 6, characterized in that said means (32) for housing one end of said sheath (19) comprise at least one conduit portion (66).
8. An element as claimed in Claim 7, characterized in that it comprises a pair of said conduit portions (66) arranged specularly in relation to the plane of symmetry (43) of said element (13), perpendicular to the plane of said main body (12).
9. An element as claimed in one of the foregoing Claims, characterized in that it comprises a slot (53) for the insertion of said cable (6) on said integral means (45) for sliding support of said cable (6).
10. An element (13) as claimed in one of the foregoing Claims, characterized in that it is made of plastic material.
11. A window regulator channel (3), characterized in that it comprises a terminal element (13) as claimed in one of the foregoing Claims.
12. A vehicle window regulator (1), characterized in that it comprises a channel (3) as claimed in Claim 11.

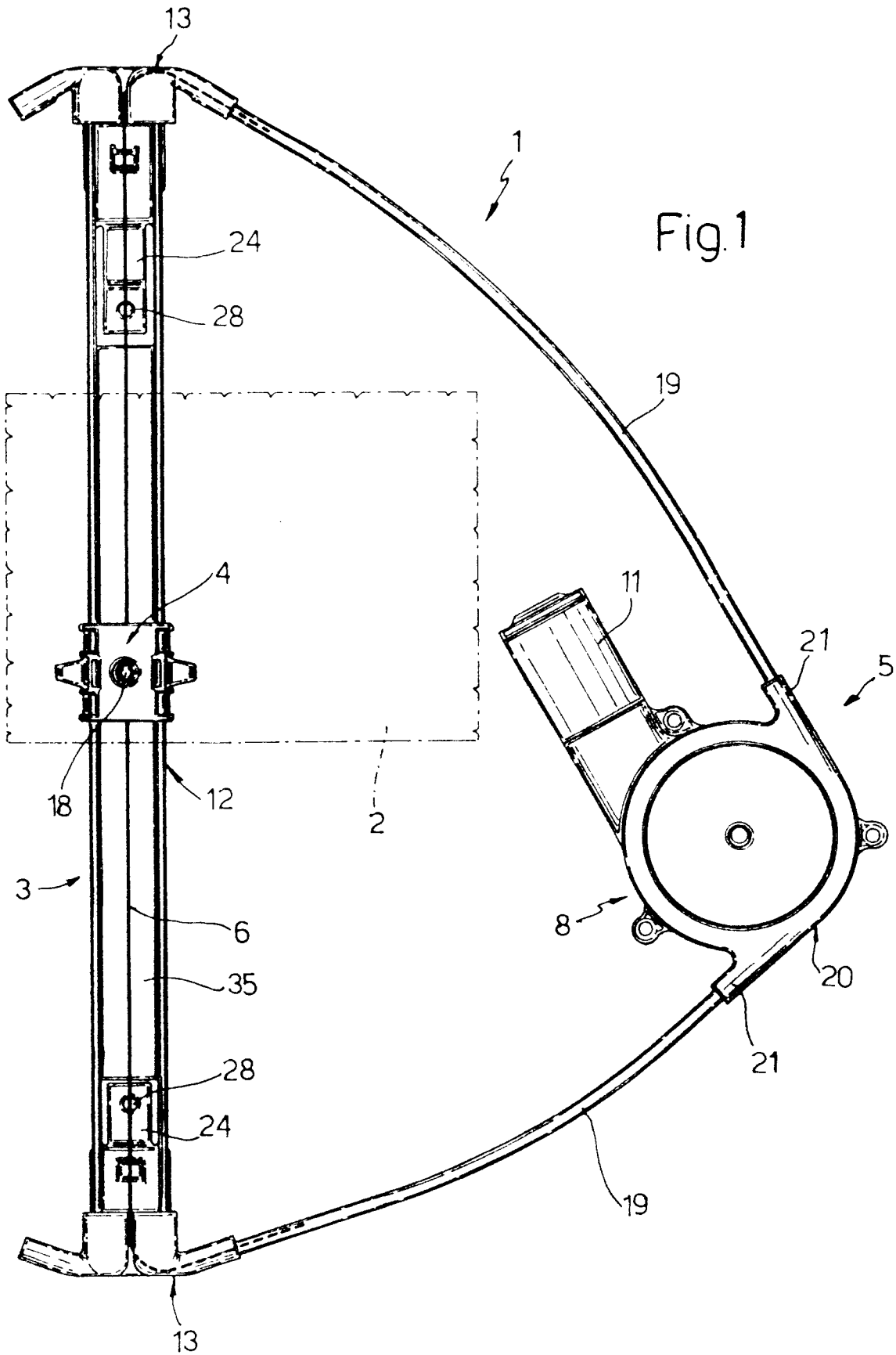

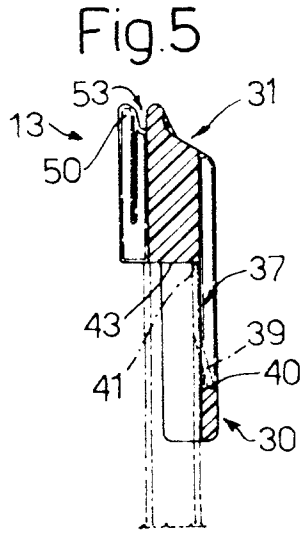

Fig. 4

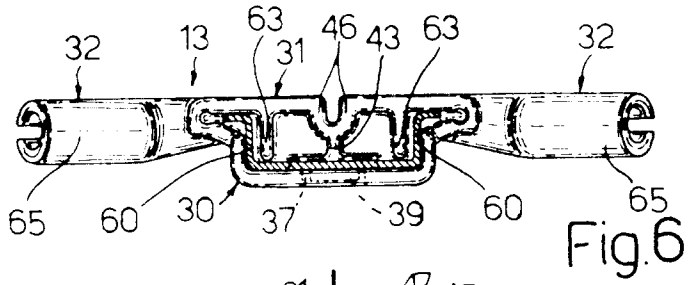
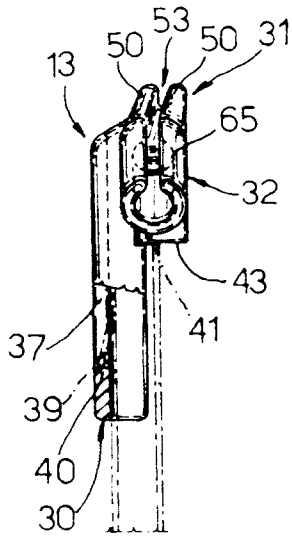

Fig. 6

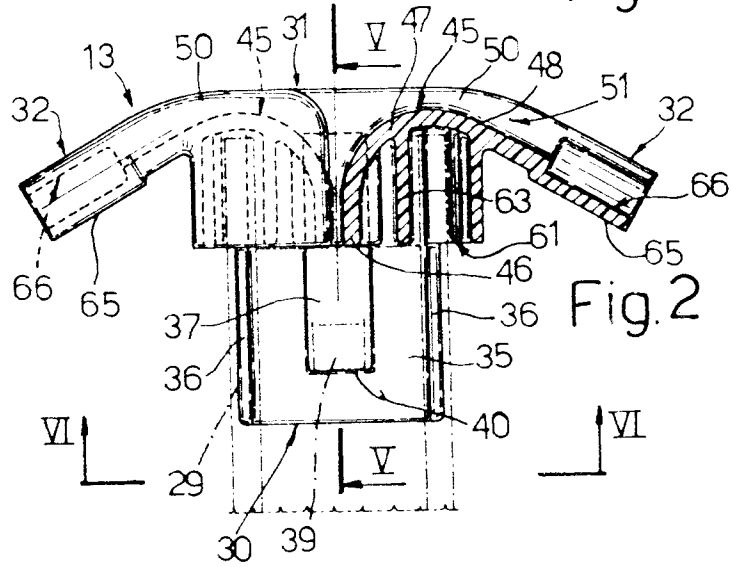

Fig. 2

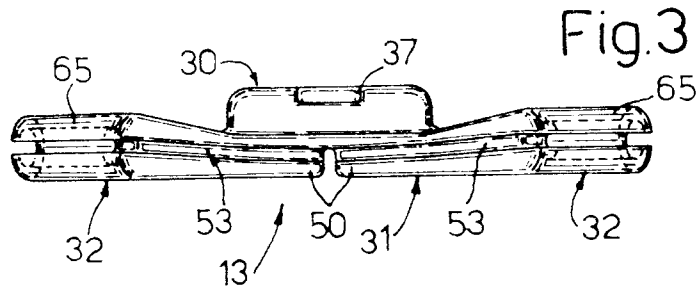

Fig. 3

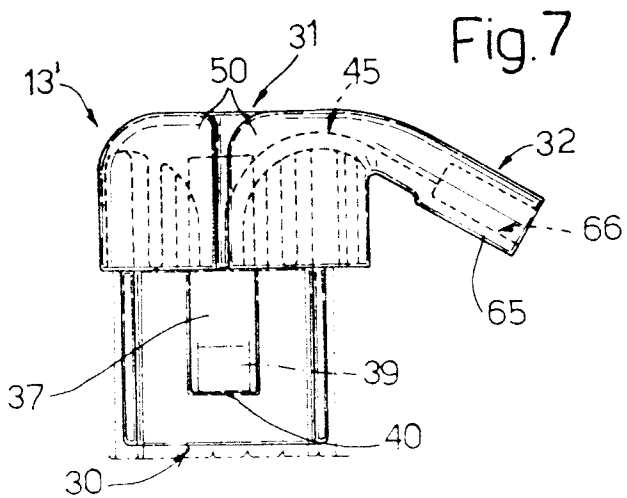

Fig. 7