

(19) AUSTRALIAN PATENT OFFICE

(54) Title
Optical fiber cable distribution frame

(51)⁶ International Patent Classification(s)
G02B 6/38 (2006.01) 6/44
G02B 6/44 (2006.01) 20060101ALI2010021
H04Q 1/14 (2006.01) 6BMAU H04Q
G02B 6/38 1/14
20060101AFI2010021 20060101ALI2010021
6BMAU G02B 6BMAU

(21) Application No: 2010200533

(22) Application Date: 2010.02.12

(43) Publication Date : 2010.03.04

(43) Publication Journal Date : 2010.03.04

(62) Divisional of:
2004300877

(71) Applicant(s)
ADC Telecommunications, Inc.

(72) Inventor(s)
Solheid, James J.; Mertesdorf, Daniel Ray; Holmberg, Matthew J.; Smith, Trevor D.

(74) Agent/Attorney
Griffith Hack, Level 3 509 St Kilda Road, Melbourne, VIC, 3004

2010200533 12 Feb 2010

2010200533

Abstract

A telecommunications connection cabinet (10) comprising: a housing (12) including an access opening (16) for accessing an interior (13) of the housing, the housing also
5 including at least one door (14) for opening and closing the access opening; an active connection area located within the interior of the housing (12), the active connection area including a plurality of telecommunications adapters (50), each telecommunications adapter being configured for coupling together two fiber optic
10 connectors such that an optical interconnection is made between the two fiber optic connectors; a fiber optic splitter located within the housing (12); a connector storage area (40) located within the housing (12), the connector storage area providing an allotted region at which to mount connector holders (37); and a plurality of connector
15 holders (110) mounted at the connector storage area, each connector holder (110) having an opening configured to receive a ferrule end of a fiber optic connector when the fiber optic connector is not in service.

FIG.1

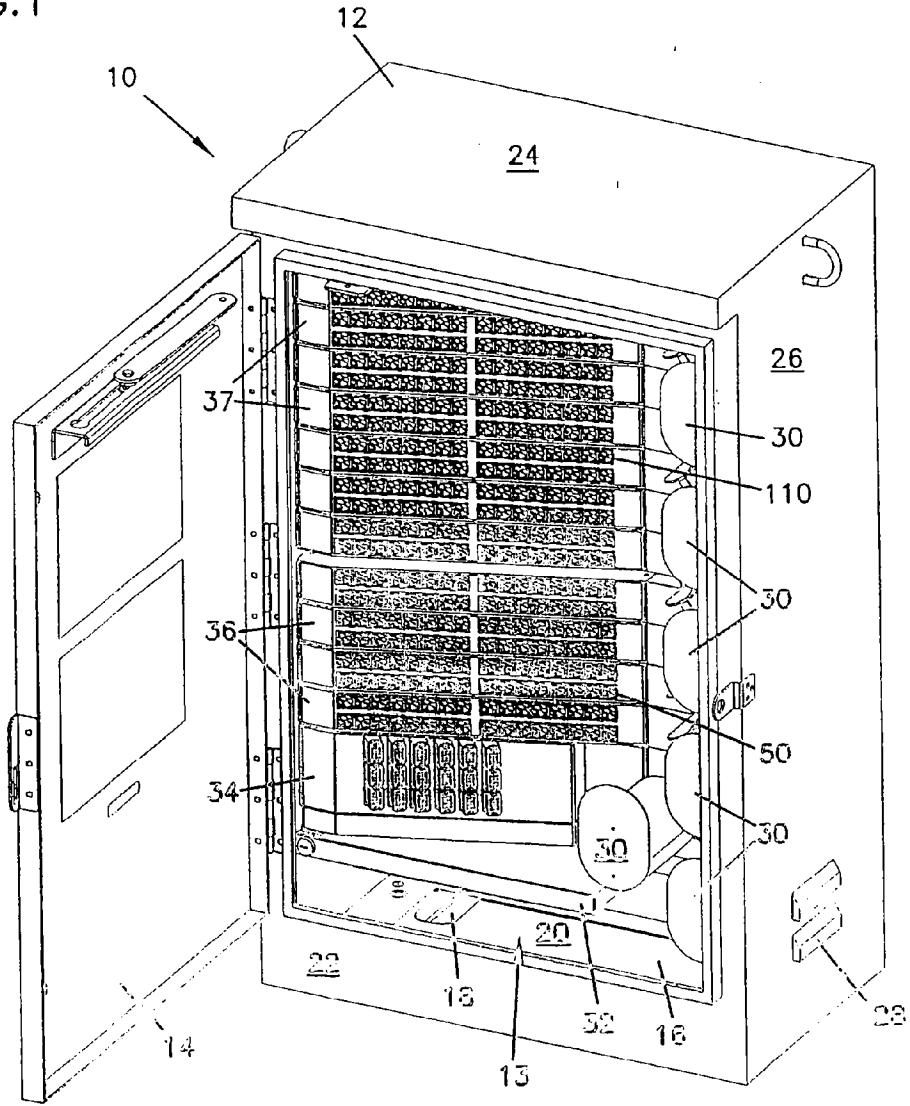

2010200533 12 Feb 2010

AUSTRALIA

Patents Act 1990

COMPLETE SPECIFICATION

Standard Patent

Applicant(s):

ADC TELECOMMUNICATIONS, INC.

Invention Title:

OPTICAL FIBER CABLE DISTRIBUTION FRAME

The following statement is a full description of this invention,
including the best method for performing it known to me/us:

TELECOMMUNICATIONS CONNECTION CABINET

Related Application

5 The present application is a divisional application of Australian patent application 2004300877 the disclosure of which is incorporated herein by reference. The present application relates to matter disclosed in that application. Most of the disclosure in Australian patent application 2004300877 is included herein to facilitate understanding of the present invention. If necessary, reference may be made to that application to gain further understanding of the present invention.

10

Field of the Invention

The present invention generally relates to cabinets for connecting telecommunications cables.

15

Background of the Invention

Installation of telecommunications equipment to support the current and potential future needs of a particular group of customers may make it desirable to install more capacity than the current customer base alone may dictate. Excess capacity may be installed to permit the easy addition of new circuits for new or existing customers. A telecommunications connection cabinet with such excess capacity may be pre-
20 configured at a fabrication facility and installed in the field to include more circuits than are necessary to provide service to the existing customers. Prior to the linkage of these surplus or future expansion circuits to customers, it is desirable to provide for storage, organization and protection of the patch cords or other connection cables within the
25 cabinet.

Such connection cables might include fiber optic patch cords terminated with fiber optic connectors. Fiber optic connectors include a polished end face, typically held by a ferrule, which permits positioning of the optical fiber held by the connector to receive and transmit signals to another optical fiber or optical light source. It is
30 desirable to keep these polished end faces as free of contaminants as possible to improve the transmission of light to and from the optical fiber held by the connector. Such contaminants which might adversely impact the transmission of light to and from the optical fiber include but are not limited to dust and finger prints.

Dust caps may be provided for connectors to protect the polished end face of the
35 optical fiber. However, when such dust caps are in place, the connector is not capable of being received in known optical fiber adapters, such as those described in U.S. Patent No. 5,317,663, and U.S. Patent No. 6,347,888. The disclosures of these patents are

incorporated herein by reference. A connector may be inserted into one of these known adapters for storage or pre-wiring of a cross-connection point, an interconnection point or some other type telecommunications switching or connection equipment with the dust cap removed. While the adapters might provide some protection from
5 contaminants to a single connector inserted into an adapter, these adapters are not as effective as a dust cap in protecting the polished end face.

It is desirable to improve the known methods and apparatus for protecting the polished end face or a fiber optic connector within telecommunications equipment.

10 **Summary of the Invention**

In accordance with an aspect of the present invention, there is provided a telecommunications connection cabinet comprising:

a housing including an access opening for accessing an interior of the housing, the housing also including at least one door for opening and closing the access opening;

15 an active connection area located within the interior of the housing, the active connection area including a plurality of telecommunications adapters, each telecommunications adapter being configured for coupling together two fiber optic connectors such that an optical interconnection is made between the two fiber optic connectors;

20 a fiber optic splitter located within the housing;

a connector storage area located within the housing, the connector storage area providing an allotted region at which to mount connector holders; and

a plurality of connector holders mounted at the connector storage area, each connector holder having an opening configured to receive a ferrule end of a fiber optic
25 connector when the fiber optic connector is not in service.

Brief Description of the Drawings

The accompanying drawings, which are incorporated in and constitute a part of the description, illustrate several aspects of the invention and together with the detailed
30 description, serve to explain the principles of the invention. A brief description of the drawings is as follows:

FIG.1 is front perspective view of a telecommunications connection cabinet according to the present invention with an access door to the front of the cabinet open.

FIG. 2 is front view of the telecommunications connection cabinet of FIG. 1
35 with illustrative cable paths.

FIG. 3 is a front view of the telecommunications connection cabinet of FIG. 1 with the adapters and connector holders removed.

FIG. 4 is a rear view of the telecommunications connection cabinet of FIG. 3.

5 FIG. 5 is a front perspective view of the rack, modules and cable management devices of the telecommunications cabinet of FIG. 1 removed from the cabinet.

FIG. 6 is a rear perspective view of the rack, modules and cable management structures of FIG. 5.

10 FIG. 7 is a front view of the rack, modules and cable management structures of FIG. 5.

FIG. 8 is a rear view of the rack, modules and cable management structures of FIG. 5.

15 FIG. 9 is a front perspective view of a splice drawer module for use with telecommunications connection cabinet of FIG. 1.

FIG. 10 is a rear perspective view of a splice drawer module for use with telecommunications connection cabinet of FIG. 1.

FIG. 11 is a front perspective view of a fanout module for use with telecommunications connection cabinet of FIG. 1.

20 FIG. 12 is a rear perspective view of a fanout module for use with telecommunications connection cabinet of FIG. 1.

FIG. 13 is a front perspective view of a chassis for the splitter module or the adapter module of telecommunications connection cabinet of FIG. 1.

25 FIG. 14 is a rear perspective view of a chassis for the splitter module or the adapter module of telecommunications connection cabinet of FIG. 1.

FIG. 15 is a first perspective view of a fiber optic connector holder according to the present invention.

FIG. 16 is a second perspective view of the fiber optic connector holder of FIG. 15.

30 FIG. 17 is a top view of the fiber optic connector holder of FIG. 15.

FIG. 18 is a bottom view of the fiber optic connector holder of FIG. 15.

FIG. 19 is a first end view of the fiber optic connector holder of FIG. 15.

FIG. 20 is a side view of the fiber optic connector holder of FIG. 15.

FIG. 21 is a second opposite end view of the fiber optic connector holder of FIG. 15.

FIG. 22 is a first perspective view of system for holder a fiber optic connector including the fiber optic connector holder of FIG. 15 with a fiber optic connector inserted.

FIG. 23 is a second perspective view of the system for holding a fiber optic connector of FIG. 22.

FIG. 24 is a top view of the system for holding a fiber optic connector of FIG. 22.

FIG. 25 is a side view of the system for holding a fiber optic connector of FIG. 22.

FIG. 26 is an end view of the system for holding a fiber optic connector of FIG. 22.

FIG. 27 is a cross-sectional view of the system for holding a fiber optic connector of FIG. 8, taken along line A-A in FIG. 25.

FIG. 28 is an exploded perspective view of the system for holding a fiber optic connector of FIG. 22.

FIG. 29 is a perspective view of the main housing of the fiber optic connector holder of FIG. 15.

FIG. 30 is a first perspective view of an inner housing of the fiber optic connector holder of FIG. 15.

FIG. 31 is a second perspective view of the inner housing of FIG. 30.

FIG. 32 is a top view of the inner housing of FIG. 30.

FIG. 33 is a side view of the inner housing of FIG. 30.

FIG. 34 is a first end view of the inner housing of FIG. 30.

FIG. 35 is a second end view of the inner housing of FIG. 30.

FIG. 36 is a first perspective view of the cover of the fiber optic connector holder of FIG. 15.

FIG. 37 is a second perspective view of the cover of FIG. 36.

FIG. 38 is a top view of the cover of FIG. 36.

FIG. 39 is a side view of the cover of FIG. 36.

FIG. 40 is a bottom view of the cover of FIG. 36.

FIG. 41 is a first end view of the cover of FIG. 36.

FIG. 42 is a second end view of the cover of FIG. 36.

5 FIG. 43 is a perspective view of the clip of the fiber optic connector holder of FIG. 29.

FIG. 44 is an end view of the clip of FIG. 43.

FIG. 45 is a side view of the clip of FIG. 43.

FIG. 46 is a bottom view of the clip of FIG. 43.

10 FIG. 47 is a top view of the fiber optic connector holder of FIG. 15 inserted within an opening in a bulkhead.

FIG. 48 is a perspective view of a bulkhead including a plurality of openings for receiving fiber optic connector adapters and the fiber optic connector holder of FIG. 15 inserted within one of the openings.

15 FIG. 49 is a perspective view of the dust cap of the fiber optic connector of FIG. 29.

FIG. 50 is a side view of the dust cap of FIG. 49.

FIG. 51 is an end view of the dust cap of FIG. 49.

FIG. 52 is a cross-sectional view of the dust cap of FIG. 49.

20

Detailed Description of the Preferred Embodiment

Reference will now be made in detail to exemplary aspects of the present invention which are illustrated in the accompanying drawings. Wherever possible, the same reference numbers will be used throughout the drawings to refer to the same or similar parts.

25

Telecommunications connection cabinets, such as cabinet 10 shown in FIG. 1, are used to permit organization and interconnection of different telecommunications infrastructure cables. A multi-strand telecommunications service cable such as an IFC or ribbon cable with multiple optical fibers, may be used to electronically or optically link widely spaced facilities. The service cable may be directed into cabinet 10 where it may be connected to a fanout module 34 and separated into individual fibers. Each of these strands may be connected to a

30

patch cord 46 which may be terminated with a fiber optic connector. The fiber optic connector of patch cord 46 (such as connector 200 described below) may then be inserted into the front of an adapter 50 mounted to an adapter module 36 within cabinet 10.

5 Adapter module 36 may also include a splitter that combines the signals from up to 32 individual patch cords 46 into a single optical fiber cable. As shown in the FIGS., there are four adapter modules 36 with splitters. As configured, cabinet 10 may have up to four optical fibers carrying the signals from up to 128 patch cords 46. These up to four optical fiber cables are directed to a splice module 10 32 mounted within cabinet 10. These up to four cables are available to splice in splice drawer 32 for communication of the signals to other downstream telecommunication equipment.

For patch cords 48 connected to circuits for which connection to downstream telecommunications equipment is anticipated but not yet required, these 15 patch cords are routed instead to a connector holder module 37. Connectors 200 terminating patch cords 48 are directed into a connector holder 110. These patch cords 48 are not optically linked to any downstream equipment and are being stored and protected for damage or contamination in connector holders 110 until needed.

Referring now to FIGS. 1 and 2, cabinet 10 includes a housing 12 20 with a top 24, opposing sides 26, a front wall 22 and a floor 20. A rear wall 23, shown in FIG. 4 below, cooperates with the top, sides, front and floor to enclose the equipment mounted within housing 12 in an interior 13. Sides 26 include vent openings 28 which are shielded to prevent rain, snow and debris entry into interior 13. Front wall 22 includes a front access opening 16 permitting access to the front 25 of the equipment mounted within interior 13. A door 14 is hinged to one side of opening 16 and closes off opening 16 to seal interior 13 from the elements when closed. A cable entry 13 in floor 20 allows the multi-strand telecommunications service cables to be fed into interior 13 and customer cables from the splice tray to exit interior 13. While only one opening 18 is shown in FIG. 1, additional openings 30 in floor 20 may be provided depending on the size and number of cables entering and exiting cabinet 10.

Mounted within interior 13 is a variety of telecommunications equipment and supporting structure. As will be described below, interior 13

includes a rack mounting structure to which this telecommunications equipment is mounted. The equipment within interior 13 includes splice module 32, fanout module 24, a plurality of adapter modules 36, and a plurality of connector holder modules 37. Adjacent this equipment are mounted a plurality of cable storage spools 30 and bend radius protectors 42. Spools 30 and radius protectors 42 cooperate to direct cables between the fronts of the different telecommunications equipment mounted within interior 13.

Within interior 13, adapter modules 36 and connector holder modules 37 include a module housing, which will be discussed below. Each of the housings for modules 36 and 37 are mounted within the internal rack mounting structure of cabinet 10. Adapter modules 36 are grouped together in an active connection stack 38 and connector holder modules 37 are grouped together in a storage stack 40. Fanout module 34 is mounted beneath active connection stack 38 as the service cable enters cabinet 10 from below through opening 18. As configured in the drawings, cabinet 10 also directs the customer cables through floors 20, so splice module 32 is located below the active connection and storage areas. If the service and/or customer cables enter cabinet 10 through an opening through or adjacent to top 24, fanout module 34 and splice module 32 may be positioned above the active connection and storage areas.

Referring now also to FIGS. 3 and 4, cabinet 10 is configured to be a front access cabinet and no provision is made for allowing access through rear wall 23. In the field, a technician would only need to access the equipment mounted within cabinet 10 through front opening 16 to connect or disconnect a particular customer's circuit. All connections between the various equipment behind the equipment in the interior 13 are not easily accessible and are anticipated to be pre-configured and cabled before cabinet 10 leaves the manufacturing facility. Alternatively, rear wall 23 could be configured with an access door if such access is desired.

Modules 34, 36 and 37 include front faces which are angled with respect to front wall 22 to improve the positioning of cables between the cable management structures (including spools 30 and radius limiters 42) and adapters and connector holders 110.

As shown in FIGS. 3 and 4, connector holders 110, adapters 50 and any splitters within modules 36 and 37 have been removed. The module housing 56 for each module 36 and 37 may be identical and will be described further below. As shown in FIGS. 1 and 2, each module 37 includes 32 connector holders in each of
5 seven connector holder modules 37. This provides a total storage capacity as configured of 224 connectors 200.

Fanout module 34 as shown in the FIGS. includes eighteen cable breakouts 54. Each cable breakout 54 allows for separation of a service cable or subunit of a service cable into a maximum of 12 fibers. This provides a maximum
10 capacity for fanout module 34 to receive up to eighteen service cables or subunits of service cables, and separate out up to 216 patch cords 46 and 48 from these service cables. This permits a connector holder in storage area 40 for each of the maximum number of patch cords 46 and 48 that may extend from fanout module 34.

Patch cords 46 and 48 may be terminated with fiber optic connectors
15 such as connector 200 shown in FIGS. 22 through 28, below. Optical fiber within these cables may be terminated at a polished end face held by a ferrule 202 in connector 200, as is well known in the art and shown in U.S. Patent No. 5,317,663, incorporated herein by reference. These polished end faces and ferrules 202 need to be stored and protected until needed for connecting to other fiber optic cables or
20 optical signal equipment.

Often a dust cap 204 may be placed about ferrule 202 and the polished end face of the optical fiber to protect the polished end face from contamination from dust, fingerprints or other items which might degrade optical signal transmission. While it is known to store these in known optical fiber adapters
25 until the fiber within the attached cable is needed to connect to another fiber optic cable to optical signal equipment, such storage is less than ideal as adapters do not seal the polished end face from contamination as well as dust cap 204 securely fit and held about ferrule 202 of connector 200. Known adapters do not permit insertion of connector 200 which still has dust cap 204 in place about ferrule 202
30 and the polished end face of the cable.

Referring now to FIGS. 15 and 16, connector holder 110 includes a main housing 112 defining an interior cavity 114. An open end 118 permits insertion of a connector 200 into cavity 114 while an opposite opening 116 permits

dust cap 204 to protrude from connector holder 10. A clip 120 is positioned about main housing 112 and includes a pair of spring mounting clips 122. A pair of flanges 124 extends from opposing sides 126 of main housing 112 adjacent spring clips 122. Clips 122 and flanges 124 cooperate to releasably mount holder 10 to an opening in a bulkhead as is shown below.

Main housing 112 also includes a bottom 130 with a keyway 128 to receive a keyed extension of connector 200 to consistently orient connector 200 for insertion into cavity 114. Opposite bottom 130 is an open top closed by a cover 132. This is shown in more detail in FIG. 26, below. FIGS. 17 through 21 provide additional views of connector holder 110.

Referring now to FIGS. 22 through 27, connector 110 is shown with connector 200 positioned within cavity 118. Dust cap 204 extends from opening 116 of connector holder 110 while connector 200 is inserted through open end 114.

Referring now to FIGS. 27 and 28, connector holder 110 further includes an inner housing 134 with a pair of opposing releasable catches 136 and an opening 138 sized to receive dust cap 204. Inner housing 134 is positioned within main housing 112 through an open top 140 with opening 138 adjacent opening 116 and catches 136 adjacent open end 114. Cover 132 is then positioned within open top 140 and clip 120 placed about cover 132 and main housing 112. Cover 132 may be sealed within open top 140 by gluing, ultrasonic welding or a variety of known fastening techniques. Connector 200 includes a pair of opposing recesses 206 which receive catches 136 when connector 200 is inserted within holder 110.

As shown, connector 200 and holder 110 are SC style. Connector 200 and holder 110 may conform to other styles and formats of electrical connectors and adapters without straying from the spirit of the present invention.

Referring now to FIG. 29, main housing 112 also includes a slot 142 along both sides of cavity 114 to receiving and positioning a flange of inner housing 134 within cavity 114. A recess 144 is provided along sides 126 to receive clip 120. Open top 140 includes a ledge 146 upon which cover 132 is positioned to close cavity 114. An outer bulkhead 168 forms a portion of opening 116. An inner bulkhead 145 is positioned spaced apart from outer bulkhead 168 and these bulkheads cooperate to define slot 142. Between bulkheads 145 and 168 is a positioning surface 143 defining the bottom of slot 142.

Referring now to FIGS. 30 to 35, inner housing 134 includes a pair of clip arms 148 extending from a cross piece 150. Opening 138 for receiving dust cap 204 of connector 200 is in cross piece 150. Catches 136 are at the end of clip arms 148 opposite cross piece 150. Cross piece 150 includes a pair of flanges 152 which are received in slots 142 in main housing 112. As shown in FIG. 32, catches 136 include a ramped portion 154 which is engaged by connector 200 as connector 200 is inserted within cavity 114 through open end 118 of connector holder 110. Clip arms 148 are deflected outward allowing connector 200 to pass between catches 136. When connector 200 is fully inserted within cavity 114 (as shown in FIG. 27) catches 136 are received within recesses 206 and a retaining surface 156 of each catch 136 holds connector 200 within cavity 114.

Inner housing 134 is configured to permit insertion within slots 142 of cavity 114 of main housing 112 in either of two orientations. A pair of edges 166 of cross piece 150 properly position inner housing within cavity 114 with regard to cover 132 and main housing 112 so that opening 138 is aligned to receive dust cap 204.

Referring now to FIGS. 36 to 42, cover 132 includes a recess 158 for receiving clip 120 along an outer surface 168. Also in outer surface 168 is a recess 172 for receiving indicia. Along an inner surface 170 are formed a pair of edges 164 configured to be received upon ledges 146 of main housing 112. Extending from inner surface 170 is an outer flange 160 which cooperates with bulkhead 168 within main housing 112 to define opening 116. Also extending from inner surface 170 is an inner flange 162 which is spaced apart from outer flange 160 to form a slot 163. Slot 163 cooperates within slot 142 of main housing 112 to receive flanges 152 of inner housing 134.

At the top of slot 163 is a positioning surface 161 which cooperates with one of edges 166 of inner housing 134 to position inner housing 134 within cavity 114 so that opening 138 of inner housing 134 is aligned with opening 116. When assembled as connector holder 110, positioning surface 143 of main housing 112 and positioning surface 161 of cover 132 cooperate to engage both edges 166 of inner housing 134. Slot 142 of main housing 112 and slot 163 of cover 132 cooperate to capture flanges 152 of inner housing 134.

Referring now to FIGS. 43 to 46, clip 120 includes a cross piece 174 and a pair of opposing sides 176. Spring clips 122 are formed in sides 176. Sides 176 are received within recesses 144 of main housing 112 and cross piece 174 is received within recess 158 of cover 132. It is anticipated that clip 120 will be made
5 of a resilient deformable metal to facilitate insertion and removal from an opening in a bulkhead. Spring clips 122 each include an end 178 and a ramped surface 180.

FIGS. 47 and 48 shows fiber optic connector holder 110 inserted within an opening 184 in a bulkhead 182. Bulkhead 182 may be part of a piece of telecommunications switching equipment such as a panel for making a plurality of
10 connections between optical fiber cables including a plurality of openings 84 for adapters, as shown in FIG. 48, or in connector holder module 37. Alternatively, bulkhead 182 may include only a single opening 184 where only a single fiber optic connector holder 110 is needed.

Open end 118 of connector holder 110 is inserted through opening
15 184 until a pair of sides 186 of opening 184 engage ramped surfaces 180 of spring clips 122. Continued insertion of connector holder 110 will cause bulkhead sides 186 to deflect spring clips 122 inward toward sides 126. Bulkhead sides 186 will eventually pass beyond ends 178 of spring clips 122. Spring clips 122 will then spring back as shown in FIG. 48, capturing bulkhead sides 186 between ends 178
20 and flanges 124. Connector holder 110 may be removed from opening 184 by compressing spring clips 122 and removing in a direction opposite the insertion described above.

Alternatively, flanges 124 may be configured to include a fastener opening so that connector holder 110 can be mounted within opening 184 by
25 removable fasteners.

It is anticipated that openings 184 for mounting adapters and connector holders may be included in sliding adapter packs, such as described in commonly-owned U.S. Patent No. 5,497,444. The disclosure of this patent is
30 incorporated herein by reference.

Referring now to FIGS. 49 through 52, dust cap 204 includes a
30 central opening 208 to receive ferrule 202 when ferrule 202 is inserted through open end 210. Opposite open end 210 is closed end 212 which includes knurling 214 to provide better grip for removing dust cap 204. Central opening 208 fits about

ferrule 202 to provide a seal about ferrule 202 and to hold dust cap to connector 200. Due to the reduction of air volume within central opening 208 when ferrule 202 is inserted (see FIG. 27), one or more helix shaped recesses 216 are provided within central opening 208 along inner walls 218. Recesses 216 extend from adjacent
5 closed end 212 to open end 210. Recesses 216 are small enough prevent entry of unwanted contaminants and still permit air displaced within central opening 208 to be expelled when ferrule 202 is inserted so that dust cap 204 may be fully seat to connector 200. Recesses 216 also allow air to pass into central opening 208 when
10 dust cap 204 is withdrawn from ferrule 202. The shape of each recess 216 is also designed to allow passage of air into and out of central opening 208 when dust cap 204 is removed or placed on ferrule 202 while inhibiting the passage of contaminants along the same path.

Referring now to FIGS. 5 through 8, cabinet 10 is shown without housing 12. A pair of vertical supports 51 and 52 adjacent sides 26 of housing 12
15 provide mounting locations for the equipment mounted in cabinet 10. A cable management panel 58 is mounted to vertical support 51, and a plurality of cable spools 30 are mounted to panel 58. Bend radius protectors 42 are mounted to each module housing 56 adjacent panel 58 and provide bend radius protection for cables
46 and 48 being directed from spools 30 to modules 36 or 37.

20 Mounted to the rear of fanout module 34 is a cable clamp 60 for securing the service cable after it enters cabinet 10 through opening 18 in bottom 20. From clamp 60, the service cable, sub-units of the service cable or smaller bundles of optical fibers may enter fanout module 34 through rear opening 62. In addition to
25 spools 30 mounted to panel 58, another spool 30 is mounted to the front of fanout module 34 to provide bend radius protection and direct patch cords 46 and 48 from cable breakouts 54 into cable spools 30 of panel 58 and radius protectors 42 of modules 36 and 37.

Referring now to FIGS. 9 and 10, splice module 32 includes a splice
30 drawer 64 slidably mounted within a housing 66. Splice module housing 66 includes a pair of mounting flanges 72 and 74 for mounting splice module 32 to panel 58 and vertical support 52. A locking drawer latch 68 is included in drawer 64 to prevent unwanted or accidental access to the splices within splice module 32. A

rear opening 70 is provided to permit cables from modules 36 to enter housing 66 and be spliced in drawer 64.

Referring now to FIGS. 11 and 12, fanout module 34 includes a front face to which are mounted the eighteen cable breakouts 54. Fanout module 34 also includes a flange 72 for mounting to panel 58 and a flange 74 for mounting to vertical support 52.

Referring now to FIGS. 13 and 14, module housing 56 provides the basic shell for both adapter module 36 and connector holder module 37. Housing 56 includes a front face 84 with four openings 84. Openings 84 are sized and configured to receive up to eight adapters 50 or connector holders 110, so that a total of thirty-two patch cords 46 or 48 can be received. These adapters 50 or connector holders 110 may be held within opening 84 by a retainer clip such as that disclosed in commonly-owned U.S. Patent No. 5,214,735, the disclosure of which is incorporated herein by reference. Module housing 56 also defines an interior space 86 with a cable exit 80 in a side wall 78. When module housing 56 is used for an adapter module 36, each adapter 50 mounted in openings 84 may have a connector 200 inserted into a rear side that will be optically linked with a connector 200 of patch cord 46 inserted into a front side. These rear connectors 200 may terminate fiber optic cables which may then extend through cable exit 80.

Alternatively, adapter module 36 may include a splitter within interior 86. Then, the connectors 200 attached to the rear of each adapter 50 would be optically connected to the splitter. The splitter would then combine the signals from each of the adapters 50 for a given module 36 into a single optical fiber cable which may then be directed out of module 36 through cable exit 80 and to rear opening 70 of splice module 32. Within splice module 32, each of the cables carrying the combined signals from the patch cords 46 connected to up to thirty-two adapters of a module 36 could be spliced into another cable for distribution of the signals to downstream equipment or customers.

As shown in the FIGS., cabinet 10 is configured for front access only, as no provision is made for an access opening through rear wall 23. Other configurations of housing 12 for cabinet 10 are contemplated, which may include providing additional access into interior 13. A preferred method of connecting a

fiber optic service cable in cabinet 10 reduces the need access to the rear of the equipment mounted within housing 12.

To connect a service cable within cabinet 10, the service cable is fed into cabinet 10 through opening 18 in bottom 20. The service cable is directed into a space between the equipment mounted to vertical supports 51 and 52 and rear wall 23 and then clamped to the rear of fanout module 34 at clamp 60. From clamp 60, the cable may be broken out into sub-units and directed through opening 62 into an interior 61 of fanout module 34. Within interior 61, the sub-units of cable are further broken down to the individual fibers which are lead to cable breakouts 54 where they are passed out of interior 61 and preferably up-jacketed to standard patch cords 46 or 48 terminated with connectors 200. Patch cords 46 and 48 are anticipated to standard size patch cords such as 1.7 mm, 2.0 mm, or otherwise appropriately sized for routing within cabinet 10.

From the breakouts 54, patch cords 46 and 48 are lead over spool 30 mounted to fanout module 34 and to the spools 30 mounted to panel 58. From these spools, the patch cords 46 and 48 are led past radius protectors 42 and connectors 200 inserted within an adapter 50 and a connector holder 110, respectively. Patch cords 46, as described above, are optically linked through adapter 50 and possibly a splitter within interior 86 of adapter module 36 to splice module 32 and then to downstream equipment. As described above, patch cords 48 are stored for future use in connector holders 110 with dust cap 104 in place to protect the polished end faces from damage or contamination.

When one of the stored or inactive patch cords 48 is needed for connection to downstream equipment, for instance when a new customer requests service or an existing customer needs to expand service, the desired inactive patch cord 48 is removed from connector holder 110. Dust cap 104 is removed from ferrule 102 of connector 200 and patch cord 48 is partially removed from spools 30 mounted to panel 58. This patch cord is then rerouted so that its connector 200 is adjacent the desired adapter 50 for connecting to downstream equipment. At this point, the former inactive patch cord 48 has become an active patch cord 46 and is inserted into the appropriate adapter 50. An active patch cord 46 may be converted to an inactive patch cord 48 by a reversal of the above process when a previously required circuit is no longer needed by a customer or other downstream equipment.

By configuring cabinet 10 as described above, only front access through access opening 16 is necessary in the field for a technician to connect a circuit for a new customer or an existing customer or to take a circuit out of service.

5 The above specification, examples and data provide a complete description of the manufacture and use of the composition of the invention. Since many embodiments of the invention can be made without departing from the spirit and scope of the invention, the invention resides in the claims hereinafter appended.

10 In the claims which follow and in the preceding description of the invention, except where the context requires otherwise due to express language or necessary implication, the word "comprise" or variations such as "comprises" or "comprising" is used in an inclusive sense, i.e. to specify the presence of the stated features but not to preclude the presence or addition of further features in various embodiments of the invention.

15 It is to be understood that, if any prior art publication is referred to herein, such reference does not constitute an admission that the publication forms a part of the common general knowledge in the art, in Australia or any other country.

THE CLAIMS DEFINING THE INVENTION ARE AS FOLLOWS:

1. A telecommunications connection cabinet comprising:
a housing including an access opening for accessing an interior of the housing,
5 the housing also including at least one door for opening and closing the access opening;
an active connection area located within the interior of the housing, the active
connection area including a plurality of telecommunications adapters, each
telecommunications adapter being configured for coupling together two fiber optic
10 connectors such that an optical interconnection is made between the two fiber optic
connectors;
a fiber optic splitter located within the housing;
a connector storage area located within the housing, the connector storage area
providing an allotted region at which to mount connector holders; and
a plurality of connector holders mounted at the connector storage area, each
15 connector holder having an opening configured to receive a ferrule end of a fiber optic
connector when the fiber optic connector is not in service.
2. The telecommunications connection cabinet of claim 1, wherein each fiber optic
20 connector is configured to receive a dust cap over the ferrule end of the connector.
3. The telecommunications connection cabinet of claim 2, wherein each fiber optic
connector is configured to receive the dust cap over the ferrule end of the connector
when the connector is mounted at the connector storage area.
- 25 4. The telecommunications connection cabinet of claim 1, wherein the connector
holders lacks means for coupling together two fiber optic connectors such that an
optical interconnection is made between the two fiber optic connectors.
5. The telecommunications connection cabinet of claim 1, further comprising a
30 plurality of fiber optic cords, each fiber optic cord having an end that terminates at a
fiber optic connector held by one of the connector holders.
6. The telecommunications connection cabinet of claim 1, further comprising a
35 bulkhead located within the interior of the housing, the bulkhead including openings
sized to fit the telecommunications adapters and openings sized to fit the connector
holders, wherein the openings sized to fit the connector holders have the same footprint
as the openings sized to fit the telecommunications adapters.

7. The telecommunications connection cabinet of claim 1, wherein each of the connector holders includes at least one resilient connector holding member that flexes when a fiber optic connector is inserted into the respective connector holder.

5

8. The telecommunications connection cabinet of claim 7, wherein the at least one resilient connector holding member engages an exterior of the fiber optic connector.

9. The telecommunications connection cabinet of claim 8, wherein the at least one
10 resilient connector holding member includes a pair of clip arms.

10. A telecommunications connection cabinet as claimed in any one of the preceding claims, and substantially as herein described with reference to the accompanying drawings.

FIG.1

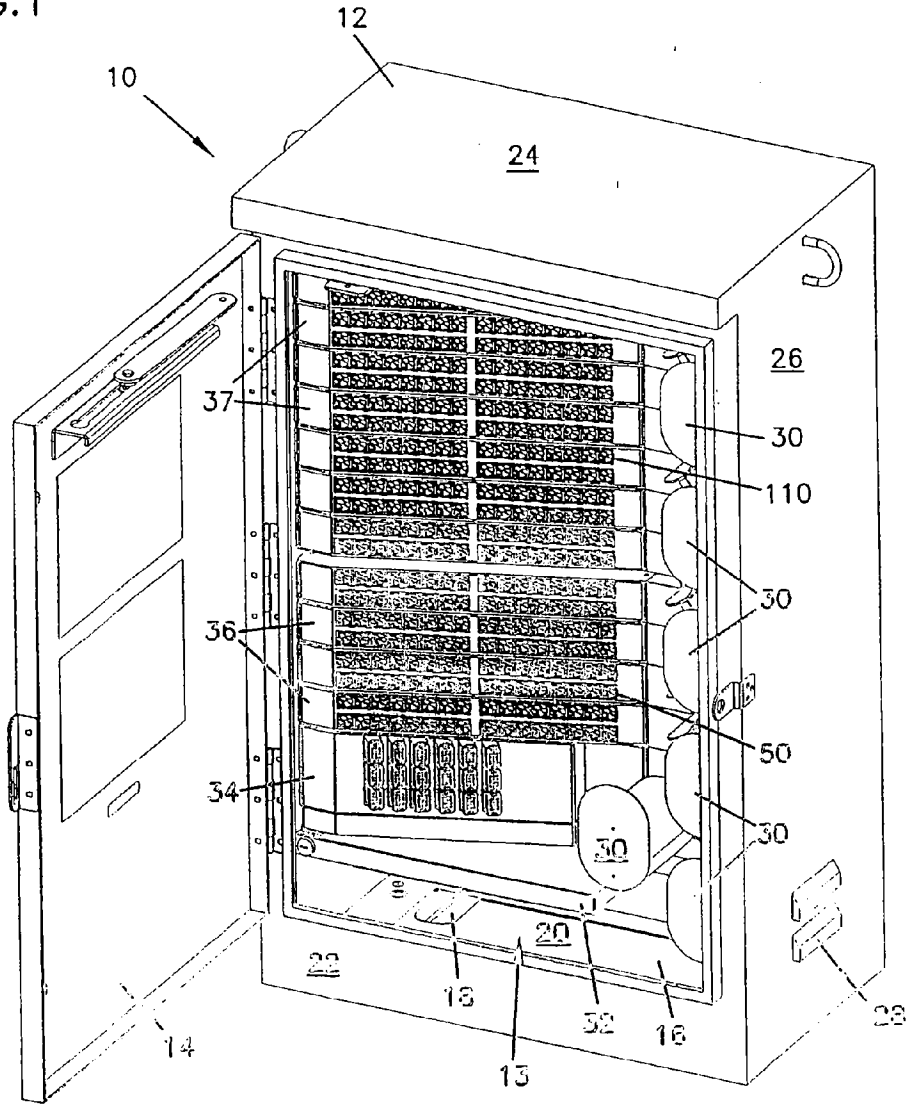
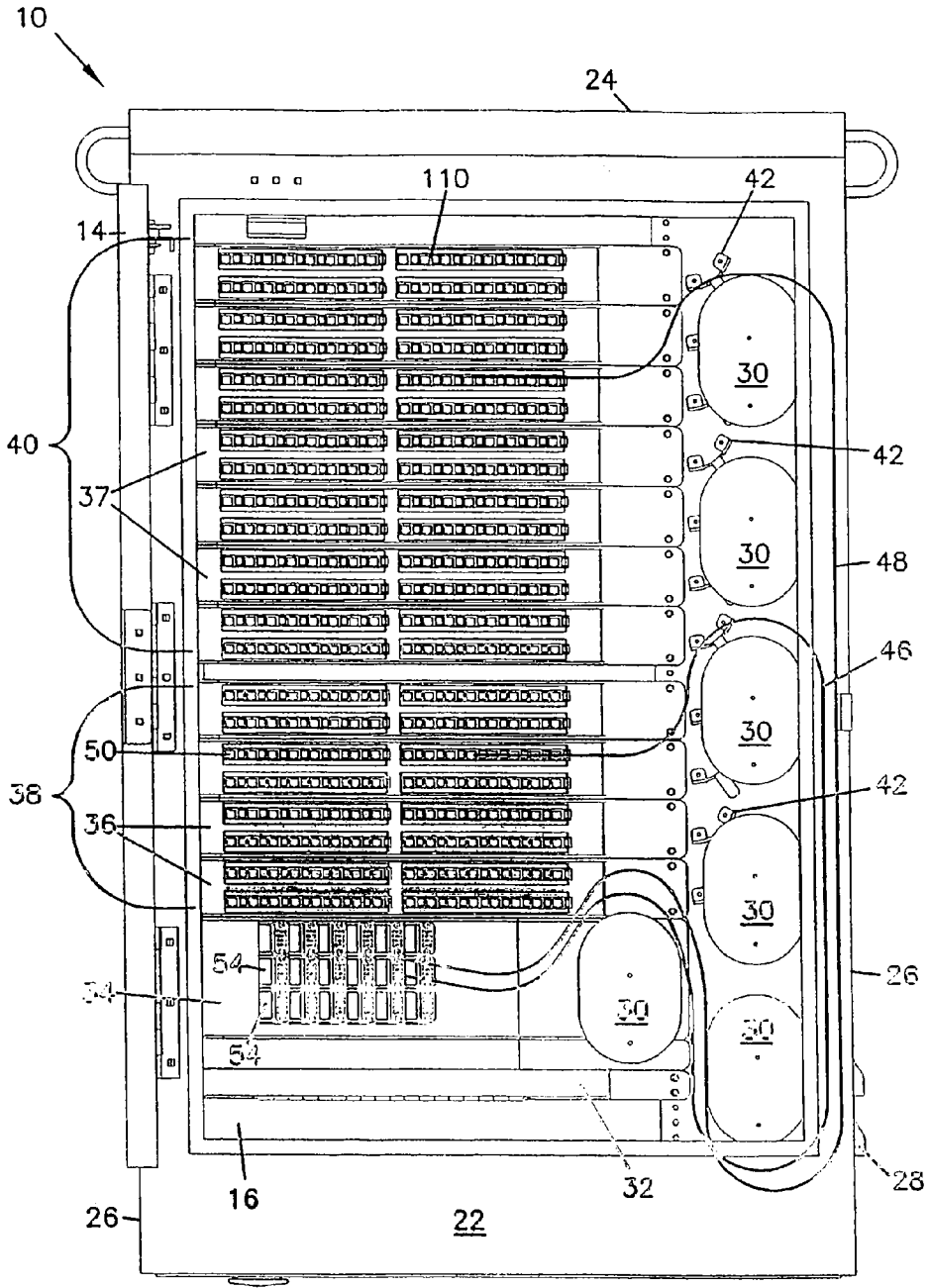

FIG.2



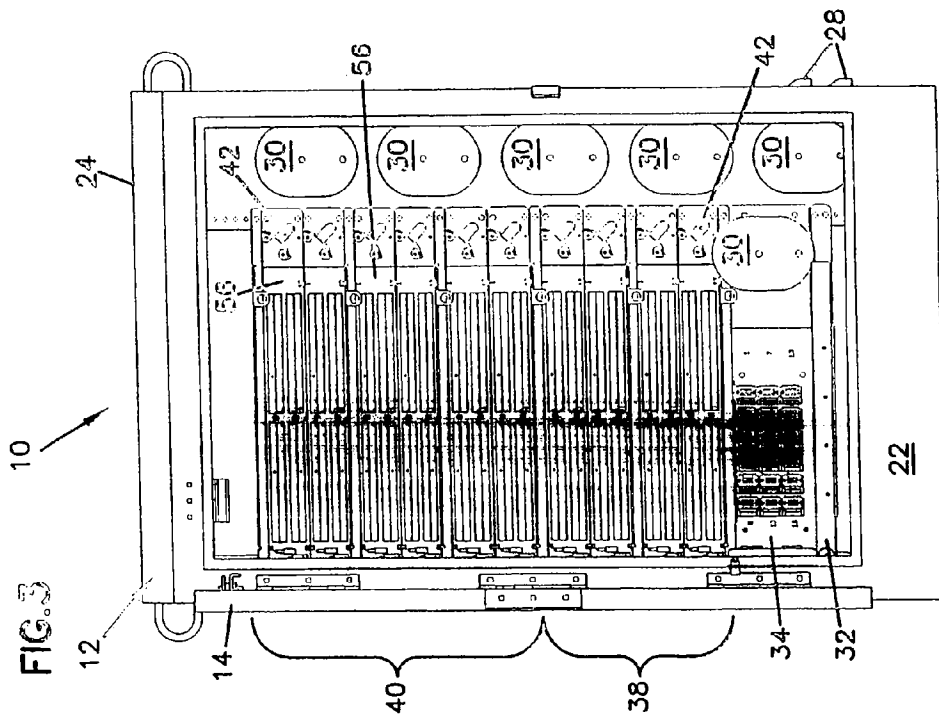
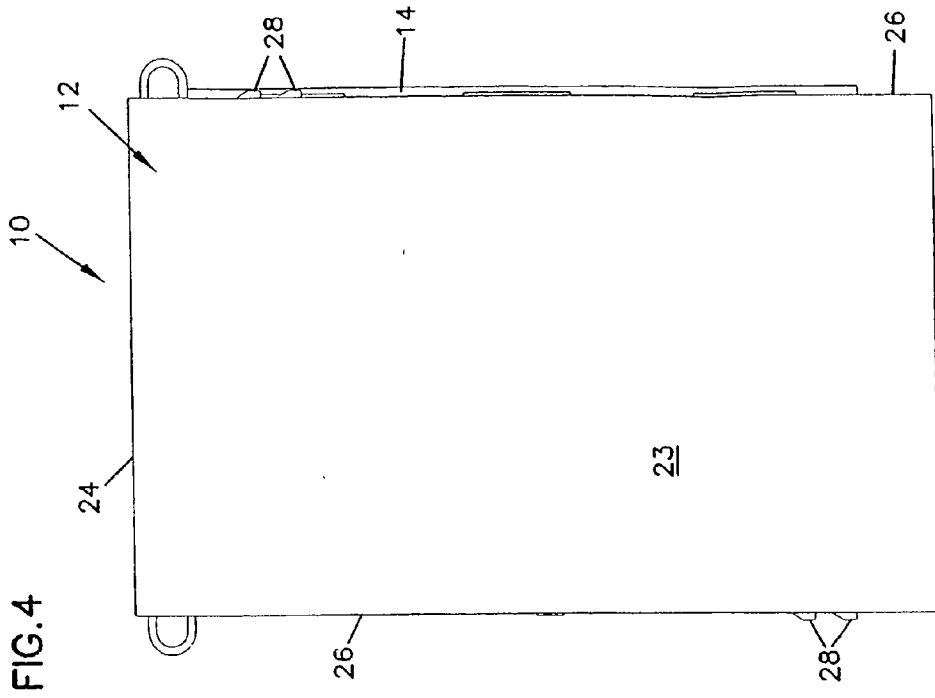

FIG.5

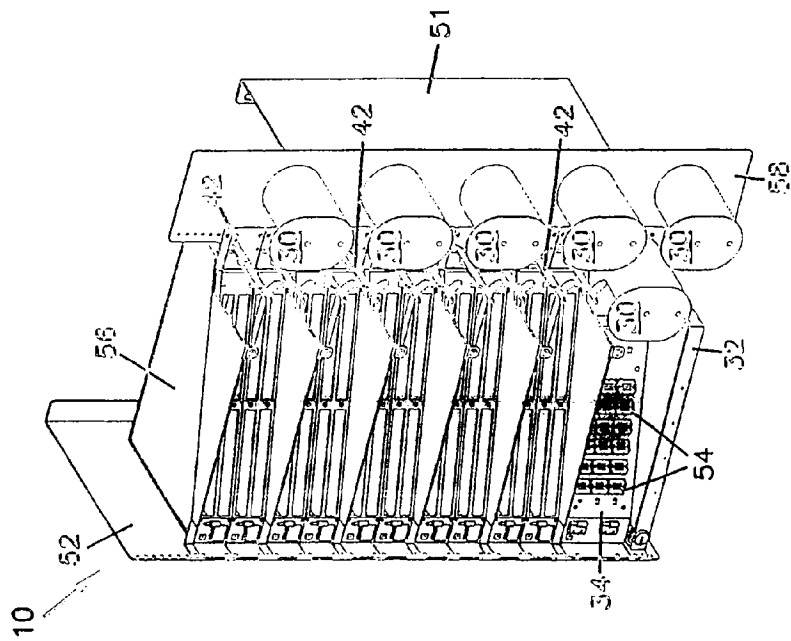

FIG.6

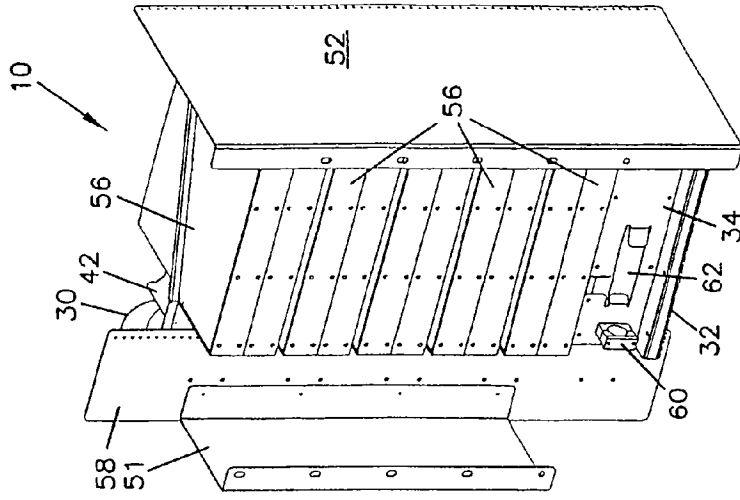

FIG. 7

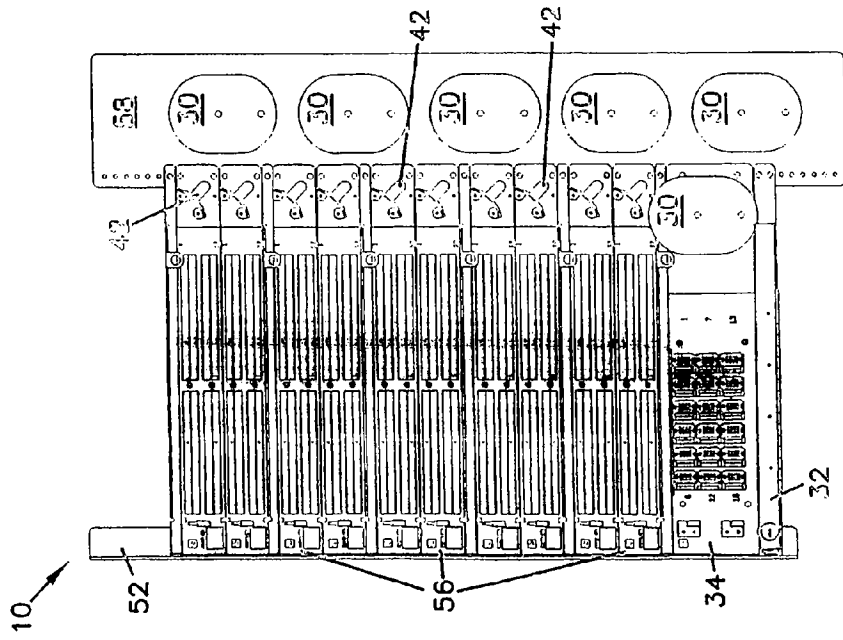

FIG. 8

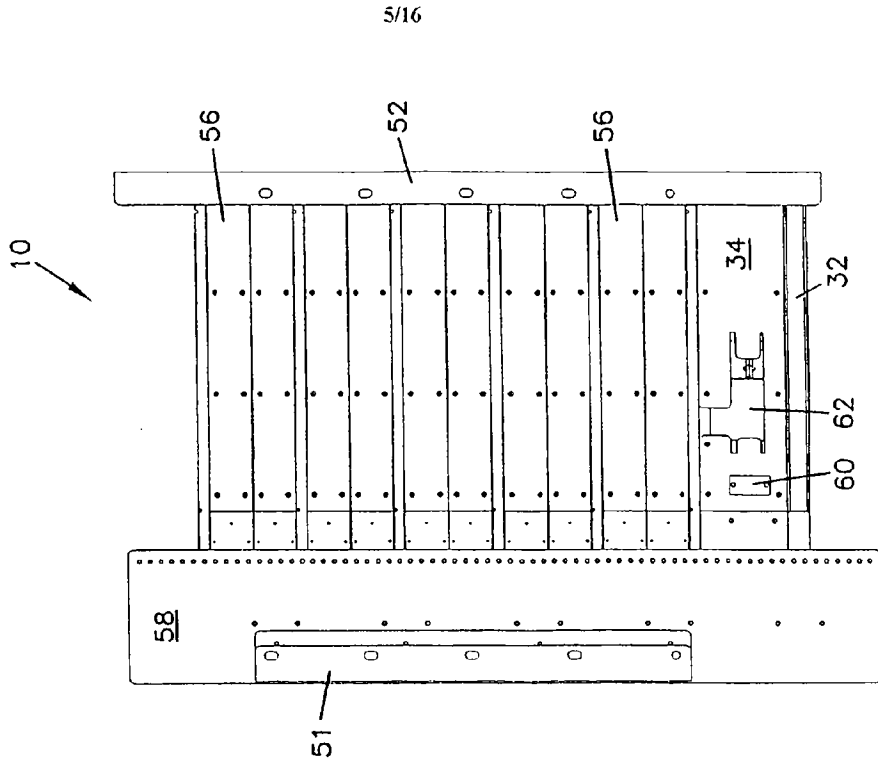

FIG.9

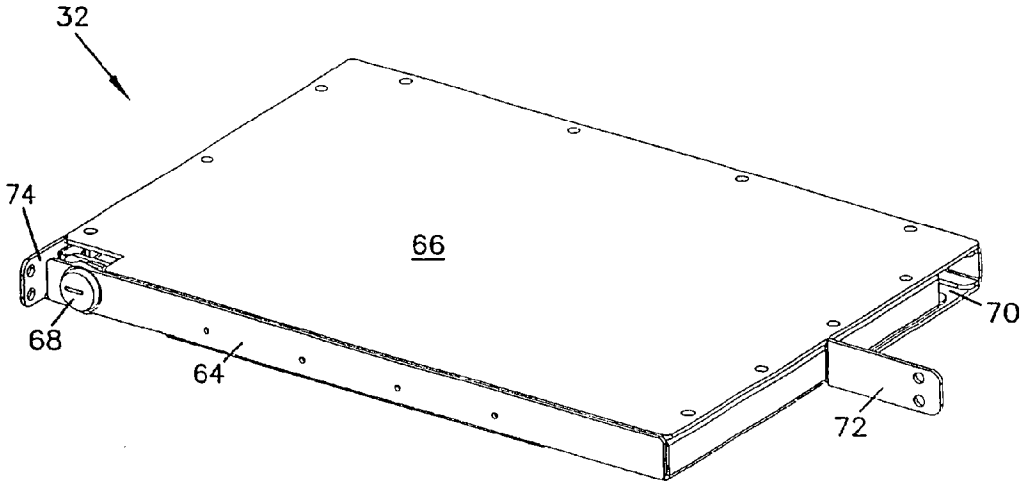

FIG.10

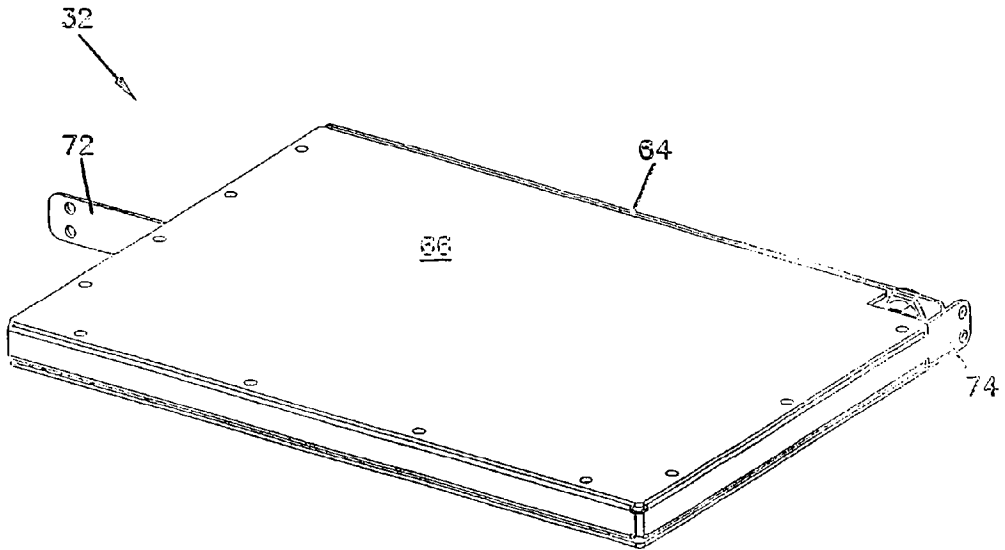

FIG. 11

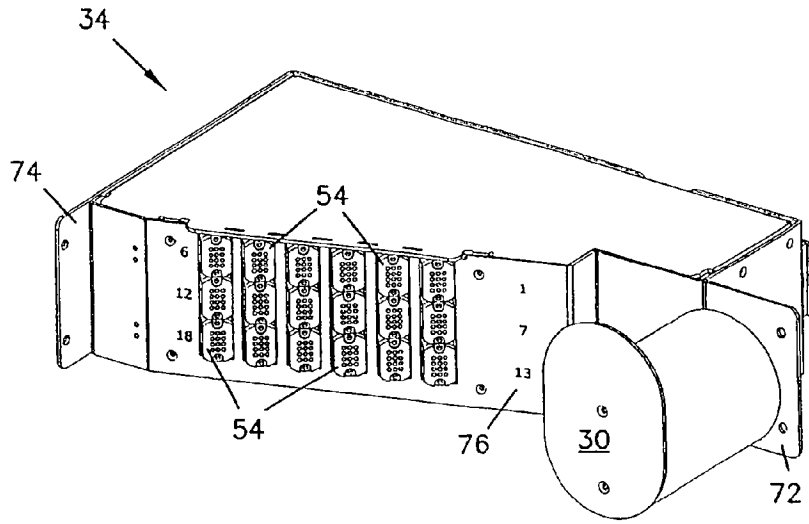

FIG. 12

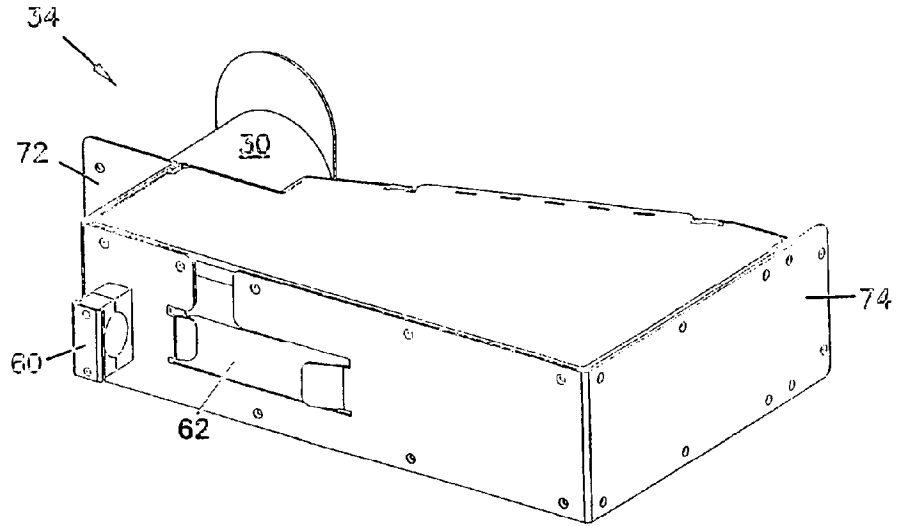

FIG. 13

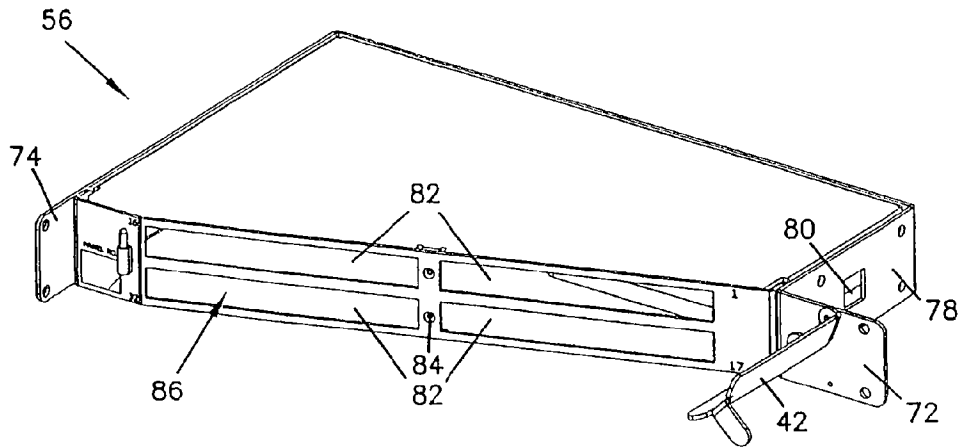
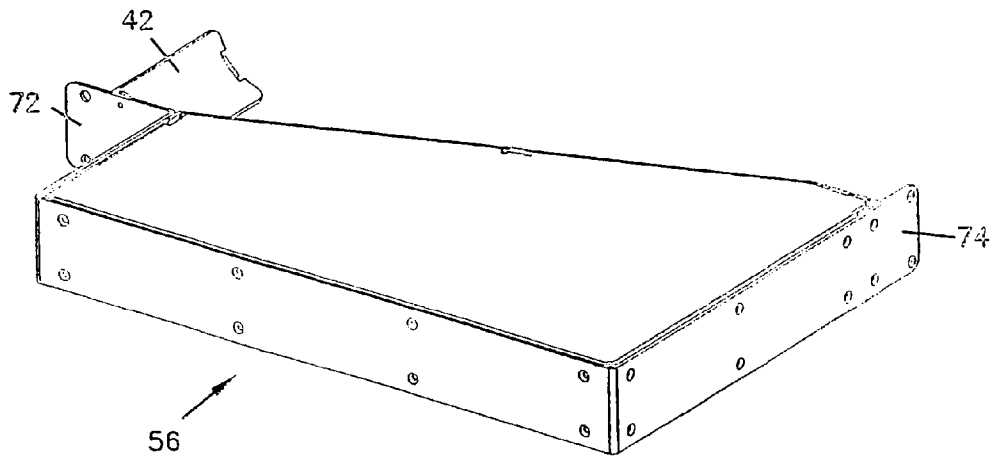
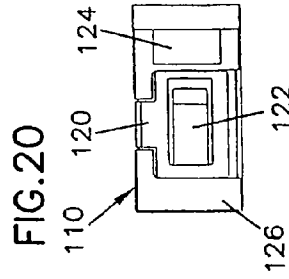
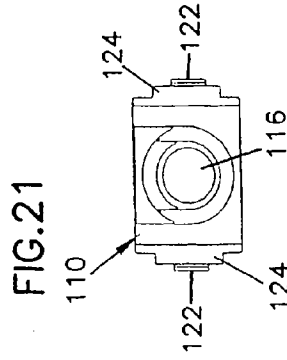
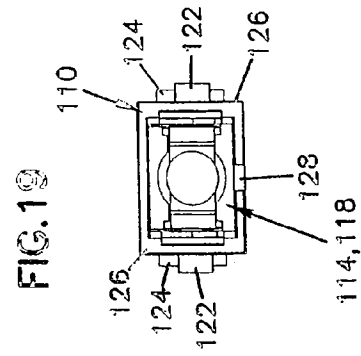
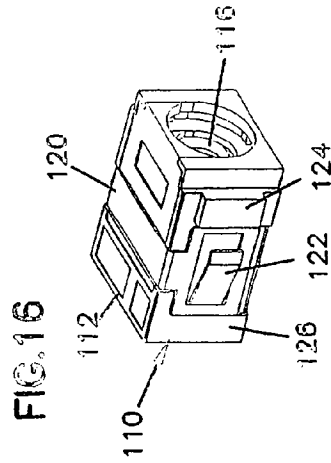
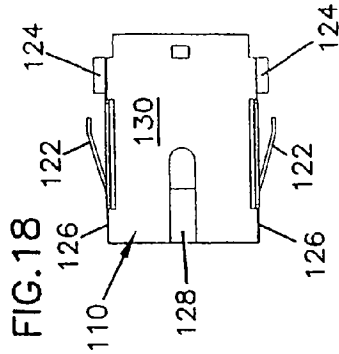
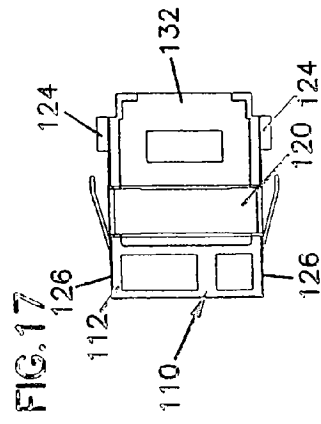
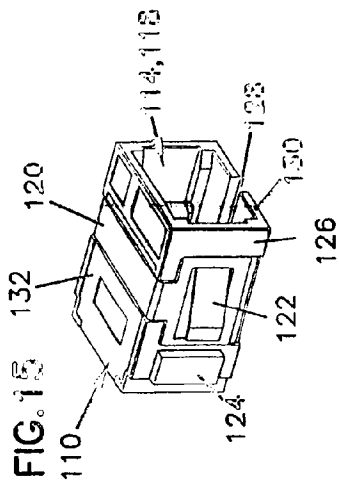

FIG. 14





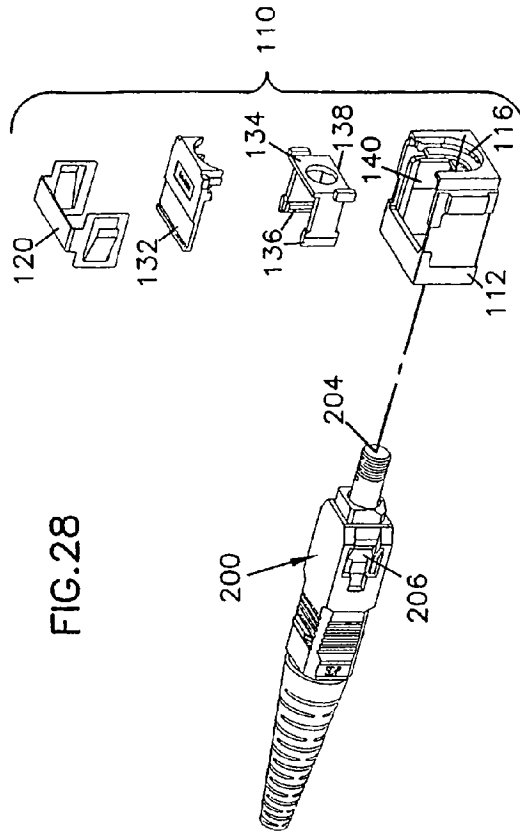
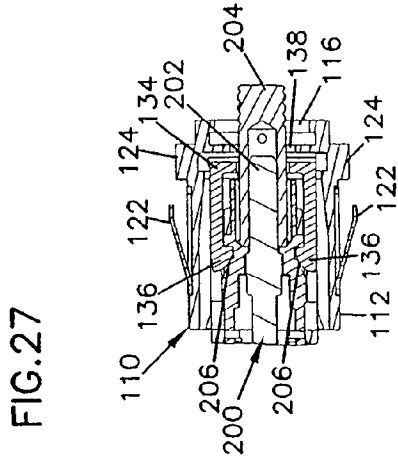
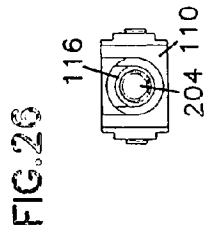
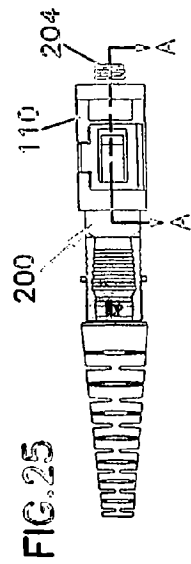
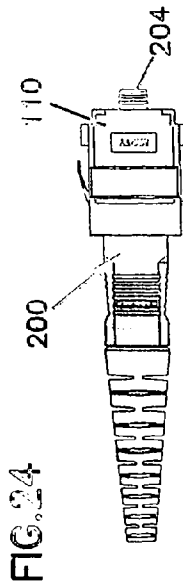
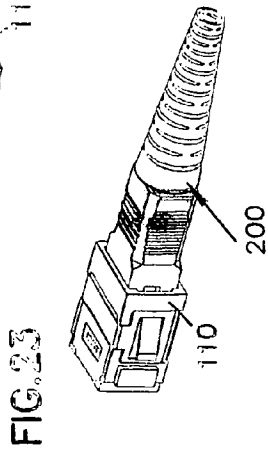
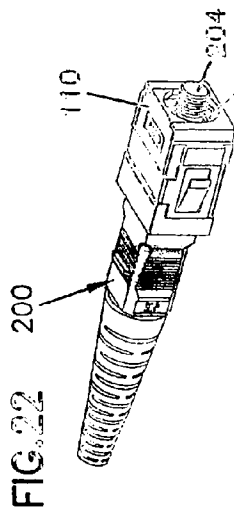

FIG. 29

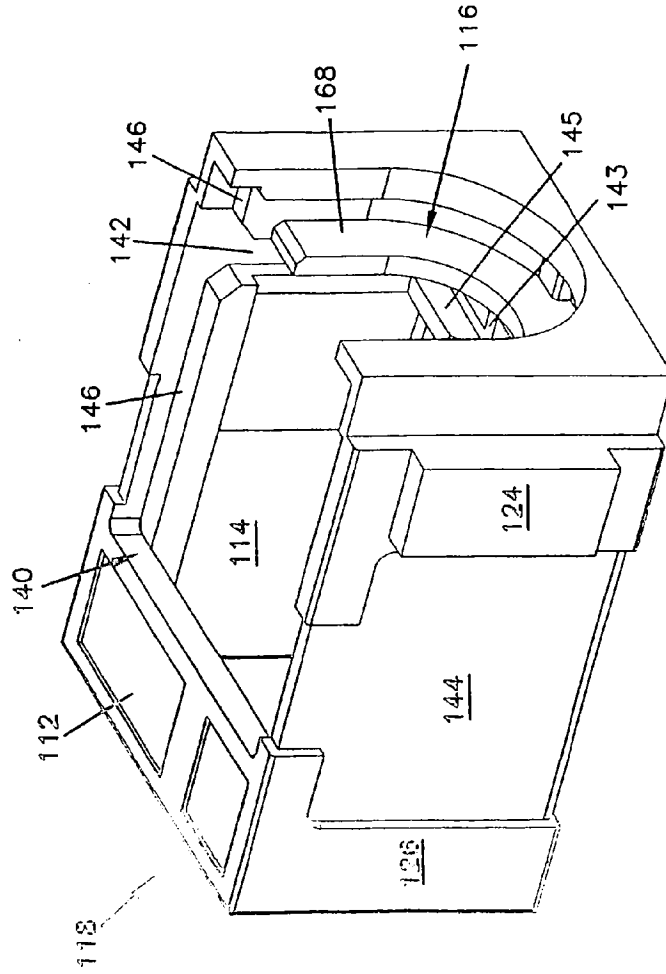

FIG.30

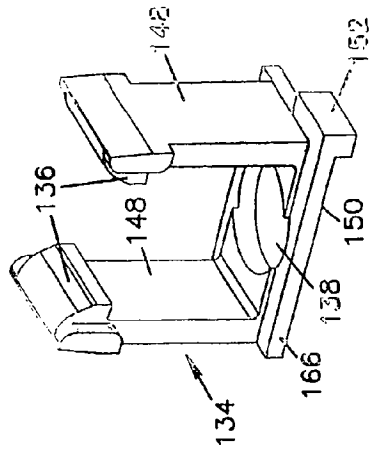

FIG.32

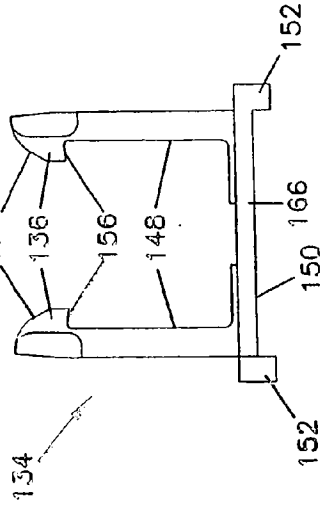

FIG.34

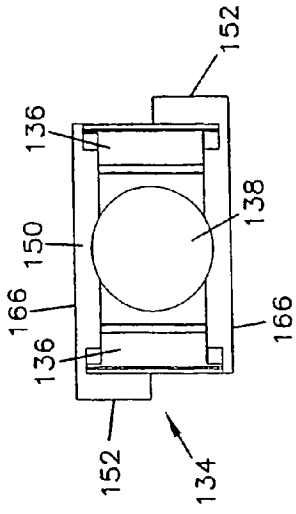

FIG.31

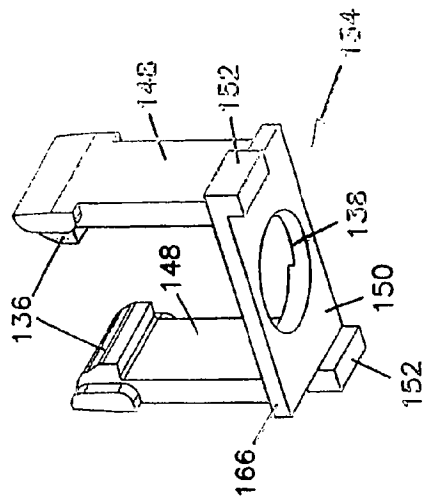

FIG.33

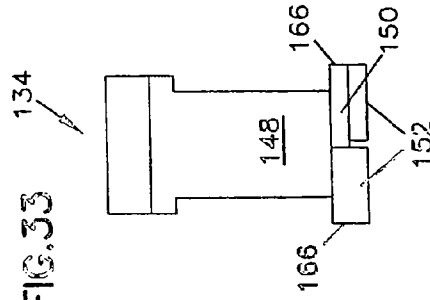

FIG.35

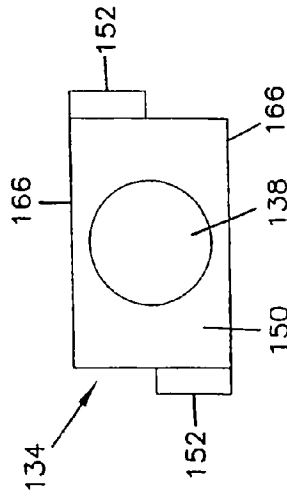

FIG. 36

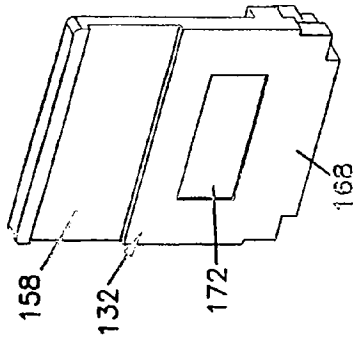

FIG. 37

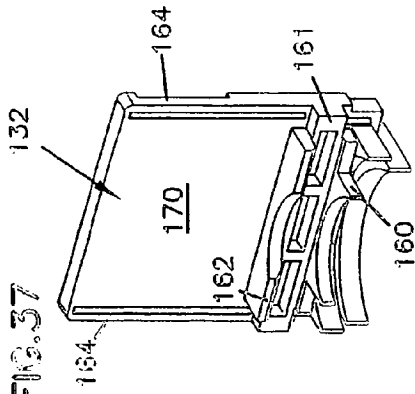

FIG. 38

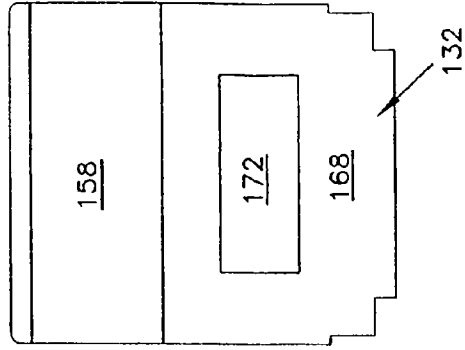

FIG. 39

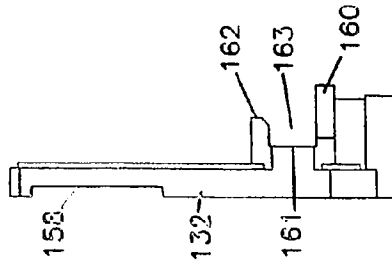

FIG. 40

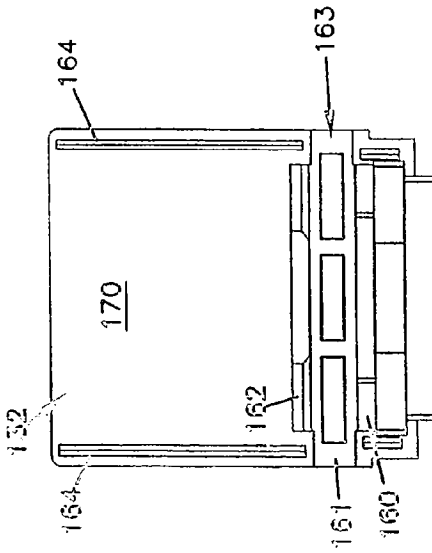

FIG. 41

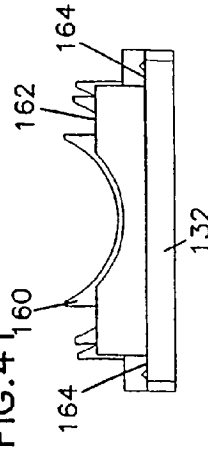
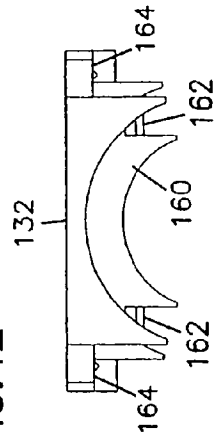
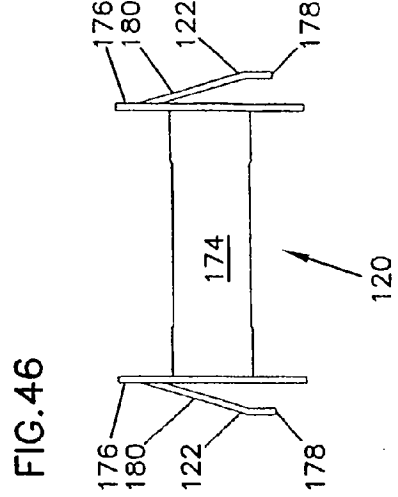
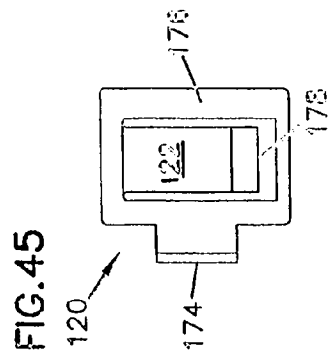
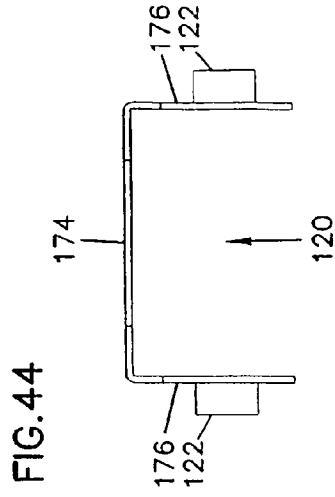
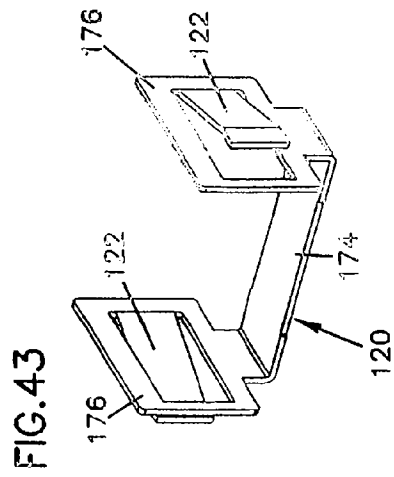

FIG. 42





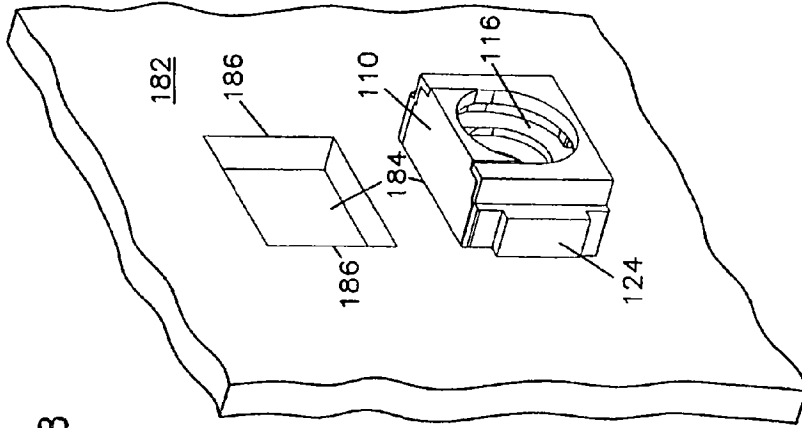

FIG. 48

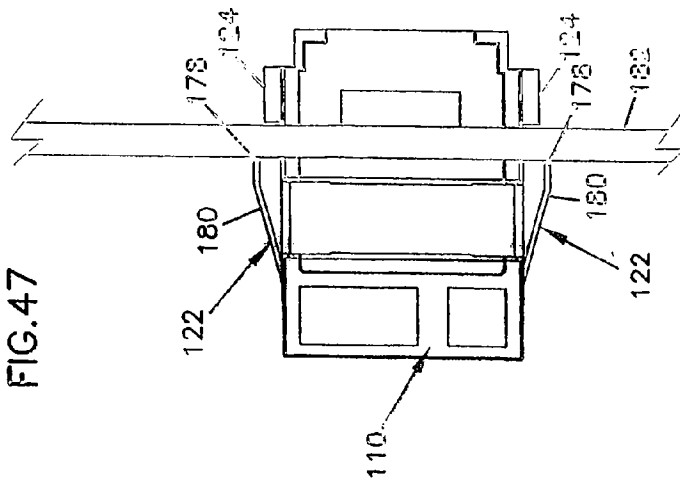

FIG. 47

FIG. 49

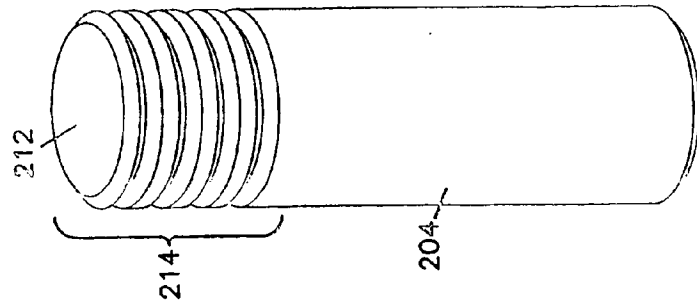

FIG. 50

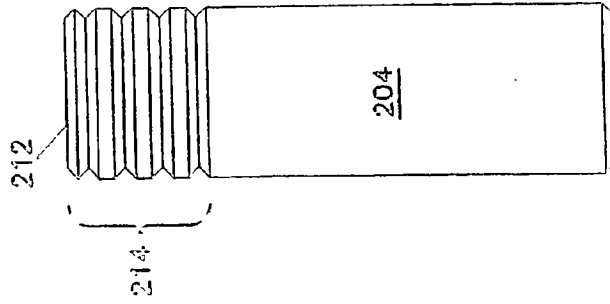

FIG. 51

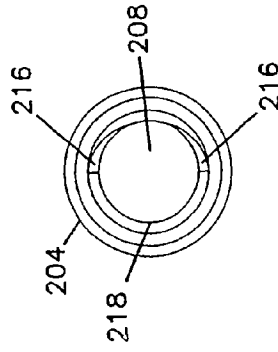

FIG. 52

