



- (51) International Patent Classification:
H04L 29/08 (2006.01)
- (21) International Application Number:
PCT/KR2015/003305
- (22) International Filing Date:
2 April 2015 (02.04.2015)
- (25) Filing Language: English
- (26) Publication Language: English
- (30) Priority Data:
61/982,354 22 April 2014 (22.04.2014) US
- (71) Applicant: **LG ELECTRONICS INC.** [KR/KR]; LG Electronics Inc., 128, Yeoui-daero, Yeongdeungpo-gu, Seoul 150-721 (KR).
- (72) Inventors: **YI, Seungjune**; IP Center, LG Electronics Inc., 19, Yangjae-daero 11gil, Seocho-gu, Seoul 137-893 (KR).
LEE, Sunyoung; IP Center, LG Electronics Inc., 19, Yangjae-daero 11gil, Seocho-gu, Seoul 137-893 (KR).

- (74) Agents: **KIM, Yong In** et al.; KBK & Associates, 7th Floor, 82, Olympic-ro, Songpa-ku, Seoul 138-861 (KR).
- (81) Designated States (*unless otherwise indicated, for every kind of national protection available*): AE, AG, AL, AM, AO, AT, AU, AZ, BA, BB, BG, BH, BN, BR, BW, BY, BZ, CA, CH, CL, CN, CO, CR, CU, CZ, DE, DK, DM, DO, DZ, EC, EE, EG, ES, FI, GB, GD, GE, GH, GM, GT, HN, HR, HU, ID, IL, IN, IR, IS, JP, KE, KG, KN, KP, KR, KZ, LA, LC, LK, LR, LS, LU, LY, MA, MD, ME, MG, MK, MN, MW, MX, MY, MZ, NA, NG, NI, NO, NZ, OM, PA, PE, PG, PH, PL, PT, QA, RO, RS, RU, RW, SA, SC, SD, SE, SG, SK, SL, SM, ST, SV, SY, TH, TJ, TM, TN, TR, TT, TZ, UA, UG, US, UZ, VC, VN, ZA, ZM, ZW.
- (84) Designated States (*unless otherwise indicated, for every kind of regional protection available*): ARIPO (BW, GH, GM, KE, LR, LS, MW, MZ, NA, RW, SD, SL, ST, SZ, TZ, UG, ZM, ZW), Eurasian (AM, AZ, BY, KG, KZ, RU, TJ, TM), European (AL, AT, BE, BG, CH, CY, CZ, DE, DK, EE, ES, FI, FR, GB, GR, HR, HU, IE, IS, IT, LT, LU, LV, MC, MK, MT, NL, NO, PL, PT, RO, RS, SE, SI, SK,

[Continued on next page]

(54) Title: METHOD FOR PROCESSING RECEIVED RLC PDUS FOR D2D COMMUNICATION SYSTEM AND DEVICE THEREFOR

FIG. 17

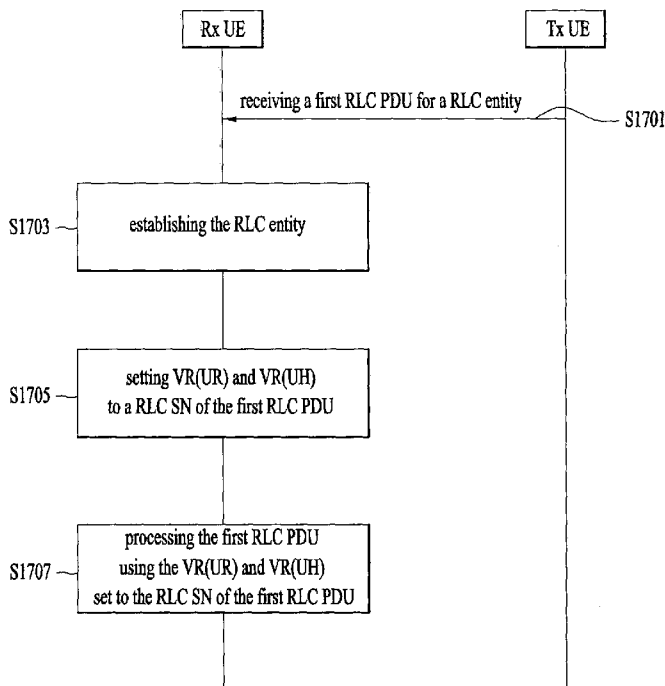

(57) Abstract: The present invention relates to a wireless communication system. More specifically, the present invention relates to a method and a device for processing received RLC PDUs for D2D communication system, the method comprising: receiving a first RLC (Radio Link Control) PDU (Protocol Data Unit) for a RLC entity from a peer UE; establishing the RLC entity to process the first RLC PDU; setting a plurality of state variables for the RLC entity to a RLC sequence number (SN) of the first RLC PDU for the RLC entity; and processing the first RLC PDU using the plurality of state variables for the RLC entity set to the RLC SN of the first RLC PDU for the RLC entity.

WO 2015/163601 A1

SM, TR), OAPI (BF, BJ, CF, CG, CI, CM, GA, GN, GQ, GW, KM, ML, MR, NE, SN, TD, TG). **Published:**

— with international search report (Art. 21(3))

【DESCRIPTION】**【Invention Title】**

METHOD FOR PROCESSING RECEIVED RLC PDUS FOR D2D COMMUNICATION
SYSTEM AND DEVICE THEREFOR

5 **【Technical Field】**

【0001】 The present invention relates to a wireless communication system and, more particularly, to a method for processing received RLC PDUs (Radio Link Control Protocol Data Units) for D2D (Device to Device) communication system and a device therefor.

【Background Art】

10 **【0002】** As an example of a mobile communication system to which the present invention is applicable, a 3rd Generation Partnership Project Long Term Evolution (hereinafter, referred to as LTE) communication system is described in brief.

【0003】 FIG. 1 is a view schematically illustrating a network structure of an E-UMTS as an exemplary radio communication system. An Evolved Universal Mobile Telecommunications System (E-UMTS) is an advanced version of a conventional Universal Mobile Telecommunications System (UMTS) and basic standardization thereof is currently under-
15 way in the 3GPP. E-UMTS may be generally referred to as a Long Term Evolution (LTE) system. For details of the technical specifications of the UMTS and E-UMTS, reference can be made to Release 7 and Release 8 of "3rd Generation Partnership Project; Technical
20 Specification Group Radio Access Network".

【0004】 Referring to FIG. 1, the E-UMTS includes a User Equipment (UE), eNodeBs (eNBs), and an Access Gateway (AG) which is located at an end of the network (E-UTRAN) and connected to an external network. The eNBs may simultaneously transmit multiple data streams for a broadcast service, a multicast service, and/or a unicast service.

[0005] One or more cells may exist per eNB. The cell is set to operate in one of bandwidths such as 1.25, 2.5, 5, 10, 15, and 20 MHz and provides a downlink (DL) or uplink (UL) transmission service to a plurality of UEs in the bandwidth. Different cells may be set to provide different bandwidths. The eNB controls data transmission or reception to and from a plurality of UEs. The eNB transmits DL scheduling information of DL data to a corresponding UE so as to inform the UE of a time/frequency domain in which the DL data is supposed to be transmitted, coding, a data size, and hybrid automatic repeat and request (HARQ)-related information. In addition, the eNB transmits UL scheduling information of UL data to a corresponding UE so as to inform the UE of a time/frequency domain which may be used by the UE, coding, a data size, and HARQ-related information. An interface for transmitting user traffic or control traffic may be used between eNBs. A core network (CN) may include the AG and a network node or the like for user registration of UEs. The AG manages the mobility of a UE on a tracking area (TA) basis. One TA includes a plurality of cells.

[0006] Device to device (D2D) communication refers to the distributed communication technology that directly transfers traffic between adjacent nodes without using infrastructure such as a base station. In a D2D communication environment, each node such as a portable terminal discovers user equipment physically adjacent thereto and transmits traffic after setting communication session. In this way, since D2D communication may solve traffic overload by distributing traffic concentrated into the base station, the D2D communication may have received attention as the element technology of the next generation mobile communication technology after 4G. For this reason, the standard institute such as 3GPP or IEEE has proceeded to establish the D2D communication standard on the basis of LTE-A or Wi-Fi, and Qualcomm has developed their own D2D communication technology.

[0007] It is expected that the D2D communication contributes to increase throughput of a mobile communication system and create new communication services. Also, the D2D communication may support proximity based social network services or network game services. The problem of link of a user equipment located at a shade zone may be solved by using a D2D link as a relay. In this way, it is expected that the D2D technology will provide new services in various fields.

[0008] The D2D communication technologies such as infrared communication, ZigBee, radio frequency identification (RFID) and near field communications (NFC) based on the RFID have been already used. However, since these technologies support communication only of a specific object within a limited distance (about 1m), it is difficult for the technologies to be regarded as the D2D communication technologies strictly.

[0009] Although the D2D communication has been described as above, details of a method for transmitting data from a plurality of D2D user equipments with the same resource have not been suggested.

15 **【Disclosure】**

【Technical Problem】

[0010] An object of the present invention devised to solve the problem lies in a method and device for processing received RLC PDUs for D2D communication system by setting a plurality of state variables for the RLC entity to new state variables. The technical problems solved by the present invention are not limited to the above technical problems and those skilled in the art may understand other technical problems from the following description.

【Technical Solution】

[0011] The object of the present invention can be achieved by providing a method for a User Equipment (UE) operating in a wireless communication system, the method

25

comprising: receiving a first RLC (Radio Link Control) PDU (Protocol Data Unit) for a RLC entity from a peer UE; establishing the RLC entity to process the first RLC PDU; setting a plurality of state variables for the RLC entity to an initial value, wherein the initial value is a RLC sequence number (SN) of the first RLC PDU for the RLC entity; and processing the first RLC PDU using the plurality of state variables for the RLC entity set to the RLC SN of the first RLC PDU for the RLC entity.

[0012] In another aspect of the present invention, provided herein is a UE (User Equipment) for operating in a wireless communication system, the UE comprising: an RF (Radio Frequency) module; and a processor configured to control the RF module, wherein the processor is configured to receive a first RLC (Radio Link Control) PDU (Protocol Data Unit) for a RLC entity from a peer UE, to establish the RLC entity to process the first RLC PDU, to set a plurality of state variables for the RLC entity to an initial value, wherein the initial value is a RLC sequence number (SN) of the first RLC PDU for the RLC entity, and to process the first RLC PDU using the plurality of state variables for the RLC entity set to the RLC SN of the first RLC PDU for the RLC entity.

[0013] Preferably, the RLC entity is a UM (Unacknowledged Mode)-RLC entity.

[0014] Preferably, the RLC PDU is an RLC UMD (Un Unacknowledged Mode Data) PDU.

[0015] Preferably, the plurality of state variables for the RLC entity comprises VR(UR) and VR(UH); wherein the VR(UR) is a received state variable for a UM RLC entity and holds a value of RLC SN of a earliest UMD PDU that is still considered for reordering, and the VR(UH) is highest received state variable for the UM RLC entity and holds a value of RLC SN following SN of a UMD PDU with the highest SN among received UMD PDUs.

[0016] Preferably, the first RLC PDU is an RLC PDU received firstly before any other RLC PDUs are received by the RLC entity from the peer UE.

[0017] It is to be understood that both the foregoing general description and the following detailed description of the present invention are exemplary and explanatory and are intended to provide further explanation of the invention as claimed.

【Advantageous Effects】

[0018] According to the present invention, received RLC PDUs can be efficiently process in D2D communication system by setting a plurality of state variables for the RLC entity to new state variables. It will be appreciated by persons skilled in the art that that the effects achieved by the present invention are not limited to what has been particularly described hereinabove and other advantages of the present invention will be more clearly understood from the following detailed description taken in conjunction with the accompanying drawings.

【Description of Drawings】

[0019] The accompanying drawings, which are included to provide a further understanding of the invention and are incorporated in and constitute a part of this application, illustrate embodiment(s) of the invention and together with the description serve to explain the principle of the invention.

[0020] FIG. 1 is a diagram showing a network structure of an Evolved Universal Mobile Telecommunications System (E-UMTS) as an example of a wireless communication system;

[0021] FIG. 2A is a block diagram illustrating network structure of an evolved universal mobile telecommunication system (E-UMTS), and FIG. 2B is a block diagram depicting architecture of a typical E-UTRAN and a typical EPC;

[0022] FIG. 3 is a diagram showing a control plane and a user plane of a radio interface protocol between a UE and an E-UTRAN based on a 3rd generation partnership project (3GPP) radio access network standard;

[0023] FIG. 4 is a diagram of an example physical channel structure used in an E-
5 UMTS system;

[0024] FIG. 5 is a block diagram of a communication apparatus according to an embodiment of the present invention;

[0025] FIG. 6 is an example of default data path for a normal communication;

[0026] FIGs. 7~8 are examples of data path scenarios for a proximity communication;
10

[0027] FIG. 9 is a conceptual diagram illustrating for a non-roaming reference architecture;

[0028] FIG. 10 is a conceptual diagram illustrating for a Layer 2 Structure for Sidelink;

[0029] FIG. 11a is a conceptual diagram illustrating for User-Plane protocol stack for ProSe Direct Communication, and FIG. 11b is Control-Plane protocol stack for ProSe Direct Communication;
15

[0030] FIG. 12 is a conceptual diagram illustrating for a PC5 interface for ProSe Direct Discovery;

[0031] FIG. 13 is a conceptual diagram illustrating for model of two unacknowledged mode peer entities;
20

[0032] FIGs. 14a to 14f are conceptual diagrams illustrating for UMD PDU;

[0033] FIG. 15 is a conceptual diagram for functional view of a PDCP entity;

[0034] FIGs. 16a and 16b are conceptual diagrams for PDCP Data PDU format for
25 DRBs;

[0035] FIG. 17 is a conceptual diagram for processing received RLC PDU for D2D communication according to embodiments of the present invention; and

[0036] FIG. 18 is a conceptual diagram for processing received PDCP PDU for D2D communication according to embodiments of the present invention.

5 **【Best Mode】**

[0037] Universal mobile telecommunications system (UMTS) is a 3rd Generation (3G) asynchronous mobile communication system operating in wideband code division multiple access (WCDMA) based on European systems, global system for mobile communications (GSM) and general packet radio services (GPRS). The long-term evolution (LTE)
10 of UMTS is under discussion by the 3rd generation partnership project (3GPP) that standardized UMTS.

[0038] The 3GPP LTE is a technology for enabling high-speed packet communications. Many schemes have been proposed for the LTE objective including those that aim to reduce user and provider costs, improve service quality, and expand and improve coverage
15 and system capacity. The 3G LTE requires reduced cost per bit, increased service availability, flexible use of a frequency band, a simple structure, an open interface, and adequate power consumption of a terminal as an upper-level requirement.

[0039] Hereinafter, structures, operations, and other features of the present invention will be readily understood from the embodiments of the present invention, examples of
20 which are illustrated in the accompanying drawings. Embodiments described later are examples in which technical features of the present invention are applied to a 3GPP system.

[0040] Although the embodiments of the present invention are described using a long term evolution (LTE) system and a LTE-advanced (LTE-A) system in the present specification, they are purely exemplary. Therefore, the embodiments of the present inven-
25 tion are applicable to any other communication system corresponding to the above defini-

tion. In addition, although the embodiments of the present invention are described based on a frequency division duplex (FDD) scheme in the present specification, the embodiments of the present invention may be easily modified and applied to a half-duplex FDD (H-FDD) scheme or a time division duplex (TDD) scheme.

5 **[0041]** FIG. 2A is a block diagram illustrating network structure of an evolved universal mobile telecommunication system (E-UMTS). The E-UMTS may be also referred to as an LTE system. The communication network is widely deployed to provide a variety of communication services such as voice (VoIP) through IMS and packet data.

10 **[0042]** As illustrated in FIG. 2A, the E-UMTS network includes an evolved UMTS terrestrial radio access network (E-UTRAN), an Evolved Packet Core (EPC) and one or more user equipment. The E-UTRAN may include one or more evolved NodeB (eNodeB) 20, and a plurality of user equipment (UE) 10 may be located in one cell. One or more E-UTRAN mobility management entity (MME)/system architecture evolution (SAE) gateways 30 may be positioned at the end of the network and connected to an external network.

15 **[0043]** As used herein, “downlink” refers to communication from eNodeB 20 to UE 10, and “uplink” refers to communication from the UE to an eNodeB. UE 10 refers to communication equipment carried by a user and may be also referred to as a mobile station (MS), a user terminal (UT), a subscriber station (SS) or a wireless device.

20 **[0044]** FIG. 2B is a block diagram depicting architecture of a typical E-UTRAN and a typical EPC.

[0045] As illustrated in FIG. 2B, an eNodeB 20 provides end points of a user plane and a control plane to the UE 10. MME/SAE gateway 30 provides an end point of a session and mobility management function for UE 10. The eNodeB and MME/SAE gateway may be connected via an S1 interface.

[0046] The eNodeB 20 is generally a fixed station that communicates with a UE 10, and may also be referred to as a base station (BS) or an access point. One eNodeB 20 may be deployed per cell. An interface for transmitting user traffic or control traffic may be used between eNodeBs 20.

5 [0047] The MME provides various functions including NAS signaling to eNodeBs 20, NAS signaling security, AS Security control, Inter CN node signaling for mobility between 3GPP access networks, Idle mode UE Reachability (including control and execution of paging retransmission), Tracking Area list management (for UE in idle and active mode), PDN GW and Serving GW selection, MME selection for handovers with MME change,
10 SGSN selection for handovers to 2G or 3G 3GPP access networks, Roaming, Authentication, Bearer management functions including dedicated bearer establishment, Support for PWS (which includes ETWS and CMAS) message transmission. The SAE gateway host provides assorted functions including Per-user based packet filtering (by e.g. deep packet inspection), Lawful Interception, UE IP address allocation, Transport level packet marking
15 in the downlink, UL and DL service level charging, gating and rate enforcement, DL rate enforcement based on APN-AMBR. For clarity MME/SAE gateway 30 will be referred to herein simply as a “gateway,” but it is understood that this entity includes both an MME and an SAE gateway.

[0048] A plurality of nodes may be connected between eNodeB 20 and gateway 30
20 via the S1 interface. The eNodeBs 20 may be connected to each other via an X2 interface and neighboring eNodeBs may have a meshed network structure that has the X2 interface.

[0049] As illustrated, eNodeB 20 may perform functions of selection for gateway 30, routing toward the gateway during a Radio Resource Control (RRC) activation, scheduling and transmitting of paging messages, scheduling and transmitting of Broadcast Channel
25 (BCCH) information, dynamic allocation of resources to UEs 10 in both uplink and down-

link, configuration and provisioning of eNodeB measurements, radio bearer control, radio admission control (RAC), and connection mobility control in LTE_ACTIVE state. In the EPC, and as noted above, gateway 30 may perform functions of paging origination, LTE-IDLE state management, ciphering of the user plane, System Architecture Evolution (SAE) bearer control, and ciphering and integrity protection of Non-Access Stratum (NAS) signaling.

[0050] The EPC includes a mobility management entity (MME), a serving-gateway (S-GW), and a packet data network-gateway (PDN-GW). The MME has information about connections and capabilities of UEs, mainly for use in managing the mobility of the UEs. The S-GW is a gateway having the E-UTRAN as an end point, and the PDN-GW is a gateway having a packet data network (PDN) as an end point.

[0051] FIG. 3 is a diagram showing a control plane and a user plane of a radio interface protocol between a UE and an E-UTRAN based on a 3GPP radio access network standard. The control plane refers to a path used for transmitting control messages used for managing a call between the UE and the E-UTRAN. The user plane refers to a path used for transmitting data generated in an application layer, e.g., voice data or Internet packet data.

[0052] A physical (PHY) layer of a first layer provides an information transfer service to a higher layer using a physical channel. The PHY layer is connected to a medium access control (MAC) layer located on the higher layer via a transport channel. Data is transported between the MAC layer and the PHY layer via the transport channel. Data is transported between a physical layer of a transmitting side and a physical layer of a receiving side via physical channels. The physical channels use time and frequency as radio resources. In detail, the physical channel is modulated using an orthogonal frequency divi-

sion multiple access (OFDMA) scheme in downlink and is modulated using a single carrier frequency division multiple access (SC-FDMA) scheme in uplink.

[0053] The MAC layer of a second layer provides a service to a radio link control (RLC) layer of a higher layer via a logical channel. The RLC layer of the second layer supports reliable data transmission. A function of the RLC layer may be implemented by a functional block of the MAC layer. A packet data convergence protocol (PDCP) layer of the second layer performs a header compression function to reduce unnecessary control information for efficient transmission of an Internet protocol (IP) packet such as an IP version 4 (IPv4) packet or an IP version 6 (IPv6) packet in a radio interface having a relatively small bandwidth.

[0054] A radio resource control (RRC) layer located at the bottom of a third layer is defined only in the control plane. The RRC layer controls logical channels, transport channels, and physical channels in relation to configuration, re-configuration, and release of radio bearers (RBs). An RB refers to a service that the second layer provides for data transmission between the UE and the E-UTRAN. To this end, the RRC layer of the UE and the RRC layer of the E-UTRAN exchange RRC messages with each other.

[0055] One cell of the eNB is set to operate in one of bandwidths such as 1.25, 2.5, 5, 10, 15, and 20 MHz and provides a downlink or uplink transmission service to a plurality of UEs in the bandwidth. Different cells may be set to provide different bandwidths.

[0056] Downlink transport channels for transmission of data from the E-UTRAN to the UE include a broadcast channel (BCH) for transmission of system information, a paging channel (PCH) for transmission of paging messages, and a downlink shared channel (SCH) for transmission of user traffic or control messages. Traffic or control messages of a downlink multicast or broadcast service may be transmitted through the downlink SCH and may also be transmitted through a separate downlink multicast channel (MCH).

[0057] Uplink transport channels for transmission of data from the UE to the E-UTRAN include a random access channel (RACH) for transmission of initial control messages and an uplink SCH for transmission of user traffic or control messages. Logical channels that are defined above the transport channels and mapped to the transport channels include a broadcast control channel (BCCH), a paging control channel (PCCH), a common control channel (CCCH), a multicast control channel (MCCH), and a multicast traffic channel (MTCH).

[0058] FIG. 4 is a view showing an example of a physical channel structure used in an E-UMTS system. A physical channel includes several subframes on a time axis and several subcarriers on a frequency axis. Here, one subframe includes a plurality of symbols on the time axis. One subframe includes a plurality of resource blocks and one resource block includes a plurality of symbols and a plurality of subcarriers. In addition, each subframe may use certain subcarriers of certain symbols (e.g., a first symbol) of a subframe for a physical downlink control channel (PDCCH), that is, an L1/L2 control channel. In FIG. 4, an L1/L2 control information transmission area (PDCCH) and a data area (PDSCH) are shown. In one embodiment, a radio frame of 10 ms is used and one radio frame includes 10 subframes. In addition, one subframe includes two consecutive slots. The length of one slot may be 0.5 ms. In addition, one subframe includes a plurality of OFDM symbols and a portion (e.g., a first symbol) of the plurality of OFDM symbols may be used for transmitting the L1/L2 control information. A transmission time interval (TTI) which is a unit time for transmitting data is 1 ms.

[0059] A base station and a UE mostly transmit/receive data via a PDSCH, which is a physical channel, using a DL-SCH which is a transmission channel, except a certain control signal or certain service data. Information indicating to which UE (one or a plurality of

UEs) PDSCH data is transmitted and how the UE receive and decode PDSCH data is transmitted in a state of being included in the PDCCH.

[0060] For example, in one embodiment, a certain PDCCH is CRC-masked with a radio network temporary identity (RNTI) "A" and information about data is transmitted using a radio resource "B" (e.g., a frequency location) and transmission format information "C" (e.g., a transmission block size, modulation, coding information or the like) via a certain subframe. Then, one or more UEs located in a cell monitor the PDCCH using its RNTI information. And, a specific UE with RNTI "A" reads the PDCCH and then receive the PDSCH indicated by B and C in the PDCCH information.

[0061] FIG. 5 is a block diagram of a communication apparatus according to an embodiment of the present invention.

[0062] The apparatus shown in FIG. 5 can be a user equipment (UE) and/or eNB adapted to perform the above mechanism, but it can be any apparatus for performing the same operation.

[0063] As shown in FIG. 5, the apparatus may comprises a DSP/microprocessor (110) and RF module (transceiver; 135). The DSP/microprocessor (110) is electrically connected with the transceiver (135) and controls it. The apparatus may further include power management module (105), battery (155), display (115), keypad (120), SIM card (125), memory device (130), speaker (145) and input device (150), based on its implementation and designer's choice.

[0064] Specifically, FIG. 5 may represent a UE comprising a receiver (135) configured to receive a request message from a network, and a transmitter (135) configured to transmit the transmission or reception timing information to the network. These receiver and the transmitter can constitute the transceiver (135). The UE further comprises a processor (110) connected to the transceiver (135: receiver and transmitter).

[0065] Also, FIG. 5 may represent a network apparatus comprising a transmitter (135) configured to transmit a request message to a UE and a receiver (135) configured to receive the transmission or reception timing information from the UE. These transmitter and receiver may constitute the transceiver (135). The network further comprises a processor (110) connected to the transmitter and the receiver. This processor (110) may be configured to calculate latency based on the transmission or reception timing information.

[0066] Recently, Proximity-based Service (ProSe) has been discussed in 3GPP. The ProSe enables different UEs to be connected (directly) each other (after appropriate procedure(s), such as authentication), through eNB only (but not further through Serving Gateway (SGW) / Packet Data Network Gateway (PDN-GW, PGW)), or through SGW/PGW. Thus, using the ProSe, device to device direct communication can be provided, and it is expected that every devices will be connected with ubiquitous connectivity. Direct communication between devices in a near distance can lessen the load of network. Recently, proximity-based social network services have come to public attention, and new kinds of proximity-based applications can be emerged and may create new business market and revenue. For the first step, public safety and critical communication are required in the market. Group communication is also one of key components in the public safety system. Required functionalities are: Discovery based on proximity, Direct path communication, and Management of group communications.

[0067] Use cases and scenarios are for example: i) Commercial/social use, ii) Network offloading, iii) Public Safety, iv) Integration of current infrastructure services, to assure the consistency of the user experience including reachability and mobility aspects, and v) Public Safety, in case of absence of EUTRAN coverage (subject to regional regulation and operator policy, and limited to specific public-safety designated frequency bands and terminals)

[0068] FIG. 6 is an example of default data path for communication between two UEs. With reference to FIG. 6, even when two UEs (e.g., UE1, UE2) in close proximity communicate with each other, their data path (user plane) goes via the operator network. Thus a typical data path for the communication involves eNB(s) and/or Gateway(s) (GW(s)) (e.g., SGW/PGW).

[0069] FIGs. 7 and 8 are examples of data path scenarios for a proximity communication. If wireless devices (e.g., UE1, UE2) are in proximity of each other, they may be able to use a direct mode data path (FIG. 7) or a locally routed data path (FIG. 8). In the direct mode data path, wireless devices are connected directly each other (after appropriate procedure(s), such as authentication), without eNB and SGW/PGW. In the locally routed data path, wireless devices are connected each other through eNB only.

[0070] FIG. 9 is a conceptual diagram illustrating for a non-roaming reference architecture.

[0071] PC1 to PC 5 represent interfaces. PC1 is a reference point between a ProSe application in a UE and a ProSe App server. It is used to define application level signaling requirements. PC 2 is a reference point between the ProSe App Server and the ProSe Function. It is used to define the interaction between ProSe App Server and ProSe functionality provided by the 3GPP EPS via ProSe Function. One example may be for application data updates for a ProSe database in the ProSe Function. Another example may be data for use by ProSe App Server in interworking between 3GPP functionality and application data, e.g. name translation. PC3 is a reference point between the UE and ProSe Function. It is used to define the interaction between UE and ProSe Function. An example may be to use for configuration for ProSe discovery and communication. PC4 is a reference point between the EPC and ProSe Function. It is used to define the interaction between EPC and ProSe Function. Possible use cases may be when setting up a one-to-one communication path be-

tween UEs or when validating ProSe services (authorization) for session management or mobility management in real time.

[0072] PC5 is a reference point between UE to UE used for control and user plane for discovery and communication, for relay and one-to-one communication (between UEs directly and between UEs over LTE-Uu). Lastly, PC6 is a reference point may be used for functions such as ProSe Discovery between users subscribed to different PLMNs.

[0073] EPC (Evolved Packet Core) includes entities such as MME, S-GW, P-GW, PCRF, HSS etc. The EPC here represents the E-UTRAN Core Network architecture. Interfaces inside the EPC may also be impacted albeit they are not explicitly shown in FIG. 9.

[0074] Application servers, which are users of the ProSe capability for building the application functionality, e.g. in the Public Safety cases they can be specific agencies (PSAP) or in the commercial cases social media. These applications are defined outside the 3GPP architecture but there may be reference points towards 3GPP entities. The Application server can communicate towards an application in the UE.

[0075] Applications in the UE use the ProSe capability for building the application functionality. Example may be for communication between members of Public Safety groups or for social media application that requests to find buddies in proximity. The ProSe Function in the network (as part of EPS) defined by 3GPP has a reference point towards the ProSe App Server, towards the EPC and the UE.

[0076] The functionality may include but not restricted to e.g.:

[0077] - Interworking via a reference point towards the 3rd party Applications

[0078] - Authorization and configuration of the UE for discovery and Direct communication

[0079] - Enable the functionality of the EPC level ProSe discovery

[0080] - ProSe related new subscriber data and /handling of data storage; also handling of ProSe identities;

[0081] - Security related functionality

[0082] - Provide Control towards the EPC for policy related functionality

5 [0083] - Provide functionality for charging (via or outside of EPC, e.g. offline charging)

[0084] Especially, the following identities are used for ProSe Direct Communication:

[0085] - Source Layer-2 ID identifies a sender of a D2D packet at PC5 interface.

10 The Source Layer-2 ID is used for identification of the receiver RLC UM entity;

[0086] - Destination Layer-2 ID identifies a target of the D2D packet at PC5 interface. The Destination Layer-2 ID is used for filtering of packets at the MAC layer. The Destination Layer-2 ID may be a broadcast, groupcast or unicast identifier; and

[0087] - SA L1 ID identifier in Scheduling Assignment (SA) at PC5 interface. SA
15 L1 ID is used for filtering of packets at the physical layer. The SA L1 ID may be a broadcast, groupcast or unicast identifier.

[0088] No Access Stratum signaling is required for group formation and to configure Source Layer-2 ID and Destination Layer-2 ID in the UE. This information is provided by higher layers.

20 [0089] In case of groupcast and unicast, the MAC layer will convert the higher layer ProSe ID (i.e. ProSe Layer-2 Group ID and ProSe UE ID) identifying the target (Group, UE) into two bit strings of which one can be forwarded to the physical layer and used as SA L1 ID whereas the other is used as Destination Layer-2 ID. For broadcast, L2 indicates to L1 that it is a broadcast transmission using a pre-defined SA L1 ID in the same format as
25 for group- and unicast.

[0090] FIG. 10 is a conceptual diagram illustrating for a Layer 2 structure for Sidelink.

[0091] The Sidelink is UE to UE interface for ProSe direct communication and ProSe Direct Discovery. Corresponds to the PC5 interface. The Sidelink comprises ProSe Direct Discovery and ProSe Direct Communication between UEs. The Sidelink uses uplink resources and physical channel structure similar to uplink transmissions. However, some changes, noted below, are made to the physical channels. E-UTRA defines two MAC entities; one in the UE and one in the E-UTRAN. These MAC entities handle the following transport channels additionally, i) sidelink broadcast channel (SL-BCH), ii) sidelink discovery channel (SL-DCH) and iii) sidelink shared channel (SL-SCH).

[0092] - Basic transmission scheme: the Sidelink transmission uses the same basic transmission scheme as the UL transmission scheme. However, sidelink is limited to single cluster transmissions for all the sidelink physical channels. Further, sidelink uses a 1 symbol gap at the end of each sidelink sub-frame.

[0093] - Physical-layer processing: the Sidelink physical layer processing of transport channels differs from UL transmission in the following steps:

[0094] i) Scrambling: for PSDCH and PSCCH, the scrambling is not UE-specific;

[0095] ii) Modulation: 64 QAM is not supported for Sidelink.

[0096] - Physical Sidelink control channel: PSCCH is mapped to the Sidelink control resources. PSCCH indicates resource and other transmission parameters used by a UE for PSSCH.

[0097] - Sidelink reference signals: for PSDCH, PSCCH and PSSCH demodulation, reference signals similar to uplink demodulation reference signals are transmitted in the 4th symbol of the slot in normal CP and in the 3rd symbol of the slot in extended cyclic prefix. The Sidelink demodulation reference signals sequence length equals the size (number of

sub-carriers) of the assigned resource. For PSDCH and PSCCH, reference signals are created based on a fixed base sequence, cyclic shift and orthogonal cover code.

[0098] - Physical channel procedure: for in-coverage operation, the power spectral density of the sidelink transmissions can be influenced by the eNB.

5 [0099] FIG. 11a is a conceptual diagram illustrating for User-Plane protocol stack for ProSe Direct Communication, and FIG. 11b is Control-Plane protocol stack for ProSe Direct Communication.

[00100] FIG. 11a shows the protocol stack for the user plane, where PDCP, RLC and MAC sublayers (terminate at the other UE) perform the functions listed for the user plane
10 (e.g. header compression, HARQ retransmissions). The PC5 interface consists of PDCP, RLC, MAC and PHY as shown in FIG. 11a.

[00101] User plane details of ProSe Direct Communication: i) MAC sub header contains LCIDs (to differentiate multiple logical channels), ii) The MAC header comprises a Source Layer-2 ID and a Destination Layer-2 ID, iii) At MAC Multiplexing/demultiplexing,
15 priority handling and padding are useful for ProSe Direct communication, iv) RLC UM is used for ProSe Direct communication, v) Segmentation and reassembly of RLC SDUs are performed, vi) A receiving UE needs to maintain at least one RLC UM entity per transmitting peer UE, vii) An RLC UM receiver entity does not need to be configured prior to reception of the first RLC UM data unit, and viii) U-Mode is used for header compression in
20 PDCP for ProSe Direct Communication.

[00102] FIG. 11b shows the protocol stack for the control plane, where RRC, RLC, MAC, and PHY sublayers (terminate at the other UE) perform the functions listed for the control plane. A D2D UE does not establish and maintain a logical connection to receiving D2D UEs prior to a D2D communication.

[00103] FIG. 12 is a conceptual diagram illustrating for a PC5 interface for ProSe Direct Discovery.

[00104] ProSe Direct Discovery is defined as the procedure used by the ProSe-enabled UE to discover other ProSe-enabled UE(s) in its proximity using E-UTRA direct radio signals via PC5.

[00105] Radio Protocol Stack (AS) for ProSe Direct Discovery is shown in FIG. 12.

[00106] The AS layer performs the following functions:

[00107] - Interfaces with upper layer (ProSe Protocol): The MAC layer receives the discovery information from the upper layer (ProSe Protocol). The IP layer is not used for transmitting the discovery information.

[00108] - Scheduling: The MAC layer determines the radio resource to be used for announcing the discovery information received from upper layer.

[00109] - Discovery PDU generation: The MAC layer builds the MAC PDU carrying the discovery information and sends the MAC PDU to the physical layer for transmission in the determined radio resource. No MAC header is added.

[00110] There are two types of resource allocation for discovery information announcement.

[00111] - Type 1: A resource allocation procedure where resources for announcing of discovery information are allocated on a non UE specific basis, further characterized by: i) The eNB provides the UE(s) with the resource pool configuration used for announcing of discovery information. The configuration may be signalled in SIB, ii) The UE autonomously selects radio resource(s) from the indicated resource pool and announce discovery information, iii) The UE can announce discovery information on a randomly selected discovery resource during each discovery period.

[00112] - Type 2: A resource allocation procedure where resources for announcing of discovery information are allocated on a per UE specific basis, further characterized by: i) The UE in RRC_CONNECTED may request resource(s) for announcing of discovery information from the eNB via RRC, ii) The eNB assigns resource(s) via RRC, iii) The resources are allocated within the resource pool that is configured in UEs for monitoring.

[00113] For UEs in RRC_IDLE, the eNB may select one of the following options:

[00114] - The eNB may provide a Type 1 resource pool for discovery information announcement in SIB. UEs that are authorized for ProSe Direct Discovery use these resources for announcing discovery information in RRC_IDLE.

10 [00115] - The eNB may indicate in SIB that it supports D2D but does not provide resources for discovery information announcement. UEs need to enter RRC Connected in order to request D2D resources for discovery information announcement.

[00116] For UEs in RRC_CONNECTED,

[00117] - A UE authorized to perform ProSe Direct Discovery announcement indicates to the eNB that it wants to perform D2D discovery announcement.

[00118] - The eNB validates whether the UE is authorized for ProSe Direct Discovery announcement using the UE context received from MME.

[00119] - The eNB may configure the UE to use a Type 1 resource pool or dedicated Type 2 resources for discovery information announcement via dedicated RRC signaling (or no resource).

[00120] - The resources allocated by the eNB are valid until a) the eNB de-configures the resource(s) by RRC signaling or b) the UE enters IDLE. (FFS whether resources may remain valid even in IDLE).

[00121] Receiving UEs in RRC_IDLE and RRC_CONNECTED monitor both Type 1 and Type 2 discovery resource pools as authorized. The eNB provides the resource pool

configuration used for discovery information monitoring in SIB. The SIB may contain discovery resources used for announcing in neighbor cells as well.

[00122] FIG. 13 is a conceptual diagram illustrating for model of two unacknowledged mode peer entities.

5 [00123] In UM (Unacknowledged Mode), in-sequence delivery to higher layers is provided, but no retransmissions of missing PDUs are requested. UM is typically used for services such as VoIP where error-free delivery is of less importance compared to short delivery time. TM (Transparent Mode), although supported, is only used for specific purposes such as random access.

10 [00124] Unacknowledged mode (UM) supports segmentation/reassembly and in-sequence delivery, but not retransmissions. This mode is used when error-free delivery is not required, for example voice-over IP, or when retransmissions cannot be requested, for example broadcast transmissions on MTCH and MCCH using MBSFN.

[00125] When a transmitting UM RLC entity forms UMD PDUs from RLC SDUs,
15 the transmitting UM RLC entity may i) segment and/or concatenate the RLC SDUs so that the UMD PDUs fit within the total size of RLC PDU(s) indicated by lower layer at the particular transmission opportunity notified by lower layer; and ii) include relevant RLC headers in the UMD PDU.

[00126] When a receiving UM RLC entity receives UMD PDUs, the receiving UM
20 RLC entity may i) detect whether or not the UMD PDUs have been received in duplication, and discard duplicated UMD PDUs; ii) reorder the UMD PDUs if they are received out of sequence; iii) detect the loss of UMD PDUs at lower layers and avoid excessive reordering delays; iv) reassemble RLC SDUs from the reordered UMD PDUs (not accounting for RLC PDUs for which losses have been detected) and deliver the RLC SDUs to upper layer in ascending order of the RLC SN; and v) discard received UMD PDUs that cannot be re-
25

assembled into a RLC SDU due to loss at lower layers of an UMD PDU which belonged to the particular RLC SDU.

[00127] At the time of RLC re-establishment, the receiving UM RLC entity may re-assemble RLC SDUs from the UMD PDUs that are received out of sequence and deliver them to upper layer, if possible; ii) discard any remaining UMD PDUs that could not be re-assembled into RLC SDUs; and iii) initialize relevant state variables and stop relevant timers.

[00128] The receiving UM RLC entity may maintain a reordering window according to state variable VR(UH) as follows:

[00129] i) a SN falls within the reordering window if $(VR(UH) - UM_Window_Size) \leq SN < VR(UH)$;

[00130] ii) a SN falls outside of the reordering window otherwise.

[00131] When receiving an UMD PDU from lower layer, the receiving UM RLC entity may either discard the received UMD PDU or place it in the reception buffer.

[00132] If the received UMD PDU was placed in the reception buffer, the receiving UM RLC may update state variables, reassemble and deliver RLC SDUs to upper layer and start/stop t-Reordering as needed.

[00133] When t-Reordering expires, the receiving UM RLC entity may update state variables, reassemble and deliver RLC SDUs to upper layer and start t-Reordering as needed

[00134] When an UMD PDU with SN = x is received from lower layer, the receiving UM RLC entity may discard the received UMD PDU, if $VR(UR) < x < VR(UH)$ and the UMD PDU with SN = x has been received before; or if $(VR(UH) - UM_Window_Size) \leq x < VR(UR)$.

[00135] Else, the receiving UM RLC entity may place the received UMD PDU in the reception buffer.

[00136] When an UMD PDU with $SN = x$ is placed in the reception buffer, the receiving UM RLC entity may update $VR(UH)$ to $x + 1$ and reassemble RLC SDUs from any UMD PDUs with SN that falls outside of the reordering window, remove RLC headers when doing so and deliver the reassembled RLC SDUs to upper layer in ascending order of the RLC SN if not delivered before, if x falls outside of the reordering window.

[00137] If $VR(UR)$ falls outside of the reordering window, the receiving UM RLC entity may set $VR(UR)$ to $(VR(UH) - UM_Window_Size)$.

10 [00138] If the reception buffer contains an UMD PDU with $SN = VR(UR)$, the receiving UM RLC entity may update $VR(UR)$ to the SN of the first UMD PDU with $SN >$ current $VR(UR)$ that has not been received; and reassemble RLC SDUs from any UMD PDUs with $SN <$ updated $VR(UR)$, remove RLC headers when doing so and deliver the reassembled RLC SDUs to upper layer in ascending order of the RLC SN if not delivered before;

15 [00139] If t-Reordering is running and $VR(UX) \leq VR(UR)$; or if t-Reordering is running and $VR(UX)$ falls outside of the reordering window and $VR(UX)$ is not equal to $VR(UH)$, the receiving UM RLC entity may stop and reset t-Reordering.

[00140] If t-Reordering is not running (includes the case when t-Reordering is stopped due to actions above) and $VR(UH) > VR(UR)$, the receiving UM RLC entity may start t-Reordering, and set $VR(UX)$ to $VR(UH)$.

[00141] When t-Reordering expires, the receiving UM RLC entity may update $VR(UR)$ to the SN of the first UMD PDU with $SN \geq VR(UX)$ that has not been received; and reassemble RLC SDUs from any UMD PDUs with $SN <$ updated $VR(UR)$, remove

RLC headers when doing so and deliver the reassembled RLC SDUs to upper layer in ascending order of the RLC SN if not delivered before.

[00142] If $VR(UH) > VR(UR)$, the receiving UM RLC entity may start t-Reordering, and set $VR(UX)$ to $VR(UH)$.

5 **[00143]** Each transmitting UM RLC entity shall maintain the following state variables above mentioned:

[00144] a) $VT(US)$: this state variable holds the value of the SN to be assigned for the next newly generated UMD PDU. It is initially set to 0, and is updated whenever the UM RLC entity delivers an UMD PDU with $SN = VT(US)$.

10 **[00145]** Each receiving UM RLC entity shall maintain the following state variables above mentioned:

[00146] a) $VR(UR)$ – UM receive state variable: this state variable holds the value of the SN of the earliest UMD PDU that is still considered for reordering. It is initially set to 0.

[00147] b) $VR(UX)$ – UM t-Reordering state variable: this state variable holds the
15 value of the SN following the SN of the UMD PDU which triggered t-Reordering.

[00148] c) $VR(UH)$ – UM highest received state variable: this state variable holds the value of the SN following the SN of the UMD PDU with the highest SN among received UMD PDUs, and it serves as the higher edge of the reordering window. It is initially set to 0.

20 **[00149]** FIGs. 14a to 14f are conceptual diagrams illustrating for UMD PDU.

[00150] FIG. 14a is a diagram for a UMD PDU with 5 bit SN, FIG. 14b is a diagram for a UMD PDU with 10 bit SN, FIG. 14c is a diagram for a UMD PDU with 5 bit SN (Odd number of LIs, i.e. $K = 1, 3, 5, \dots$), FIG. 14d is a diagram for a UMD PDU with 5 bit SN (Even number of LIs, i.e. $K = 2, 4, 6, \dots$), FIG. 14e is a UMD PDU with 10 bit SN (Odd

number of LIs, i.e. $K = 1, 3, 5, \dots$), and FIG. 14f is a diagram for a UMD PDU with 10 bit SN (Even number of LIs, i.e. $K = 2, 4, 6, \dots$).

[00151] UMD PDU consists of a Data field and an UMD PDU header. UMD PDU header consists of a fixed part (fields that are present for every UMD PDU) and an extension part (fields that are present for an UMD PDU when necessary). The fixed part of the UMD PDU header itself is byte aligned and consists of a FI, an E and a SN. The extension part of the UMD PDU header itself is byte aligned and consists of E(s) and LI(s).

[00152] An UM RLC entity is configured by RRC to use either a 5 bit SN or a 10 bit SN. When the 5 bit SN is configured, the length of the fixed part of the UMD PDU header is one byte. When the 10 bit SN is configured, the fixed part of the UMD PDU header is identical to the fixed part of the AMD PDU header, except for D/C, RF and P fields all being replaced with R1 fields. The extension part of the UMD PDU header is identical to the extension part of the AMD PDU header (regardless of the configured SN size).

[00153] An UMD PDU header consists of an extension part only when more than one Data field elements are present in the UMD PDU, in which case an E and a LI are present for every Data field element except the last. Furthermore, when an UMD PDU header consists of an odd number of LI(s), four padding bits follow after the last LI.

[00154] In the definition of each field in FIGs 14a to FIG. 14f, the bits in the parameters are represented in which the first and most significant bit is the left most bit and the last and least significant bit is the rightmost bit. Unless mentioned otherwise, integers are encoded in standard binary encoding for unsigned integers.

[00155] - Data field: The Data field elements are mapped to the Data field in the order which they arrive to the RLC entity at the transmitter. The granularity of the Data field size is one byte; and the maximum Data field size is the maximum TB size minus the sum of minimum MAC PDU header size and minimum RLC PDU header size. A UMD PDU

segment is mapped to the Data field. Zero RLC SDU segments and one or more RLC SDUs, one or two RLC SDU segments and zero or more RLC SDUs; the RLC SDU segments are either mapped to the beginning or the end of the Data field, a RLC SDU or RLC SDU segment larger than 2047 octets can only be mapped to the end of the Data field.

5 When there are two RLC SDU segments, they belong to different RLC SDUs.

[00156] - Sequence number (SN) field: the SN field indicates the sequence number of the corresponding UMD or AMD PDU. For an AMD PDU segment, the SN field indicates the sequence number of the original AMD PDU from which the AMD PDU segment was constructed from. The sequence number is incremented by one for every UMD or AMD
 10 PDU. Length is 5 bits or 10 bits (configurable) for UMD PDU.

[00157] - Extension bit (E) field: Length is 1 bit. The E field indicates whether Data field follows or a set of E field and LI field follows. The interpretation of the E field is provided in Table 1 and Table 2.

[00158] [Table 1]

Value	Description
0	Data field follows from the octet following the fixed part of the header
1	A set of E field and LI field follows from the octet following the fixed part of the header

15 [00159] [Table 2]

Value	Description
0	Data field follows from the octet following the LI field following this E field
1	A set of E field and LI field follows from the bit following the LI field following this E field

[00160] - Length Indicator (LI) field: Length is 11 bits. The LI field indicates the length in bytes of the corresponding Data field element present in the RLC data PDU delivered/received by an UM or an AM RLC entity. The first LI present in the RLC data PDU header corresponds to the first Data field element present in the Data field of the RLC data
 20 PDU, the second LI present in the RLC data PDU header corresponds to the second Data field element present in the Data field of the RLC data PDU, and so on. The value 0 is reserved.

[00161] - Framing Info (FI) field: Length is 2 bits. The FI field indicates whether a RLC SDU is segmented at the beginning and/or at the end of the Data field. Specifically, the FI field indicates whether the first byte of the Data field corresponds to the first byte of a RLC SDU, and whether the last byte of the Data field corresponds to the last byte of a RLC SDU. The interpretation of the FI field is provided in Table 3.

[00162] [Table 3]

Value	Description
00	First byte of the Data field corresponds to the first byte of a RLC SDU. Last byte of the Data field corresponds to the last byte of a RLC SDU.
01	First byte of the Data field corresponds to the first byte of a RLC SDU. Last byte of the Data field does not correspond to the last byte of a RLC SDU.
10	First byte of the Data field does not correspond to the first byte of a RLC SDU. Last byte of the Data field corresponds to the last byte of a RLC SDU.
11	First byte of the Data field does not correspond to the first byte of a RLC SDU. Last byte of the Data field does not correspond to the last byte of a RLC SDU.

[00163] FIG. 15 is a conceptual diagram for functional view of a PDCP entity.

[00164] The PDCP entities are located in the PDCP sublayer. Several PDCP entities may be defined for a UE. Each PDCP entity carrying user plane data may be configured to use header compression. Each PDCP entity is carrying the data of one radio bearer. In this version of the specification, only the robust header compression protocol (ROHC), is supported. Every PDCP entity uses at most one ROHC compressor instance and at most one ROHC decompressor instance. A PDCP entity is associated either to the control plane or the user plane depending on which radio bearer it is carrying data for.

[00165] FIG. 15 represents the functional view of the PDCP entity for the PDCP sub-layer, it should not restrict implementation. For RNs, integrity protection and verification are also performed for the u-plane.

[00166] UL Data Transfer Procedures:

[00167] At reception of a PDCP SDU from upper layers, the UE may start a discard timer associated with the PDCP SDU. For a PDCP SDU received from upper layers, the UE may associate a PDCP SN (Sequence Number) corresponding to Next_PDCP_TX_SN

to the PDCP SDU, perform header compression of the PDCP SDU, perform integrity protection and ciphering using COUNT based on TX_HFN and the PDCP SN associated with this PDCP SDU, increment the Next_PDCP_TX_SN by one, and submit the resulting PDCP Data PDU to lower layer.

5 [00168] If the Next_PDCP_TX_SN is greater than Maximum_PDCP_SN, the Next_PDCP_TX_SN is set to '0' and TX_HFN is incremented by one.

[00169] DL Data Transfer Procedures:

[00170] For DRBs mapped on RLC UM, at reception of a PDCP Data PDU from lower layers, if received PDCP SN < Next_PDCP_RX_SN, the UE may increment
10 RX_HFN by one, and decipher the PDCP Data PDU using COUNT based on RX_HFN and the received PDCP SN. And the UE may set Next_PDCP_RX_SN to the received PDCP SN + 1. If Next_PDCP_RX_SN > Maximum_PDCP_SN, the UE may set Next_PDCP_RX_SN to 0, and increment RX_HFN by one.

[00171] The UE may perform header decompression (if configured) of the deciphered PDCP Data PDU, and deliver the resulting PDCP SDU to upper layer.
15

[00172] FIGs. 16a and 16b are conceptual diagrams for PDCP Data PDU format for DRBs.

[00173] FIG. 16a shows the format of the PDCP Data PDU when a 12 bit SN length is used. This format is applicable for PDCP Data PDUs carrying data from DRBs mapped
20 on RLC AM or RLC UM.

[00174] And the FIG. 16b shows the format of the PDCP Data PDU when a 7 bit SN length is used. This format is applicable for PDCP Data PDUs carrying data from DRBs mapped on RLC UM.

[00175] The receiving side of each PDCP entity may maintain the following state
25 variables:

[00176] a) Next_PDCP_RX_SN: The variable Next_PDCP_RX_SN indicates the next expected PDCP SN by the receiver for a given PDCP entity. At establishment of the PDCP entity, the UE shall set Next_PDCP_RX_SN to 0.

[00177] b) RX_HFN: the variable RX_HFN indicates the HFN value for the generation of the COUNT value used for the received PDCP PDUs for a given PDCP entity. At establishment of the PDCP entity, the UE shall set RX_HFN to 0.

[00178] c) Last_Submitted_PDCP_RX_SN: for PDCP entities for DRBs mapped on RLC AM the variable Last_Submitted_PDCP_RX_SN indicates the SN of the last PDCP SDU delivered to the upper layers. At establishment of the PDCP entity, the UE shall set Last_Submitted_PDCP_RX_SN to Maximum_PDCP_SN.

[00179] In D2D communication, the UM RLC entity and the PDCP entity are established in the receiver side when the receiver receives the first RLC UMD PDU from the transmitter. At establishment, according to the prior art, the related state variables in the RLC entity (i.e. VR(UR) and VR(UH)) and PDCP entity (i.e. Next_PDCP_RX_SN and RX_HFN) are initialized to zero. However, this behavior causes following problems in RLC and PDCP, respectively.

[00180] In case of RLC entity, one of the current functions of the RLC UM entity is to perform re-ordering and duplicate detection. The RLC entity may discard received UMD PDUs if any of the conditions are met, if $VR(UR) < x < VR(UH)$ and the UMD PDU with SN = x has been received before; or if $(VR(UH) - UM_Window_Size) \leq x < VR(UR)$.

[00181] Given the fact that a receiving UE can join/re-join the data reception from a transmitting source at any point in time, there is a possibility that the SN of the received packet will fall within the discard window and is incorrectly discarded. The probability of discarding packets will depend on the window size. For example, when a UE first sets up the receiving RLC entity, VR(UR) and VR(UH) are initially set to zero. The window size is

set to 512 for a 10 bit SN. According to the formula above if the SN of the first received packet is between 512 and 1023 then the UE would discard the packet. The UE will continue discarding packets until a packet between 0 and 511 is received.

[00182] In case of PDCP entity, one of the current functions of the PDCP entity is to perform deciphering of the received PDCP SDU. The deciphering is performed based on the HFN and received PDCP SN. The HFN is increased by one when the PDCP SN wraps around .

[00183] The receiving UE establishes the PDCP entity when the first RLC UMD PDU is received from a transmitting UE, in which case the RX_HFN and Next_PDCP_RX_SN are initialized to zero. However, given the fact that a receiving UE can join/re-join the data reception from a transmitting source at any point in time, there is a possibility that the HFN is already increased to a certain value depending on the number of PDCP SN wrap around. If the HFN is desynchronized between the transmitter and the receiver, the receiver cannot decipher the received PDCP PDU correctly, and the communication will fail.

[00184] FIG. 17 is a conceptual diagram for processing RLC PDU for D2D communication according to embodiments of the present invention.

[00185] In order to synchronize the RLC and PDCP state variables between the transmitter and the receiver at the RLC and PDCP entity establishment in the receiver, the following methods are invented.

[00186] In RLC entity, when a receiver receives a first RLC PDU for a UM RLC entity from a transmitter, it establishes the UM RLC entity and sets the UM RLC state variables, VR(UH) and VR(UR), to the RLC sequence number (SN) of the first received RLC PDU for the UM RLC entity.

[00187] When a receiving UE (rx UE) receives a first RLC PDU for a RLC entity from a transmitting UE (tx UE) (S1701), the receiving UE establishes the RLC entity to process the first RLC PDU (S1703).

[00188] Preferably, the RLC entity established belongs to a sidelink radio bearer
5 above mentioned.

[00189] Preferably, the first RLC PDU is an RLC PDU received firstly before any other RLC PDUs are received by the RLC entity from the transmitting UE.

[00190] After the step of S1703, the receiving UE sets state variables (e.g, VR(UR) and VR(UH)) for the RLC entity to a RLC sequence number (SN) of the first RLC PDU for
10 the RLC entity (S1705).

[00191] Preferably, the VR(UR) is a received state variable for a UM RLC entity and holds a value of RLC SN of a earliest UMD PDU that is still considered for reordering. For RLC entity configured for STCH, it is initially set to the SN of the first received UMD PDU.

[00192] Preferably, the VR(UH) is highest received state variable for the UM RLC
15 entity and holds a value of RLC SN following SN of a UMD PDU with the highest SN among received UMD PDUs. For RLC entity configured for STCH, it is initially set to the SN of the first received UMD PDU.

[00193] In other words, the UM RLC state variables, VR(UH) and VR(UR), are initialized to the RLC SN of the first received UMD PDU for the UM RLC entity.

[00194] After initializing the VR(UR) and VR(UH) to the RLC SN of the first received UMD PDU, the receiver processes the UMD PDU using the initialized VR(UR) and VR(UH) (S1507). Since the first received SN is equal to VR(UR) and VR(UH), the first received UMD PDU is considered to be within the receiving window, and thus it is not discarded according to the following procedure.

[00195] When an UMD PDU with SN = x is received from lower layer, the receiving RLC entity may discard the received UMD PDU, if $VR(UR) < x < VR(UH)$ and the UMD PDU with SN = x has been received before; or if $(VR(UH) - UM_Window_Size) \leq x < VR(UR)$. Otherwise, the receiving RLC entity may place the received UMD PDU in the reception buffer.

[00196] Preferably, the RLC entity may be a UM (Unacknowledged Mode)-RLC entity.

[00197] Preferably, the RLC PDU is an RLC UMD (Un Unacknowledged Mode Data) PDU.

10 [00198] FIG. 18 is a conceptual diagram for processing PDCP PDU for D2D communication according to embodiments of the present invention.

[00199] In order to synchronize the RLC and PDCP state variables between the transmitter and the receiver at the RLC and PDCP entity establishment in the receiver, the following methods are invented.

15 [00200] In a PDCP entity, a transmitting UE (tx UE) establishes a PDCP entity for transmitting a PDCP PDU to a receiving UE (rx UE) (S1801). When the transmitting UE receives a PDCP SDU from an upper layer (S1803), the transmitting UE sets a COUNT for the PDCP SDU using a fixed value and a PDCP Sequence Number associated with the PDCP SDU (S1805).

20 [00201] Preferably, the PDCP entity established belongs to a sidelink radio bearer above mentioned.

[00202] Preferably, bits of the COUNT consists of bits of the fixed value and bits of the PDCP SN, wherein the bits of the fixed value is a MSB (most significant bit) part of the COUNT, and the bits of the PDCP SN is a LSB (least significant bit) part of the COUNT.

[00203] The bits in the parameters are represented in which the first and most significant bit is the left most bit and the last and least significant bit is the rightmost bit. Unless mentioned otherwise, integers are encoded in standard binary encoding for unsigned integers.

5 [00204] Preferably, wherein the COUNT is 32bits, the fixed value is 16 bits and, the PDCP SN is 16bits. Thus, if the fixed value may be 'zero', 16 bit string occupied as 'zero' is the MSB part of the COUNT. That means the PDCP SN is pre-pended with 0s to make it 32 bits long and it is input into zeroth-order of COUNT to 31st of COUNT.

[00205] Preferably, the fixed value may be PTK ID. Actually, the PTK ID is not a
10 fixed value, but the PTK ID can be used for the MSB part of the COUNT. Thus, zeroth-order of COUNT to 15th of COUNT are set to PTK ID, and PDCP SN is input into 16th of COUNT to 31st of COUNT.

[00206] The PTK (ProSe Traffic Key) identity may be set to a unique value in the
15 sending UE that has not been previously used together with the same PGK and PGK identity in the UE. A 16-bit counter in association with the Group Identity, PGK identity and the Group Member Identity may be used as the PTK identity. Every time a new PTK needs to be derived, the PTK Identity counter is incremented.

[00207] After the step of S1805, the transmitting UE ciphers the PDCP SDU using
20 the COUNT (S1807). The transmitting UE generates a PDCP PDU including the PDCP SDU and a header including the PDCP SN of the PDCP SDU (S1809).

[00208] And the transmitting UE transmits the PDCP PDU to the receiving UE (S1811).

[00209] When the receiving UE receives the PDCP PDU for a PDCP entity from the
25 transmitting UE (S1811), the receiving UE sets a COUNT for the PDCP PDU using a fixed value and a PDCP Sequence Number (SN) associated with PDCP PDU (S1813).

[00210] The receiving UE does not know the fixed value (e.g, RX_HFN), and the deciphering would not succeed unless the receiver sets the fixed value to the correct value. For the receiving UE to synchronize the fixed value to the transmitting UE, it is therefore invented that the fixed value is used for the D2D communication.

5 [00211] Preferably, bits of the COUNT consists of bits of the fixed value and bits of the PDCP SN, wherein the bits of the fixed value is a MSB (most significant bit) part of the COUNT, and the bits of the PDCP SN is a LSB (least significant bit) part of the COUNT.

[00212] The bits in the parameters are represented in which the first and most significant bit is the left most bit and the last and least significant bit is the rightmost bit. Unless
10 mentioned otherwise, integers are encoded in standard binary encoding for unsigned integers.

[00213] Preferably, wherein the COUNT is 32bits, the fixed value is 16 bits and, the PDCP SN is 16bits. Thus, if the fixed value may be 'zero', 16 bit string occupied as 'zero' is the MSB part of the COUNT. That means the PDCP SN is pre-pended with 0s to make it
15 32 bits long and it is input into zeroth-order of COUNT to 31st of COUNT.

[00214] Preferably, the fixed value may be PTK ID. Actually, the PTK ID is not a fixed value, but the PTK ID can be used for the MSB part of the COUNT. Thus, zeroth-order of COUNT to 15th of COUNT are set to PTK ID, and PDCP SN is input into 16th of COUNT to 31st of COUNT.

20 [00215] After the step of S1815, the receiving UE deciphers the PDCP PDU using the COUNT (S1815).

[00216] When the receiving UE receives the PDCP PDU for a PDCP entity from the transmitting UE (S1811), the receiving UE sets the PDCP state variable, Next_PDCP_RX_SN, to the PDCP SN of the received PDCP PDU for the PDCP entity
25 (S1807).

[00217] Preferably, the PDCP PDU received at the step of S1811 is a PDCP PDU received firstly before any other PDCP PDUs are received by the PDCP entity from the transmitting UE. Thus, the receiving UE sets Next_PDCP_RX_SN to the PDCP SN of the first PDCP PDU for the PDCP entity (S1807).

5 [00218] Preferably, Next_PDCP_RX_SN indicates a next expected PDCP SN by a receiver for a given PDCP entity.

[00219] In other words, the PDCP state variable, Next_PDCP_RX_SN, is initialized to the PDCP SN of the received PDCP PDU for the PDCP entity.

[00220] Preferably, the fixed can be signaled to the receiving UE by the eNB when
10 the eNB configures D2D configuration to the receiving UE, or can be fixed in the specification.

[00221] The transmitting UE and the receiving UE set a HFN value to the fixed value at establishment, and use the fixed HFN value for ciphering/deciphering of all the PDCP PDUs.

15 [00222] For the transmitting UE avoids HFN increment due to PDCP SN wrap around, it is also invented that the transmitting UE releases the used PDCP entity (S1821) and establishes a new PDCP entity (S1823) if a PDCP SN of a received PDCP SDU reaches the maximum value of the PDCP SN.

[00223] After initializing the Next_PDCP_RX_SN to the PDCP SN of the first re-
20 ceived PDCP PDU and RX_HFN to the fixed value (S1813), the receiving UE processes the received PDCP PDU using the initialized Next_PDCP_RX_SN and RX_HFN (S1815).

[00224] It will be apparent to those skilled in the art that various modifications and variations can be made in the present invention without departing from the spirit or scope of the invention. Thus, it is intended that the present invention cover the modifications and

variations of this invention provided they come within the scope of the appended claims and their equivalents.

[00225] The embodiments of the present invention described hereinbelow are combinations of elements and features of the present invention. The elements or features may be considered selective unless otherwise mentioned. Each element or feature may be practiced without being combined with other elements or features. Further, an embodiment of the present invention may be constructed by combining parts of the elements and/or features. Operation orders described in embodiments of the present invention may be rearranged. Some constructions of any one embodiment may be included in another embodiment and may be replaced with corresponding constructions of another embodiment. It is obvious to those skilled in the art that claims that are not explicitly cited in each other in the appended claims may be presented in combination as an embodiment of the present invention or included as a new claim by subsequent amendment after the application is filed.

[00226] In the embodiments of the present invention, a specific operation described as performed by the BS may be performed by an upper node of the BS. Namely, it is apparent that, in a network comprised of a plurality of network nodes including a BS, various operations performed for communication with an MS may be performed by the BS, or network nodes other than the BS. The term 'eNB' may be replaced with the term 'fixed station', 'Node B', 'Base Station (BS)', 'access point', etc.

[00227] The above-described embodiments may be implemented by various means, for example, by hardware, firmware, software, or a combination thereof.

[00228] In a hardware configuration, the method according to the embodiments of the present invention may be implemented by one or more Application Specific Integrated Circuits (ASICs), Digital Signal Processors (DSPs), Digital Signal Processing Devices

(DSPDs), Programmable Logic Devices (PLDs), Field Programmable Gate Arrays (FPGAs), processors, controllers, microcontrollers, or microprocessors.

[00229] In a firmware or software configuration, the method according to the embodiments of the present invention may be implemented in the form of modules, procedures, functions, etc. performing the above-described functions or operations. Software code may be stored in a memory unit and executed by a processor. The memory unit may be located at the interior or exterior of the processor and may transmit and receive data to and from the processor via various known means.

[00230] Those skilled in the art will appreciate that the present invention may be carried out in other specific ways than those set forth herein without departing from the spirit and essential characteristics of the present invention. The above embodiments are therefore to be construed in all aspects as illustrative and not restrictive. The scope of the invention should be determined by the appended claims and their legal equivalents, not by the above description, and all changes coming within the meaning and equivalency range of the appended claims are intended to be embraced therein.

【Industrial Applicability】

[00231] While the above-described method has been described centering on an example applied to the 3GPP LTE system, the present invention is applicable to a variety of wireless communication systems in addition to the 3GPP LTE system.

20

【CLAIMS】

1. A method for a User Equipment (UE) operating in a wireless communication system, the method comprising:

receiving a first RLC (Radio Link Control) PDU (Protocol Data Unit) for a RLC entity from a peer UE;

establishing the RLC entity to process the first RLC PDU;

setting a plurality of state variables for the RLC entity to an initial value, wherein the initial value is a RLC sequence number (SN) of the first RLC PDU for the RLC entity; and

processing the first RLC PDU using the plurality of state variables for the RLC entity set to the RLC SN of the first RLC PDU for the RLC entity.

2. The method according to claim 1, wherein the RLC entity is a UM (Unacknowledged Mode)-RLC entity.

3. The method according to claim 1, wherein the RLC PDU is an RLC UMD (Unacknowledged Mode Data) PDU.

4. The method according to claim 1, wherein the plurality of state variables for the RLC entity comprises VR(UR) and VR(UH),

wherein the VR(UR) is a received state variable for a UM RLC entity and holds a value of RLC SN of a earliest UMD PDU that is still considered for reordering, and

wherein the VR(UH) is highest received state variable for the UM RLC entity and holds a value of RLC SN following SN of a UMD PDU with the highest SN among received UMD PDUs.

5. The method according to claim 1, wherein the first RLC PDU is an RLC PDU received firstly before any other RLC PDUs are received by the RLC entity from the peer UE.

5 6. A User Equipment (UE) operating in a wireless communication system, the UE comprising:

a RF (Radio Frequency) module; and

a processor configured to control the RF module,

wherein the processor is configured to receive a first RLC (Radio Link Control) PDU (Protocol Data Unit) for a RLC entity from a peer UE, to establish the RLC entity to process the first RLC PDU, to set a plurality of state variables for the RLC entity to an initial value, wherein the initial value is a RLC sequence number (SN) of the first RLC PDU for the RLC entity, and to process the first RLC PDU using the plurality of state variables for the RLC entity set to the RLC SN of the first RLC PDU for the RLC entity.

15

7. The UE according to claim 6, wherein the RLC entity is a UM (Unacknowledged Mode)-RLC entity.

8. The UE according to claim 6, wherein the RLC PDU is an RLC UMD (Unacknowledged Mode Data) PDU.

20

9. The UE according to claim 6, wherein the plurality of state variables for the RLC entity comprises VR(UR) and VR(UH),

wherein the VR(UR) is a received state variable for a UM RLC entity and holds a value of RLC SN of a earliest UMD PDU that is still considered for reordering, and

25

wherein the VR(UH) is highest received state variable for the UM RLC entity and holds a value of RLC SN following SN of a UMD PDU with the highest SN among received UMD PDUs.

- 5 10. The UE according to claim 6, wherein the processor is further configured to receive firstly the first RLC PDU, before any other RLC PDUs are received by the RLC entity from the peer UE.

FIG. 1

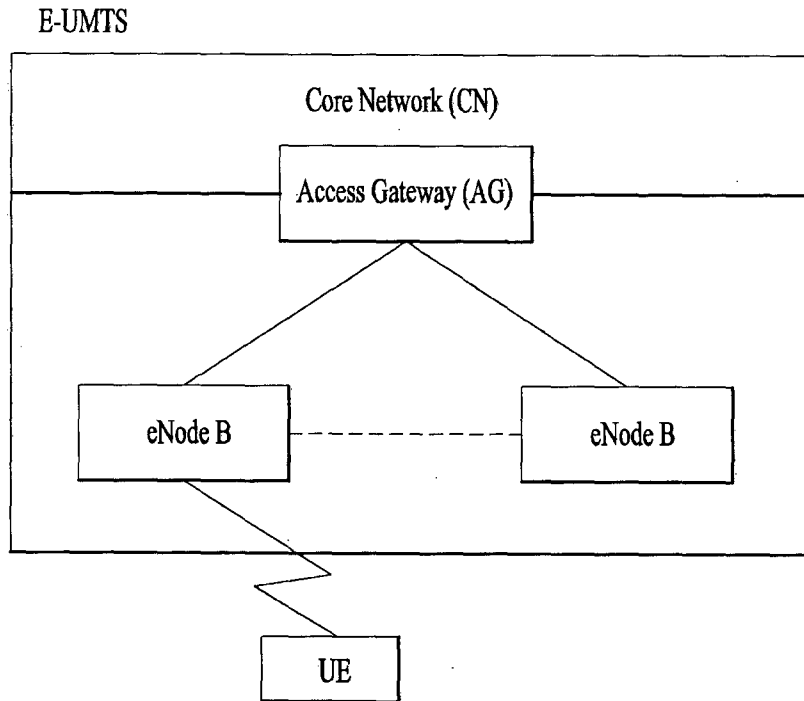

FIG. 2A

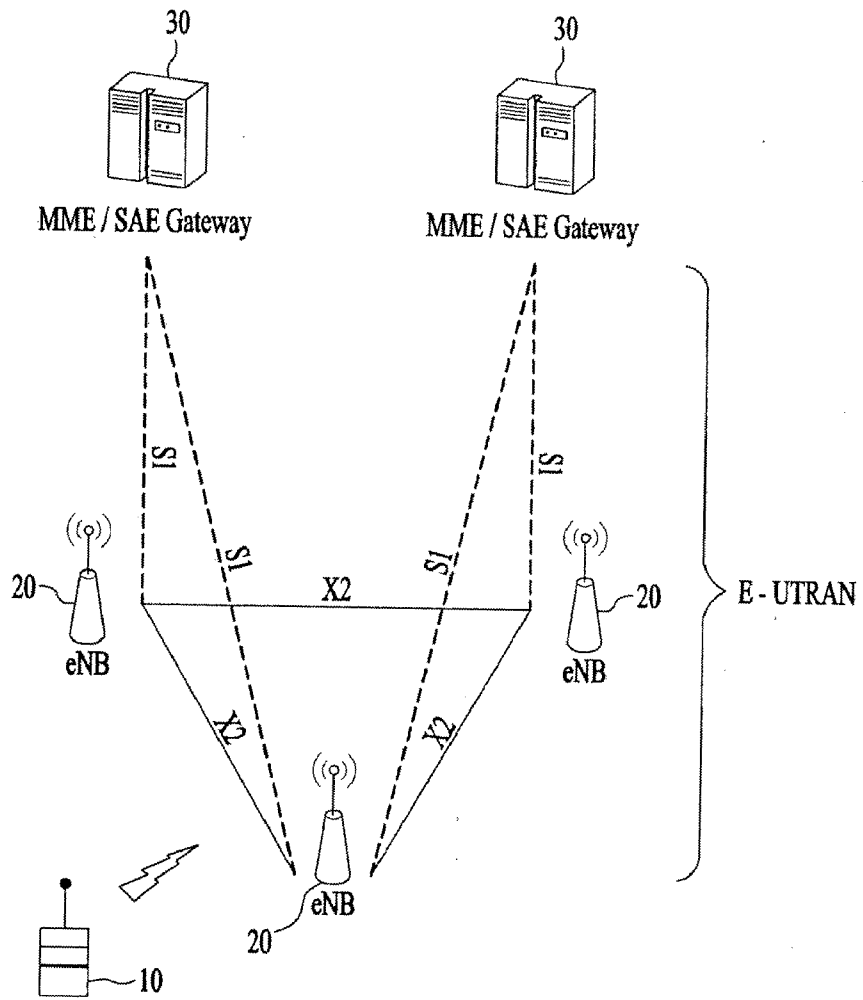

FIG. 2B

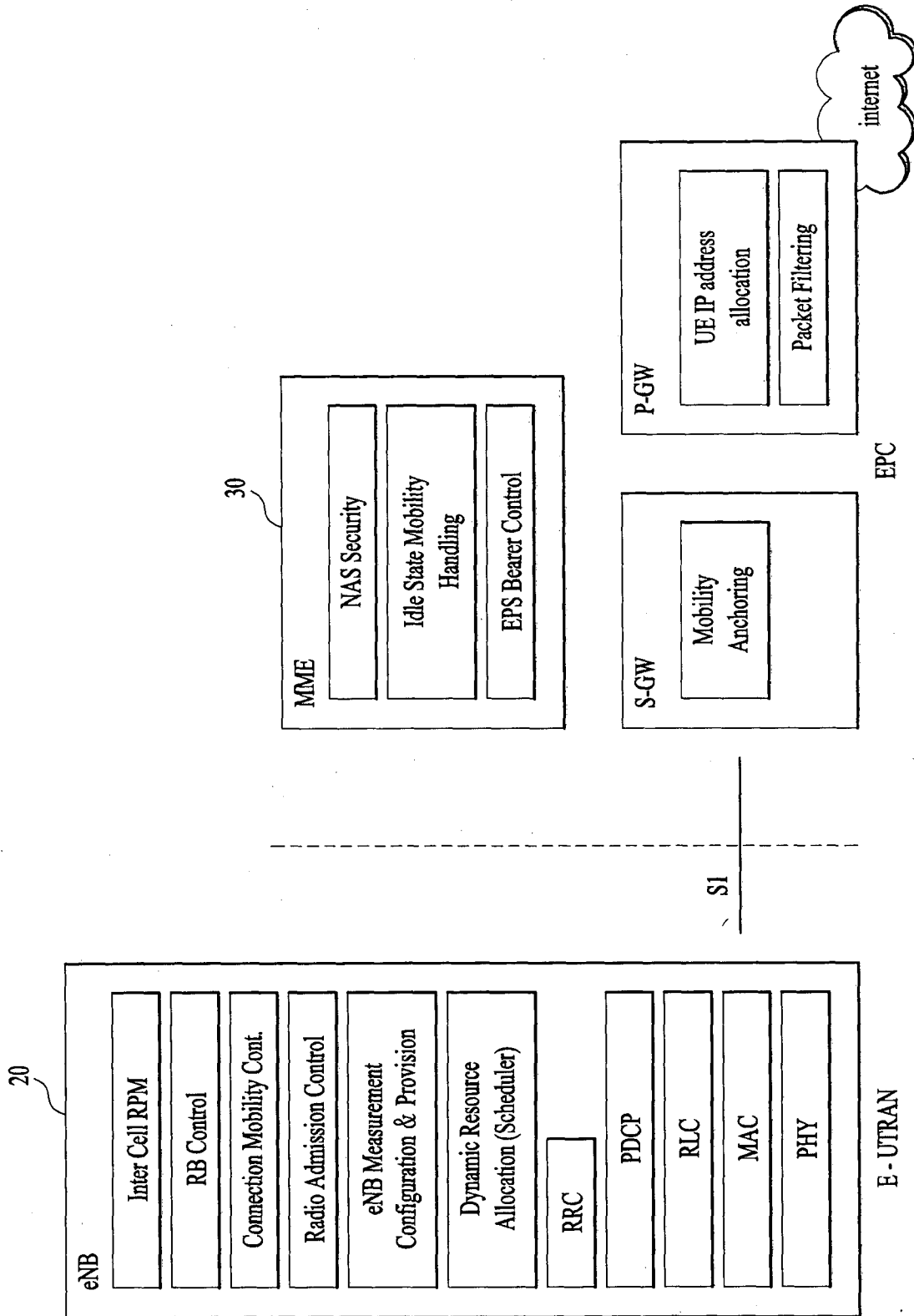
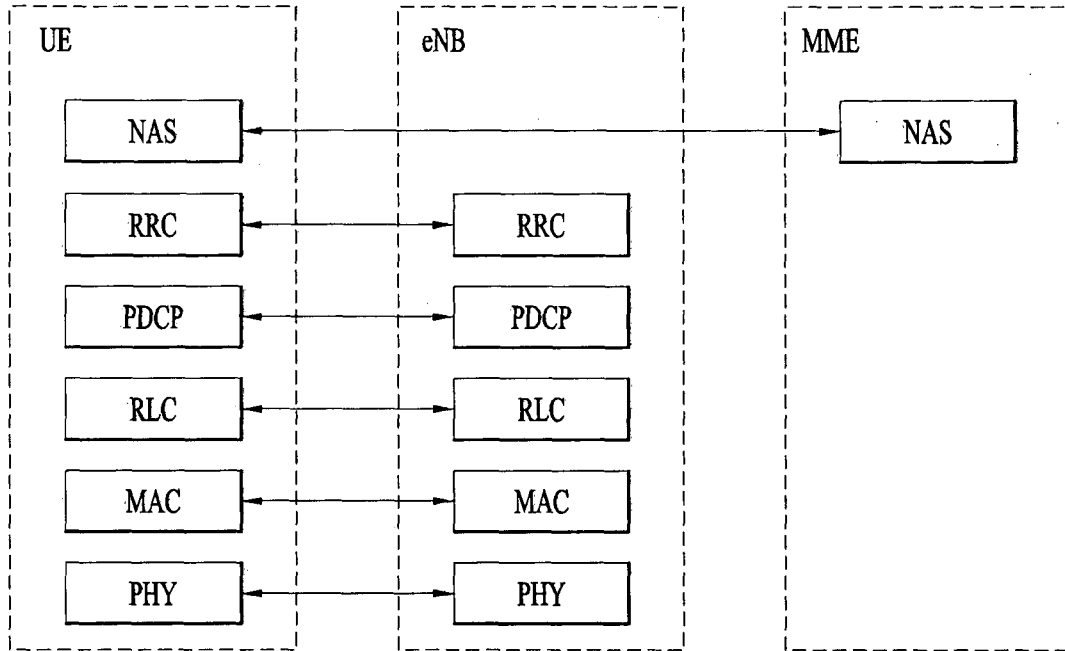
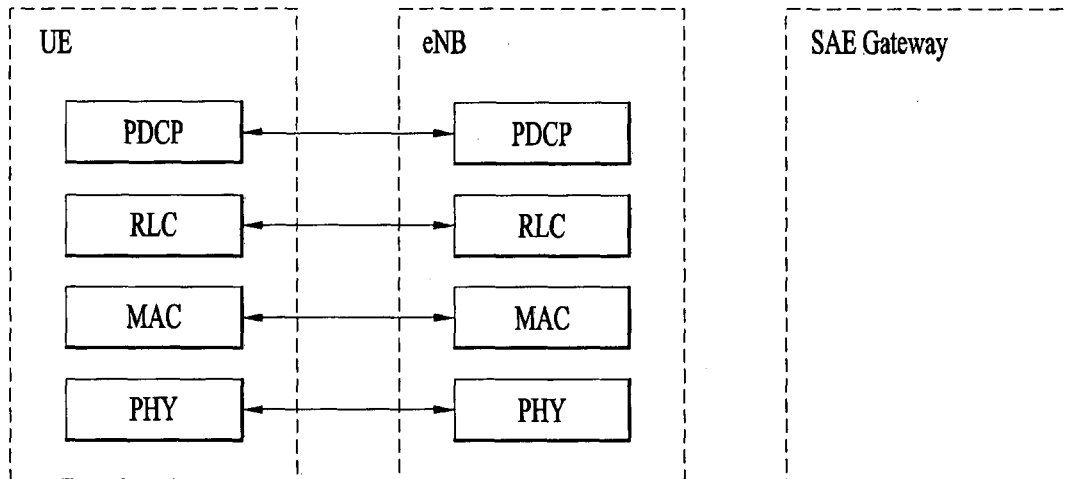

FIG. 3



(a) Control-Plane Protocol Stack



(b) User-Plane Protocol Stack

FIG. 4

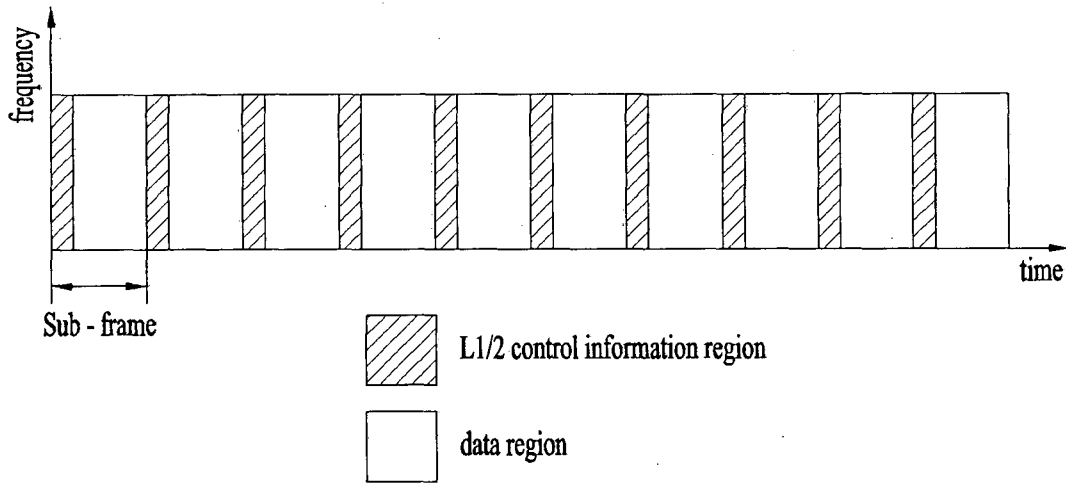

FIG. 5

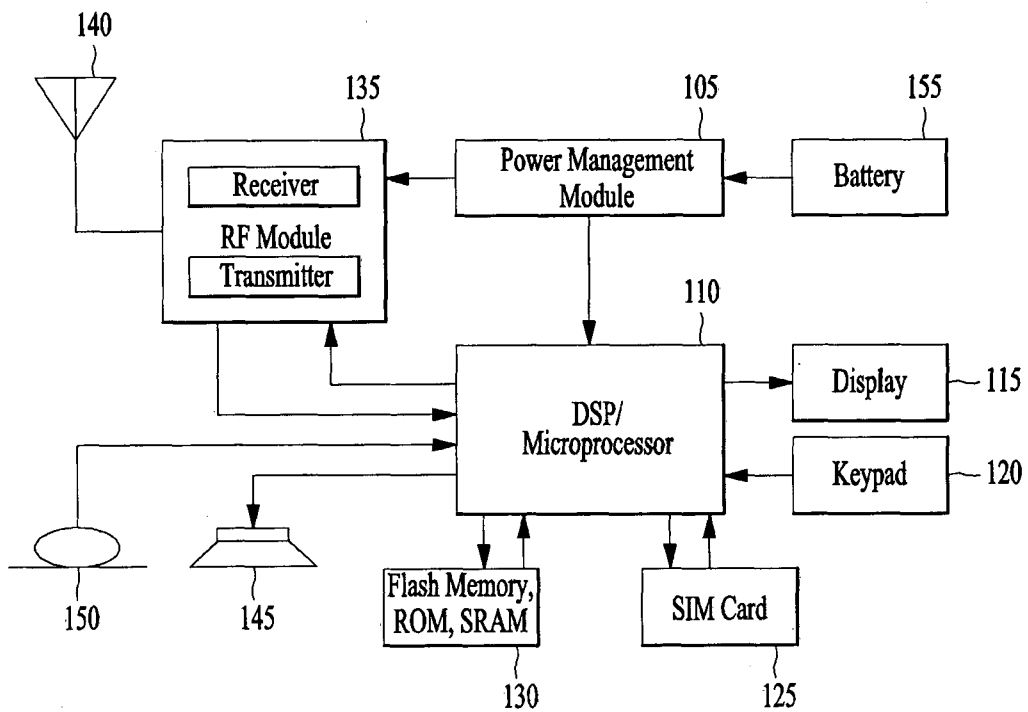

FIG. 6

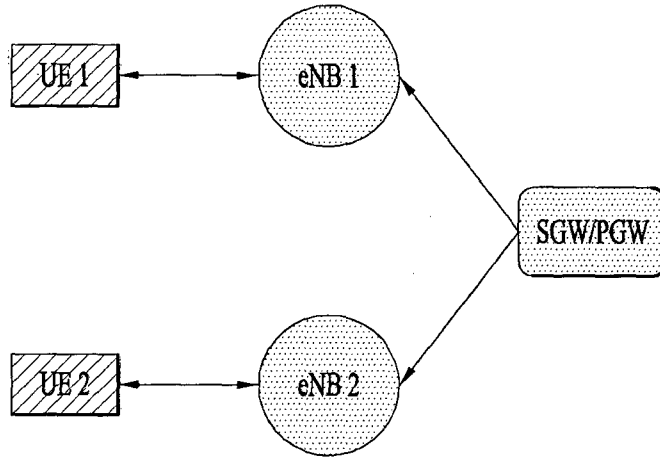

FIG. 7

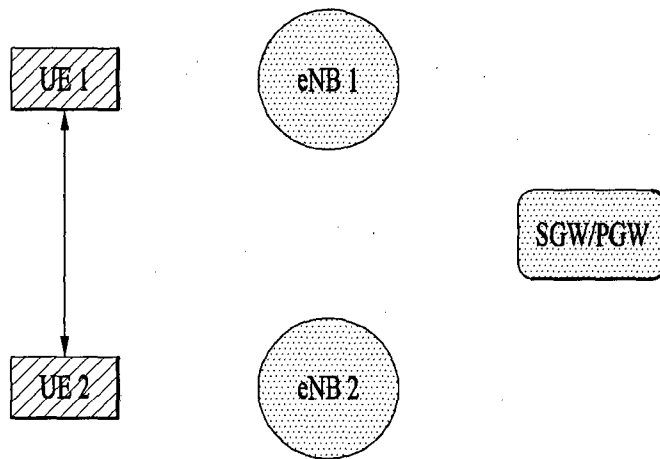

FIG. 8

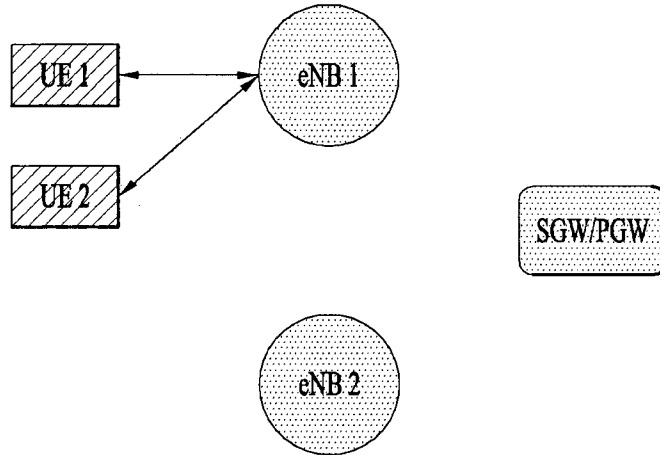

FIG. 9

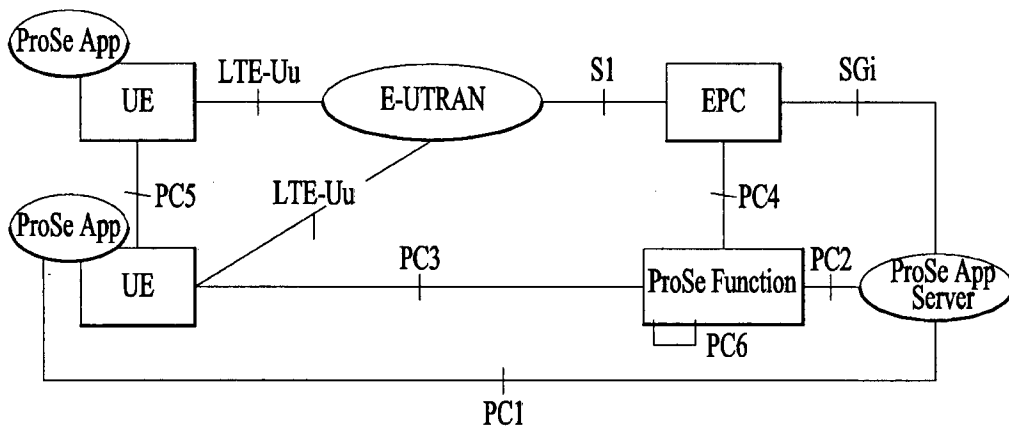

FIG. 10

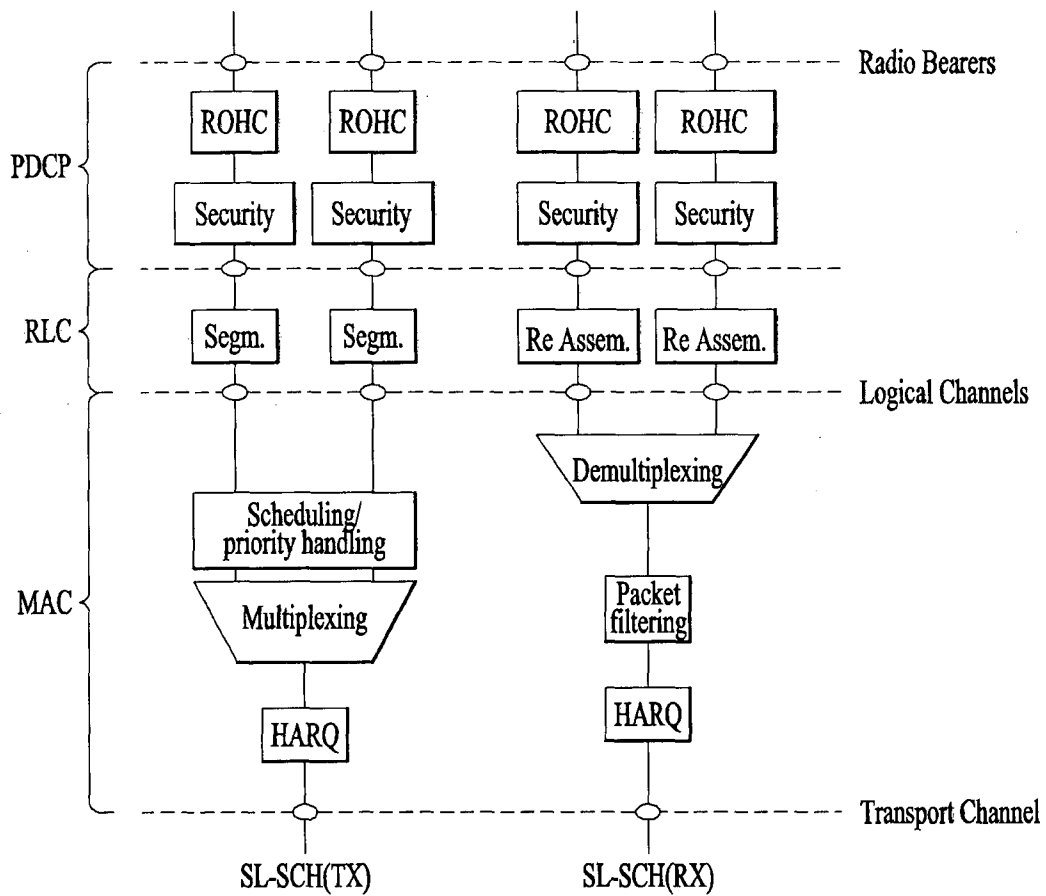

FIG. 11A

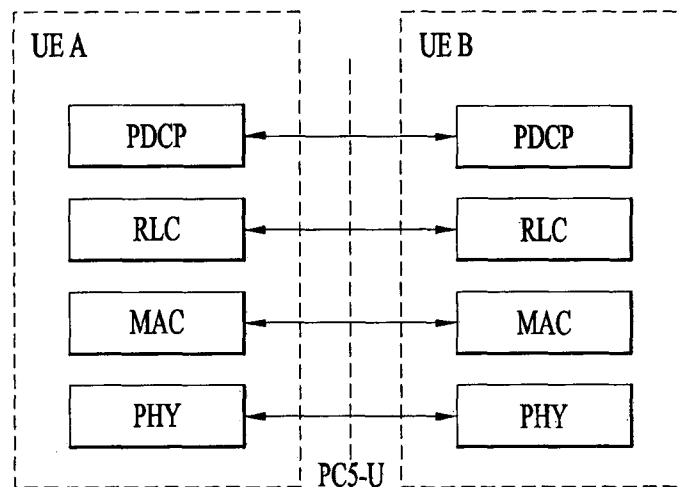

FIG. 11B

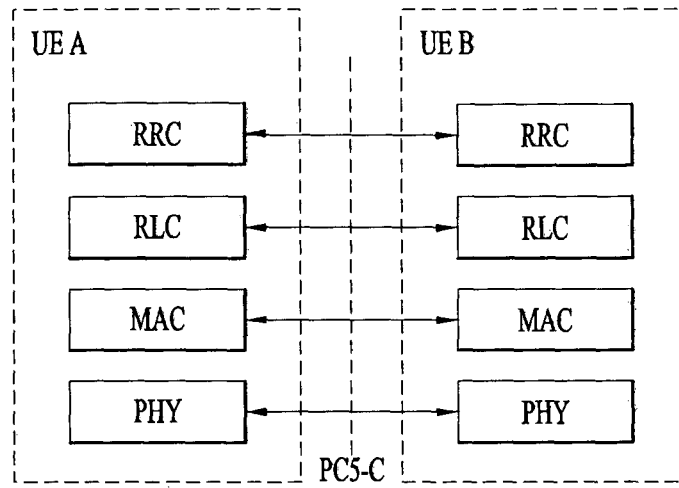

FIG. 12

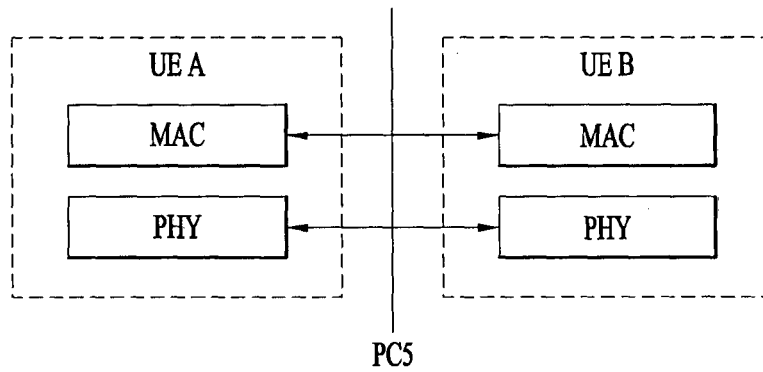

FIG. 13

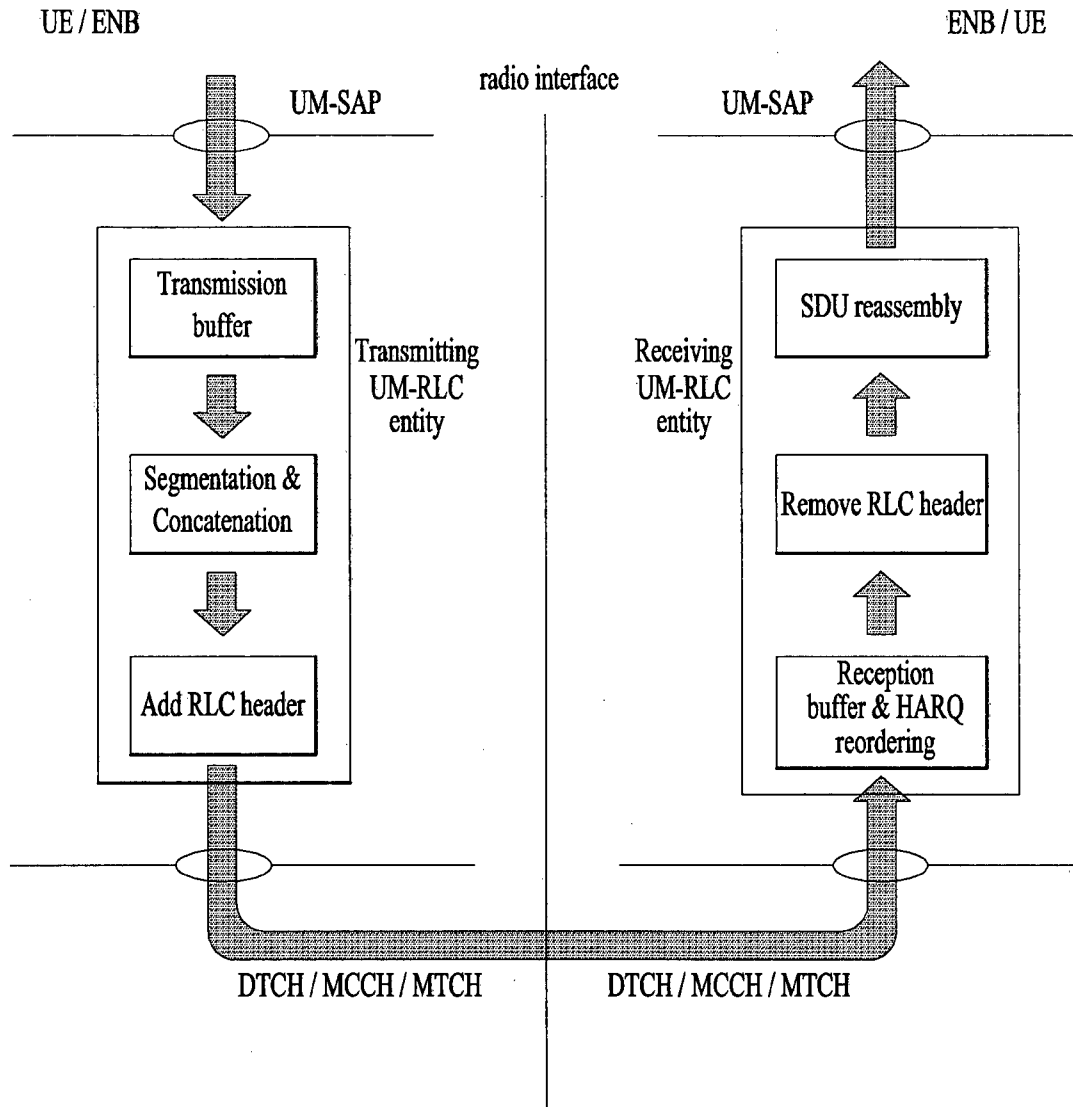

FIG. 14a

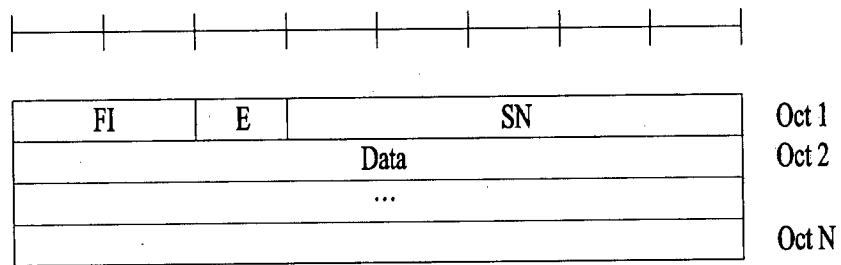

FIG. 14b

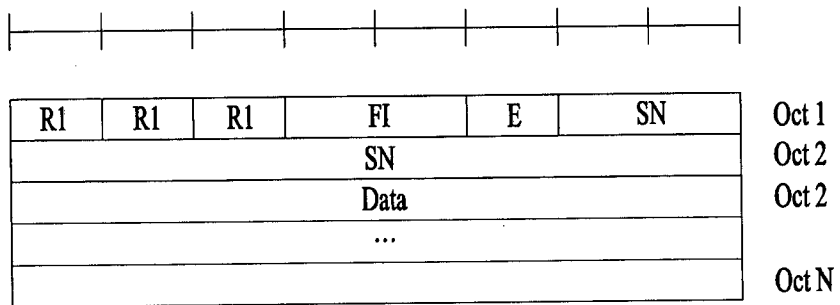

FIG. 14e

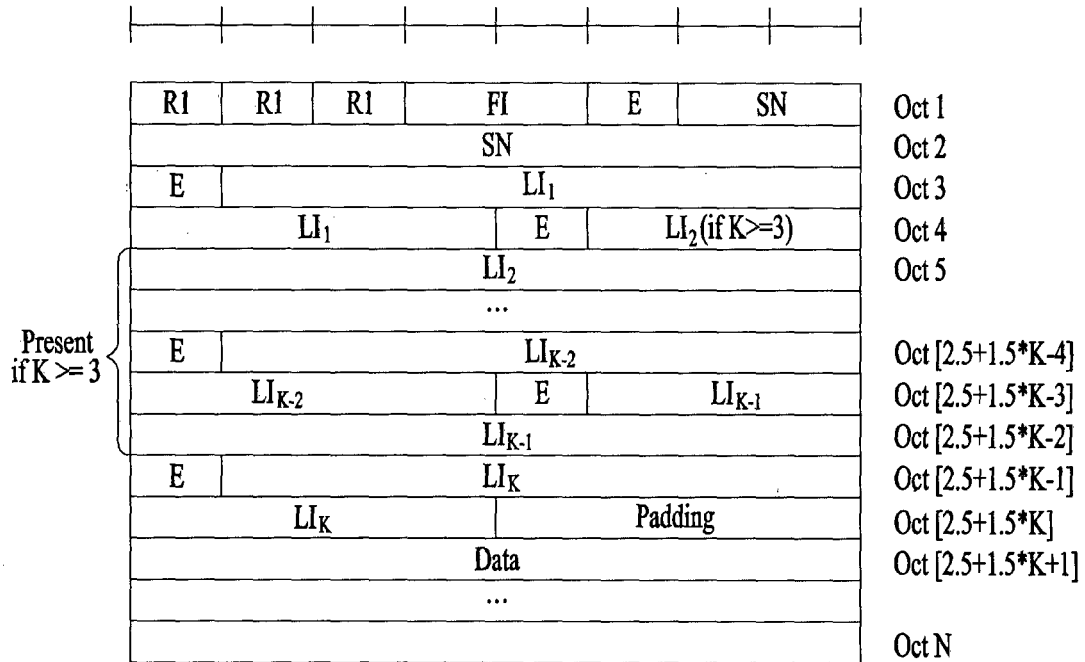

FIG. 14f

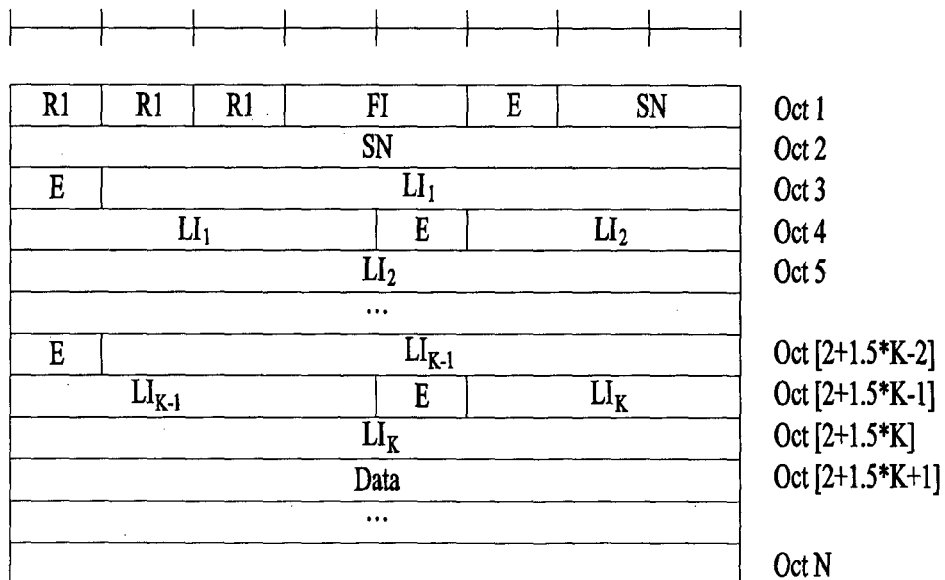

FIG. 15

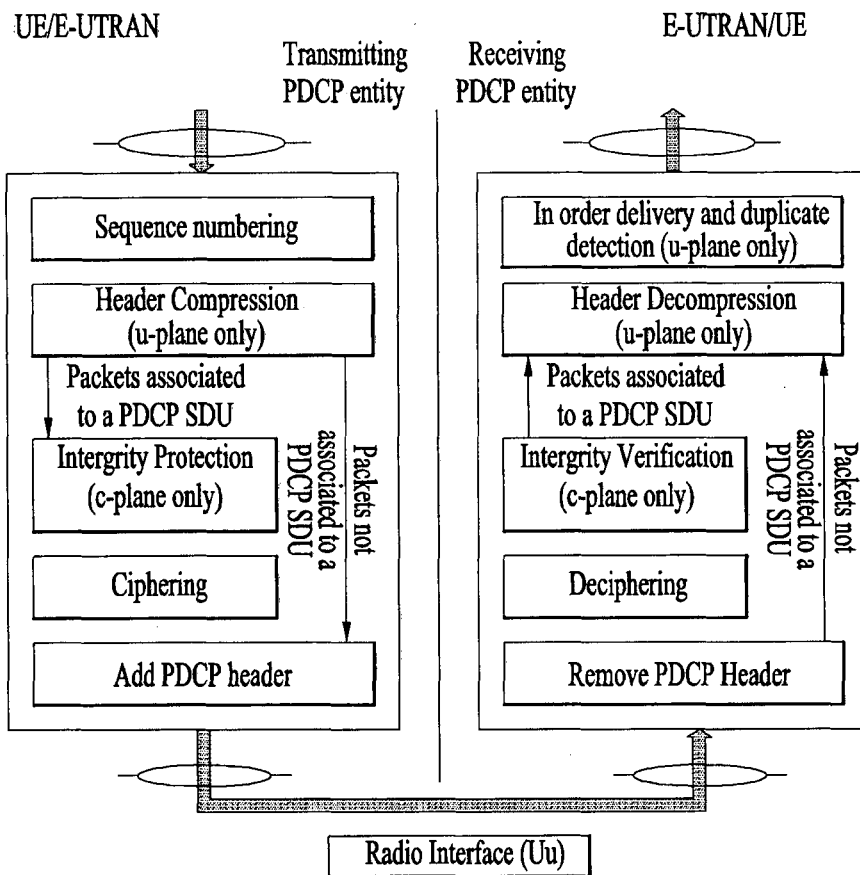

FIG. 16a

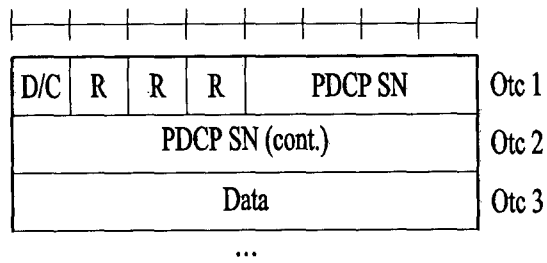

FIG. 16b

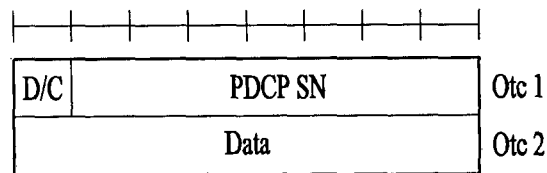

FIG. 17

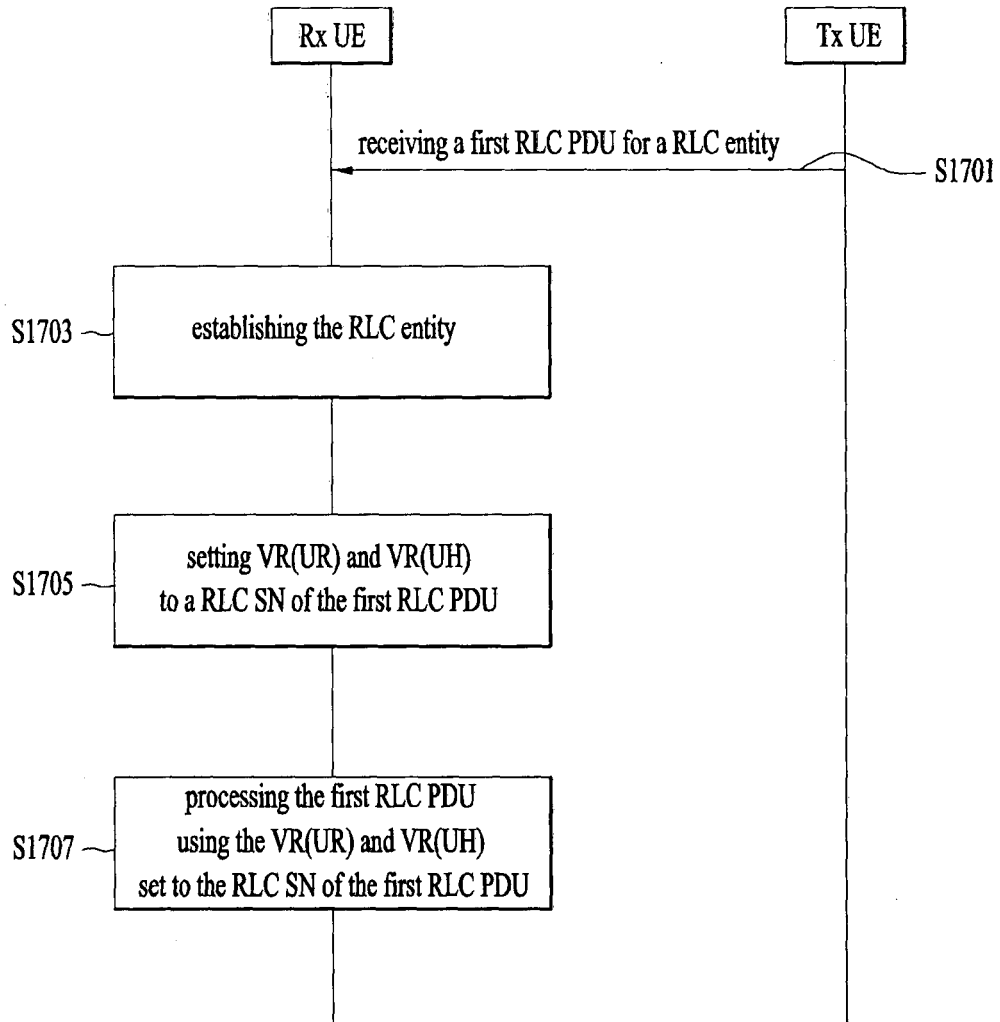
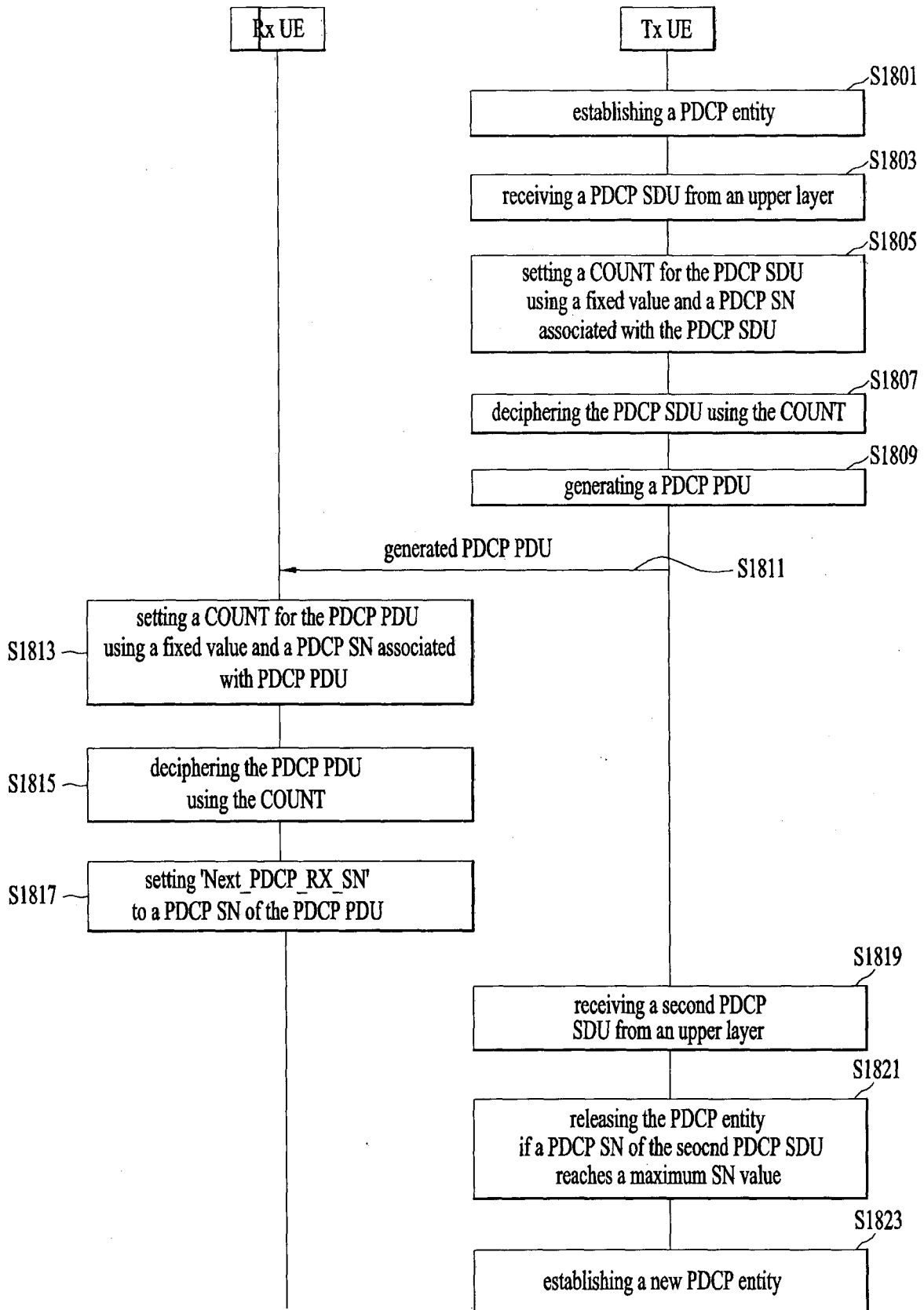

FIG. 18



A. CLASSIFICATION OF SUBJECT MATTER**H04L 29/08(2006.01)i**

According to International Patent Classification (IPC) or to both national classification and IPC

B. FIELDS SEARCHEDMinimum documentation searched (classification system followed by classification symbols)
H04L 29/08; H04J 3/26; H04Q 7/20; H04L 1/18; H04L 9/00; H04L 12/56Documentation searched other than minimum documentation to the extent that such documents are included in the fields searched
Korean utility models and applications for utility models
Japanese utility models and applications for utility modelsElectronic data base consulted during the international search (name of data base and, where practicable, search terms used)
eKOMPASS(KIPO internal) & Keywords: RLC PDU, initial value, state variable, RLC SN.**C. DOCUMENTS CONSIDERED TO BE RELEVANT**

Category*	Citation of document, with indication, where appropriate, of the relevant passages	Relevant to claim No.
Y	US 2008-0175249 A1 (SEUNG-JUNE YI et al.) 24 July 2008 See paragraphs [0024]-[0025], [0044], [0053]-[0057], [0118]-[0121]; and figure 1.	1-3,6-8
A		4-5,9-10
Y	US 7356146 B2 (SEUNG JUNE YI et al.) 08 April 2008 See column 4 line 30 - column 5 line 46, column 21 line 35 - column 23 line 36; claims 1, 8, 48; and figures 1, 4-5.	1-3,6-8
A	US 2007-0298781 A1 (SAM SHIAW-SHIANG JIANG) 27 December 2007 See paragraphs [0006]-[0008], [0018]-[0020]; and figures 1-3.	1-10
A	US 2005-0074024 A1 (SOENG-HUN KIM et al.) 07 April 2005 See paragraphs [0099]-[0105], [0112]-[0126]; and figures 16-17.	1-10
A	WO 2013-044982 A1 (NOKIA SIEMENS NETWORKS OY et al.) 04 April 2013 See page 11 line 13 - page 14 line 19; claim 1; and figure 1-2.	1-10

 Further documents are listed in the continuation of Box C. See patent family annex.

* Special categories of cited documents:

"A" document defining the general state of the art which is not considered to be of particular relevance

"E" earlier application or patent but published on or after the international filing date

"L" document which may throw doubts on priority claim(s) or which is cited to establish the publication date of another citation or other special reason (as specified)

"O" document referring to an oral disclosure, use, exhibition or other means

"P" document published prior to the international filing date but later than the priority date claimed

"T" later document published after the international filing date or priority date and not in conflict with the application but cited to understand the principle or theory underlying the invention

"X" document of particular relevance; the claimed invention cannot be considered novel or cannot be considered to involve an inventive step when the document is taken alone

"Y" document of particular relevance; the claimed invention cannot be considered to involve an inventive step when the document is combined with one or more other such documents, such combination being obvious to a person skilled in the art

"&" document member of the same patent family

Date of the actual completion of the international search

08 July 2015 (08.07.2015)

Date of mailing of the international search report

08 July 2015 (08.07.2015)

Name and mailing address of the ISA/KR

International Application Division
Korean Intellectual Property Office
189 Cheongsu-ro, Seo-gu, Daejeon Metropolitan City, 302-701,
Republic of Korea

Facsimile No. +82-42-472-7140

Authorized officer

KIM, Seong Woo

Telephone No. +82-42-481-3348



INTERNATIONAL SEARCH REPORT

Information on patent family members

International application No.

PCT/KR2015/003305

Patent document cited in search report	Publication date	Patent family member(s)	Publication date		
US 2008-0175249 A1	24/07/2008	AU 2005-324331 A1	21/09/2006		
		AU 2005-324331 A8	21/08/2008		
		AU 2005-324331 B2	14/02/2008		
		AU 2005-324331 B8	21/08/2008		
		BR PI0509268 A	04/09/2007		
		CN 101588231 A	25/11/2009		
		CN 101588231 B	21/11/2012		
		CN 1951052 A	18/04/2007		
		CN 1951052 B	30/05/2012		
		CN 1951052 C	18/04/2007		
		EP 1756999 A1	28/02/2007		
		EP 1756999 A4	24/11/2010		
		EP 1756999 B1	15/04/2015		
		JP 2007-533280 A	15/11/2007		
		JP 4570657 B2	27/10/2010		
		KR 10-1000699 B1	10/12/2010		
		KR 10-2005-0101482 A	24/10/2005		
		MX PA06010759 A	15/12/2006		
		RU 2006128799 A	27/05/2008		
		RU 2346403 C2	10/02/2009		
		UA 88467 C2	26/10/2009		
		US 2005-0270996 A1	08/12/2005		
		US 7633892 B2	15/12/2009		
		US 8023454 B2	20/09/2011		
		WO 2005-117317 A1	08/12/2005		
		ZA 200606842 A	30/04/2008		
		US 7356146 B2	08/04/2008	AT 532358 T	15/11/2011
				AU 2003-207130 A1	04/09/2003
				AU 2003-207130 B2	07/09/2006
				CN 1230025 C	30/11/2005
				CN 1449218 A	15/10/2003
				CN 1633762 A	29/06/2005
				CN 1633762 B	10/07/2013
CN 1633762 C	29/06/2005				
EP 1337123 A2	20/08/2003				
EP 1337123 A3	02/01/2004				
EP 1337123 B1	16/09/2009				
EP 1337125 A2	20/08/2003				
EP 1337125 A3	27/12/2006				
EP 1337125 B1	02/11/2011				
EP 1876855 A2	09/01/2008				
EP 1876855 A3	04/11/2009				
EP 1973371 A2	24/09/2008				
EP 1973371 A3	25/03/2009				
EP 1973372 A2	24/09/2008				
EP 1973372 A3	18/03/2009				
EP 2134109 A2	16/12/2009				
EP 2134109 A3	17/02/2010				

INTERNATIONAL SEARCH REPORT

Information on patent family members

International application No.

PCT/KR2015/003305

Patent document cited in search report	Publication date	Patent family member(s)	Publication date
		ES 2373710 T3	08/02/2012
		GB 2387510 A	15/10/2003
		GB 2387510 B	13/10/2004
		HK 1058590 A1	08/04/2005
		JP 2003-235070 A	22/08/2003
		JP 2005-518135 A	16/06/2005
		JP 2008-271583 A	06/11/2008
		JP 3826807 B2	27/09/2006
		JP 4269161 B2	27/05/2009
		JP 4995146 B2	08/08/2012
		KR 10-0750544 B1	20/08/2007
		KR 10-0765123 B1	11/10/2007
		KR 10-0809898 B1	07/03/2008
		KR 10-2003-0068741 A	25/08/2003
		MX PA04007854 A	15/10/2004
		RU 2004127673 A	27/01/2006
		RU 2287228 C2	10/11/2006
		UA 77049 C2	15/10/2004
		US 2003-0153310 A1	14/08/2003
		US 2003-0157927 A1	21/08/2003
		US 2008-0293416 A1	27/11/2008
		US 2010-0178923 A1	15/07/2010
		US 7706537 B2	27/04/2010
		US 7869815 B2	11/01/2011
		US 7889867 B2	15/02/2011
		WO 03-069806 A1	21/08/2003
		ZA 200405611 A	14/10/2005
US 2007-0298781 A1	27/12/2007	CN 101094474 A	26/12/2007
		CN 101098508 A	02/01/2008
		EP 1871137 A2	26/12/2007
		EP 1871138 A2	26/12/2007
		JP 2008-005508 A	10/01/2008
		JP 2008-005510 A	10/01/2008
		KR 10-0913373 B1	20/08/2009
		KR 10-2007-0121599 A	27/12/2007
		KR 10-2007-0121600 A	27/12/2007
		TW 200803273 A	01/01/2008
		US 2008-019515 A1	24/01/2008
US 2005-0074024 A1	07/04/2005	CN 1833413 A	13/09/2006
		DE 602004006679 T2	04/10/2007
		EP 1505793 A1	09/02/2005
		EP 1505793 B1	30/05/2007
		EP 1686740 A1	02/08/2006
		JP 2007-502070 A	01/02/2007
		KR 10-0617687 B1	28/08/2006
		KR 10-2005-0019028 A	28/02/2005
		WO 2005-015857 A1	17/02/2005

INTERNATIONAL SEARCH REPORT

Information on patent family members

International application No.

PCT/KR2015/003305

Patent document cited in search report	Publication date	Patent family member(s)	Publication date
WO 2013-044982 A1	04/04/2013	EP 2761802 A1	06/08/2014