



(51) International Patent Classification:
H04W 74/08 (2009.01)

(21) International Application Number:
PCT/US2013/044543

(22) International Filing Date:
6 June 2013 (06.06.2013)

(25) Filing Language: English

(26) Publication Language: English

(30) Priority Data:
61/679,627 3 August 2012 (03.08.2012) US
13/687,838 28 November 2012 (28.11.2012) US

(71) Applicant: INTEL CORPORATION [US/US]; 2200 Mission College Blvd., Santa Clara, California 95054 (US).

(72) Inventors: LI, Honggang; Raycom A-8, No.2 Kexueyuan South Road, Haidian District, Beijing 100080 (CN). LI, Qinghua; 5117 Chiltern Lane, San Ramon, California 94582 (US). FWU, Jong-Kae; 1519 Dominion Ave., Sunnyvale, California 94087 (US). CHEN, Xiaogang; KeXueYuan South Road 2# RYC 8F, Beijing 100080 (CN). ZHU, Yuan; Room 605, Building 16, Mo Li Yuan, Bei Yuan Jia Yuan, Chaoyang, Beijing 100013 (CN).

(74) Agents: MADDEN, Robert B. et al.; Schwegman, Lundberg & Woessner, P.A., P.O. Box 2938, Minneapolis, Minnesota 55402 (US).

(81) Designated States (unless otherwise indicated, for every kind of national protection available): AE, AG, AL, AM, AO, AT, AU, AZ, BA, BB, BG, BH, BN, BR, BW, BY, BZ, CA, CH, CL, CN, CO, CR, CU, CZ, DE, DK, DM, DO, DZ, EC, EE, EG, ES, FI, GB, GD, GE, GH, GM, GT, HN, HR, HU, ID, IL, IN, IS, JP, KE, KG, KN, KP, KR, KZ, LA, LC, LK, LR, LS, LT, LU, LY, MA, MD, ME, MG, MK, MN, MW, MX, MY, MZ, NA, NG, NI, NO, NZ, OM, PA, PE, PG, PH, PL, PT, QA, RO, RS, RU, RW, SC, SD, SE, SG, SK, SL, SM, ST, SV, SY, TH, TJ, TM, TN, TR, TT, TZ, UA, UG, US, UZ, VC, VN, ZA, ZM, ZW.

(84) Designated States (unless otherwise indicated, for every kind of regional protection available): ARIPO (BW, GH, GM, KE, LR, LS, MW, MZ, NA, RW, SD, SL, SZ, TZ, UG, ZM, ZW), Eurasian (AM, AZ, BY, KG, KZ, RU, TJ, TM), European (AL, AT, BE, BG, CH, CY, CZ, DE, DK, EE, ES, FI, FR, GB, GR, HR, HU, IE, IS, IT, LT, LU, LV, MC, MK, MT, NL, NO, PL, PT, RO, RS, SE, SI, SK, SM, TR), OAPI (BF, BJ, CF, CG, CI, CM, GA, GN, GQ, GW, KM, ML, MR, NE, SN, TD, TG).

Published:

— with international search report (Art. 21(3))

(54) Title: HIGH EFFICIENCY DISTRIBUTED DEVICE-TO-DEVICE (D2D) CHANNEL ACCESS

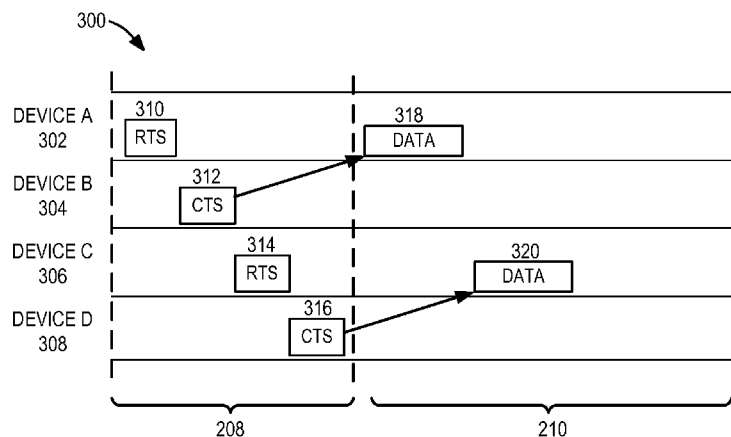

FIG. 3

(57) Abstract: Techniques for facilitating device-to-device (D2D) communications using a high efficiency distributed channel access scheme are generally described herein. In some examples, a communication zone allocated for wireless D2D communications is divided into resource contention and scheduled transmission portions. The resource contention segment may be used to transmit a request message from a transmitting device to a receiving device (a request-to-send message), and transmit a response to the request message from the receiving device to the transmitting device (a clear-to-send message). The response can indicate a time for the data transmission to occur during the scheduled transmission segment. During the scheduled transmission segment, the scheduled data transmission and other D2D data transmissions among the various devices will be performed. In further examples, contention access techniques may be used during the resource contention segment to manage access to the resource channel.

WO 2014/021990 A1

HIGH EFFICIENCY DISTRIBUTED
DEVICE-TO-DEVICE (D2D) CHANNEL ACCESS

5

PRIORITY APPLICATION

[0001] This application claims the benefit of priority to United States Patent Application Serial Number 13/687,838, filed on November 28, 2012, which claims the benefit of priority to United States Provisional Patent
10 Application Serial Number 61/679,627, filed on August 3, 2012, both of which are hereby incorporated by reference in their entireties.

TECHNICAL FIELD

[0002] Embodiments pertain to operations and communications performed by
15 communicating devices in wireless networks. Some embodiments relate to device-to-device (D2D) communications between devices facilitated by a wireless network.

BACKGROUND

20 **[0003]** D2D wireless communication techniques may be used to offload data communications and perform peer-to-peer communications among mobile devices and networks. D2D communications between mobile devices (e.g., user equipment (UEs)) are generally designed to complement the use of centralized communications from a wireless base station (e.g., centralized station-to-mobile
25 communications from an evolved NodeB (eNodeB) in a 3GPP Long Term Evolution/Long Term Evolution-Advanced (LTE/LTE-A) network). D2D communications can reuse spectrum in licensed communication bands and channels used by a centralized network. Complexity exists, however, when scheduling and coordinating the D2D communications with the centralized
30 network and independently operating devices.

[0004] For example, with certain 3GPP LTE/LTE-A standards, a time-frequency zone (“D2D zone”) may be allocated by the eNodeB for D2D

communications. Within the D2D zone, contention-based channel access techniques may be used to manage distributed device access to D2D communication resources. Contention-based channel access helps to minimize the scheduling and control overhead on the common interface used by the eNodeB and multiple D2D UEs. Some contention-based methods, such as Carrier Sense Multiple Access with Collision Avoidance (CSMA/CA), are not efficient, however in terms of the contention overhead and power consumption due to packet collisions and channel monitoring.

10 BRIEF DESCRIPTION OF THE DRAWINGS

[0005] FIG. 1 includes a diagram of a D2D configuration for wireless communications among carrier network-connected devices according to a further described example.

15 [0006] FIG. 2A illustrates a block diagram of a D2D communication space (“D2D Zone”) allocated in a wireless communication frame according to a further described example.

[0007] FIG. 2B illustrates a block diagram of a D2D communication space (“D2D Zone”) having random access contention and scheduled communication divisions according to a further described example.

20 [0008] FIG. 3 illustrates a time-based diagram of D2D communications including random access contention and scheduled communications for multiple devices according to a further described example.

[0009] FIG. 4 illustrates an operation flow for D2D communications including random access contention and scheduled communications between two devices according to a further described example.

[0010] FIG. 5 illustrates a flowchart for a wireless communication device to perform a D2D communication using a contention and scheduled communication procedure according to a further described example.

30 [0011] FIG. 6A illustrates an example method for facilitating D2D channel access for a D2D data transmission according to a further described example.

[0012] FIG. 6B illustrates an example method for facilitating D2D channel access for a D2D data reception according to a further described example.

[0013] FIG. 7 illustrates an example mobile device on which the configurations and techniques described herein may be deployed.

[0014] FIG. 8 illustrates an example computer system that may be used as a computing platform for the computing devices described herein.

5

DETAILED DESCRIPTION

[0015] The following description and the drawings sufficiently illustrate specific embodiments to enable those skilled in the art to practice them. Other embodiments may incorporate structural, logical, electrical, process, and other
10 changes. Portions and features of some embodiments may be included in, or substituted for, those of other embodiments. Embodiments set forth in the claims encompass all available equivalents of those claims.

[0016] Various techniques and configurations described herein provide for an efficient contention-based channel access scheme for D2D wireless
15 communications. This contention-based channel access scheme may be deployed in assigned or allocated D2D communication zones or segments, such as in a D2D communication zone allocated in a carrier-based wireless communication network. The contention-based channel access scheme described herein for the D2D communications also incorporates use of
20 scheduling techniques to coordinate the performance of the data transferred requested by the contention procedure.

[0017] In one example, the D2D communication zone is allocated into a resource allocation segment (e.g., a Random Access Channel (RACH) time period) and a scheduled communication segment (e.g., a Scheduled (SCH) time
25 period). During the resource allocation segment, a series of request and acknowledgment messages such as a request-to-send (RTS) message and clear-to-send (CTS) message may be exchanged between devices. The RTS message may be sent by a transmitting device in the resource allocation segment to request resources in the D2D zone to perform a wireless transmission. The CTS
30 message may be sent in response to the RTS message, to indicate a scheduled time (in the scheduled communication segment) when a receiving device will monitor the resource to receive the wireless transmission. At the scheduled time

during the scheduled communication segment, the transmitting device and the receiving device can perform the D2D wireless communication.

5 [0018] The D2D communication techniques described herein provide a joint contention and scheduling mechanism that addresses deficiencies of exclusive contention or scheduling techniques. One commonly used contention technique, CSMA/CA, is deployed in communications for wireless networks such as IEEE 802.11 standard-compliant implementations. CSMA/CA implementations typically use a backoff counter to wait a random number of slots to help find an opportunity to send the data packet. If the channel is idle, then a packet is sent.

10 [0019] The D2D communication technique described herein enables the actual data transmission to be scheduled and reserved. This ensures that a particular data packet can be transmitted without interference, while using contention-based techniques to request the scheduling. This enables a method which can transform the original contention mechanism into a distributed
15 scheduling mechanism, to cause less contention and network pollution. Further, use of the distributed scheduling mechanism enables multiple pairs of devices to exchange data in a scheduled window. Information from the scheduling window can be used to further coordinate power usage, communications, and other aspects of the D2D wireless network.

20 [0020] FIG. 1 illustrates a D2D networking configuration 100 for wireless communications among carrier network-connected devices 104A, 104B, 104C according to a further described example. As illustrated, a carrier-based network (e.g., a LTE/LTE-A cell network operating according to a standard from a 3GPP standards family) is established by a carrier network system 102 (e.g., an
25 eNodeB) with mobile devices 104A, 104B, 104C (e.g., user equipment (UE)). The carrier-based network includes network connections 106A, 106B, 106C to the mobile devices 104A, 104B, 104C, respectively. The mobile devices 104A, 104B, 104C are illustrated as conforming to a variety of form factors, including a smartphone 104A, a mobile phone handset 104B, and a personal computer (PC)
30 104C having an integrated or external wireless network communication device.

[0021] The D2D communications may be performed among the various mobile devices 104A, 104B, 104C using the contention and scheduling techniques for D2D connections described herein. Pairs of D2D-capable

communication devices can talk to each other, and may be co-located in a same area. Specifically, a D2D connection 108 may be established between smartphone 104A and mobile phone 104B; a D2D connection 110 may be established between mobile phone 104B and personal computer 104C; and a
5 D2D connection 112 may be established between smartphone 104A and personal computer 104C.

[0022] The carrier-based network controlled by the carrier network system 102 may be used to facilitate operations of the D2D connections 108, 110, 112. The carrier-based network (and various devices, subsystems, and components
10 within the carrier-based network, such as an eNodeB) may schedule or coordinate a communication window and timing for allowed D2D capabilities. The carrier network system 102 may also communicate availability and connection details among the various mobile devices 104A, 104B, 104C, and indicate the type of data to be communicated using the D2D connections, or
15 when usage of the D2D connections is required or encouraged. The D2D connections 108, 110, 112 may be conducted among the receiving devices 104A, 104B, 104C using the same or different communication frequencies and spectrum as that of the carrier-based network. This may include licensed or unlicensed spectrum using the same network protocol (e.g., a network protocol
20 operating according to a LTE, LTE-A, or other 3GPP standard) or other network protocols (e.g., a network protocol operating according to a standard from an IEEE 802.11 or 802.16 standards family, or a Bluetooth standard promulgated from the Bluetooth Special Interest Group).

[0023] FIG. 2A illustrates a block diagram of a D2D communication space allocated in a wireless communication frame 200 according to a further
25 described example. As depicted, the wireless communication frame 200 may include a downlink segment 202, including a set of downlink subframes, and an uplink segment 204, including a series of uplink subframes. The uplink segment 204 may be further segmented to include resources allocated for D2D
30 communications. As illustrated, this segment allocated for D2D communications is referred to herein as the “D2D Zone” 206. Any D2D wireless transmissions among the various mobile devices 104A, 104B, 104C may be configured to start and end within the D2D Zone 206.

[0024] FIG. 2B illustrates a block diagram of an example D2D communication space (the D2D Zone 206) having random access contention and scheduled communication divisions according to a further described example. In a frame-based time-frequency area, the D2D Zone 206 may be defined and partitioned in a time domain as shown in FIG. 2B. The random access contention segment of the D2D Zone 206 is referred to herein as the D2D random access channel "D2D RACH" segment 208. The scheduled communication segment of the D2D Zone 206 is referred to herein as the D2D shared channel "D2D SCH" segment 210. Although not illustrated, the D2D Zone 206 also may be further segmented or partitioned for other purposes.

[0025] In one example implementation, all contentions for D2D communication resource occur only in the D2D RACH segment 208. This results in only a small number of possible D2D devices (the winners of the contention) actively communicating in the D2D SCH segment 210. Use of a contention resource in the D2D RACH segment 208 followed by scheduling in the D2D SCH segment 210 enables devices to effectively coordinate operations, particularly where a large number of potential devices may be communicating.

[0026] Limiting contention to the D2D RACH segment 208 and actual data transmissions to the D2D SCH segment 210 may be used to retain the flexibility of contention-based D2D communication, while enabling the reduction of power consumption for many devices. For example, D2D devices not involved with a scheduled communication may choose to enter a power-saving or reduced communication mode during the duration of the D2D SCH segment 210. Likewise, D2D devices which are involved with a scheduled communication during only a portion of the D2D SCH segment 210 may choose to wake from a low power state on an as-needed basis (and re-enter the low power state) according to the schedule.

[0027] In contrast, the power consumption of devices implementing various contention techniques such as CSMA/CA may be much higher than with the presently described technique. This is because with the use of CSMA/CA, each active device is generally required to be active at all times, to detect the received packets over the wireless channel (and prevent the device from missing a packet addressed to it). Scheduling multiple D2D transmissions, one at a time within a

scheduling window, enables many D2D devices to reduce power and channel monitoring requirements.

[0028] FIG. 3 illustrates a time-based diagram 300 of D2D communications including random access contention and scheduled communications for multiple devices 302, 304, 306, 308 (in the D2D Zone 206 or other designated D2D communication time) according to a further described example. As depicted, Device A 302 and Device C 306 each are intended to schedule transmissions (318, 320) to Device B 304 and Device D 308 respectively.

[0029] During the D2D RACH segment 208, all active D2D devices 302, 304, 306, 308 monitor the channel for potential transmission or reception. In the example of FIG. 3, there is a request-to-send message 310 transmitted by Device A 302 to indicate a request to perform a data transmission to Device B 304, and a request-to-send message 314 transmitted by Device C 306 to indicate a request to perform a data transmission to Device D 308. These request-to-send messages 310, 314 used to invoke responses in the form of a clear-to-send message 312 from Device B 304, and a clear-to-send message 316 from Device D 308.

[0030] During the D2D RACH Segment 208, the device implements a contention-based technique to manage channel access for multiple transmissions over the wireless communication medium. This may be performed through the use of a collision avoidance technique with the generation of a backoff time for a busy channel, similar to use of a CSMA/CA technique. When the backoff time expires, and time remains within the D2D RACH segment 208, a transmitting device may send a request-to-send message to a receiving device. If a receiving device receives the request-to-send message successfully, the receiving device may respond by a clear-to-send message.

[0031] The clear-to-send response message is distinguishable from existing CSMA/CA mechanisms used in IEEE 802.11 or other wireless network standards, due to the inclusion of an explicit transmission or scheduling time in the response message. The transmission time, denoted as time-to-send, may be specified in a clear-to-send message such that a transmitting device knows when to turn on its transmitter to send the packet (e.g., with Device A's data transmission 318 during D2D SCH segment 210). Further, the clear-to-send

message may be used to inform other listening/receiving devices in the network whether the scheduled channel will be in use by the communicating devices.

[0032] When a contention mechanism indicates that previous use of the contention channel is now concluded (such as a backoff time expires for Device C 306 in the D2D RACH channel 208, and the channel is detected as being available), Device C 306 may send a request-to-send message 314 to Device D 316. A time-to-send indication is specified in this message. If Device D 308 receives the request-to-send message successfully, Device D 308 will respond by a clear-to-send message 316 with a time-to-send indication to inform both Device C 306 and other listening devices (e.g., Device A 302, Device B 304) of the transmission time for Device C's data transmission 320.

[0033] The size of the request-to-send/clear-to-send message packet may be configured to be small to conserve bandwidth and resources. The request-to-send/clear-to-send message may be configured to only provide a simple indication of how much time to reserve (in the request-to-send packet) and what time is reserved (in the clear-to-send response packet). Device neighbors of the transmitting and receiving devices can also observe the request-to-send/clear-to-send packets to learn about the scheduling and specific time reservation. In contrast, with use of request-to-send/clear-to-send packets in IEEE 802.11 standard networks, there is no such information on scheduling or timing within the clear-to-send message packet. Rather, the clear-to-send message in IEEE 802.11 standard networks is used to invoke immediate transmission of data and not a scheduled transmission of data in a separate time window.

[0034] Thus, request-to-send/clear-to-send packets are exchanged in the D2D RACH segment 208, and scheduling is established for the actual data transmission(s) over the wireless channel in the D2D SCH segment 210. This enables active and observing devices to know exact transmission times and keep track of channel usage. During the duration of the D2D SCH segment 210, only successfully scheduled devices involved in transmission and receipt in the D2D RACH segment 208 need to be powered and active at the scheduled time. For example, when it is the time for Devices A and B 302, 304 to transmit and receive with data communication 318, Devices C and D 306, 308 can enter or maintain a sleep/power-saving mode to minimize power consumption.

Likewise, Devices A and B 302, 304 can enter or maintain a sleep/power-saving mode during the time that devices C and D 306, 308 communicate with data transmission 320.

5 [0035] FIG. 4 illustrates an operation flow 400 for D2D communications including random access contention and scheduled communications between two devices (Device A 302 and Device B 304) according to a further described example. During the D2D RACH segment 208, both Device A 302 and Device B 304 are configured to listen to the wireless communication medium for any signaling.

10 [0036] Device A 302 obtains access to the D2D RACH segment 208 using a contention access technique. As illustrated, this may include a CSMA/CA-type of backoff technique, including obtaining a backoff time (operation 402) and waiting for the backoff time to expire (operation 404). Device A 302 sends the request-to-send (RTS) message (operation 406) to Device B 304, repeating the
15 RTS message until acknowledged (operation 408) or until a specified number of tries is exceeded (unless the D2D RACH segment 208 has concluded).

[0037] Device B 304 responds by sending a clear-to-send message (operation 412), indicating a designated time-to-send (operation 410) of when Device A 302 can start to send data packets of the data transmission. Upon the conclusion
20 of the D2D RACH segment 208 and the start of the D2D SCH segment 210, Device A 302 and Device B 304 may enter sleep modes until the designated time to send (operation 414) and time to receive (operation 416) respectively. At the time to send (operation 418) and the time to receive (operation 420), the data can be transmitted over the wireless medium from Device A 302 to Device B 304.

25 [0038] The time to send (designated in operation 410) may be indicated by an offset time t_1 from the start of the D2D SCH segment 210. The offset time t_1 can be defined in some resolved time unit of the carrier network, e.g. a number of time slots. (Likewise, when another device, such as Device D 308 of FIG. 3, sends a clear-to-send response, the clear-to-send response message may indicate
30 when Device C 306 of FIG. 3 can start to send data packets, at an offset time t_2 from the start of the D2D SCH Segment 210).

[0039] The boundary between the D2D RACH segment 208 and the D2D SCH segment 210 can be set explicitly or implicitly. Restated, the amount of

time for actual scheduled transmissions, versus contention for the scheduled transmission, can be fixed or adjusted. For explicit definition, this boundary can be defined by the eNodeB, another other network entity, or set according to pre-defined rules for D2D communications.

5 [0040] For implicit definition, the boundary can be adjusted by D2D devices in each frame (e.g., during each D2D RACH segment 208, or for multiple frames using one scheduling effective for N number of frames). The boundary may be adjusted based upon the successful channel reservations that are known to all devices. The last device that sends a request-to-send message can calculate if
10 the duration of the D2D RACH segment 208 plus the duration of the D2D SCH segment 210, including the outstanding request, might exceed the D2D Zone 206. If the answer is no (which means there is enough time remaining in the D2D Zone 206 to conduct the request and the data transmission), the transmitting device can send a request-to-send message. Thus, the boundary of
15 the D2D RACH segment 208 and the D2D SCH segment 210 can be set automatically after the reception of a clear-to-send message sent from the last device in the D2D RACH segment 208.

[0041] Before providing a request-to-send message or a response to the request-to-send (a clear-to-send message), the devices may perform a calculation
20 to ensure that the duration of all scheduled data transmissions will not exceed the D2D zone boundary. If the total transmission will exceed the D2D zone boundary, the transmission(s) may be split up, or the transmission(s) may be rescheduled to another D2D zone. D2D devices may know or may be informed of the size (duration) of available D2D zone resources (e.g., how many time slots
25 exist for usage with the D2D communications). Thus, D2D devices or UEs can decide scheduling of a shared channel by themselves using distributive techniques.

[0042] FIG. 5 illustrates a flowchart 500 for a device to schedule a D2D communication using a contention procedure according to some embodiments.
30 As shown in operation 502, a transmitting wireless communication device has data to send via a D2D communication. In decision 504, a determination is made whether the contention segment (e.g., window) for the D2D

communication is ongoing. If not, the data transmission may be delayed until the next contention segment for D2D communications (operation 510).

[0043] If as a result (of decision 504) the contention segment for the D2D communication is ongoing, a determination is made whether the wireless channel is free (decision 506). If the channel is not free, the data transmission is delayed for at least a backoff period (operation 508). If the channel is free, the device may proceed with transmitting a request for scheduled data resources (operation 512), and a specification of the size or other attributes of the data to send (operation 514). A determination is then made whether the transmitting wireless communication device receives a clear-to-send acknowledgement and a time to send within a period of time (decision 516). If no clear-to-send acknowledgment has been received within a period of time, then a determination is made whether the number of times that the request was transmitted exceeds a maximum number of attempts (decision 518). If the maximum number of attempts is not exceeded, then the contention process is repeated (decision 504); if the maximum number of attempts is exceeded, then the D2D communication is delayed until a next contention segment (operation 510). If, however, the clear-to-send acknowledgment and the time to send are successfully received, then the data transmission may occur during the designated time to send (operation 520).

[0044] FIG. 6A illustrates a flowchart 600 of an example method for controlling D2D channel access of a D2D data transmission, from a transmitting device with a series of time windows, according to a further described example. As depicted, in operation 602, a transmitting device sends a request message during a resource contention window of the D2D time-frequency zone. The transmission of the request message may be delayed based on a backoff counter, detection of use of the contention channel, randomized access times, waiting periods, or other collision avoidance mechanisms.

[0045] In operation 604, still during the resource contention window, the transmitting device receives a response to the request message originating from the receiving device. The response includes a designated communication time for use during a scheduled window of the D2D time-frequency zone.

[0046] In operation 606, during the scheduled window of the D2D time-frequency zone, the data will be transmitted at the designated communication time. Various scheduling and re-scheduling mechanisms may be employed within the D2D time-frequency zone (or in another D2D time-frequency zone) to re-transmit the data upon failure or interruption of the data transmission, or lack of acknowledgment. The data transmission is then processed by the receiving device upon the successful receipt.

[0047] FIG. 6B illustrates a flowchart 610 of an example method for controlling D2D channel access of a D2D data reception at a receiving device according to a further described example. As depicted, in operation 612, a receiving device receives a request message during a resource condition window of the D2D time-frequency zone. The receipt of the request message may indicate the size of requested data transmission and other communication parameters as necessary to arrange scheduling.

[0048] In operation 614, still during the resource contention window, the receiving device transmits a response to the request message for receipt by the transmitting device. The response includes a designated communication time for use during a scheduled window of the D2D time-frequency zone.

[0049] In operation 616, during the scheduled window of the D2D time-frequency zone, the data will be received from the transmitting device starting at the designated communication time. The data transmission may be further processed by the receiving device upon the successful receipt, and an acknowledgment may be sent in response to receipt of the data.

[0050] The techniques and configurations described herein may be extended to operate in other configurations. For example, the techniques may be used in connection with a peer-to-peer or point-to-point network which involves connections over a plurality of devices (e.g., connections involving multiple hops). The techniques may also be used in connection with a standardized protocol defining response messages formats, timing, and conditions. Thus, implementations of the presently described contention and scheduling techniques are not limited to implementations with a 3GPP standard, but may also extend to device-to-device, peer-to-peer, point-to-point, machine-to-machine, and

distributed networks in accordance with IEEE 802.11 standards, IEEE 802.16 standards, and the like.

[0051] Functionality for the present technique may be incorporated in components or modules in a computing system (including a mobile device), a wireless network adapter, a wireless transceiver control, circuitry for such systems and devices, and in hardware and software implementations. Further, various methods or techniques, or certain aspects or portions of the functionality described herein, may take the form of program code (i.e., instructions) embodied in tangible media, such as flash memory, CD/DVD-ROMs, hard drives, portable storage devices, or any other machine-readable storage medium wherein, when the program code is loaded into and executed by a machine, such as a computer, the machine becomes an apparatus for practicing the various techniques. In the case of program code execution on programmable computers, the computing device may include a processor, a storage medium readable by the processor (including volatile and non-volatile memory and/or storage elements), at least one input device, and at least one output device. One or more programs that may implement or utilize the various techniques described herein may use an application programming interface (API), reusable controls, and the like. Such programs may be implemented in a high level procedural or object oriented programming language to communicate with a computer system. However, the program(s) may be implemented in assembly or machine language, if desired. In any case, the language may be a compiled or interpreted language, and combined with hardware implementations.

[0052] FIG. 7 provides an example illustration of a mobile device 700, such as a UE, a mobile station (MS), a mobile wireless device, a mobile communication device, a tablet, a handset, or other type of mobile wireless device. The mobile device 700 may include one or more antennas 708 within housing 702 that are configured to communicate with a base station (BS), an eNodeB, or other type of wireless wide area network (WWAN) access point. The mobile device 700 may be configured to communicate using at least one wireless communication standard including 3GPP LTE, WiMAX, High Speed Packet Access (HSPA), Bluetooth (the term "Bluetooth" as used herein referring to a short-range digital communication protocol including a short-haul wireless

protocol frequency-hopping spread-spectrum (FHSS) communication technique operating in the 2.4 GHz spectrum), and Wi-Fi. The mobile device 700 may communicate using separate antennas for each wireless communication standard or shared antennas for multiple wireless communication standards. The mobile
5 device 700 may communicate in a wireless local area network (WLAN), a wireless personal area network (WPAN), and/or a WWAN.

[0053] FIG. 7 also provides an illustration of a microphone 720 and one or more speakers 712 that may be used for audio input and output from the mobile device 700. The display screen 704 may be a liquid crystal display (LCD)
10 screen, or other type of display screen such as an organic light emitting diode (OLED) display. The display screen 704 may be configured as a touch screen. The touch screen may use capacitive, resistive, or another type of touch screen technology. An application processor 714 and a graphics processor 718 may be coupled to internal memory 716 to provide processing and display capabilities.
15 A non-volatile memory port 710 may also be used to provide data input/output options to a user. The non-volatile memory port 710 may also be used to expand the memory capabilities of the mobile device 700. A keyboard 706 may be integrated with the mobile device 700 or wirelessly connected to the mobile device 700 to provide additional user input. A virtual keyboard may also be
20 provided using the touch screen.

[0054] FIG. 8 is a block diagram illustrating an example computer system machine upon which any one or more of the methodologies herein discussed may be run. Computer system 800 may be embodied as the computing device 104, mobile device 106, mobile device 700 (from FIGS. 1 and 7), or any other
25 computing platform described or referred to herein. In alternative embodiments, the machine operates as a standalone device or may be connected (e.g., networked) to other machines. In a networked deployment, the machine may operate in the capacity of either a server or a client machine in server-client network environments, or it may act as a peer machine in peer-to-peer (or
30 distributed) network environments. The machine may be a personal computer (PC) that may or may not be portable (e.g., a notebook or a netbook), a tablet, a set-top box (STB), a gaming console, a Personal Digital Assistant (PDA), a mobile telephone or smartphone, a web appliance, a network router, switch or

bridge, or any machine capable of executing instructions (sequential or otherwise) that specify actions to be taken by that machine. Further, while only a single machine is illustrated, the term “machine” shall also be taken to include any collection of machines that individually or jointly execute a set (or multiple sets) of instructions to perform any one or more of the methodologies discussed herein.

5 [0055] Example computer system 800 includes a processor 802 (e.g., a central processing unit (CPU), a graphics processing unit (GPU) or both), a main memory 804 and a static memory 806, which communicate with each other via
10 an interconnect 808 (e.g., a link, a bus, etc.). The computer system 800 may further include a video display unit 810, an alphanumeric input device 812 (e.g., a keyboard), and a user interface (UI) navigation device 814 (e.g., a mouse). In one embodiment, the video display unit 810, input device 812 and UI navigation device 814 are a touch screen display. The computer system 800 may
15 additionally include a storage device 816 (e.g., a drive unit), a signal generation device 818 (e.g., a speaker), an output controller 832, a power management controller 834, and a network interface device 820 (which may include or operably communicate with one or more antennas 830, transceivers, or other wireless communications hardware), and one or more sensors 828, such as a
20 Global Positioning System (GPS) sensor, compass, location sensor, accelerometer, or other sensor.

[0056] The storage device 816 includes a machine-readable medium 822 on which is stored one or more sets of data structures and instructions 824 (e.g., software) embodying or utilized by any one or more of the methodologies or
25 functions described herein. The instructions 824 may also reside, completely or at least partially, within the main memory 804, static memory 806, and/or within the processor 802 during execution thereof by the computer system 800, with the main memory 804, static memory 806, and the processor 802 also constituting machine-readable media.

30 [0057] While the machine-readable medium 822 is illustrated in an example embodiment to be a single medium, the term “machine-readable medium” may include a single medium or multiple media (e.g., a centralized or distributed database, and/or associated caches and servers) that store the one or more

instructions 824. The term “machine-readable medium” shall also be taken to include any tangible medium that is capable of storing, encoding, or carrying instructions for execution by the machine and that cause the machine to perform any one or more of the methodologies of the present disclosure or that is capable of storing, encoding or carrying data structures utilized by or associated with such instructions. The term “machine-readable medium” shall accordingly be taken to include, but not be limited to, solid-state memories, and optical and magnetic media. Specific examples of machine-readable media include non-volatile memory, including, by way of example, semiconductor memory devices (e.g., Electrically Programmable Read-Only Memory (EPROM), Electrically Erasable Programmable Read-Only Memory (EEPROM)) and flash memory devices; magnetic disks such as internal hard disks and removable disks; magneto-optical disks; and CD-ROM and DVD-ROM disks.

[0058] The instructions 824 may further be transmitted or received over a communications network 826 using a transmission medium via the network interface device 820 utilizing any one of a number of well-known transfer protocols (e.g., HTTP). Examples of communication networks include a LAN, WAN, the Internet, mobile telephone networks, Plain Old Telephone (POTS) networks, and wireless data networks (e.g., Wi-Fi, 3G, and 4G LTE/LTE-A or WiMAX networks). The term “transmission medium” shall be taken to include any intangible medium that is capable of storing, encoding, or carrying instructions for execution by the machine, and includes digital or analog communications signals or other intangible medium to facilitate communication of such software.

[0059] Other applicable network configurations may be included within the scope of the presently described communication networks. Although examples were provided with reference to a local area wireless network configuration and a wide area Internet network connection, it will be understood that communications may also be facilitated using any number of PANs, LANs, and WANs, using any combination of wired or wireless transmission mediums.

[0060] The embodiments described above may be implemented in one or a combination of hardware, firmware, and software. Embodiments may also be implemented as instructions stored on a computer-readable storage device,

which may be read and executed by at least one processor to perform the operations described herein. A computer-readable storage device may include any non-transitory mechanism for storing information in a form readable by a machine (e.g., a computer). For example, a computer-readable storage device
5 may include read-only memory (ROM), random-access memory (RAM), magnetic disk storage media, optical storage media, flash-memory devices, and other storage devices and media.

[0061] It should be understood that the functional units or capabilities described in this specification may have been referred to or labeled as
10 components or modules, in order to more particularly emphasize their implementation independence. For example, a component or module may be implemented as a hardware circuit comprising custom very-large-scale integration (VLSI) circuits or gate arrays, off-the-shelf semiconductors such as logic chips, transistors, or other discrete components. A component or module
15 may also be implemented in programmable hardware devices such as field programmable gate arrays, programmable array logic, programmable logic devices, or the like. Components or modules may also be implemented in software for execution by various types of processors. An identified component or module of executable code may, for instance, comprise one or more physical
20 or logical blocks of computer instructions, which may, for instance, be organized as an object, procedure, or function. Nevertheless, the executables of an identified component or module need not be physically located together, but may comprise disparate instructions stored in different locations which, when joined logically together, comprise the component or module and achieve the stated
25 purpose for the component or module.

[0062] Indeed, a component or module of executable code may be a single instruction, or many instructions, and may even be distributed over several different code segments, among different programs, and across several memory devices. Similarly, operational data may be identified and illustrated herein
30 within components or modules, and may be embodied in any suitable form and organized within any suitable type of data structure. The operational data may be collected as a single data set, or may be distributed over different locations including over different storage devices, and may exist, at least partially, merely

as electronic signals on a system or network. The components or modules may be passive or active, including agents operable to perform desired functions.

[0063] Additional examples of the presently described method, system, and device embodiments include the following, non-limiting configurations. Each of
5 the following non-limiting examples may stand on its own, or may be combined in any permutation or combination with any one or more of the other examples provided below or throughout the present disclosure.

[0064] Example 1 includes the subject matter embodied by a wireless communication device (e.g., a UE), comprising processing circuitry arranged to
10 communicate with an evolved Node B (eNodeB) using a 3GPP Long Term Evolution (LTE) or Long Term Evolution-Advanced (LTE-A) network connection and to facilitate device-to-device communications with a receiving UE using a direct network connection, by performing operations to: send a request message to a receiving UE, during a resource contention window, the
15 resource contention window allocated for scheduling device-to-device communications in a wireless channel using a contention channel access technique, the request message indicating a size for a data transmission; receive a response to the request message, from the receiving UE, the response confirming the request message and designating a transmission time for the data
20 transmission, and the designated transmission time occurring within a scheduled transmission window allocated for conducting the device-to-device communications; and perform the data transmission with the receiving UE, during the scheduled transmission window allocated for conducting the device-to-device communications, on the wireless channel at the designated
25 transmission time.

[0065] In Example 2, the subject matter of Example 1 can optionally include the processing circuitry being further arranged to perform operations to: maintain a low-power mode at the wireless communication device, beginning at
30 a start of the scheduled transmission window until the designated transmission time.

[0066] In Example 3, the subject matter of one or any combination of Examples 1-2 can optionally include the processing circuitry being further arranged to perform operations to: perform a contention channel access

technique to obtain access to the wireless channel during the resource contention window, the contention channel access technique including obtaining a backoff time for contention during the resource contention window, and waiting for the backoff time to expire, prior to sending the request message during the resource contention window.

5 [0067] In Example 4, the subject matter of one or any combination of Examples 1-3 can optionally include the processing circuitry being further arranged to perform operations to: resend the request message during the resource contention window in response to the request message not being
10 acknowledged by the receiving device within a period of time.

[0068] In Example 5, the subject matter of one or any combination of Examples 1-4 can optionally include the resource contention window and the scheduled transmission window being allocated in subframes for an uplink period defined in a carrier network.

15 [0069] In Example 6, the subject matter of one or any combination of Examples 1-5 can optionally include the uplink period being defined in the carrier network according to a standard provided from a 3GPP Long Term Evolution (LTE) or Long Term Evolution-Advanced (LTE-A) standards family.

[0070] In Example 7, the subject matter of one or any combination of
20 Examples 1-6 can optionally include the resource contention window and the scheduled transmission window being allocated for peer-to-peer communications among devices according to a standard from an IEEE 802.11 standards family, or for machine-to-machine communications among devices according to a standard from an IEEE 802.16 standards family.

25 [0071] In Example 8, the subject matter of one or any combination of Examples 1-7 can optionally include the resource contention window and the scheduled transmission window occurring in a zone allocated for the device-to-device communications in a wireless channel, wherein a size of the resource contention window relative to the scheduled transmission window is configured
30 to change based on characteristics of one or more data transmissions requested during the resource contention window.

[0072] Example 9 can include, or can optionally be combined with all or portions of the subject matter of one or any combination of Examples 1-8 to

include a method performed by a dual-mode user equipment (UE) for facilitating device-to-device communications with a receiving wireless communications device, the dual-mode UE configured for communications with a carrier-based network in addition to the device-to-device communications, and the method

5 comprising: accessing a wireless channel using a contention channel access technique, within a resource contention window allocated for scheduling device-to-device communications in a wireless channel, the resource contention window occurring during a device-to-device communications period indicated by a carrier-based network; transmitting a request message to the receiving

10 communications device, within the resource contention window, to obtain a designated transmission time for a device-to-device data transmission; and conducting the device-to-device data transmission from the transmitting communications device to the receiving communications device at the designated transmission time, within a scheduled transmission window allocated

15 for performing for the device-to-device communications in the wireless channel, the scheduled transmission window occurring during a device-to-device communications period indicated by the carrier-based network.

[0073] In Example 10, the subject matter of Example 9 can optionally include conducting a sleep mode within the scheduled transmission window; and

20 interrupting the sleep mode within the scheduled transmission window to conduct the device-to-device data transmission.

[0074] In Example 11, the subject matter of one or any combination of Examples 9-10 can optionally include the contention access technique including obtaining a backoff time for contention within the resource contention window,

25 and waiting for the backoff time to expire, prior to transmitting the request message within the resource contention window.

[0075] In Example 12, the subject matter of one or any combination of Examples 9-11 can optionally include the resource contention window and the scheduled transmission window being allocated in one or more subframes for a

30 scheduled uplink period defined for a carrier network, and wherein the scheduled uplink period is an uplink period established by a carrier network operating according to a standard provided from a 3GPP Long Term Evolution (LTE) or Long Term Evolution-Advanced (LTE-A) standards family.

[0076] Example 13 can include, or can optionally be combined with all or portions of the subject matter of one or any combination of Examples 1-12 to include User Equipment (UE) comprising: a transceiver comprising circuitry including physical layer circuitry and media-access control layer circuitry, the circuitry arranged to establish device to device channel access in a wireless communication medium, by performing operations to: receive a request message, from a transmitting device, to conduct a data transmission during a resource contention window, the resource contention window being allocated for wireless device-to-device communications, the request message indicating a size for a data transmission and being sent from the transmitting device on the wireless communication medium using a contention-based technique; send a response to the request message, the response confirming the request message and designating a time for the data transmission, the transmission time occurring within a scheduled transmission window allocated for the wireless device-to-device communications; and receive the data transmission from the transmitting device via the wireless communication medium at the designated time, during the scheduled transmission window allocated for the wireless device-to-device communications; wherein the resource contention window and the scheduled transmission window are allocated for the wireless device-to-device communications according to timing designated by a network controlled by an evolved Node B (eNodeB).

[0077] In Example 14, the subject matter of Example 13 can optionally include the circuitry being further arranged to perform operations to: maintain, from the transmitting device, a low-power mode beginning at a start of the scheduled transmission window until the designated time.

[0078] In Example 15, the subject matter of one or any combination of Examples 13-14 can optionally include the circuitry being further arranged to perform operations to: obtain a backoff time for contention during the resource contention window, and waiting for the backoff time to expire, prior to sending the response to the request message, wherein the response to the request message is sent during the resource contention window.

[0079] In Example 16, the subject matter of one or any combination of Examples 13-15 can optionally include the circuitry being further arranged to

perform operations to: provide an acknowledgement of data received from the transmitting device in response to the data transmission.

[0080] In Example 17, the subject matter of one or any combination of Examples 13-16 can optionally include the resource contention window and the
5 scheduled transmission window being allocated in time slots for a scheduled uplink period defined for a carrier network provided from the eNodeB.

[0081] In Example 18, the subject matter of one or any combination of Examples 13-17 can optionally include the scheduled uplink period being an
10 uplink period defined according to a standard provided from a 3GPP Long Term Evolution (LTE) or Long Term Evolution-Advanced (LTE-A) standards family.

[0082] Example 19 can include, or can optionally be combined with all or portions of the subject matter of one or any combination of Examples 1-18 to include a method for facilitating device to device communications with a transmitting device, comprising: processing a request message to conduct a data
15 transmission during a resource contention window and obtain a time of transmission for the data transmission, the request message indicating a size for the data transmission and being sent from the transmitting device over a wireless medium using a contention channel access technique to access the wireless medium; transmitting a response to the request message, the response confirming
20 the request message and designating a transmission time for the data transmission, the transmission time designated within a scheduled transmission window; and processing the data transmission from the transmitting device on the wireless channel received at a designated communication time during the scheduled transmission window; wherein the scheduled transmission window
25 and the resource contention window are designated by an evolved Node B (eNodeB) for performance of wireless device-to-device communications on the wireless medium.

[0083] In Example 20, the subject matter of Example 19 can optionally include conducting a sleep mode during the scheduled transmission window; and
30 interrupting the sleep mode during the scheduled transmission window to conduct the data transmission.

[0084] In Example 21, the subject matter of one or any combination of Examples 19-20 can optionally include the response to the request message

being transmitted via the wireless medium in connection with the contention channel access technique, wherein the contention channel access technique includes obtaining a backoff time for contention during the resource contention window, and waiting for the backoff time to expire, prior to transmitting the response to the request message during the resource contention window.

5 [0085] In Example 22, the subject matter of one or any combination of Examples 19-21 can optionally include the resource contention window and the scheduled transmission window being allocated for a scheduled uplink period defined for a network operating according to a standard provided from a 3GPP
10 Long Term Evolution (LTE) or Long Term Evolution-Advanced (LTE-A) standards family.

[0086] The Abstract is provided to allow the reader to ascertain the nature and gist of the technical disclosure. It is submitted with the understanding that it will not be used to limit or interpret the scope or meaning of the claims. The
15 following claims are hereby incorporated into the detailed description, with each claim standing on its own as a separate embodiment.

CLAIMS

What is claimed is:

1. A user equipment (UE), comprising processing circuitry arranged to
5 communicate with an evolved Node B (eNodeB) using a 3GPP Long Term
Evolution (LTE) or Long Term Evolution-Advanced (LTE-A) network
connection and to facilitate device-to-device communications with a receiving
UE using a direct network connection, by performing operations to:
 - send a request message to a receiving UE, during a resource contention
10 window, the resource contention window allocated for scheduling device-to-
device communications in a wireless channel using a contention channel access
technique, the request message indicating a size for a data transmission;
 - receive a response to the request message, from the receiving UE, the
response confirming the request message and designating a transmission time for
15 the data transmission, and the designated transmission time occurring within a
scheduled transmission window allocated for conducting the device-to-device
communications; and
 - perform the data transmission with the receiving UE, during the
scheduled transmission window allocated for conducting the device-to-device
20 communications, on the wireless channel at the designated transmission time.
2. The UE of claim 1, the processing circuitry further arranged to perform
operations to:
 - maintain a low-power mode at the wireless communication device,
beginning at a start of the scheduled transmission window until the designated
25 transmission time.
3. The UE of claim 1, the processing circuitry further arranged to perform
operations to:
 - perform a contention channel access technique to obtain access to the
wireless channel during the resource contention window, the contention channel
30 access technique including obtaining a backoff time for contention during the

resource contention window, and waiting for the backoff time to expire, prior to sending the request message during the resource contention window.

4. The UE of claim 1, the processing circuitry further arranged to perform operations to:

5 resend the request message during the resource contention window in response to the request message not being acknowledged by the receiving device within a period of time.

5. The UE of claim 1, wherein the resource contention window and the scheduled transmission window are allocated in subframes for an uplink period
10 defined in a carrier network.

6. The UE of claim 5, wherein the uplink period is defined in the carrier network according to a standard provided from a LTE or LTE-A standards family.

7. The UE of claim 1, wherein the resource contention window and the
15 scheduled transmission window are allocated for peer-to-peer communications among devices according to a standard from an IEEE 802.11 standards family, or for machine-to-machine communications among devices according to a standard from an IEEE 802.16 standards family.

8. The UE of claim 1, wherein the resource contention window and the
20 scheduled transmission window occur in a zone allocated for the device-to-device communications in a wireless channel, and wherein a size of the resource contention window relative to the scheduled transmission window is configured to change based on characteristics of one or more data transmissions requested during the resource contention window.

25 9. A method performed by a dual-mode user equipment (UE) for facilitating device-to-device communications with a receiving wireless communications device, the dual-mode UE configured for communications with a carrier-based

network in addition to the device-to-device communications, and the method comprising:

accessing a wireless channel using a contention channel access technique, within a resource contention window allocated for scheduling device-to-device communications in a wireless channel, the resource contention window
5 occurring during a device-to-device communications period indicated by a carrier-based network;

transmitting a request message to the receiving communications device, within the resource contention window, to obtain a designated transmission time
10 for a device-to-device data transmission; and

conducting the device-to-device data transmission from the transmitting communications device to the receiving communications device at the designated transmission time, within a scheduled transmission window allocated for performing for the device-to-device communications in the wireless channel,
15 the scheduled transmission window occurring during a device-to-device communications period indicated by the carrier-based network.

10. The method of claim 9, further comprising:

conducting a sleep mode within the scheduled transmission window; and
interrupting the sleep mode within the scheduled transmission window to
20 conduct the device-to-device data transmission.

11. The method of claim 9, wherein the contention access technique includes obtaining a backoff time for contention within the resource contention window, and waiting for the backoff time to expire, prior to transmitting the request message within the resource contention window.
25

12. The method of claim 9, wherein the resource contention window and the scheduled transmission window are allocated in one or more subframes for a scheduled uplink period defined for a carrier network, and wherein the scheduled uplink period is an uplink period established by a carrier network operating
30 according to a standard provided from a 3GPP Long Term Evolution (LTE) or Long Term Evolution-Advanced (LTE-A) standards family.

13. User Equipment (UE) comprising:
a transceiver comprising circuitry including physical layer circuitry and media-access control layer circuitry, the circuitry arranged to establish device to device channel access in a wireless communication medium, by performing
5 operations to:
receive a request message, from a transmitting device, to conduct a data transmission during a resource contention window, the resource contention window being allocated for wireless device-to-device communications, the request message indicating a size for a data transmission and being sent from the
10 transmitting device on the wireless communication medium using a contention-based technique;
send a response to the request message, the response confirming the request message and designating a time for the data transmission, the transmission time occurring within a scheduled transmission window allocated
15 for the wireless device-to-device communications; and
receive the data transmission from the transmitting device via the wireless communication medium at the designated time, during the scheduled transmission window allocated for the wireless device-to-device communications;
20 wherein the resource contention window and the scheduled transmission window are allocated for the wireless device-to-device communications according to timing designated by a network controlled by an evolved Node B (eNodeB).
14. The user equipment of claim 13, the circuitry further arranged to perform
25 operations to:
maintain, from the transmitting device, a low-power mode beginning at a start of the scheduled transmission window until the designated time.
15. The user equipment of claim 13, the circuitry further arranged to perform
operations to:
30 obtain a backoff time for contention during the resource contention window, and waiting for the backoff time to expire, prior to sending the response

to the request message, wherein the response to the request message is sent during the resource contention window.

16. The user equipment of claim 13, the circuitry further arranged to perform operations to:

- 5 provide an acknowledgement of data received from the transmitting device in response to the data transmission.

17. The user equipment of claim 13, wherein the resource contention window and the scheduled transmission window are allocated in time slots for a scheduled uplink period defined for a carrier network provided from the eNodeB.

18. The user equipment of claim 17, wherein the scheduled uplink period is an uplink period defined according to a standard provided from a 3GPP Long Term Evolution (LTE) or Long Term Evolution-Advanced (LTE-A) standards family.

19. A method for facilitating device-to-device communications with a transmitting device, comprising:

processing a request message to conduct a data transmission during a resource contention window and obtain a time of transmission for the data transmission, the request message indicating a size for the data transmission and being sent from the transmitting device over a wireless medium using a contention channel access technique to access the wireless medium;

20 transmitting a response to the request message, the response confirming the request message and designating a transmission time for the data transmission, the transmission time designated within a scheduled transmission window; and

25 processing the data transmission from the transmitting device on the wireless channel received at a designated communication time during the scheduled transmission window;

wherein the scheduled transmission window and the resource contention window are designated by an evolved Node B (eNodeB) for performance of wireless device-to-device communications on the wireless medium.

20. The method of claim 19, further comprising:
5 conducting a sleep mode during the scheduled transmission window; and
 interrupting the sleep mode during the scheduled transmission window to
conduct the data transmission.

21. The method of claim 19, wherein the response to the request message is
transmitted via the wireless medium in connection with the contention channel
10 access technique, wherein the contention channel access technique includes
obtaining a backoff time for contention during the resource contention window,
and waiting for the backoff time to expire, prior to transmitting the response to
the request message during the resource contention window.

22. The method of claim 19, wherein the resource contention window and
15 the scheduled transmission window are allocated for a scheduled uplink period
defined for a network operating according to a standard provided from a 3GPP
Long Term Evolution (LTE) or Long Term Evolution-Advanced (LTE-A)
standards family.

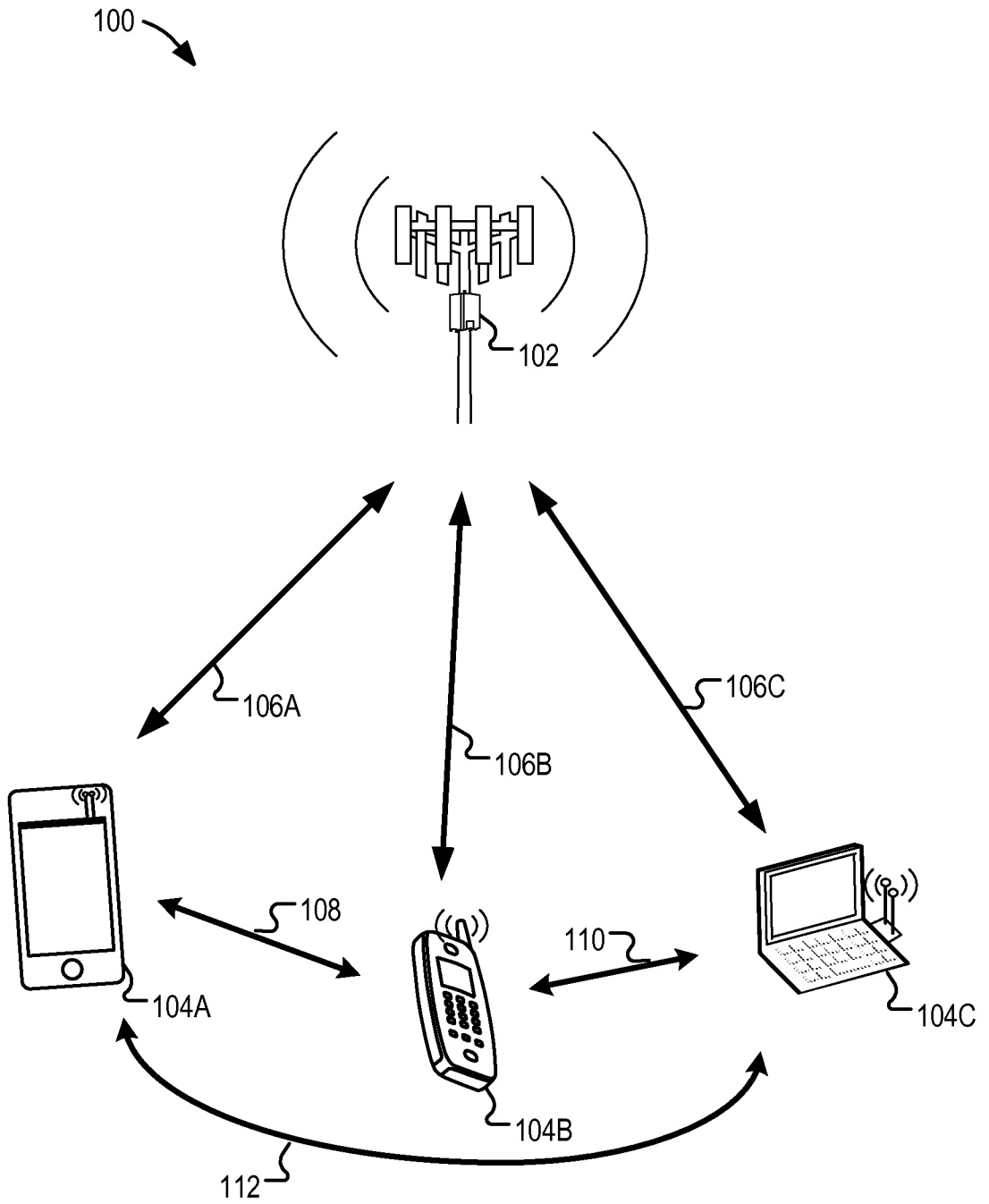

FIG. 1

2/7

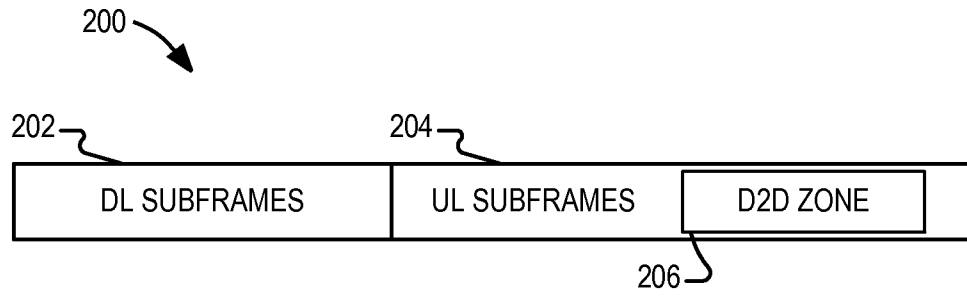

FIG. 2A

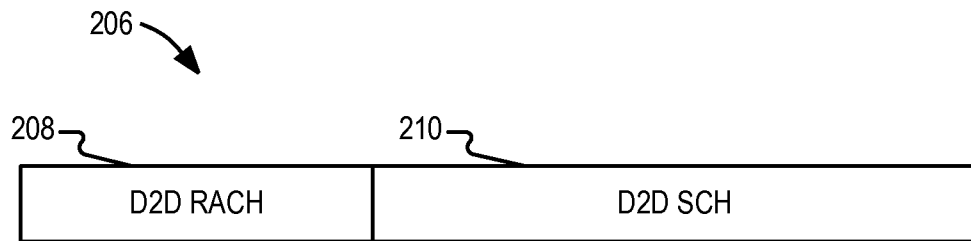

FIG. 2B

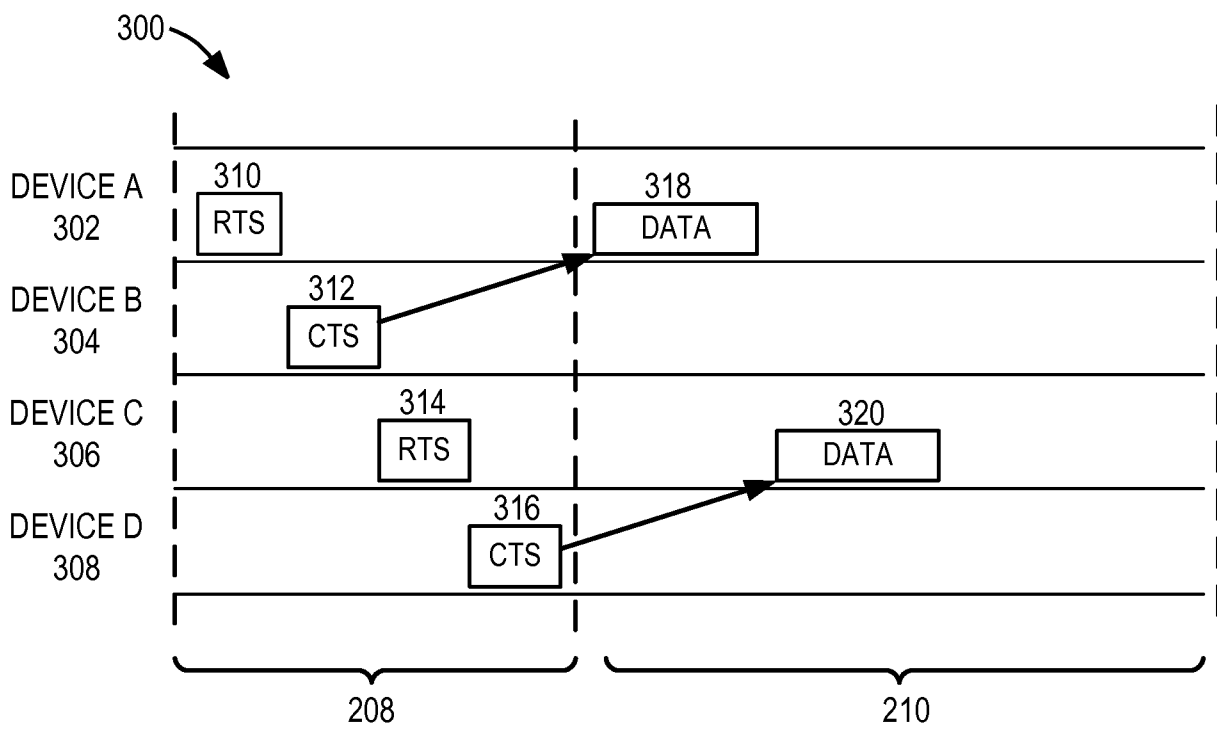

FIG. 3

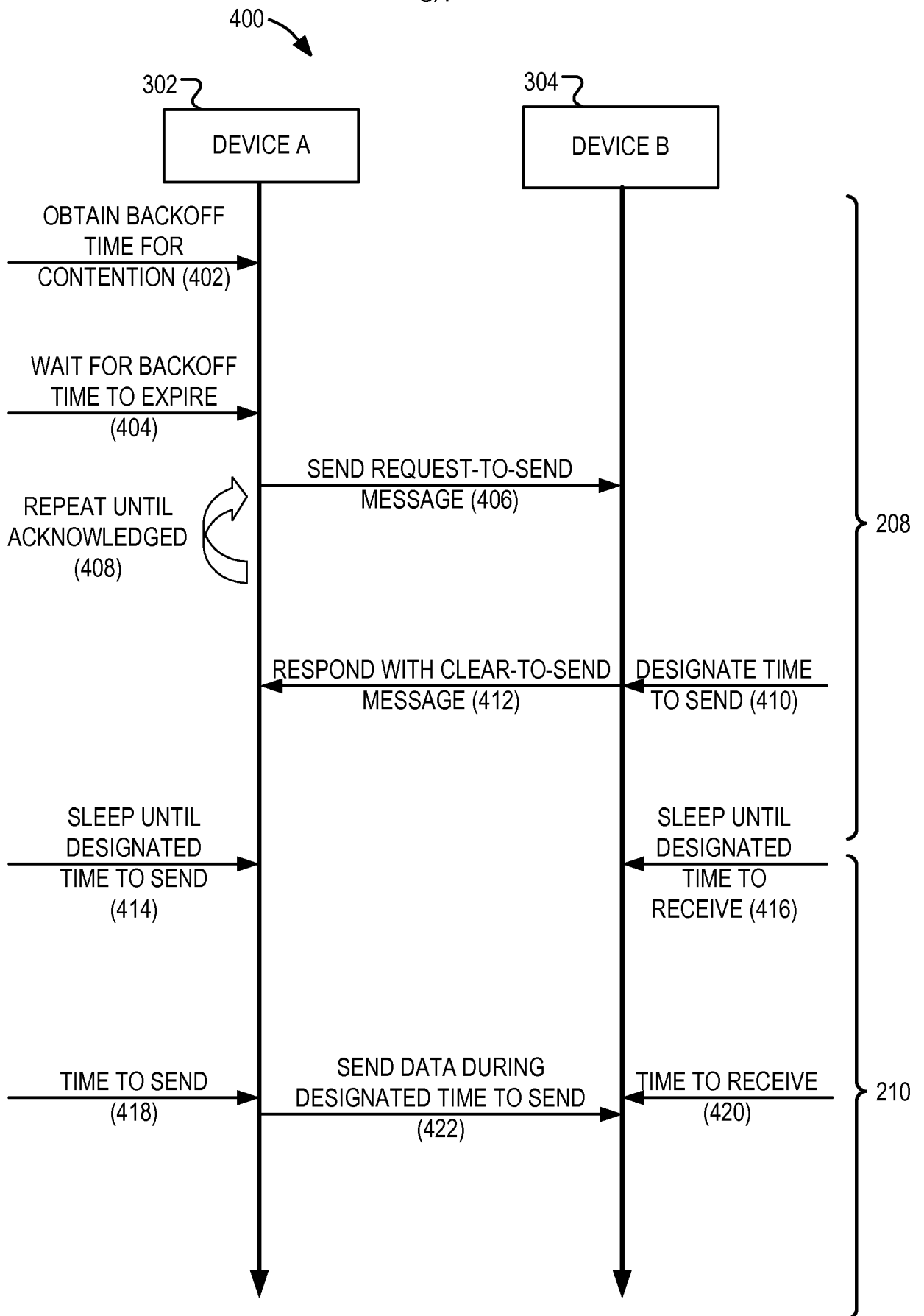

FIG. 4

4/7

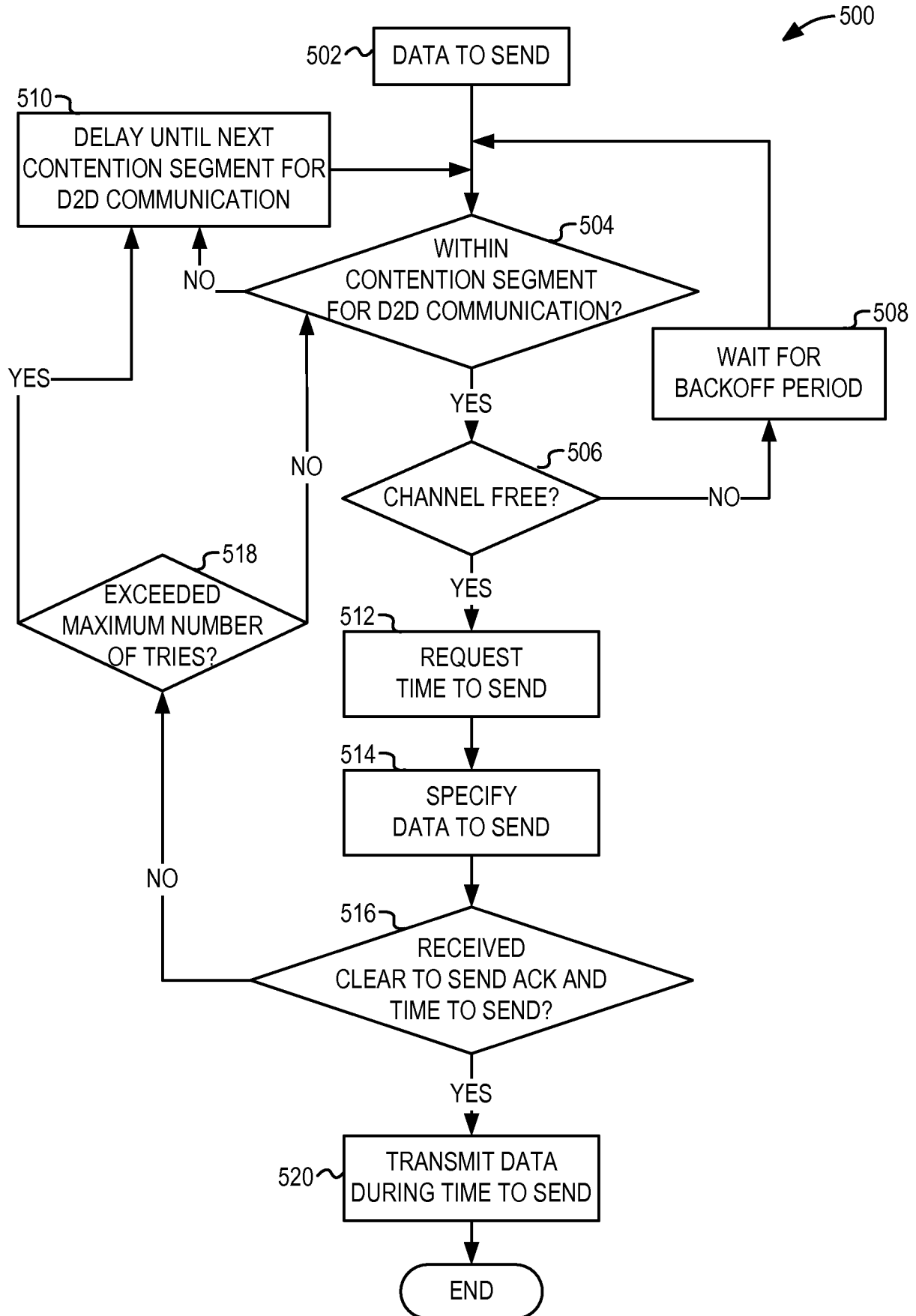

FIG. 5

5/7

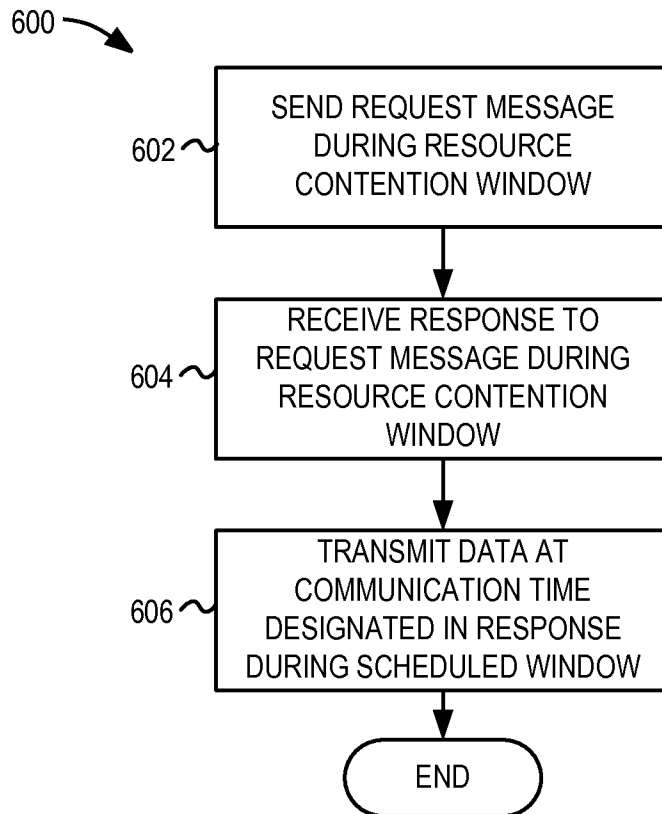

FIG. 6A

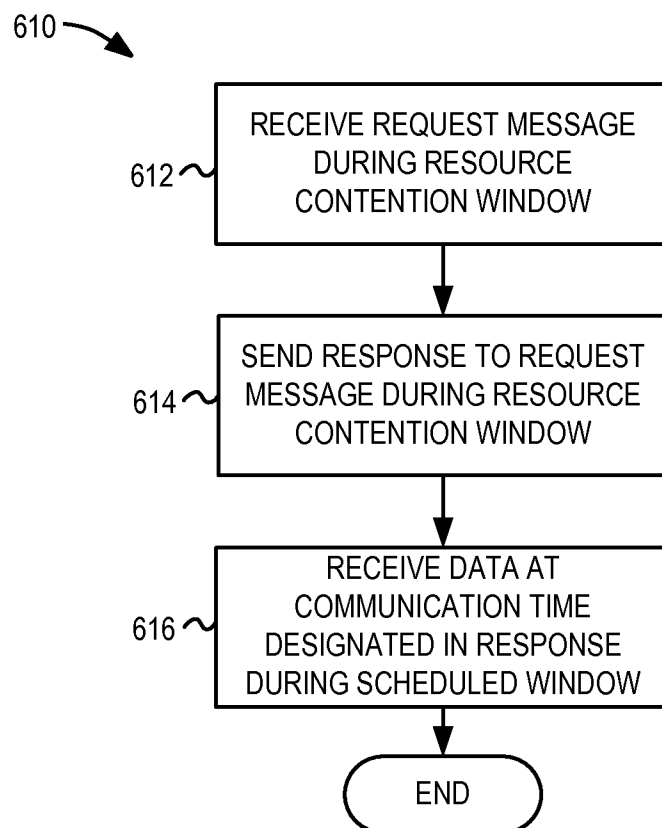

FIG. 6B

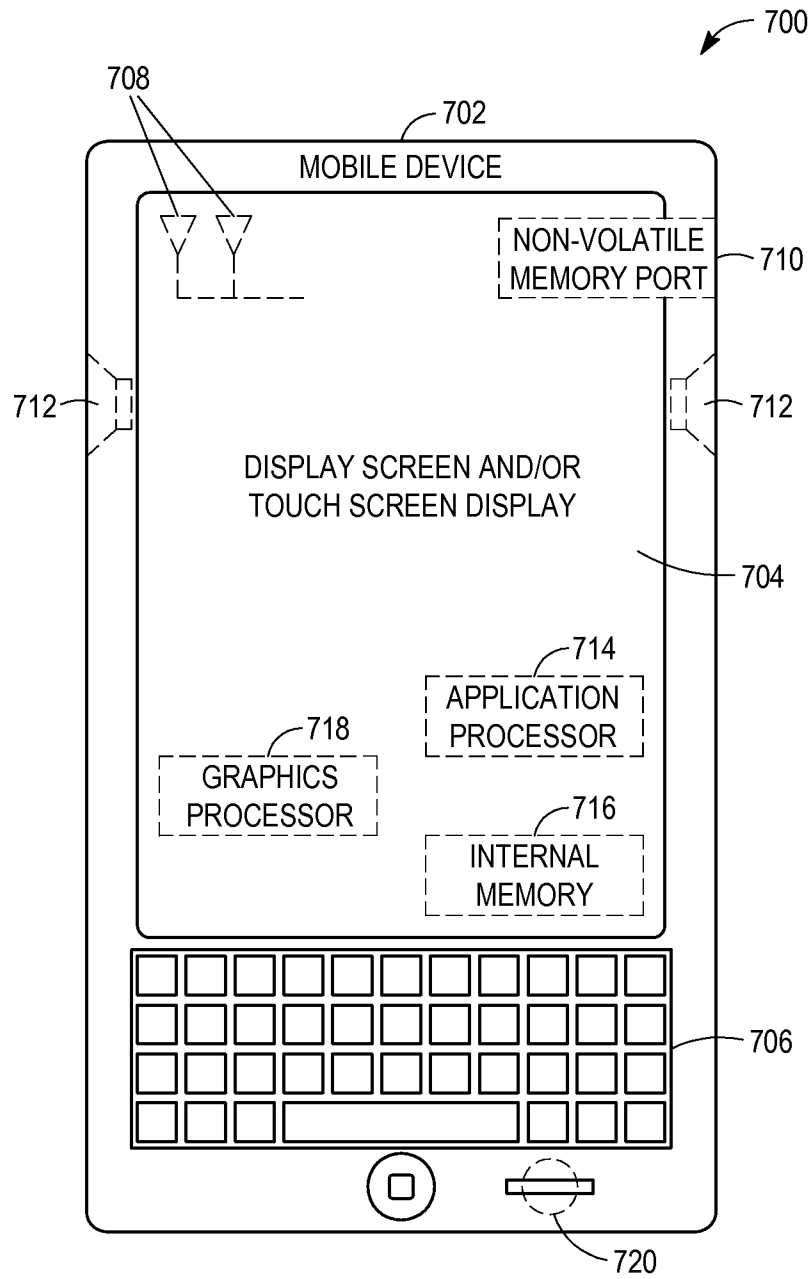

FIG. 7

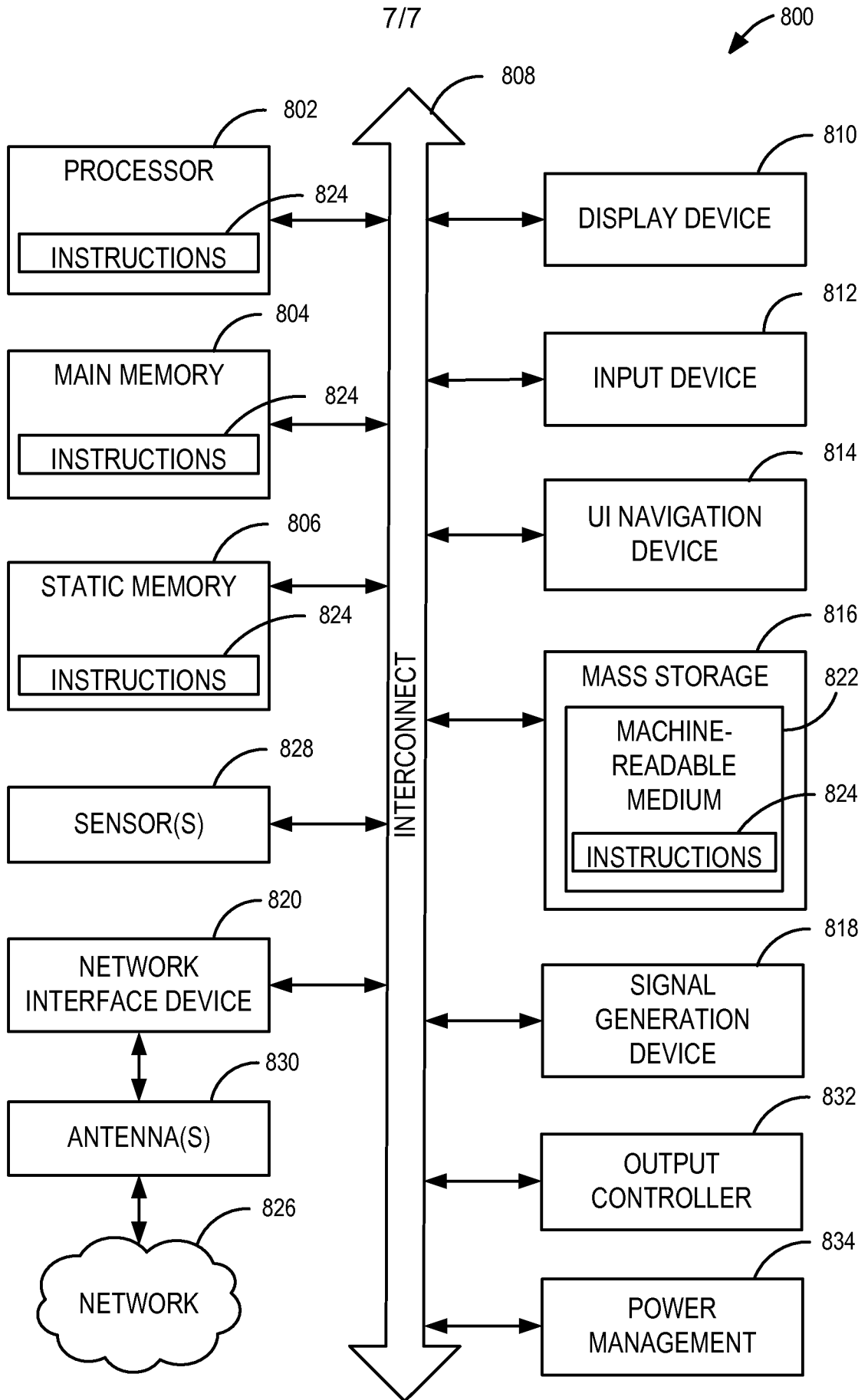

FIG. 8

A. CLASSIFICATION OF SUBJECT MATTER**H04W 74/08(2009.01)i**

According to International Patent Classification (IPC) or to both national classification and IPC

B. FIELDS SEARCHEDMinimum documentation searched (classification system followed by classification symbols)
H04W 74/08; H04B 7/26; G06F 15/173; H04J 11/00; H04W 68/02; H04W 52/02; H04W 72/04Documentation searched other than minimum documentation to the extent that such documents are included in the fields searched
Korean utility models and applications for utility models
Japanese utility models and applications for utility modelsElectronic data base consulted during the international search (name of data base and, where practicable, search terms used)
eKOMPASS(KIPO internal) & Keywords: D2D, scheduling, window, contention, request, LTE, and similar terms.**C. DOCUMENTS CONSIDERED TO BE RELEVANT**

Category*	Citation of document, with indication, where appropriate, of the relevant passages	Relevant to claim No.
Y	US 2012-0030358 A1 (JAMES A. MACKENZIE) 2 February 2012 See paragraphs [0030]-[0032], [0087]-[0097], [0106]-[0109], [0114].	1-7, 9-22
A		8
Y	WO 2012-087009 A2 (LG ELECTRONICS INC.) 28 June 2012 See paragraphs [0003]-[0007], [0012], [0015], [0057], [0061], [0065]-[0067].	1-7, 9-22
A	US 2011-0306349 A1 (SAMI-JUKKA HAKOLA et al.) 15 December 2011 See abstract; paragraphs [0013], [0014], [0019]-[0023], [0036]-[0038], [0055], [0056].	1-22
A	WO 2012-077977 A2 (LG ELECTRONICS INC.) 14 June 2012 See paragraphs [7]-[11], [28], [35], [53], [60]-[63].	1-22
A	WO 2011-139043 A2 (LG ELECTRONICS INC.) 10 November 2011 See paragraphs [2]-[5], [32], [51], [58], [74].	1-22

 Further documents are listed in the continuation of Box C. See patent family annex.

* Special categories of cited documents:

"A" document defining the general state of the art which is not considered to be of particular relevance

"E" earlier application or patent but published on or after the international filing date

"L" document which may throw doubts on priority claim(s) or which is cited to establish the publication date of citation or other special reason (as specified)

"O" document referring to an oral disclosure, use, exhibition or other means

"P" document published prior to the international filing date but later than the priority date claimed

"T" later document published after the international filing date or priority date and not in conflict with the application but cited to understand the principle or theory underlying the invention

"X" document of particular relevance; the claimed invention cannot be considered novel or cannot be considered to involve an inventive step when the document is taken alone

"Y" document of particular relevance; the claimed invention cannot be considered to involve an inventive step when the document is combined with one or more other such documents, such combination being obvious to a person skilled in the art

"&" document member of the same patent family

Date of the actual completion of the international search

26 August 2013 (26.08.2013)

Date of mailing of the international search report

27 August 2013 (27.08.2013)

Name and mailing address of the ISA/KR



Korean Intellectual Property Office
189 Cheongsa-ro, Seo-gu, Daejeon Metropolitan City,
302-701, Republic of Korea

Facsimile No. +82-42-472-7140

Authorized officer

KIM Byoung Sung

Telephone No. +82-42-481-8403



INTERNATIONAL SEARCH REPORT

Information on patent family members

International application No.

PCT/US2013/044543

Patent document cited in search report	Publication date	Patent family member(s)	Publication date
US 2012-0030358 A1	02/02/2012	None	
WO 2012-087009 A2	28/06/2012	WO 2012-087009 A3	04/10/2012
US 2011-0306349 A1	15/12/2011	CN 102939788 A EP 2583526 A1 US 8359038 B2 WO 2011-157884 A1	20/02/2013 24/04/2013 22/01/2013 22/12/2011
WO 2012-077977 A2	14/06/2012	CN 102572777 A JP 2012-124897 A KR 10-2012-0063426 A US 2012-0142371 A1 WO 2012-077977 A3 WO 2013-009107 A2 WO 2013-009107 A3	11/07/2012 28/06/2012 15/06/2012 07/06/2012 11/10/2012 17/01/2013 11/04/2013
WO 2011-139043 A2	10/11/2011	CA 2736735 A1 CN 102656916 A CN 102783204 A CN 102870486 A CN 102884830 A EP 2529572 A2 EP 2529573 A2 EP 2559286 A2 EP 2566277 A2 GB 2479468 A GB 2488927 A KR 10-2011-0088446 A KR 10-2012-0083464 A KR 10-2013-0016315 A KR 10-2013-0029066 A KR 10-2013-0043087 A US 2011-0183662 A1 US 2012-0322386 A1 US 2013-0034013 A1 US 2013-0034059 A1 US 2013-0058301 A1 US 8467781 B2 WO 2011-093665 A2 WO 2011-093665 A3 WO 2011-093666 A2 WO 2011-093666 A3 WO 2011-129555 A2 WO 2011-129555 A3 WO 2011-136552 A2 WO 2011-136552 A3 WO 2011-136557 A2 WO 2011-136557 A3	11/10/2011 05/09/2012 14/11/2012 09/01/2013 16/01/2013 05/12/2012 05/12/2012 20/02/2013 06/03/2013 12/10/2011 12/09/2012 03/08/2011 25/07/2012 14/02/2013 21/03/2013 29/04/2013 28/07/2011 20/12/2012 07/02/2013 07/02/2013 07/03/2013 18/06/2013 04/08/2011 15/12/2011 04/08/2011 01/12/2011 20/10/2011 19/01/2012 03/11/2011 01/03/2012 03/11/2011 01/03/2012

INTERNATIONAL SEARCH REPORT

Information on patent family members

International application No.

PCT/US2013/044543

Patent document cited in search report	Publication date	Patent family member(s)	Publication date
		WO 2011-136558 A2	03/11/2011
		WO 2011-136558 A3	01/03/2012
		WO 2011-139043 A3	01/03/2012