

No. 648,986.

J. NORTHROP.
LOOM.

Patented May 8, 1900.

(Application filed Oct. 23, 1899.)

(No Model.)

3 Sheets—Sheet 1.

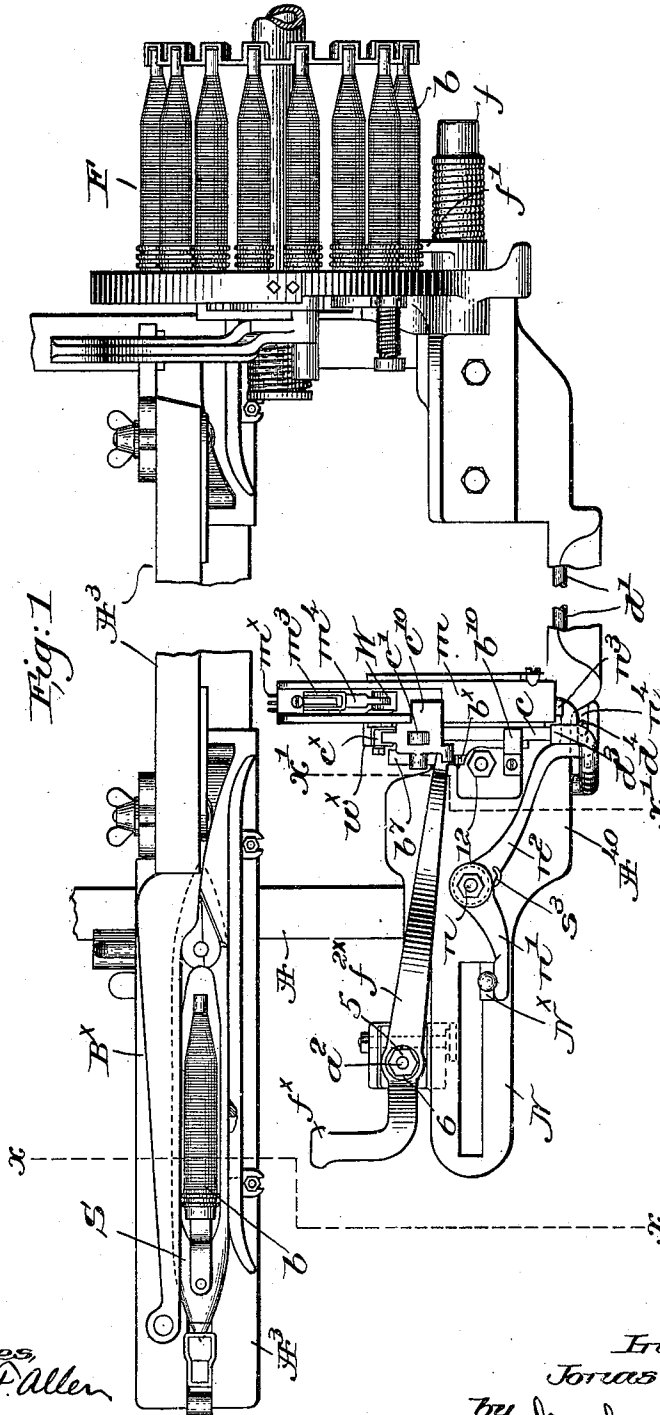

Witnesses,
Edward F. Allen
Thomas Drummond.

Inventor:
J. Northrop,
by Lewis Gregory,
attys.

No. 648,986.

J. NORTHROP.

Patented May 8, 1900.

LOOM.

(Application filed Oct. 23, 1899.)

(No Model.)

3 Sheets—Sheet 2.

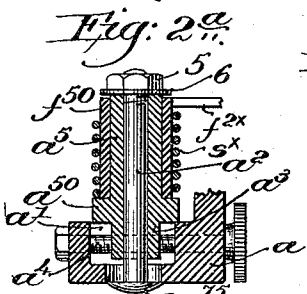
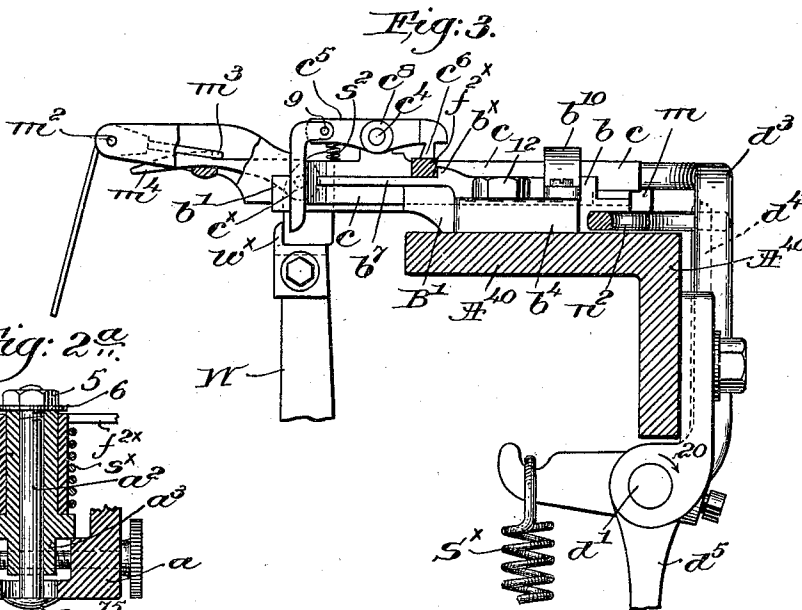
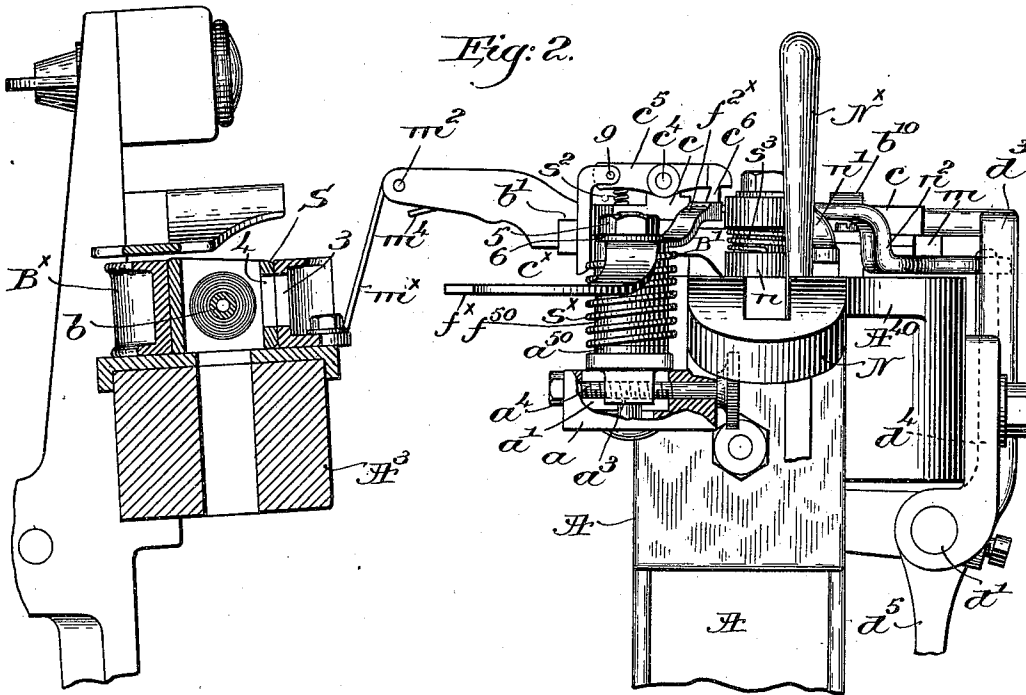

Witnesses,
 Frank G. Hattie.
 Edward D. Allen.

In witness whereof,
 I, Jonas Northrop,
 by Leasby Gregory,
 atty's,

No. 648,986.

J. NORTHROP.
LOOM.

Patented May 8, 1900.

(Application filed Oct. 23, 1899.)

(No Model.)

3 Sheets—Sheet 3.

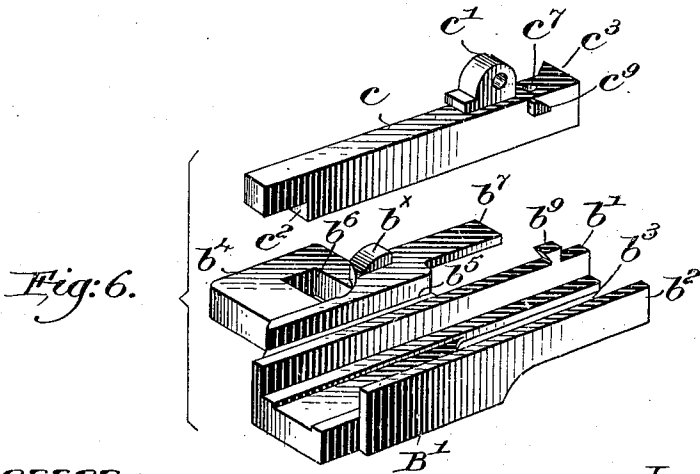
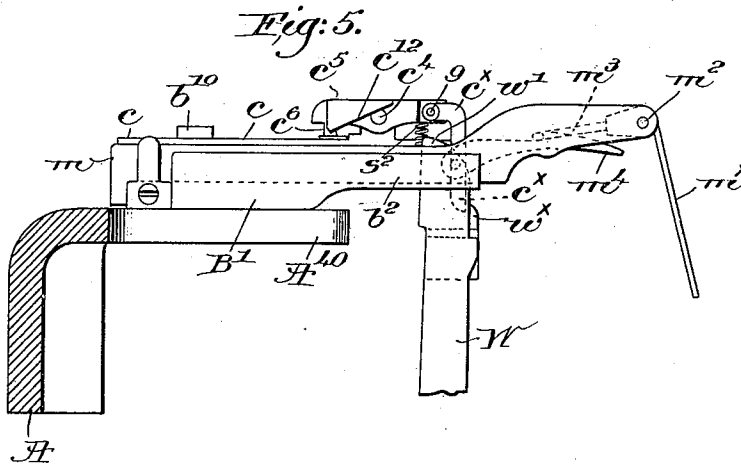
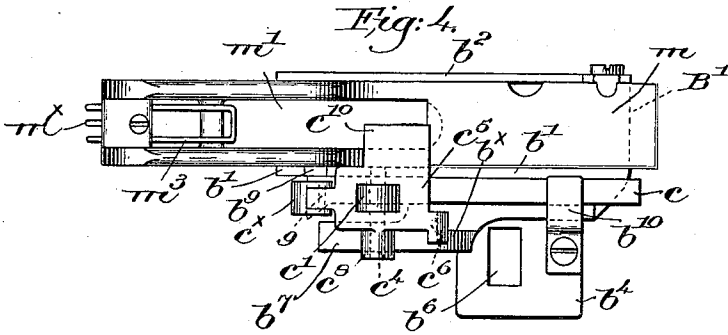

Witnesses,
Frank G. Hattin,
Edward G. Allen.

Inventor,
J. Northrop,
by Charles Gregory,
att'y.

UNITED STATES PATENT OFFICE.

JONAS NORTHROP, OF HOPEDALE, MASSACHUSETTS, ASSIGNOR TO THE DRAPER COMPANY, OF SAME PLACE AND PORTLAND, MAINE.

LOOM.

SPECIFICATION forming part of Letters Patent No. 648,986, dated May 8, 1900.

Application filed October 23, 1899. Serial No. 734,461. (No model.)

To all whom it may concern:

Be it known that I, JONAS NORTHROP, of Hopedale, county of Worcester, State of Massachusetts, have invented an Improvement in Looms, of which the following description, in connection with the accompanying drawings, is a specification, like letters and numerals on the drawings representing like parts.

This invention relates to looms provided with automatic filling supplying or changing mechanism wherein under certain conditions a fresh supply of filling is automatically effected, such a loom forming the subject-matter of United States Patent No. 529,940, dated November 27, 1894. It has been found desirable in such looms to make provision for effecting such filling change or transfer prior to the complete exhaustion of the filling in the shuttle, the filling-supplying mechanism being controlled as to its operation by a feeler which coöperates with the filling in the shuttle, the feeler performing the desired function when the filling has been exhausted to a predetermined extent. Various feeler mechanisms have been devised, among others that shown in United States Patents Nos. 600,016 and 626,187, the feeler, located at one side of the loom, encountering the filling in the shuttle each time the latter entered the adjacent shuttle-box, the movement of the lay being made effective through engagement of an actuator with the shuttle-wall to attain the operation of the means controlling the filling-supplying mechanism when the feeler had detected the predetermined exhaustion of the filling. It has been found in practice that the direct operation of the controlling means by the feeler introduces a variable and objectionable factor in the operation of the apparatus, objectionable because of its non-uniformity in action and also because the parts are subjected at times to undue strain. Again, in either of the feeler patents referred to it will be manifest that the relative movement of certain parts must be very slight, so that the "setting" or adjustment must be had between narrow limits, and if this slight movement be overstepped accidentally, due to rapid operation, the filling transfer is effected too soon. In my present invention the evil effects of direct action have been entirely

eliminated, the feeler itself playing no direct part in the actuation of the controlling means for the filling-supplying mechanism. The feeler is arranged to engage the filling in the shuttle as the lay beats up, and filling-induced movement of the feeler—*i. e.*, due to such engagement—is completed when the lay is fully forward. So long as there is a proper quantity of filling in the shuttle no change of operation of the filling-supplying mechanism takes place; but when the filling has been exhausted to a predetermined extent the feeler will have a very slight filling-induced movement or none at all, permitting the engagement of a member of the controlling means with a vibrating part of the loom, preferably the weft-hammer, which has a comparatively slow movement. Such engagement of the member of the controlling means and the actuator therefor operates to effect a change of filling, as will more readily appear hereinafter, and manifestly without the objectionable features due to the direct action of a rapidly-moving part. The construction hereinafter to be described also permits of very fine setting, so that the amount of filling-waste is reduced to a minimum.

The relation between the actuator and the coöperating member of the controlling means is unchanged in my present invention from the time the maximum amount of filling is in the shuttle up to the point of exhaustion, whereat change of filling is to take place, although it will be manifest that the filling-induced movement of the feeler will vary as the volume of filling changes.

In order to absolutely obviate a premature transfer of filling and consequent waste thereof, it is necessary after the feeling movement to prevent such rapid return of the feeler to normal position as would permit the engagement of the actuator with the coöperating member of the controlling means, or, in other words, to retard the return of the feeler until the actuator has passed the critical point in its stroke. If no such provision be made, it is possible, with the rapid movement of the lay and the relatively-slow motion of the actuator, for the feeler to at any time return to normal position before the actuator has passed such critical point, permitting the coöperating

member of the controlling means to be engaged by the actuator to thus effect filling change. As will fully appear hereinafter, I have so arranged and constructed the mechanism that the said member of the controlling means will prevent return of the feeler to normal position after each filling-induced or feeling movement until the actuator has passed the critical point in its stroke.

The usual weft or filling fork is herein utilized to stop the loom upon breakage of the filling or its accidental exhaustion.

Figure 1 is a top or plan view, centrally broken out, of a portion of a loom, including the lay and breast beam and filling-supplying mechanism, with one embodiment of my present invention shown in connection therewith. Fig. 2 is an enlarged transverse sectional view of the loom, taken on the line xx , Fig. 1, looking toward the right, the filling-supplying mechanism at the far side of the loom being omitted. Fig. 2^a is a detail in section, to be described, of the feeler-support. Fig. 3 is a similar view, also enlarged, on the line $x'x'$, Fig. 1, showing the parts in normal position before the feeler has felt the filling in the shuttle. Fig. 4 is an enlarged top or plan view of the weft or filling fork, its slide, and the latch-like member, with its support, forming part of the means for controlling the operation of the filling-supplying mechanism. Fig. 5 is an opposite side view of the parts shown in Fig. 3; and Fig. 6 is a perspective detail, enlarged, of the sliding latch-support and the guide therefor to be described.

The loom-frame A, breast-beam A⁴⁰, lay A³, the filling-feeder F, Fig. 1, comprising, essentially, connected rotatable plates suitably shaped to receive the ends of the filling-carriers b , the transferrer f' , mounted upon the stud f , and the operating or controlling shaft d' , adapted to be rotated in the direction of the arrow 20, Fig. 3, to effect a change of filling, and normally held in the position shown in said figure by the spring S^x, are and may be substantially all as represented in said Patent No. 529,940, wherein like letters and numerals are used to designate like parts, the parts hereinbefore referred to being operated substantially as provided for in said patent.

I have shown in Fig. 1 the filling-feeder F as located at one side of the loom and adapted to transfer a fresh supply of filling to the shuttle when in the adjacent shuttle-box, while the feeler mechanism is located at the other side of the loom, the feeler coöperating with the filling in the shuttle when the latter is in the box B^x. The usual notched holding-plate N for the shipper-lever N^x has secured to it a stand a , slotted at right angles to the breast-beam, as at a' , Figs. 2 and 2^a, and forming a support for an upright sleeve a^{50} , which rests and is adapted to be moved upon the top of the stand, an ear a^3 depending from the stud into the slot a' , having an offset threaded hole therein to be entered and engaged by a rotatable and non-longitudi-

nally-movable adjusting-screw a^4 . A headed stud a^3 is passed up through the bottom of the slot a' and the sleeve, the head a^{75} resting against the bottom of the stand, while a nut 5 and washer 6 on the upper end of the stud bear against the top of the sleeve and serve to clamp the latter in adjusted position on the stand a . Upon the reduced part a^5 of the sleeve, Fig. 2^a, I have mounted with a loose fit the hub f^{50} of the feeler, shown as a substantially L-shaped arm f^x , the nut and washer on the stud retaining the feeler in place while permitting it to rock freely. The sleeve forms a long bearing for the feeler, adding greatly to the steadiness of movement of the feeler and increasing the strength and durability of the parts. By means of the adjusting-screw the sleeve may be moved toward or away from the breast-beam, to thereby set or adjust the feeler according to the stroke of the lay or the size of shuttle which may be used. The opposite or inner end of the feeler is extended to form an arm f^{2x} , the free end of which is normally held against an abutment or stop b^x , located on a stand, to be described, secured to the breast-beam, a suitable spring s^x , surrounding the sleeve a^{50} , normally maintaining the feeler in the position shown in Figs. 1, 2, and 3.

The extremity of the feeler f^x is preferably extended laterally, as shown clearly in Fig. 1, and the feeler is adapted to pass through an aperture 3 in the front wall of the shuttle-box B^x, as the lay beats up.

The shuttle is provided with a slot 4 in its side wall, (see Fig. 2,) and when the shuttle is positioned in the box, as in Fig. 1, the feeler will pass through the slots 3 and 4 and will bear upon the mass of filling on the filling carrier or bobbin b until exhaustion of such filling to a predetermined point. The engagement of the feeler and the filling will up to a certain point take place before the lay completes its forward movement, and such engagement will tend to swing the feeler and the arm f^{2x} in opposite directions upon their fulcrum, and this filling-induced movement of the feeler will take place at each alternate beat of the lay until the filling has been so far exhausted that the feeler will be moved a very slight distance or not at all.

The stop b^x is secured to a stand or bracket B' (shown separately in Fig. 6) and secured to the breast-beam, the stand being provided with upright walls $b' b^3$ to form a guideway for the usual filling-fork slide m , the bottom of the guideway being longitudinally slotted, as at b^3 , to permit the vibration of the usual weft-hammer W, which is arranged, as is common, to operate at alternate beats of the lay. A lateral extension b^4 on the bracket is separated therefrom by a guideway b^5 , in which is longitudinally movable a sliding support or bar c , (shown separately in Fig. 6,) having an upturned ear c' thereon and cut away at the under side of its outer end, as at c^2 , the inner end of the slide being preferably en-

larged laterally. The stand B' is secured to the breast-beam, as herein shown, by a bolt 12, extended through a slot b^6 in the lateral extension b^4 of the said stand. The slide-bar c has fulcrumed upon its ear c' , as at c^4 , a latch-carrier c^5 , shown as a lever extended beyond the front and rear of its fulcrum, and at its outer end provided with a depending foot c^6 to rest upon the feeler-arm f^{2x} , when the latter is in its normal position against the stop b^x , said arm being supported by and sliding upon a shelf b^7 , forming a part of the stand B'. A spring s^2 , seated in a socket c^7 in the slide-bar, (see Fig. 6,) bears upon the under side of the latch-carrier at its inner end, the action of the spring being to lift said inner end, such movement of the latch-carrier being prevented so long as the feeler-arm f^{2x} is in normal position.

To the inner end of the latch-carrier is pivoted at 9 a depending latch c^x , which rests against the enlarged end c^3 of the slide-bar or support, the lower end of the latch when in its normal position (shown in Fig. 3) extending into the path of a dog or projection w^x of the weft-hammer W, so that when the weft-hammer moves to the right or toward the front of the loom (viewing Fig. 3) it will at the critical point of its stroke engage the latch and move it and the slide-bar c bodily to the right, the outer end of the said bar at such time engaging an upturned arm d^3 , fast on the rock-shaft d' , rocking the latter in the direction of the arrow 20, to thereby effect the operation of the filling-supplying mechanism, as in the patents hereinbefore referred to.

The latch-carrier is of a somewhat-peculiar shape in plan, (see Fig. 4,) the foot c^6 being shown as offset from one corner thereof, and the ear c' of the slide-bar extends up through a slot made in the latch-carrier, which latter is provided with a hub c^8 to receive the fulcrum-stud c^4 , providing thereby firm and good-sized bearings for the parts.

In order to prevent any lifting tendency of the slide-bar, it is provided on its side, near its inner end, with a lateral lug c^9 , having a beveled upper face to extend under an upturned and overhanging projection b^9 on the wall b' , and the extension b^4 has, as herein shown, an overlapping detent b^{10} secured to it and extended over the outer end of the slide-bar c , so that the latter when moved outwardly by engagement of the weft-hammer and the latch will move properly in its guideway b^5 . The return of the slide-bar to normal position is effected by the action of the spring S^x through the shaft d' and arm d^3 , inward movement of the slide being limited by the engagement of the lug c^9 and projection or stop b^9 , hereinbefore described.

When the filling in the shuttle is sufficient in volume to swing the feeler upon its fulcrum, the extremity of the feeler-arm f^{2x} will be swung inward or toward the lay, and thereby drawn from beneath the foot c^6 of the latch-carrier, whereupon the spring s^2 will lift the

inner end of the carrier, raising the latch from the path of engagement of the dog w^x of the weft-hammer before the critical point in the stroke of the latter is reached, and no movement of the slide c will be effected. When the latch is lifted, the foot c^6 descends between the stop b^x and the arm f^{2x} , and so prevents return of said arm against the stop, and consequently the return of the feeler to normal position is prevented until the foot c^6 is lifted or withdrawn from in front of the arm f^{2x} . Such withdrawal of the foot is effected when the latch-carrier is returned to normal position or reset, and to effect this operation I have herein provided the latch-carrier with a downwardly-inclined cam-surface c^{12} (see Fig. 5) on the under side of the laterally-extended portion c^{10} of the latch-carrier, such cam being in the path of and engaged by the upper extremity w' of the weft-hammer as the latter moves forward or toward the breast-beam after it has passed the critical point—that is, beyond the latch—it being understood that when withdrawal of the latch into inoperative position takes place it occurs before the weft-hammer reaches it on its outward stroke; but the latch-carrier and latch will be reset afterward on the same stroke of the weft-hammer, and the arm f^{2x} will engage the stop b^x prior to the next feeling movement of the feeler. On the return stroke of the weft-hammer the dog w^x passes under and tilts the latch.

It will be manifest that no matter how rapidly the loom is running the movement of the feeler itself has no direct action upon any of the parts of the means for controlling the filling-supplying mechanism, but that, on the contrary, a comparatively slowly-moving member of the loom is made the actuator for the controlling means, such means including the latch and its sliding support, the arm d^3 , and rock-shaft d' , and from the foregoing it will also be manifest that the feeler is not permitted to return to normal position until there is no possibility of the controlling means being actuated at that time. Any effects due to the momentum of the lay are entirely eliminated, and the feeling mechanism, which must necessarily be to a certain extent delicate in its construction, is relieved from all sudden shocks and strains due to such momentum action. When the weft-hammer engages the latch and moves the slide-bar toward the front of the loom, the latch travels in the space between the narrow shelf b^7 and the upright wall b' of the stand B', and after such action the spring S^x operates through the rock-shaft d' and arm d^3 to move the slide-bar back to its normal position, the next outward stroke of the weft-hammer operating to lift the foot c^6 of the latch-carrier upon the arm f^{2x} , then in its normal position, against the stop b^x .

Owing to length of the feeler-arm f^{2x} and to the adjustability of the feeler support or fulcrum a very delicate and fine adjustment of the parts can be effected, so that the opera-

tion of the filling-supplying mechanism can be timed to a nicety, and in practice it is only necessary to leave enough filling on the filling-carrier to extend once across the lay after the predetermined point of exhaustion has been reached—that is, the amplitude of movement of the feeler will gradually decrease from the first filling-induced movement of the feeler until the movement of the feeler is so slight that the arm f^{2x} will not be withdrawn from operative position relative to the latch-carrier.

A knock-off lever n' n^2 for the shipper-lever N^x is fulcrumed on the breast-beam at n , (see Fig. 1,) the end of the lever-arm n^2 being bent over, as at n^3 , in front of the outer end of the usual weft or filling fork slide m , longitudinally slotted at m' (see Fig. 4) for the upper end of the weft-hammer and provided with a filling-fork m^x , pivoted at m^2 , and provided with the usual tail m^3 to be engaged by the hook m^4 , pivotally connected with the upper end of the weft-hammer when the hook is not tilted, owing to the failure of the filling. Should the filling break, therefore, or be accidentally exhausted, the outward movement of the weft-hammer will operate through the hook m^4 and the tail of the fork to move the slide m out and into engagement with the end n^3 of the knock-off lever, moving the same against a suitable spring s^3 to release the shipper-handle from its holding-notch, and through suitable belt-shipping devices (not shown) the loom will be stopped. The end of the arm n^2 is notched, as at m^4 , Fig. 1, to embrace an upturned arm d^4 , loosely mounted on the rock-shaft d' and having a downturned end d^5 (partially shown in Figs. 2 and 3) to effect disengagement of the take-up pawl and ratchet when the loom is stopped. Thus the apparatus herein shown and described will operate to automatically effect a change of filling when the filling in the shuttle has been exhausted to a predetermined extent, and the loom will be automatically stopped upon failure of the filling due to breakage.

The mechanisms controlled respectively by the amount of filling in the shuttle and by the presence or absence of filling are operated by a common actuator—viz., the weft-hammer—as herein shown and described.

The relative lengths of the feeler and feeler-arm f^{2x} make it possible for a very slight movement of the feeler to effect a proportionally-large movement of the free end of the arm f^{2x} , providing thereby for a much closer action of the feeler and the filling-supplying mechanism controlled thereby than has been heretofore possible.

My invention is not restricted to the precise details of construction and arrangement herein shown and described, as the same may be modified or rearranged in various particulars without departing from the spirit and scope of my invention.

Having described my invention, what I

claim as new, and desire to secure by Letters Patent, is—

1. In a loom, automatic filling-supplying mechanism, means to control the time of its operation, and an actuator for said means, the latter including a filling-feeler intermittently moved by engagement with the filling in the shuttle until exhausted to a predetermined extent, and a member moved into inoperative position by such movements of the feeler, failure of the latter to render the said member inoperative effecting cooperation of said means and the actuator therefor.

2. In a loom, automatic filling-supplying mechanism, means to control the time of its operation, including a filling-feeler intermittently moved by engagement with the filling in the shuttle until exhausted to a predetermined extent, and a device moved into inoperative position by such movements of the feeler, and a weft-hammer, failure of the feeler to render the device inoperative effecting cooperation of the controlling means and the weft-hammer.

3. In a loom, automatic filling-supplying mechanism, means to control the time of its operation, and a vibrating actuator for said means, the latter including a filling-feeler intermittently engaged and moved by the filling in the shuttle until exhausted to a predetermined extent, and a latch moved into inoperative position by each of such movements of the feeler, failure of the latter to render the latch inoperative effecting engagement of the latch and said vibrating actuator.

4. In a loom, automatic filling-supplying mechanism, means to control the time of its operation, and a vibrating weft-hammer, said means including a filling-feeler intermittently engaged and moved by the filling in the shuttle until exhausted to a predetermined extent, subsequent engagement of the filling by the feeler failing to move the latter, and a normally-operative latch moved into inoperative position by each filling-induced movement of the feeler, failure of the feeler to render the latch inoperative when the lay has beaten up effecting operative engagement of the latch and vibrator.

5. In a loom, automatic filling-supplying mechanism, controlling means therefor, and a weft-hammer, said means including a feeler intermittently engaged and moved by the filling in the shuttle until exhausted to a predetermined extent, a slide, and a normally-operative latch mounted thereon and moved into operative position by filling-induced movement of the feeler, insufficient movement of the latter permitting the latch to be engaged by the weft-hammer, to thereby actuate the slide and effect the operation of the filling-supplying mechanism.

6. In a loom, automatic filling-supplying mechanism, means to control the time of its operation, and an actuator for said means, the latter including a feeler mounted on an adjustable fulcrum and intermittently moved

by engagement with the filling in the shuttle until exhausted to a predetermined extent, and a normally-operative latch moved into inoperative position, upon filling-induced movement of the feeler, failure of the feeler to inoperatively position the latch effecting engagement of the latter and the actuator.

7. In a loom, automatic filling-supplying mechanism, means to control the time of its operation, and an actuator for said means, the latter including a latch maintained inoperative until the filling in the shuttle has been exhausted to a predetermined extent, subsequent engagement of the latch and the actuator effecting the operation of the filling-supplying mechanism, combined with stopping means for the loom, a filling-fork, and connections between it and said stopping means, to stop the loom upon failure of the filling.

8. In a loom, automatic filling-supplying mechanism, means to control the time of its operation, and a weft-hammer, said means including a filling-feeler intermittingly movable by engagement with the filling in the shuttle until exhausted to a predetermined extent, a slide having a rocking latch-carrier thereon provided with a latch, the feeler having a connected arm engaging the carrier and maintaining the latch operative except when moved by engagement with the filling, and a spring to render the latch inoperative when the carrier is released, the latch-carrier having a cam-surface thereon to be engaged by the weft-hammer, to rock the latch-carrier after each release thereof by the feeler, failure of the latter to release the said carrier permitting engagement of the latch and weft-hammer, to move the slide and effect the operation of the filling-supplying mechanism.

9. In a loom provided with filling-supplying mechanism, a pivotally-mounted feeler to intermittingly engage and be moved by the filling in the shuttle as the lay beats up, an extended arm movable with the feeler, a sliding support, and a spring-controlled latch-carrier mounted on said sliding support and having a latch, the extended arm of the feeler when beneath the carrier maintaining the latch in operative position, withdrawal of said arm, due to filling-induced movement of the feeler until the filling has been nearly exhausted, permitting movement of the latch into inoperative position, combined with a vibrator to engage the latch when in operative position and move the sliding support, and controlling connections between the support and the filling-supplying mechanism.

10. In a loom, the weft-hammer, a shuttle containing a supply of filling, filling-supplying mechanism, and controlling means for said mechanism, actuated by the weft-hammer, said means including a filling-feeler operatively movable by intermittingly engagement with the filling in the shuttle until exhaustion of the filling to a predetermined extent, a latch, and devices intermediate it and

the feeler, to effect withdrawal of the latch from the weft-hammer path while the filling-induced movement of the feeler continues.

11. In a loom, the weft-hammer operatively movable on alternate picks, a shuttle containing a supply of filling, filling-supplying mechanism, and controlling means therefor actuated by operative movement of the weft-hammer, said means including a filling-feeler movable by engagement with the filling in the shuttle until exhaustion of the filling to a predetermined extent, filling-induced movement of the feeler and operative movement of the weft-hammer occurring successively, a latch, and controlling devices therefor to render it inoperative, governed by filling-induced movement of the feeler, cessation of such movement maintaining the latch in the path of and to be engaged by the weft-hammer in its next operative movement, to effect the actuation of the filling-supplying mechanism.

12. In a loom provided with filling-supplying mechanism, controlling means therefor, including a feeler intermittingly moved by engagement with the filling in the shuttle until exhausted to a predetermined extent, an arm rigidly connected with and longer than the feeler, a slide-bar, and a latch supported thereon, and devices between the arm and the latch to control the position of the latch, feeler-induced movement moving the arm to effect movement of the latch into inoperative position, combined with a vibrating actuator, the latch extending into the path of and to be moved by the actuator when exhaustion of the filling prevents operative movement of the feeler-arm.

13. In a loom, filling-supplying mechanism, stopping means for the loom, and a controlling mechanism for each, governed respectively by exhaustion of the filling to a predetermined extent and failure of the filling, and a common actuator for said controlling mechanisms, the controlling mechanism for the stopping means directly actuating the latter upon filling failure, whereby change of filling will be effected upon exhaustion of the filling in the shuttle to a predetermined extent, and the loom will be stopped at once upon failure of the filling.

14. In a loom provided with automatic filling-supplying mechanism, controlling means therefor including a feeler having a connected and extended arm, a vertical fulcrum upon which the feeler is mounted, the lay having a shuttle-box provided with a slot in its front wall, a shuttle containing a supply of filling and having a slot in its side wall to register with the slot in the shuttle-box wall when the shuttle is positioned, whereby the feeler can be intermittingly engaged and be moved by the filling in the shuttle until the filling is exhausted to a predetermined extent, a slide-bar, a horizontally-pivoted latch-carrier mounted thereon and having a depending latch, a spring to move the latch into inoper-

ative position, a foot on the latch-carrier to at times rest upon the extended arm of the feeler and maintain the latch in operative position, withdrawal of the arm from said foot, 5 due to filling-induced movement of the feeler, effecting the withdrawal of the latch to inoperative position, and an operating rock-shaft having an attached arm in the path of and to be moved by the latch-supporting slide upon 10 exhaustion of the filling to a predetermined extent, combined with a weft-hammer to engage the latch when in its operative position and thereby move the slide.

15 15. In a loom, a feeler adapted to intermittently engage the filling in the shuttle and be moved thereby a constantly-decreasing distance as the quantity of filling decreases, a slide having a normally-operative latch, an elongated arm connected with the feeler, and 20 cooperating with the latch to permit movement of the same into inoperative position at each filling-induced movement of the feeler until the filling has been exhausted to a predetermined extent, automatic filling-supplying 25 mechanism, connections between it and the slide, and the weft-hammer, to engage the latch when in its operative position and thereby move the slide, such movement of the slide acting through the intervening connections 30 to effect the operation of the filling-supplying mechanism.

16. In a loom, a slotted stand having an upright sleeve thereon, provided with a lug entering the slot, an adjusting-screw mounted 35 in the stand and extended through a threaded hole in the lug to adjust the position of the sleeve, a feeler fulcrumed upon the sleeve, a spring to move the feeler in one direction, an extended arm rigidly movable with the 40 feeler and normally held by the spring against a stop, the feeler engaging intermittently the filling in the shuttle and being moved thereby in opposition to the spring and in accordance with the amount of filling present, filling-supplying mechanism, controlling means 45 therefor operative upon failure of the feeler to substantially move the arm connected therewith, and a clamping-stud extended through the sleeve, to retain it in adjusted 50 position.

17. In a loom provided with automatic filling-supplying mechanism, a stand having parallel guideways, a filling-fork slide movable in one of said guideways, a slide-bar movable 55 in the other guideway, and having a pivotally-mounted latch-carrier thereupon provided with a latch, a filling-feeler to intermittently engage and be moved by the filling in the shuttle until exhausted to a predetermined extent, an elongated arm movable 60 with the feeler and adapted to engage the latch-carrier and maintain the latch operative, the weft-hammer adapted to engage the latch and thereby move the slide-bar upon exhaustion of the filling to a predetermined extent, a setting-cam on the latch-carrier to be 65 engaged by the weft-hammer after each en-

gagement of the feeler with the filling in the shuttle, and operating connections between the filling-supplying mechanism and the slide-bar and operative by movement of the 70 latter.

18. In a loom, automatic filling-supplying mechanism, controlling means therefor, and an actuator for the latter, the said means including a member normally in position to be 75 engaged and moved by the actuator, a feeler intermittently engaged and moved by the filling in the shuttle until exhausted to a predetermined extent, filling-induced movement 80 of the feeler rendering said normally-operative member inoperative, and a device to prevent return of the feeler to normal position until after the actuator has passed the critical point in its movement. 85

19. In a loom, a feeler to intermittently engage and be moved by the filling in the shuttle until exhausted to a predetermined point, filling-supplying mechanism, controlling devices 90 between it and the feeler, rendered inoperative by filling-induced movement of the latter, an actuator for said devices when in operative condition, and means to prevent the return of the feeler to normal position after each filling-induced movement until the ac- 95 tuator has passed the critical point in its movement.

20. In a loom, automatic filling-supplying mechanism, means to control its operation, and a weft-hammer, said means including a 100 feeler to intermittently engage and be moved by the filling in the shuttle until exhausted to a predetermined extent, a sliding support having a rocking latch-carrier thereon provided with a latch, an arm connected with 105 the feeler and engaging the latch-carrier to maintain the latch in the path of the weft-hammer except when the feeler is moved by engagement with the filling, a device on the carrier to prevent return of the feeler to normal position after feeling the filling, a spring 110 to render the latch inoperative when the carrier is released, and a cam on the latch-carrier to be engaged by the weft-hammer after it has passed beyond the latch, such engagement 115 rocking the latch-carrier to release the feeler and to return the latch to operative position, non-release of the latch-carrier upon exhaustion of the filling in the shuttle to a predetermined extent permitting engage- 120 ment of the latch and weft-hammer to move the slide and effect the operation of the filling-supplying mechanism.

21. In a loom, the weft-hammer, filling-supplying mechanism, and controlling means for 125 said mechanism, actuated by the weft-hammer, said means including a feeler operatively movable by intermittent engagement with the filling in the shuttle until exhaustion of the filling to a predetermined extent, 130 a latch, devices between it and the feeler, to effect withdrawal of the latch from the path of the weft-hammer at each filling-induced movement of the feeler, and a device to pre-

vent return of the feeler into normal position until after the weft-hammer has moved past the latch.

22. In a loom provided with automatic filling-supplying mechanism, controlling means therefor including a filling-feeler having an elongated hub, a sleeve upon which the hub is loosely mounted, a fixed support for the sleeve, and means to clamp the sleeve in place on its support and to also prevent removal of the feeler.

23. In a loom, automatic filling-supplying mechanism, controlling means therefor including a filling-feeler intermittently moved by engagement with the filling in the shuttle until exhausted to a predetermined extent, a member rendered inoperative by such movement of the feeler, and a device to retard the return of the feeler to normal position, an actuator to operate the controlling means when the filling has been exhausted to a predetermined extent, and means to release the feeler after the actuator has passed said member, and to also restore the controlling means to normal position after operation thereof.

24. In a loom provided with automatic filling-supplying mechanism, means to control the change of filling, and a weft-hammer, said

means including a sliding latch-carrier having a pivotally-mounted latch depending therefrom in the path of the weft-hammer, a feeler to intermittently engage and be moved by the filling in the shuttle until exhausted to a predetermined extent, an arm movable with the feeler and normally acting upon the latch-carrier to maintain the latch operative, a fixed stop for the arm, and a cam on the latch-carrier beyond the latch, filling-induced movement of the feeler permitting movement of the latch into inoperative position, the latch-carrier thereafter preventing return of the feeler to normal position until the weft-hammer has passed beyond the latch and engaged the cam, engagement of the latch by the weft-hammer on one stroke operating the controlling means, the latch tipping on the return stroke of the weft-hammer as the latter moves under it.

In testimony whereof I have signed my name to this specification in the presence of two subscribing witnesses.

JONAS NORTHROP.

Witnesses:

EDWARD S. HARDING,
GEO. OTIS DRAPER.