

(19) World Intellectual Property Organization
International Bureau



(43) International Publication Date
14 September 2006 (14.09.2006)

PCT

(10) International Publication Number
WO 2006/095134 A1

(51) International Patent Classification:
B01J 31/02 (2006.01) *C10L 1/00* (2006.01)
C07C 67/03 (2006.01)

(21) International Application Number:
PCT/GB2006/000682

(22) International Filing Date:
27 February 2006 (27.02.2006)

(25) Filing Language: English

(26) Publication Language: English

(30) Priority Data:
0505064.6 11 March 2005 (11.03.2005) GB

(71) Applicant (for all designated States except US): **THE QUEEN'S UNIVERSITY OF BELFAST** [GB/GB]; University Road, Belfast BT7 1NN (GB).

(72) Inventors; and

(75) Inventors/Applicants (for US only): **EARLE, Martin, John** [GB/GB]; The Queen's University of Belfast, University Road, Belfast BT7 1NN (GB). **SEDDON, Kenneth, Richard** [GB/GB]; The Queen's University of Belfast, University Road, Belfast BT7 1NN (GB). **PLECHKOVA, Natalia, Vladimirovna** [RU/GB]; The Queen's University of Belfast, University Road, Belfast BT7 1NN (GB).

(74) Agents: **HAMER, Christopher, Klatt et al.**; Mathys & Squire, 120 Holborn, London EC1N 2SQ (GB).

(81) Designated States (unless otherwise indicated, for every kind of national protection available): AE, AG, AL, AM, AT, AU, AZ, BA, BB, BG, BR, BW, BY, BZ, CA, CH, CN, CO, CR, CU, CZ, DE, DK, DM, DZ, EC, EE, EG, ES, FI, GB, GD, GE, GH, GM, HR, HU, ID, IL, IN, IS, JP, KE, KG, KM, KN, KP, KR, KZ, LC, LK, LR, LS, LT, LU, LV, LY, MA, MD, MG, MK, MN, MW, MX, MZ, NA, NG, NI, NO, NZ, OM, PG, PH, PL, PT, RO, RU, SC, SD, SE, SG, SK, SL, SM, SY, TJ, TM, TN, TR, TT, TZ, UA, UG, US, UZ, VC, VN, YU, ZA, ZM, ZW.

(84) Designated States (unless otherwise indicated, for every kind of regional protection available): ARIPO (BW, GH, GM, KE, LS, MW, MZ, NA, SD, SL, SZ, TZ, UG, ZM, ZW), Eurasian (AM, AZ, BY, KG, KZ, MD, RU, TJ, TM), European (AT, BE, BG, CH, CY, CZ, DE, DK, EE, ES, FI, FR, GB, GR, HU, IE, IS, IT, LT, LU, LV, MC, NL, PL, PT, RO, SE, SI, SK, TR), OAPI (BF, BJ, CF, CG, CI, CM, GA, GN, GQ, GW, ML, MR, NE, SN, TD, TG).

Published:

- with international search report
- before the expiration of the time limit for amending the claims and to be republished in the event of receipt of amendments

For two-letter codes and other abbreviations, refer to the "Guidance Notes on Codes and Abbreviations" appearing at the beginning of each regular issue of the PCT Gazette.



WO 2006/095134 A1

(54) Title: PRODUCTION OF BIO-DIESEL

(57) Abstract: Use of ionic liquids in the production of bio-diesel, wherein the ionic liquid is both a solvent and catalyst, and is stable under reaction conditions.

Production of Bio-diesel

The present invention relates to a method of producing bio-diesel, and, more specifically, to a method of producing bio-diesel using a stable ionic liquid as both solvent and catalyst.

Bio-diesel is the name given to a clean burning alternative fuel produced from domestic, and renewable, resources. Bio-diesel contains no petroleum, but can be blended at any level with petroleum diesel to create a bio-diesel blend. It can be used in compression-ignition (diesel) engines with little or no modifications. Bio-diesel is considered simple to use, biodegradable, non-toxic, and essentially free of sulfur and aromatics.

Bio-diesel is defined as mono-alkyl esters of long chain fatty acids derived from vegetable oils or animal fats. Generally, Bio-diesel is made through transesterification of animal fat, wherein the glycerin is separated from the fatty acid methyl ester. Alternatively, it can be made through the esterification of vegetable oils, wherein the water byproduct is separated from the final fatty acid methyl ester.

Bio-diesel must be produced to strict industry specifications (ASTM D6751) in order to ensure proper performance and is the only alternative fuel to have fully completed the health effects testing requirements of the 1990 Clean Air Act Amendments. Bio-diesel that meets ASTM D6751 is registered with the Environmental Protection Agency as a legal motor fuel for sale and distribution. The term "bio-diesel" refers to the pure fuel before blending with diesel fuel. Bio-diesel blends are denoted as, "BXX" with "XX" representing the percentage of bio-diesel contained in the blend (ie: B20 is 20% bio-diesel, 80% petroleum diesel).

Bio-diesel is environmentally friendly as it is made from renewable resources and has lower emissions compared to petroleum diesel. It is also less toxic than table salt and biodegrades as fast as sugar.

Many syntheses of bio-diesel are known, typically using acid or base catalysis.

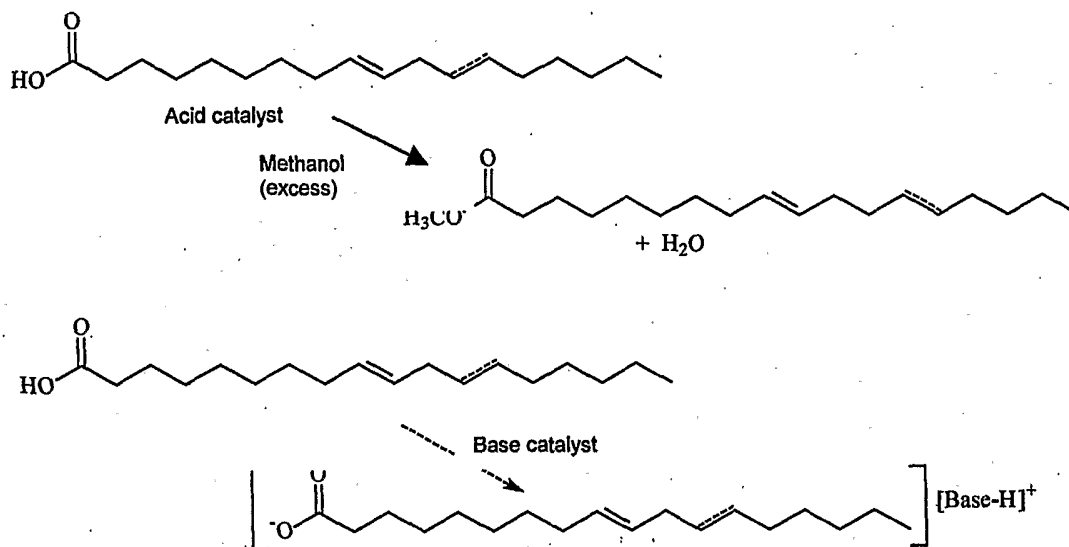

Scheme 1, The acid and base catalysed esterification of fatty acids.

For fatty acids (vegetable oil), the acid catalysed esterification reaction is preferred, as water is the only by-product and this reaction occurs readily. The base catalysed esterification to methyl or ethyl esters usually fails at normal temperatures and pressures, because the catalyst is inactivated by reaction with the carboxylic acid group (Scheme 1).

For fatty esters (animal fats – usually the glycerol ester), both the acid and base catalysed trans-esterification reaction occurs readily. The base catalysed transesterification to methyl or ethyl esters usually requires slightly higher reaction temperatures and pressures, because this is a slower reaction (Scheme 2).

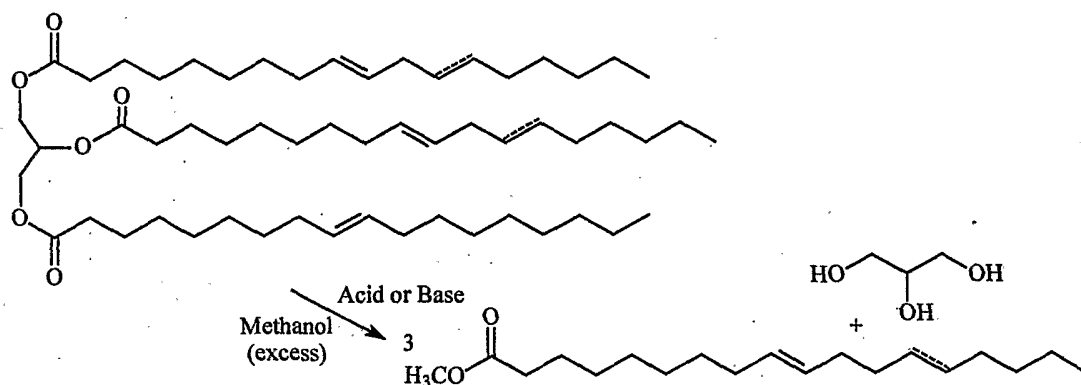

Scheme 2, The acid and base catalysed transesterification of triglycerides, the major constituent of animal fat.

Esterification of various organic acids with C₄-C₁₈ alcohols using 1-octyl-3-methylimidazolium tetrafluoroborate-*para*-toluenesulfonic acid ([OMIM][BF₄]-PTSA), without organic solvent, has been carried out but required excessive heating or microwave irradiation to activate the reaction. Catalysed esterifications at room temperature, using ionic liquids are also known, but a catalyst must be present. However, this only applies to short chain acids (less than 10 carbon atoms) and in no way has been carried out with plant or animal derived fatty acids or esters. (Fraga-Dubreuil, J., Bourahala, K., Rahmouni, M., Bazureau, J. P., Hamelin, J., *Catalysis Communication*, 2002, **3**, 185-190).

Enzymes have also been used with ionic liquids for vacuum-driven lipase-catalysed direct condensation of L-ascorbic acid and fatty acids in ionic liquids, i.e. synthesis of a natural surface active antioxidant. The Brønsted acidic ionic liquid 1-methylimidazolium tetrafluoroborate has also been used for esterification. However, under acidic conditions, [BF₄]⁻ gives HF which is ultra corrosive, highly toxic and dissolves glass.

Also known is chymotrypsin-catalysed transesterification in ionic liquids and ionic liquid/supercritical carbon dioxide; Metallic Lewis acids-catalysed acetylation of alcohols with acetic anhydride and acetic acid in ionic liquids; transesterification/acylation reactions mediated by N-heterocyclic carbene catalysts, and, Lipase-catalysed transesterification in ionic liquids and organic solvents.

[BF₄]⁻ and [PF₆]⁻ ionic liquids are not stable, and imidazolium ionic liquids are not base stable.

The term "ionic liquid" as used herein refers to a liquid that is capable of being produced by melting a solid, and when so produced, consists solely of ions. Ionic liquids may be derived from organic salts.

An ionic liquid may be formed from a homogeneous substance comprising one species of cation and one species of anion, or can be composed of more than one species of cation and/or anion. Thus, an ionic liquid may be composed of more than one species of cation and one species of anion. An ionic liquid may

further be composed of one species of cation, and one or more species of anion. Thus the mixed salts of the invention can comprise mixed salts containing anions and cations.

Thus, in summary, the term "ionic liquid" as used herein may refer to a homogeneous composition consisting of a single salt (one cationic species and one anionic species) or it may refer to a heterogeneous composition containing more than one species of cation and/or more than one species of anion.

A class of ionic liquids which is of special interest is that of salt compositions with melting points below 100°C. Such compositions are mixtures of components which are often liquid at temperatures below the individual melting points of the components.

The term "base" refers to Brønsted bases having the ability to react with (neutralise) acids to form salts. The pH range of bases is from 7.0 to 14.0 when dissolved or suspended in water.

The term "acid" refers to Brønsted acids having the ability to react with (neutralise) bases to form salts. The pH range of acids is from 1.0 to 7.0 when dissolved or suspended in water.

The inventors of the present invention have surprisingly found that it is possible to produce bio-diesel using an ionic liquid which is stable to reaction conditions, thereby allowing continued recycling.

Further, the inventors have surprisingly found that acid or base functionality can be incorporated into the ionic liquid to allow the ionic liquid to act as a catalyst and/or a solvent.

In accordance with the present invention, there is provided a method of obtaining bio-diesel comprising the step of esterifying or trans-esterifying fatty acids derived from plant or animal in the presence of a stable ionic liquid wherein the ionic liquid acts as both a solvent and a catalyst.

Preferably, the ionic liquid is acidic or basic.

Where the ionic liquid is basic, it may comprise a basic cation and a neutral anion, or a neutral cation and a basic anion, or both a basic cation and a basic anion, or mixture thereof.

Where the ionic liquid is acidic, it may comprise an acidic cation and a neutral anion, or a neutral cation and an acidic anion, or both an acidic cation and an acidic anion, or mixture thereof.

The basic cation preferably has the formula:

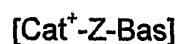

wherein: Cat^+ is a cationic species comprising or consisting of ammonium, phosphonium, pyrazolium, DBU or DBN;

Z is a covalent bond joining Cat^+ and Bas or 1, 2 or 3 aliphatic linking groups each containing 1 to 10 carbon atoms and each optionally one, two or three oxygen atoms; and

Bas is a basic moiety.

Bas preferably comprises at least one nitrogen, phosphorus, sulphur, oxygen or boron atom.

More preferably, Bas comprises at least one primary, secondary or tertiary amino group.

Still more preferably, Bas is selected from $-\text{N}(\text{R}_1)(\text{R}_2)$, and $-\text{P}(\text{R}_1)(\text{R}_2)$; and wherein R_1 and R_2 can be the same or different and are each selected from hydrogen, linear or branched alkyl, cycloalkyl, aryl and substituted aryl.

R_1 and R_2 , are preferably each selected from hydrogen, methyl, ethyl, *iso*-propyl, butyl, *sec*-butyl, *iso*-butyl, pentyl, hexyl, cyclohexyl, benzyl and phenyl.

More preferably, Bas is selected from $-N(CH_3)_2$ and $-N(CH(CH_3)_2)_2$.

Z may be selected from linear or branched C_1 to C_{18} alkanediyl, substituted alkanediyl, dialkanylether and dialkanylketone.

Preferably, Z is selected from $-(CH_2-CH_2)-$, $-(CH_2-CH_2-CH_2)-$, $-(CH_2-CH_2-CH_2-CH_2)-$, $-(CH_2-CH_2-CH_2-CH_2-CH_2)-$, $-(CH_2-CH_2-CH_2-CH_2-CH_2-CH_2)-$, $-(CH_2-CH_2-O-CH_2-CH_2)-$ and $-(CH_2-CH_2-O-CH_2-CH_2-CH_2)-$.

In accordance with the present invention, $Cat^+-Z-Bas$ may be selected from:



wherein: Bas and Z are as defined above; and

R^b , R^c , and R^d can be the same or different, and are each independently selected from hydrogen, a C_1 to C_{40} , straight chain or branched alkyl group, a C_3 to C_8 cycloalkyl group, or a C_6 to C_{10} aryl group, wherein said alkyl, cycloalkyl or aryl groups are either unsubstituted or may be substituted by one to three groups selected from: C_1 to C_6 alkoxy, C_6 to C_{10} aryl, CN, OH, NO_2 , C_7 to C_{30} aralkyl and C_7 to C_{30} alkaryl.

Preferably, Cat⁺-Z-Bas is selected from:

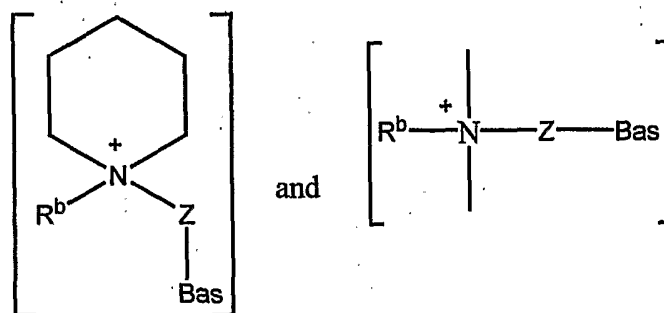

wherein: Z, Bas and R^b are as defined above.

More preferably, Cat⁺-Z-Bas is selected from:

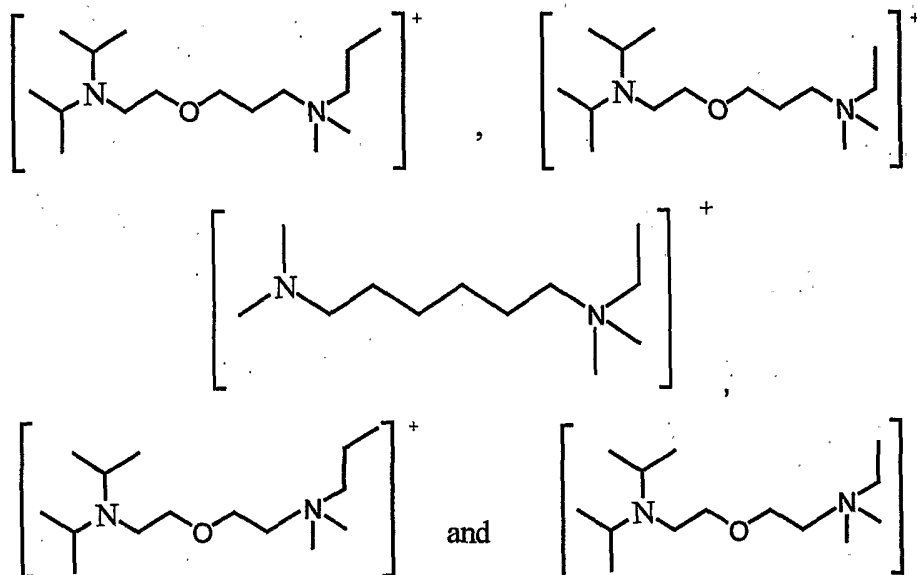

Cat⁺ may also comprise or consist of 1, 3, 5-trialkyl pyrazolium, 1, 2-dialkylpyrazolium, and 1, 2, 3, 5-tetraalkylpyrazolium. Preferably, Cat⁺-Z-Bas is selected from:

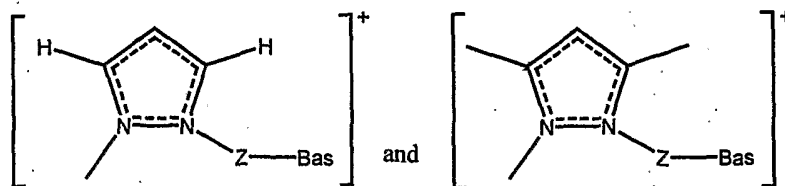

wherein: Z and Bas are as defined above.

Still further, $\text{Cat}^+\text{-Z-Bas}$ may be selected from:

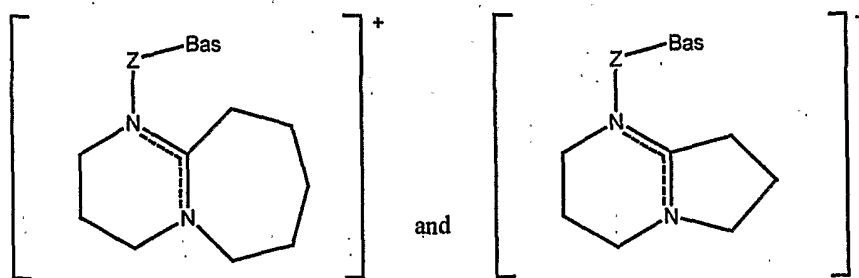

Preferably, $\text{Cat}^+\text{-Z-Bas}$ may also be:

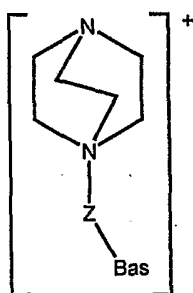

wherein: Bas, Z and R^b are as defined above.

In accordance with the present invention, the basic anion has the formula $[\text{X}_b]^-$, and may be selected from $[\text{F}]^-$, $[\text{OH}]^-$, $[\text{OR}]^-$, $[\text{R-CO}_2]^-$, $[\text{PO}_4]^{3-}$ and $[\text{SO}_4]^{2-}$, wherein R is C_1 to C_6 alkyl.

Preferably, $[\text{X}_b]^-$ is $[\text{OH}]^-$.

Further in accordance with the present invention, the acidic cation preferably has the formula:

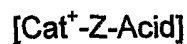

wherein: Cat^+ is a cationic species;

Z is a covalent bond joining Cat^+ and Acid containing 1 to 10 carbon atoms and each optionally one, two or three oxygen atoms; and

Acid is an acidic moiety.

Acid is preferably selected from $-\text{SO}_3\text{H}$, $-\text{CO}_2\text{H}$, $-\text{SO}_3\text{-Ph-R}$, $-\text{SO}_3\text{R}$, $\text{RPO}(\text{OH})_2$ and $\text{R}_2\text{PO}(\text{OH})$; wherein R is, for example, C_1 to C_6 alkyl.

[Cat⁺] may comprise or consist of a heterocyclic ring structure selected from imidazolium, pyridinium, pyrazolium, thiazolium, isothiazolinium, azathiazolium, oxothiazolium, oxazinium, oxazolium, oxaborolium, dithiazolium, triazolium, selenozolium, oxaphospholium, pyrrolium, borolium, furanium, thiophenium, phospholium, pentazolium, indolium, indolinium, oxazolium, isooxazolium, isotriazolium, tetrazolium, benzofuranium, dibenzofuranium, benzothiophenium, dibenzothiophenium, thiadiazolium, pyrimidinium, pyrazinium, pyridazinium, piperazinium, piperidinium, morpholinium, pyranium, annolinium, phthalazinium, quinazolinium, quinazalinium, quinolinium, isoquinolinium, thazinium, oxazinium, azaannulenium and pyrrolidinium.

Preferably, [Cat⁺] may comprise or consist of a heterocyclic ring structure selected from pyridinium, pyrazolium, thiazolium, isothiazolinium, azathiazolium, oxothiazolium, oxazinium, oxazolium, oxaborolium, dithiazolium, triazolium, selenozolium, oxaphospholium, pyrrolium, borolium, furanium, thiophenium, phospholium, pentazolium, indolium, indolinium, oxazolium, isooxazolium, isotriazolium, tetrazolium, benzofuranium, dibenzofuranium, benzothiophenium, dibenzothiophenium, thiadiazolium, pyrimidinium, pyrazinium, pyridazinium, piperazinium, piperidinium, morpholinium, pyranium, annolinium, phthalazinium, quinazolinium, quinazalinium, quinolinium, isoquinolinium, thazinium, oxazinium, azaannulenium and pyrrolidinium

More preferably, [Cat⁺] may comprise or consist of a heterocyclic ring structure selected from pyrazolium, isothiazolinium, tetrazolium, piperidinium, morpholinium and pyrrolidinium.

Preferably, Cat⁺-Z-Acid is selected from:-

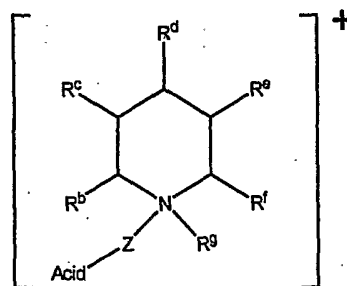
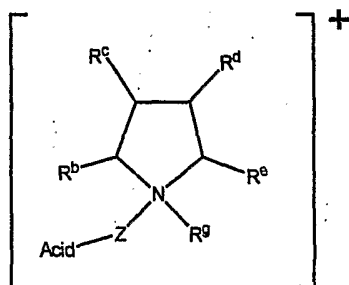
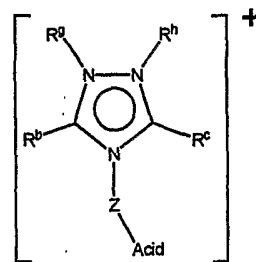
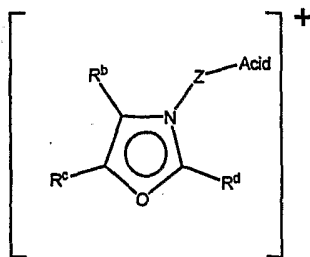
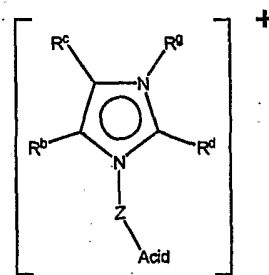
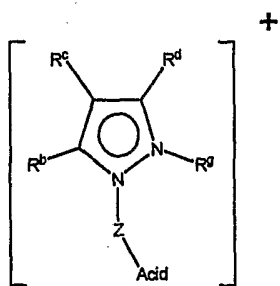
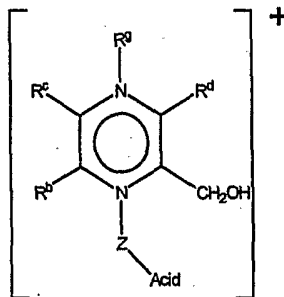
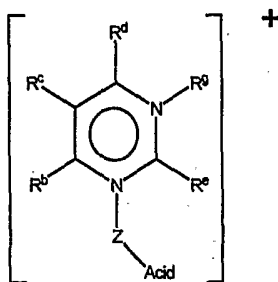
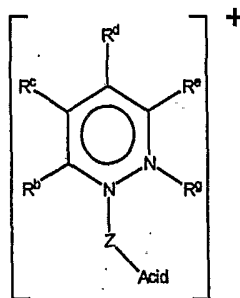
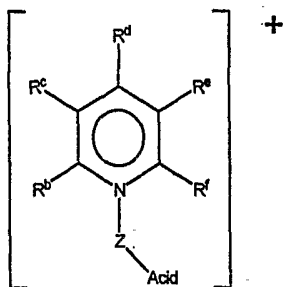

and

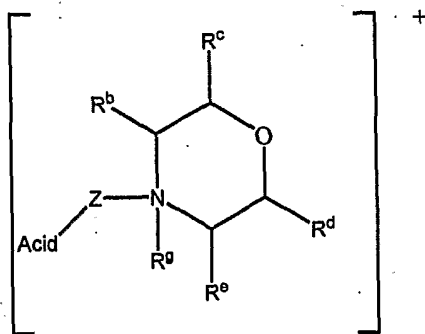

wherein: Acid and Z are as defined above; and

$R^b, R^c, R^d, R^e, R^f, R^g$ and R^h can be the same or different, and are each independently selected from hydrogen, a C_1 to C_{40} , straight chain or branched alkyl group, a C_3 to C_8 cycloalkyl group, or a C_6 to C_{10} aryl group, wherein said alkyl, cycloalkyl or aryl groups are unsubstituted or may be substituted by one to three groups selected from: C_1 to C_6 alkoxy, C_6 to C_{10} aryl, CN, OH, NO_2 , C_7 to C_{30} aralkyl and C_7 to C_{30} alkaryl, or any two of R^b, R^c, R^d, R^e and R^f attached to adjacent carbon atoms form a methylene chain $-(CH_2)_q-$ wherein q is from 8 to 20.

More preferably, $Cat^+ - Z - Acid$ is selected from:-

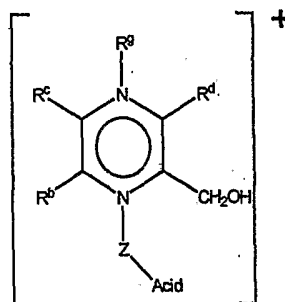
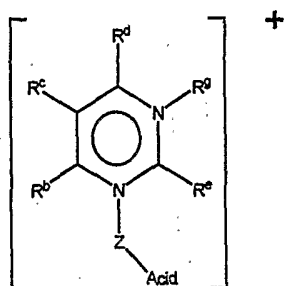
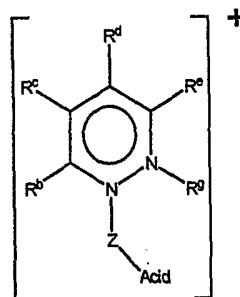
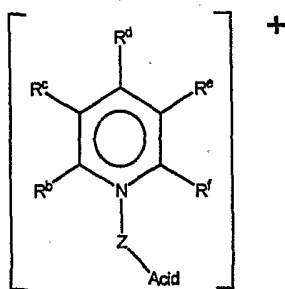

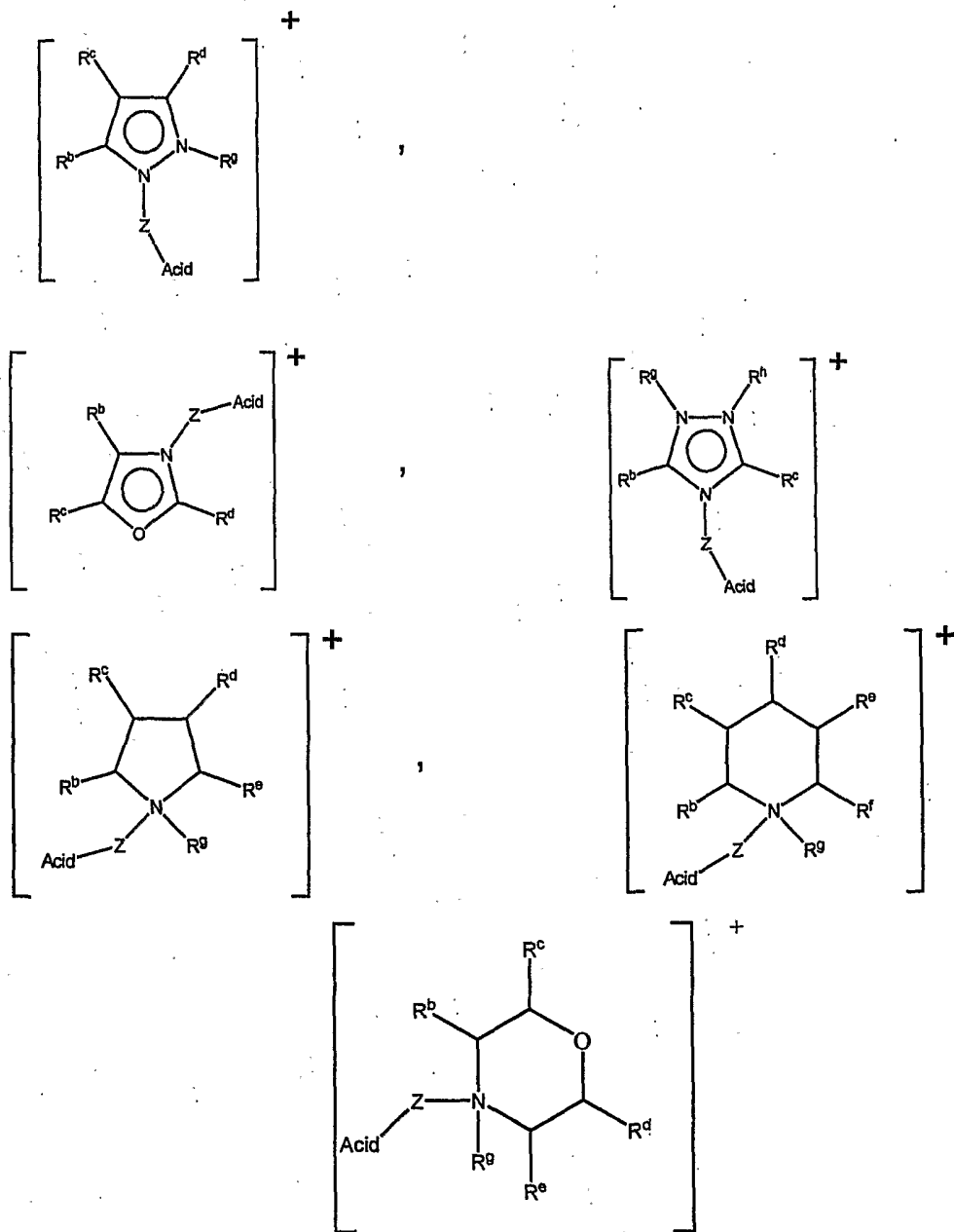

wherein: Acid and Z are as defined above; and

R^b , R^c , R^d , R^e , R^f , R^g and R^h can be the same or different, and are each independently selected from hydrogen, a C_1 to C_{40} , straight chain or branched alkyl group, a C_3 to C_8 cycloalkyl group, or a C_6 to C_{10} aryl group, wherein said alkyl, cycloalkyl or aryl groups are unsubstituted or may be substituted by one to three groups selected from: C_1 to C_6 alkoxy, C_6 to C_{10} aryl, CN, OH, NO_2 , C_7 to C_{30} aralkyl and C_7

to C₃₀ alkaryl, or any two of R^b, R^c, R^d, R^e and R^f attached to adjacent carbon atoms form a methylene chain -(CH₂)_q- wherein q is from 8 to 20.

Most preferably, Cat⁺-Z-Acid is:

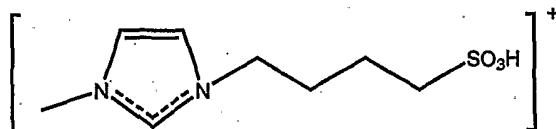

In accordance with the present invention, the acidic anion has the formula [X_a]⁻, and is selected from [HSO₄]⁻, [H₂PO₄]⁻, [HPO₄]²⁻, [HCl₂]⁻ and [HX₂]⁻; wherein X = F, Cl, Br or I.

Preferably, [X_a]⁻ is selected from [HF₂]⁻, [HSO₄]⁻ and [H₂PO₄]⁻.

Where the ionic liquid comprises a basic anion, the neutral cation may comprise or consist of ammonium, phosphonium, pyrazolium, DBU or DBN.

Preferably, the neutral cation is selected from:



wherein: R^a, R^b, R^c, and R^d can be the same or different, and are each independently selected from hydrogen, a C₁ to C₄₀, straight chain or branched alkyl group, a C₃ to C₈ cycloalkyl group, or a C₆ to C₁₀ aryl group, wherein said alkyl, cycloalkyl or aryl groups are unsubstituted or may be substituted by one to three groups selected from: C₁ to C₆ alkoxy, C₆ to C₁₀ aryl, CN, OH, NO₂, C₇ to C₃₀ aralkyl and C₇ to C₃₀ alkaryl.

More preferably, the neutral cation is selected from:

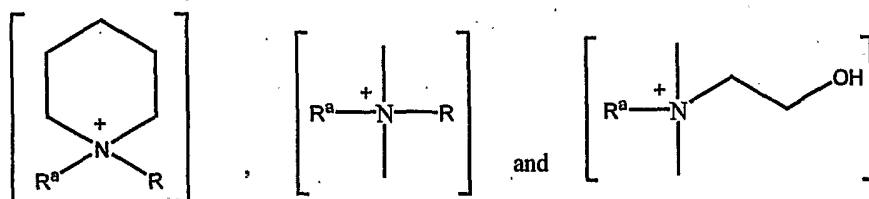

wherein: R^a is as defined above.

Still more preferably, the neutral cation is selected from:

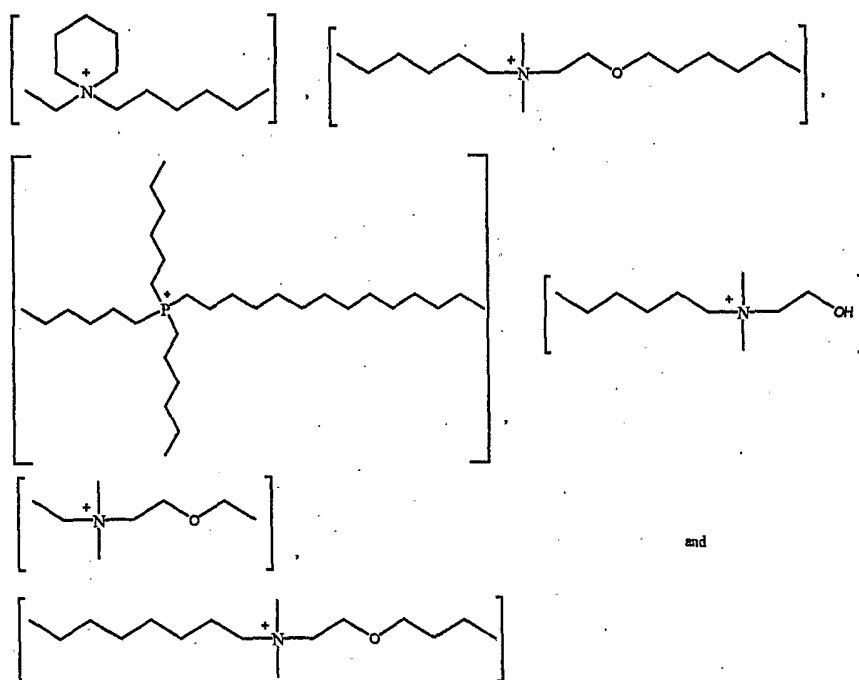

The neutral cation may also comprise or consist of 1, 3, 5-trialkyl pyrazolium, 1, 2-dialkylpyrazolium, or 1, 2, 3, 5-tetraalkylpyrazolium. Preferably, the neutral cation is selected from:

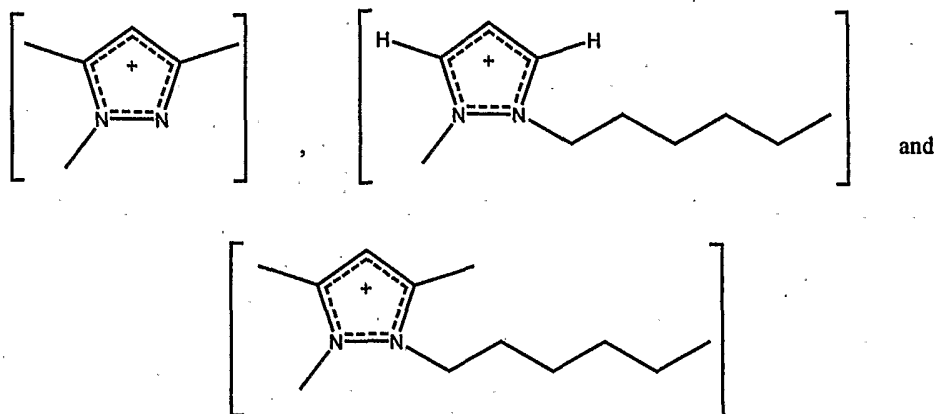

Still further, the neutral cation may be selected from:

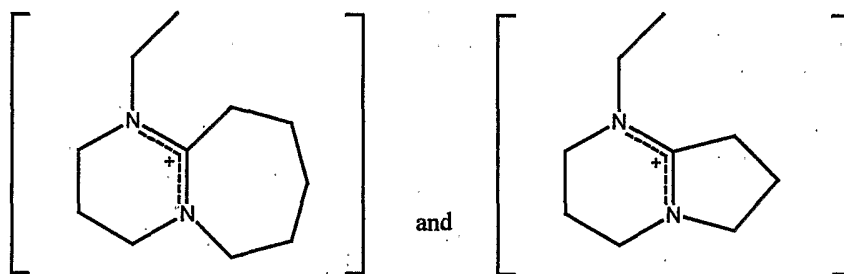

wherein: R^a, R^b, R^c, R^d are a C_1 to C_{40} , straight or branched, alkyl group

Where the ionic liquid comprises an acidic anion, the neutral cation may comprise or consist of a heterocyclic ring structure selected from imidazolium, pyridinium, pyrazolium, thiazolium, isothiazolinium, azathiazolium, oxothiazolium, oxazinium, oxazolium, oxaborolium, dithiazolium, triazolium, selenozolium, oxaphospholium, pyrrolium, borolium, furanium, thiophenium, phospholium, pentazolium, indolium, indolinium, oxazolium, isooxazolium, isotriazolium, tetrazolium, benzofuranium, dibenzofuranium, benzothiophenium, dibenzothiophenium, thiadiazolium, pyrimidinium, pyrazinium, pyridazinium, piperazinium, piperidinium, morpholinium, pyranium, annolinium, phthalazinium, quinazolinium,

quinazolinium, quinolinium, isoquinolinium, thazinium, oxazinium, azaannulenium and pyrrolidinium.

Preferably, where the anion is acidic, the neutral cation preferably comprises or consists of a heterocyclic ring structure selected from pyridinium, pyrazolium, thiazolium, isothiazolium, azathiazolium, oxothiazolium, oxazinium, oxazolium, oxaborolium, dithiazolium, triazolium, selenozolium, oxaphospholium, pyrrolium, borolium, furanium, thiophenium, phospholium, pentazolium, indolium, indolinium, oxazolium, isooxazolium, isotriazolium, tetrazolium, benzofuranium, dibenzofuranium, benzothiophenium, dibenzothiophenium, thiadiazolium, pyrimidinium, pyrazinium, pyridazinium, piperazinium, piperidinium, morpholinium, pyranium, annolinium, phthalazinium, quinazolinium, quinazalinium, quinolinium, isoquinolinium, thazinium, oxazinium, azaannulenium and pyrrolidinium.

More preferably, the neutral cation comprises or consists of a heterocyclic ring structure selected from pyridinium, pyrazolium, thiazolium, pyrimidinium, piperazinium, piperidinium, morpholinium, quinolinium, isoquinolinium and pyrrolidinium.

Preferably the neutral cation is selected from:-

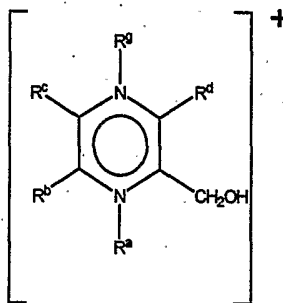
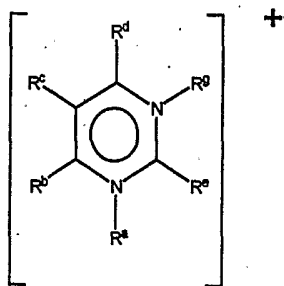
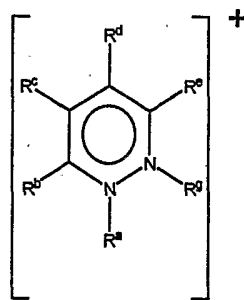
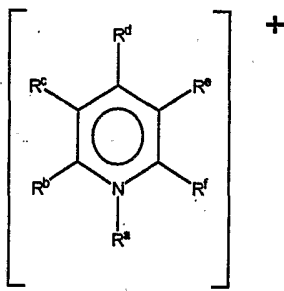

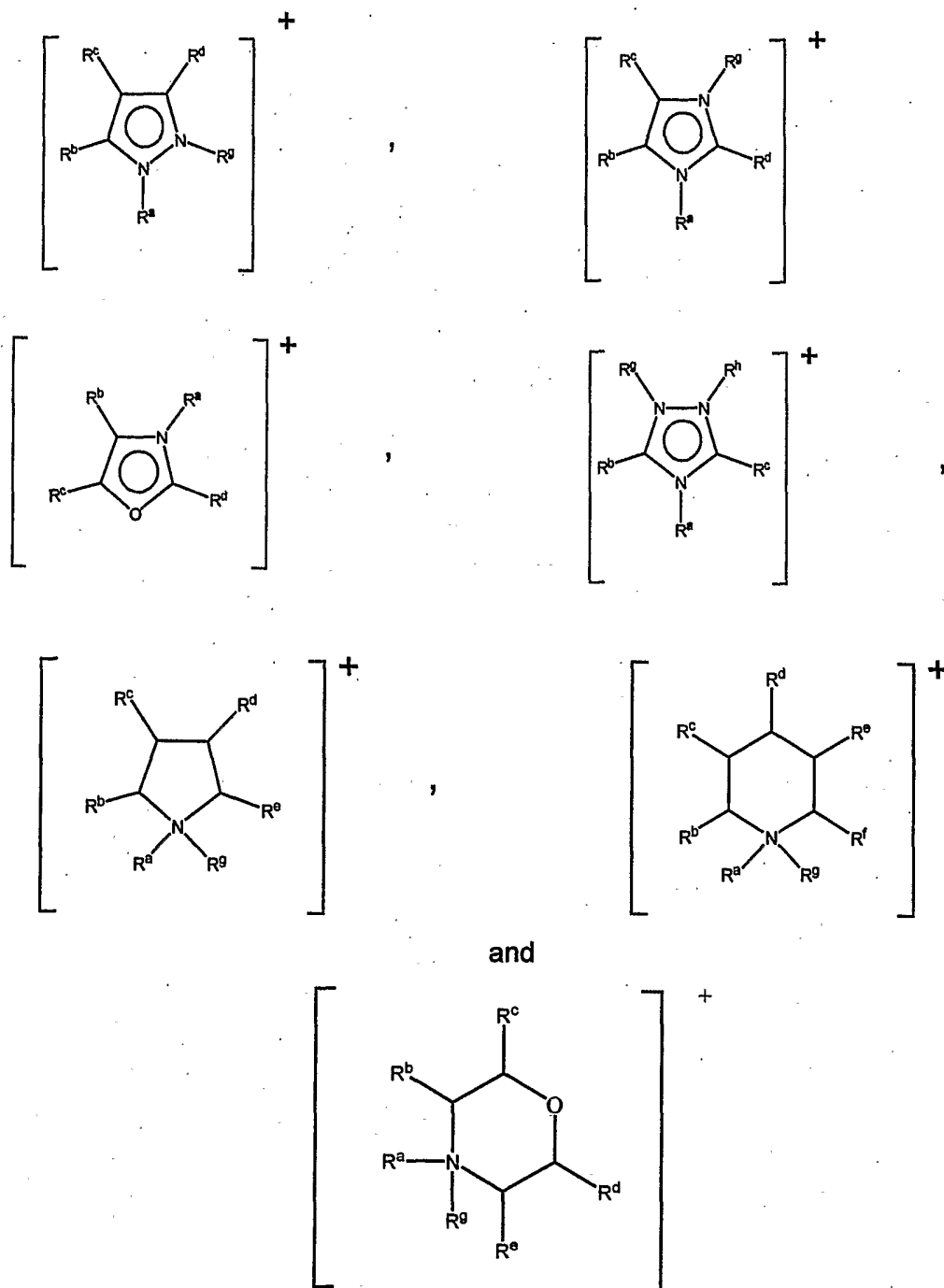

wherein: R^a , R^b , R^c , R^d , R^e , R^f , R^g and R^h can be the same or different, and are each independently selected from hydrogen, a C_1 to C_{40} , straight chain or branched alkyl group, a C_3 to C_8 cycloalkyl group, or a C_6 to C_{10} aryl group, wherein said alkyl, cycloalkyl or aryl groups are unsubstituted or may be substituted by one to three groups selected from: C_1 to C_6 alkoxy, C_6 to C_{10} aryl, CN, OH, NO_2 ,

C₇ to C₃₀ aralkyl and C₇ to C₃₀ alkaryl, or any two of R^b, R^c, R^d, R^e and R^f attached to adjacent carbon atoms form a methylene chain -(CH₂)_q- wherein q is from 8 to 20.

More preferably, the neutral cation is selected from:

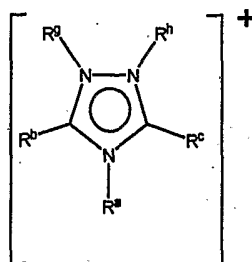
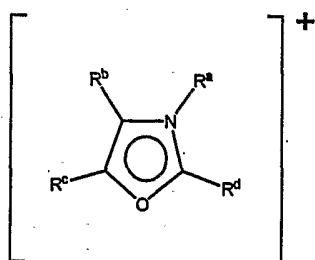
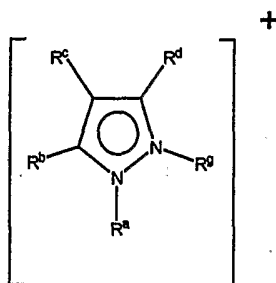
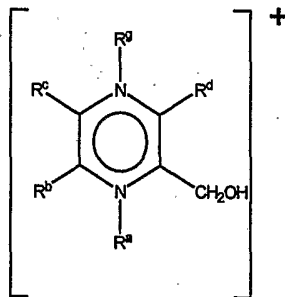
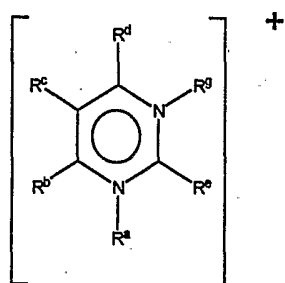
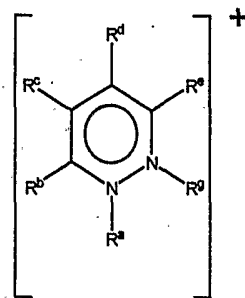
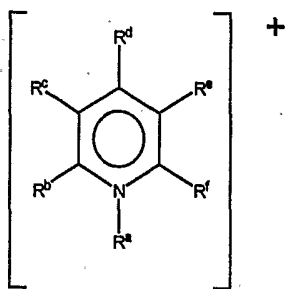

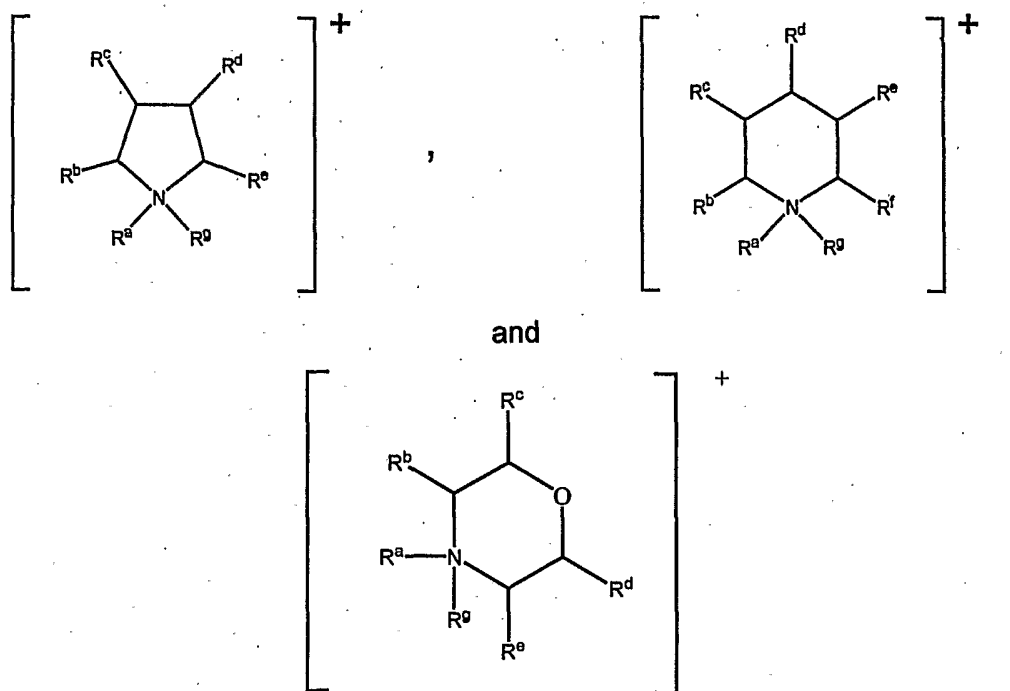

wherein: R^a , R^b , R^c , R^d , R^e , R^f , R^g and R^h are as defined above.

Where the ionic liquid comprises a basic cation or an acidic cation, the neutral anion may be a sulfonate, phosphinate, triflamide (amide), triflate, dicyanamide, oxide (phenoxide) or halide anionic species.

Preferably, the neutral anion is selected from $[C(CN)_3]^-$, $[NTf_2]^-$, $[OTf]^-$, $[R-SO_3]^-$, $[R_2PO_2]^-$, $[Cl]^-$, $[Br]^-$ and $[I]^-$; wherein R is C_1 to C_6 alkyl, or C_1 to C_6 aryl.

The neutral anion may also be selected from $[Me-SO_3]^-$, $[Ph-SO_3]^-$ and $[Me-Ph-SO_3]^-$.

In accordance with any part of the present invention, the plant fatty acid may be derived from vegetables or cereal, for example, rape-seed oil, canola oil or priline.

At the end of the method of the present invention, e.g.:



the ionic liquid will dissolve in solvents (reagents) such as methanol, water or ethanol, and remain separate from the bio-diesel phase. This allows the bio-diesel to be easily separated from the ionic liquid, and the ionic liquid phase can then be recycled.

The present invention will now be further described by way of examples, and with reference to the figures in which:

- Figure 1 is a graph displaying variation of conversion with time for different methanol/catalyst concentrations. (Catalyst = [emim][HSO₄] and determined by GC analysis);
- Figure 2 is a picture showing a separate methyl oleate (upper layer) product layer, wherein the left tube is before reaction (methanol/glycerol/[MIBS][OTf], and the right after reaction;
- Figure 3 is a proton NMR of Run 12 (54% conversion to methyl oleate) showing the glycerol ester peaks at 4.25 and 4.15 and the methyl oleate peak at 3.63 ppm;
- Figure 4 is a proton NMR of Run 1 (99% conversion to methyl oleate) showing the methyl oleate peak at 3.63 ppm and no glycerol ester peaks or ionic liquid peaks; and
- Figure 5 is a proton NMR of Run 1 showing the methanol layer.

The ionic liquids used in the present invention may be produced using known means, or, for example, using reactions as or similar to those described below.

AMMONIUM SALTS

N,N-DIMETHYLETHANOLAMINE IONIC LIQUIDS

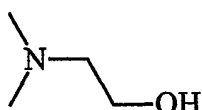

N,N-dimethyl-ethanolamine

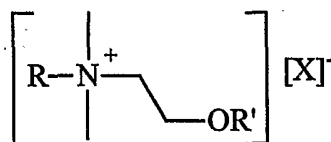

N-alkyl-*O*-alkyl-*N,N*-dimethyl ethanolammonium ionic liquids
or



R = H, alkyl. R' = H, alkyl, X = anion

A range of dimethylethanolamine salts and ionic liquids can be synthesised from dimethylethanolamine and alkyl halides, followed by exchange of the halide ion for other anions. These ionic liquids are useful because dimethylethanolamine is cheap, stable, and the oxygen functionality lowers the melting point of these ammonium salts compared with similar *tetra*-alkylammonium salts. This material is a room temperature ionic liquid.

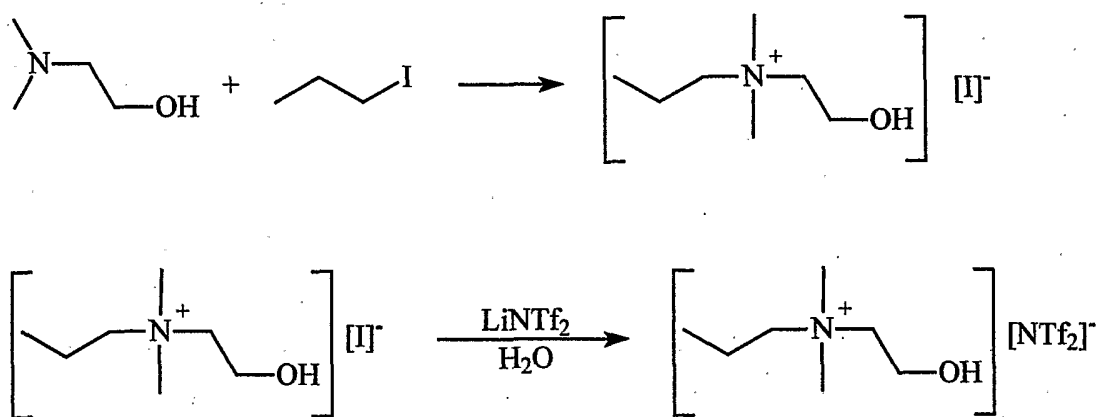

Scheme 1. The synthesis of [*N*_{C3}-*O*_{C0} DMEA][NTf₂]

The alkylation of dimethylethanolamine occurs on the nitrogen atom. Di-alkylation on both the nitrogen and oxygen is observed when at least two moles of alkylating agent are used. Note: a base is also required. Hence a range of mono and dialkyl dimethylethanolamine salts can be synthesised (see Scheme 2).

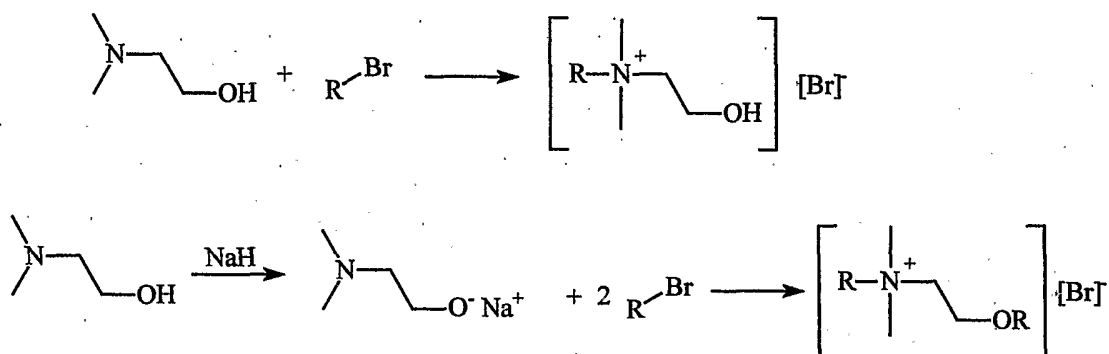

Scheme 2. The general synthesis of dimethylethanolamine ionic liquids.

If different *N*-alkyl and *O*-alkyl groups are required, the product in the first step of Scheme 2 can be alkylated with a different alkyl halide. This is shown in Scheme 3, below.

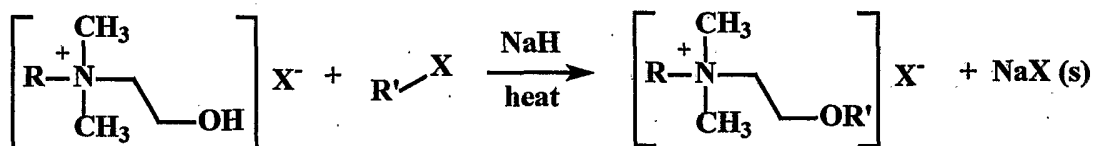

Scheme 3. The synthesis of dimethylethanolamine ionic liquids with different *N*- and *O*-alkyl groups.

DABCO IONIC LIQUIDS

The reaction of an alkyl halide with excess diazabicyclo[2,2,2]octane give a base stable (and basic) series of ionic liquids.

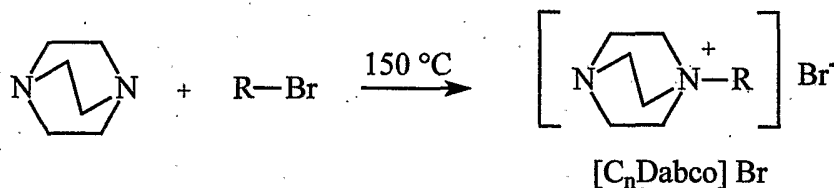

These mono alkyl DABCO bromides have fairly high melting points, but the hexyl, octyl and decyl DABCO bromides are ionic liquids (m.p. <100°C). The decomposition temperatures are all in the 220-250°C range by DSC. The melting point of the [C₆DABCO] bromide ionic liquid (95°C) falls to mp = -55°C (by DSC) for [C₆DABCO][N(SO₂CF₃)₂] which forms a gel at this temperature.

Ethyl DABCO methanesulfonate [C₂DABCO][OSO₂CH₃] (mp 81°C) and hexyl DABCO methanesulfonate have also been synthesised from the reaction of DABCO and ethylmethanesulfonate or hexylmethanesulfonate.

Typical Experimental Procedure

[C_nDABCO] [Br]

Diazobicyclo-[2,2,0]-octene (1.13g, 12.5 mmol) and alkyl bromide (10 mmol) were heated under reflux (or at 150°C which ever is the lower) for 1 to 24 hours. On cooling a precipitate formed. This was dissolved in a minimum quantity of boiling ethyl acetate/isopropanol for C₂ to C₁₀ DABCO bromides and boiling toluene/ethyl acetate for C₁₂ to C₁₈ DABCO bromides. The crystals that formed on cooling were filtered off and dried by heating at 80°C for 4 hours under vacuum (1 mmHg). The compounds were analysed by NMR and DSC. Yields typically 60-80%

[C_nDABCO][OSO₂CH₃]

Diazobicyclo-[2,2,0]-octene (1.13 g, 12.5 mmol) and alkyl methanesulfonate (10 mmol) were heated at 100°C for 1 hour. On cooling a precipitate formed. This was dissolved in a minimum quantity boiling ethyl acetate / isopropanol. The crystals that formed on cooling were filtered off and dried by heating at 80°C for 4 hours under vacuum (1 mmHg). The compounds were analysed by NMR and DSC. Yields typically 70-80%

[C_nDABCO][N(SO₂CF₃)₂]

[C₆DABCO]Br (2.75 g, 10.0 mmol) and lithium bistrifluoromethanesulfinimide (3.15 g, 11 mmol) were each dissolved in water (10 cm³). The two solutions were mixed and a dense ionic liquid phase formed. This was extracted with dichloromethane (3 x 10 cm³), dried over Na₂SO₄, filtered and the solvent

evaporated to give a colourless paste, which became liquid at 25°C. This paste was dried by heating at 80°C for 4 hours under vacuum (1 mmHg). The compounds were analysed by NMR and DSC.

TMEDA SALTS

Tetramethylethylenediamine (TMEDA) ionic liquids can be synthesised from TMEDA and an alkyl bromide as below. The C₂, C₅, C₆, C₈, C₁₂ and C₁₈ alkyl bromides have been made and appear slightly lower melting than the DABCO ionic liquids. [C_nTMEDA]Br where N = 5, 6, 8, 10 are room temperature ionic liquids.

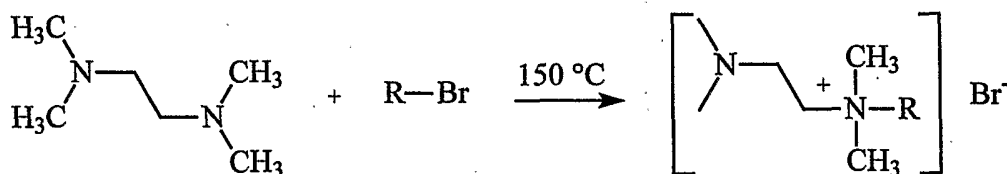

The synthesis of TMEDA ionic liquids.

[C_nTMEDA]Br

Tetramethylethylenediamine (TMEDA) (2.32 g, 20 mmol) and alkyl bromide (25 mmol) were heated under reflux (or at 130°C which ever is the lower) for 1 hour resulting in a dense phase forming. This was cooled to room temperature. For [C₂TMEDA]Br and [C₄TMEDA]Br a crystalline solid formed and for [C₁₈TMEDA]Br, a liquid crystalline material formed. These products were washed with cyclohexane and dried under vacuum (24h at 80°C, 1 mmHg). Yields typically 60-80%.

PYRAZOLIUM IONIC LIQUIDS

The synthesis of pyrazolium ionic liquids from a pyrazole compound and alkyl iodides is feasible but rather expensive. The main difficulty encountered is that pyrazoles are poor nucleophiles and only react slowly with reactive alkylating agents. Maximum yields are approximately 90% with iodides, 60-80% with bromides and <5% with chlorides.

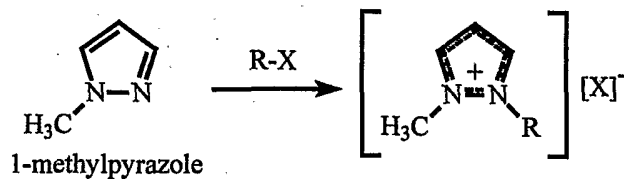

Scheme 4. Synthesis of 1-methylpyrazolium ionic liquids.

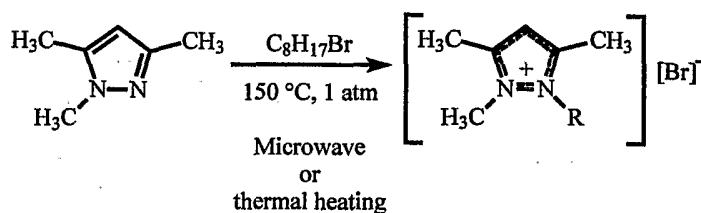

Scheme 5. Synthesis of pyrazolium ionic liquids.

A new synthesis of pyrazolium ionic liquids was invented to eliminate decomposition. The approach used involved the reaction of alkyl methanesulfonate salts with pyrazoles, to obtain methanesulfonate ionic liquids. Using this approach, the elimination side reaction was no longer a significant problem. The redesigned synthesis is shown below in Scheme 6.

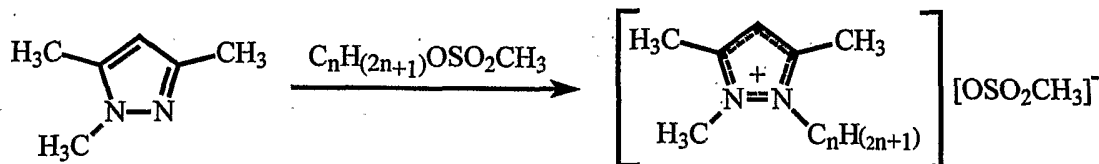
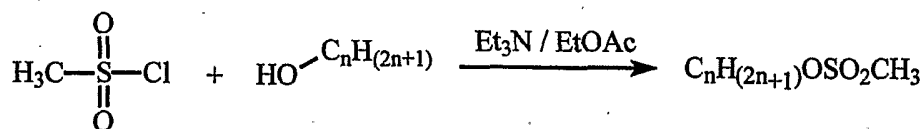

Scheme 6. An alternate synthesis of pyrazolium ionic liquids.

DMAP SALTS

N,N-dimethylaminopyridine (DMAP) ionic liquids are synthesised from DMAP and an alkyl methanesulfonate as below.

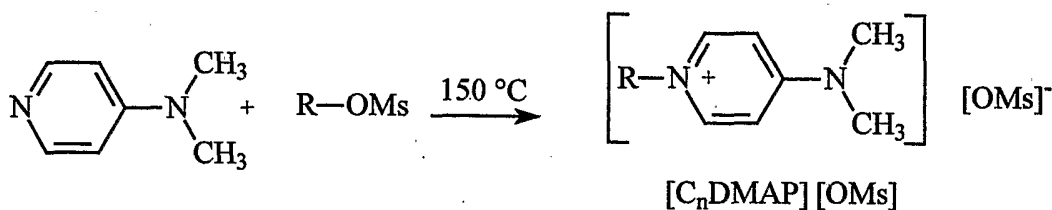

Synthesis of new DMAP ionic liquids.

Dimethylaminopyridine (DMAP) (2.443 g, 20 mmol) and either ethyl or hexyl bromide (25 mmol) were heated under reflux (or at 130°C which ever is the lowest temperature) for 1 hour. On cooling a precipitate formed. This was dissolved in a minimum quantity boiling ethyl acetate / isopropanol for C₂ to C₆ DMAP bromides. The crystals that formed on cooling were filtered off and dried by heat at 80°C for 4 hours under vacuum (1 mmHg). The compounds were analysed by NMR and DSC. Yields typically 60-80%.

Dimethylaminopyridine (DMAP) (2.443 g, 20 mmol) and either ethyl or hexyl methanesulfonate (25 mmol) were heated at 100°C for 1 hour. On cooling a

precipitate formed. This was dissolved in a minimum quantity boiling ethyl acetate / isopropanol for C₂ to C₆ DMAP methanesulfonates. The crystals that formed on cooling were filtered off and dried by heat at 80°C for 4 hours under vacuum (1 mmHg). The compounds were analysed by NMR and DSC. Yields typically 80-85%.

BASICITY

Increasing the distance between the cationic centre and the hindered base increases the basicity of the ionic liquid. This can be achieved by the reaction sequence described below.

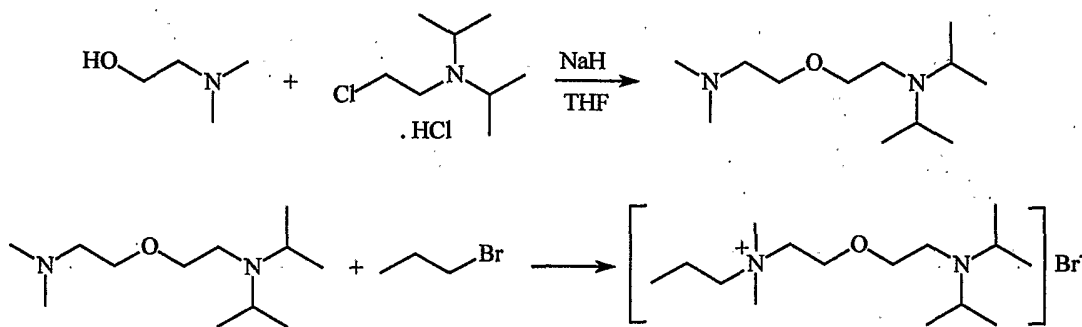

Synthesis of an ionic liquid with a longer distance between cation and the basic group

The 1-chloro-2-(diisopropylamino)ethane hydrochloride was used to alkylate dimethylaminoethanol, the resulting diamine was alkylated with propyl bromide. The quaternisation reaction itself is regiospecific, the diisopropylamino group is non-nucleophilic and cannot be quaternised under the applied conditions. The obtained salt shows a five atom chain between the cation and the basic diisopropylamino group. The metathesis reaction with lithium bistriflimide gave a room temperature ionic liquid. Its structure is shown below.

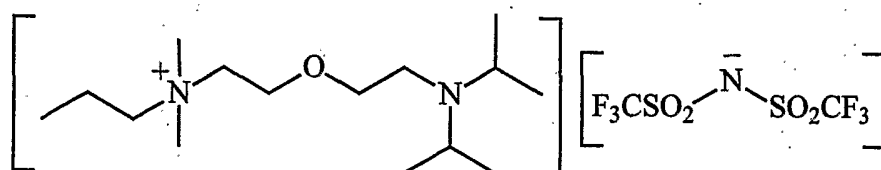

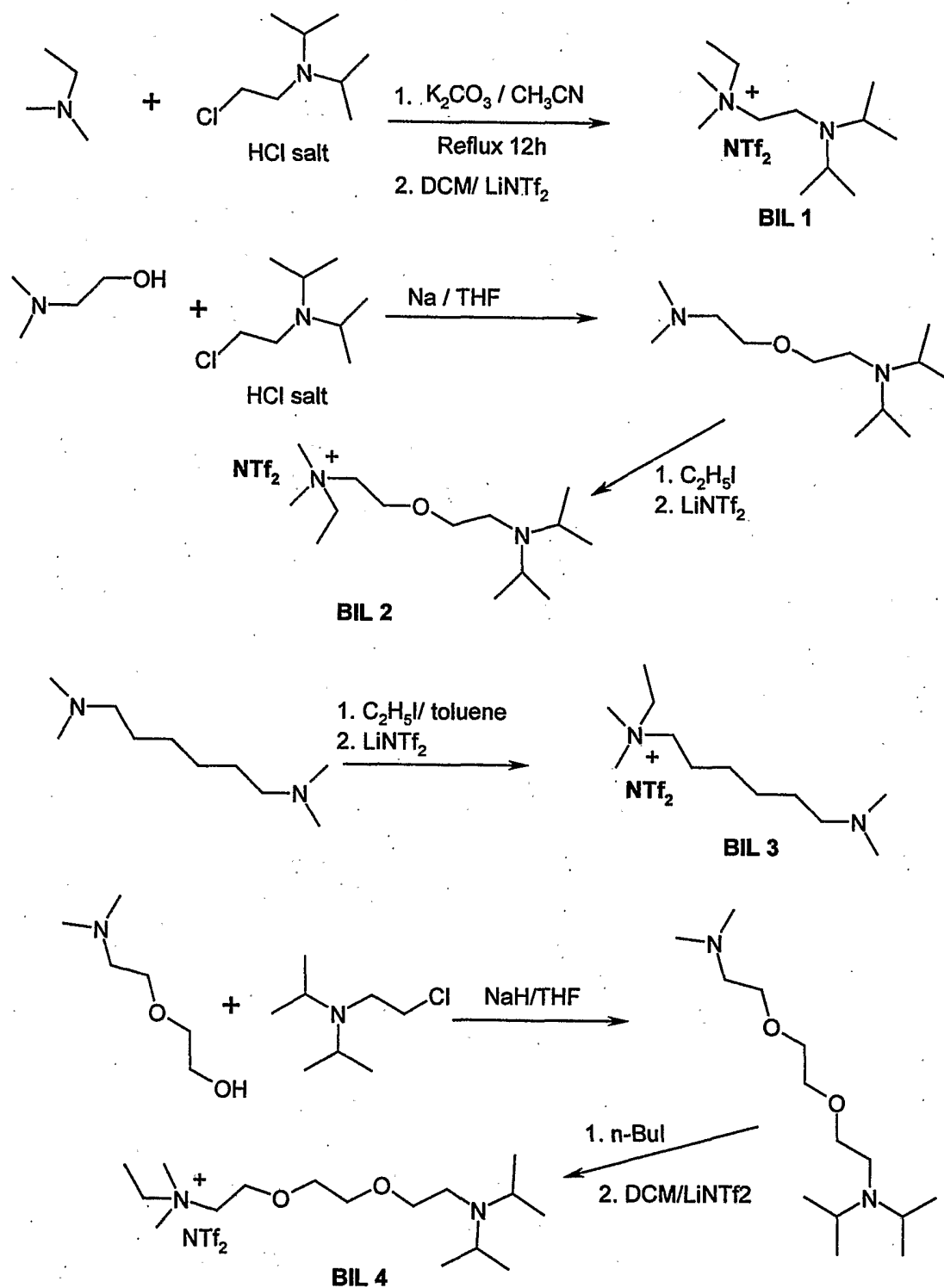

The above scheme shows a synthesis of a range of basic ionic liquids, for example, bearing a 5-atom spacer between the quaternary nitrogen and the basic nitrogen. The general synthetic strategy for the preparation of BIL 1-4 is simple

and versatile and is shown in the Scheme above. A vital part of the synthesis of the base-tethered ionic liquids involves the use of 2-diisopropylaminoethyl chloride reacting with a chosen nucleophilic reagent and is facilitated by the neighbouring group participation from the diisopropylamino moiety. The synthetic strategy for the preparation of **BIL 1, 2 and 4** takes into account the ability to selectively quaternise the pendant amino, imidazolyl or pyridyl groups as against the diisopropylalkylamino group which is non-nucleophilic in nature. The synthetic strategy for the preparation of **BIL 3** makes use of the insolubility of the mono-quaternised diamine which precipitates out of toluene (solvent) thereby preventing it from further reaction with the alkyl halide. In all cases the halide anion associated with the quaternary ammonium salts was subjected to metathesis with lithium bis-triflimide to generate base tethered ionic liquids **BIL 1-4**.

Example 1 – Synthesis of Bio-diesel from Fatty Acids

The esterification reaction (Reaction 1) is an equilibrium reaction driven to completion by using an excess of methanol. As can be seen, water is the only byproduct. The advantage of this method is that the ionic liquid/water/methanol mixture obtained at the end of the reaction is immiscible with the FAME product and forms a separate phase (Reaction 1b). The bio-diesel is isolated by phase separation. Another advantage of this reaction is that the reaction occurs at room temperature and hence no energy input is required in this step.

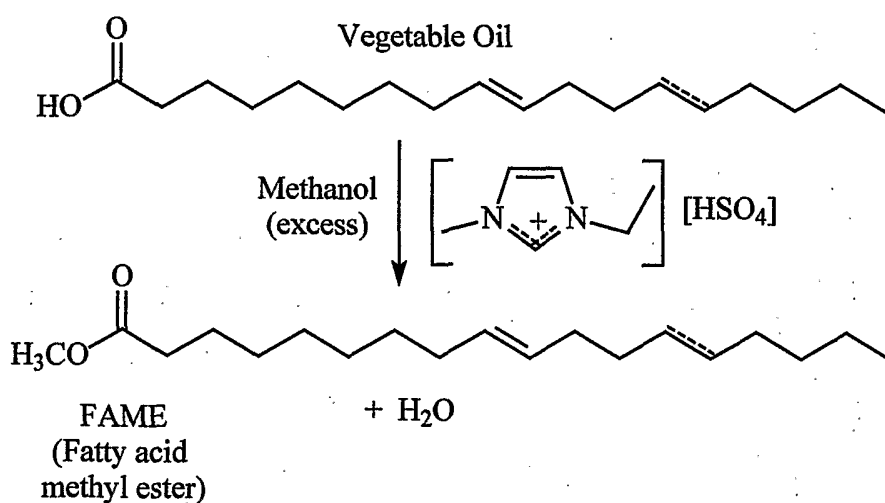

Reaction 1a, The esterification of vegetable oil (Prialene 6927) with [emim][HSO₄].

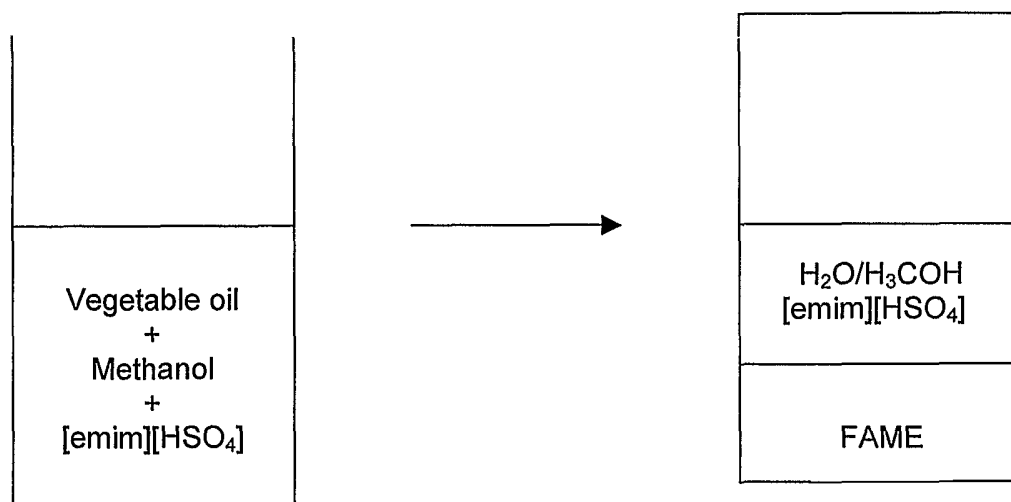

Reaction 1b, The phase behaviour change during Reaction 1a.

As can be seen in Figure 1 and the table below, the reaction proceeds smoothly to give the expected products. With 1% [emim][HSO₄] catalyst the equilibrium yields (Table) are close to what you would expect from a statistical analysis of the reaction (60, 80 and 90% yields for 250%, 500% and 1000% CH₃OH respectively). Where more catalyst is present, (2.5% and 5%) the final yields are greater than 90% (by NMR). The errors in the integration approximate to plus or minus 3%.

Table 1. Final equilibrium yields (144 hours reaction time, 20°C) determined by NMR analysis (Error = ± 3%).

	1% [emim][HSO ₄]	2.5% [emim][HSO ₄]	5% [emim][HSO ₄]
250 % CH ₃ OH	50	57	61
500 % CH ₃ OH	76	-	81
1000 % CH ₃ OH	90	92	98

Table 2. Composition of the 5% [emim][HSO₄] catalysed methyl oleate rich phase (by ¹H NMR).

Component	Mol %	Wt %
FAME (Bio-diesel)	48	87
Fatty acid	2	3
Methanol	48	10
[emim][HSO ₄]	0	0

Example 2 - Synthesis of Bio-diesel from Triglycerides

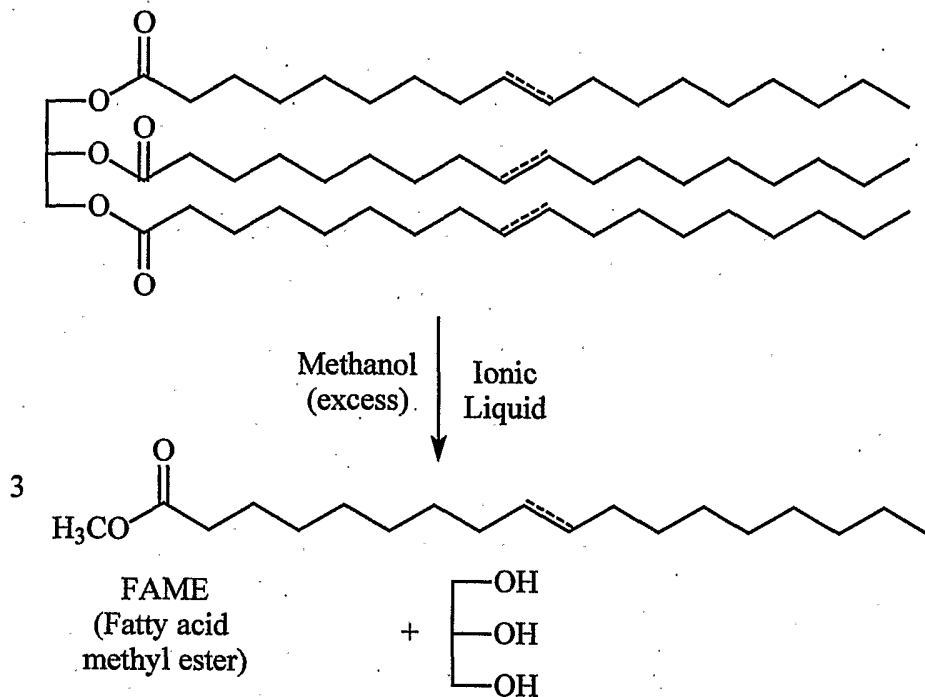

Reaction 2, The animal fat transesterification reaction in ionic liquids

Example 3- Acid Catalysed Transesterifications of Lard (triglycerides)

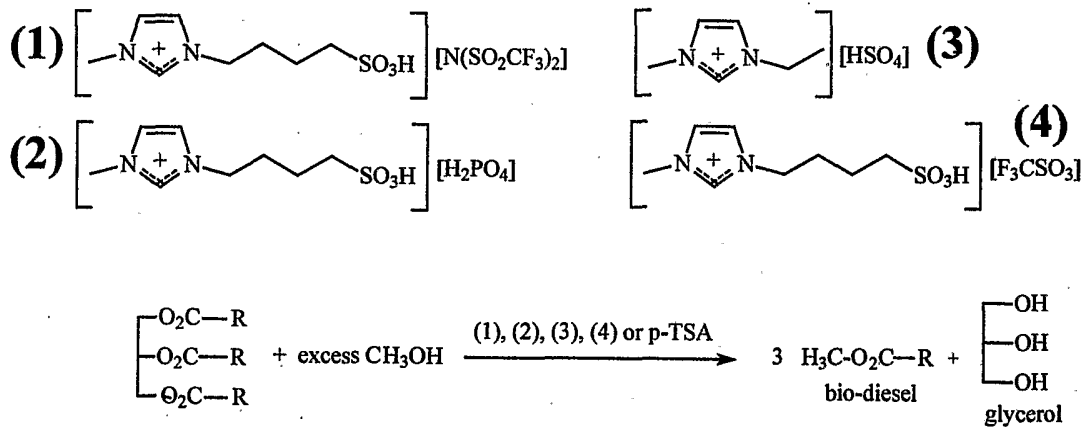

Reaction 3, catalysts used in the acid catalysed transesterification of lard.

Table 3, the acid catalysed transesterification of lard after 0.5 hours in microwave oven lard (1.0g) + 2.0g of methanol and 0.25g of catalyst.

Run	Catalyst (0.25g)	Temperature / °C	% Yield
1	(1)	120	99
2	(2)	140	2
3	(3)	140	30
4	(4)	120	96
5	p-TSA	120	98

As can be seen, the catalysts (1) and (4) {4-(3-methylimidazolium)butanesulfonic acid bistrifluoromethanesulfonylamide and 4-(3-methylimidazolium)butanesulfonic acid trifluoromethanesulfonate} catalyse the reaction well at 120°C (Table 3). This reaction was performed in the microwave over and under pressure to stop the methanol from evaporating. These gave similar results to the conventional acid *para*-toluenesulfonic acid (p-TSA). The ionic liquids have the advantage that they are not volatile and remain in the methanol/glycerol layer. The acid catalysts (2) and (3) are less effective and require higher reaction temperatures to catalyse the reaction. Hence this reaction provides a method for measuring the acidity of these new acidic ionic liquids.

Table 4, the acid catalysed transesterification of lard after 0.5 hours in microwave oven (0.5 g) with methanol (1.0 g) lard and 0.25 g of catalyst.

Run	Catalyst (0.25g)	Temperature / °C	% Yield
6	(4)	90	26
7	(4)	100	43
8	(4)	110	61
9	(4)	120	95
10	(4)	140	99

Table 4 shows that the reaction is temperature dependent and at least 120°C is needed to give over the required 95% conversion to meet the bio-diesel specification. The product forms a separate layer on the surface of the methanol/glycerol layer/ionic liquid layer as shown in Figure 2.

Example 4 - Base Catalysed Transesterifications of Lard (triglyceride)

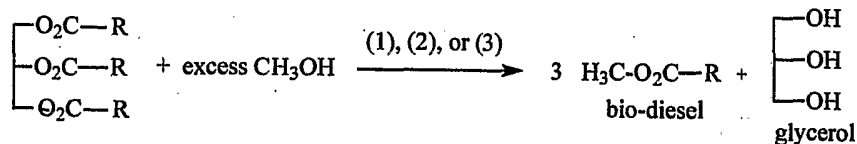
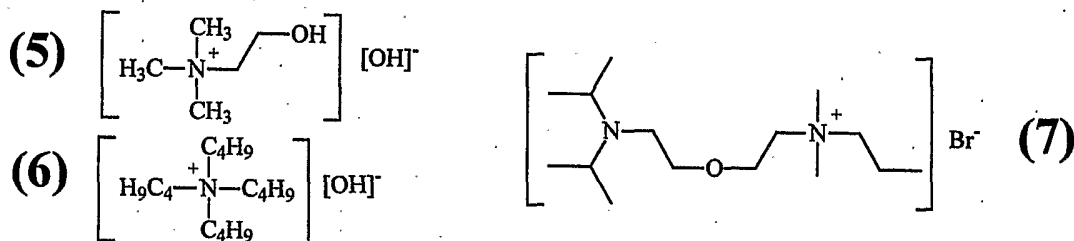

Reaction 4, catalysts used in the base catalysed transesterification of lard after 0.5 hours in microwave oven 1.0 g lard + 2.0g of methanol and 0.25 g of catalyst.

Run	Catalyst (0.25g)	Temperature / °C	% Yield
11	(5)	100	98
12	(6)	100	54
13	(7)	140	8
14	(7)	150	18
15	(7)	160	32

Reaction conditions for Runs 1-15

Animal fat (lard – a triglyceride of mostly oleic acid) (1.0g), methanol (2.0g) and catalyst (0.25g) (unless otherwise stated) (selected from (1) to (7) above) was placed in a microwave tube with a magnetic stirrer flea and heated to the desired temperature for the desired time (See Tables 3, 4 and 5) for conditions. This was cooled to room temperature and the two layers were analysed by NMR (CDCl_3 for fat layer and CD_3OD for methanol layer). The yield was determined by comparing the integration of the $-\text{CH}_2-$ group in the glyceride with the OCH_3 group in the methyl ester of methyl oleate (bio-diesel) (see Figures 3 to 5).

Product isolation: The upper methyl oleate layer was decanted and the dissolved methanol was distilled off by heating to 120°C , or heating to 60°C at 1 mmHg pressure. The product was found to be free of ionic liquid catalyst.

Catalyst recycling: Methanol and water or glycerol were separated from the catalyst by distillation or vacuum distillation. The catalyst could be then recycled and reused.

Reaction conditions for Runs 16 to 24

Rape seed oil (1.0 g), methanol (2.5, 5.0 or 10.0 fold excess) and catalyst ([emim][HSO₄]) (1.0 mol %, 2.5 mol % or 5.0 mol %) was placed in a glass tube with a magnetic stirrer flea. This was stirred at room temperature (20 °C) and the samples were analysed by GC after 2 hours, 4 hours and 144 hours (this was assumed to be long enough for equilibrium to be established) (See Tables 1 and 2; Reaction 1b; and Figure 1 for conditions). The two layers were also analysed by NMR (CDCl₃ for fat layer and (CD₃OD for methanol layer). The yield was determined by comparing the integration of the -CH₂- group in the glyceride with the OCH₃ group in the methyl ester of methyl oleate (bio-diesel).

Bio-diesel in accordance with European and American regulations, must be composed of 95.6% fatty acid methyl (or ethyl) ethers. Using the ionic liquid process of the present invention, 5 mol % catalyst and 10 fold excess of methanol are required to produce a bio-diesel that meets this specification for the acid ionic liquid catalyst.

For the acid catalysed transesterification of animal fat with methanol, higher reaction temperatures are needed (typically 90 to 160 °C). The transesterification can be carried out with an acidic or basic ionic liquid, with the acidic ionic liquids giving better results.

CLAIMS

1. A method of obtaining Bio-diesel comprising the step of esterifying fatty acids derived from plant or animal in the presence of a stable ionic liquid wherein the ionic liquid is both a solvent and a catalyst.
2. A method according to Claim 1 wherein the ionic liquid is acidic or basic.
3. A method according to Claim 1 or 2, wherein the ionic liquid comprises a basic cation and a neutral anion, or a neutral cation and a basic anion, or both a basic cation and a basic anion.
4. A method according to Claim 1 or 2, wherein the ionic liquid comprises an acidic cation and a neutral anion, or a neutral cation and an acidic anion, or both an acidic cation and an acidic anion.
5. A method according to Claim 3, wherein the basic cation has the formula:

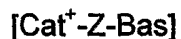

wherein: Cat^+ is a cationic species comprising or consisting of ammonium, phosphonium, pyrazolium, DBU or DBN;

Z is a covalent bond joining Cat^+ and Bas or 1, 2 or 3 aliphatic linking groups each containing 1 to 10 carbon atoms and each optionally one, two or three oxygen atoms; and

Bas is a basic moiety.

6. A method according to Claim 5, wherein Bas comprises at least one nitrogen, phosphorus, sulphur, oxygen or boron atom.

7. A method according to Claim 6, wherein Bas comprises at least one primary, secondary or tertiary amino group.
8. A method according to Claim 5 or Claim 6, wherein Bas is selected from $-N(R_1)(R_2)$, and $-P(R_1)(R_2)$; and wherein R_1 and R_2 can be the same or different and are each selected from hydrogen, linear or branched alkyl, cycloalkyl, aryl and substituted aryl.
9. A method according to Claim 8, wherein R_1 and R_2 are each selected from hydrogen, methyl, ethyl, *isopropyl*, butyl, *sec-butyl*, *isobutyl*, pentyl, hexyl, cyclohexyl, benzyl and phenyl.
10. A method according to Claim 8 or Claim 9, wherein Bas is selected from $-N(CH_3)_2$ and $-N(CH(CH_3)_2)_2$.
11. A method according to any one of Claims 5 to 10, wherein Z is selected from linear or branched C_1 to C_{18} alkanediyl, substituted alkanediyl, dialkanylether and dialkanylketone.
12. A method according to Claim 11, wherein Z is selected from $-(CH_2-CH_2)-$, $-(CH_2-CH_2-CH_2)-$, $-(CH_2-CH_2-CH_2-CH_2)-$, $-(CH_2-CH_2-CH_2-CH_2-CH_2)-$, $-(CH_2-CH_2-O-CH_2-CH_2)-$ and $-(CH_2-CH_2-O-CH_2-CH_2-CH_2)-$.
13. A method according to Claim 5, wherein $Cat^+-Z-Bas$ is selected from:



wherein: Bas and Z are as defined above; and

R^b , R^c , and R^d can be the same or different, and are each independently selected from hydrogen, a C_1 to C_{40} , straight chain or branched alkyl group, a C_3 to C_8 cycloalkyl group, or a C_6 to C_{10} aryl group, wherein said alkyl, cycloalkyl or

aryl groups are unsubstituted or may be substituted by one to three groups selected from: C₁ to C₆ alkoxy, C₆ to C₁₀ aryl, CN, OH, NO₂, C₇ to C₃₀ aralkyl and C₇ to C₃₀ alkaryl.

14. A method according to Claim 5, wherein Cat⁺-Z-Bas is selected from:

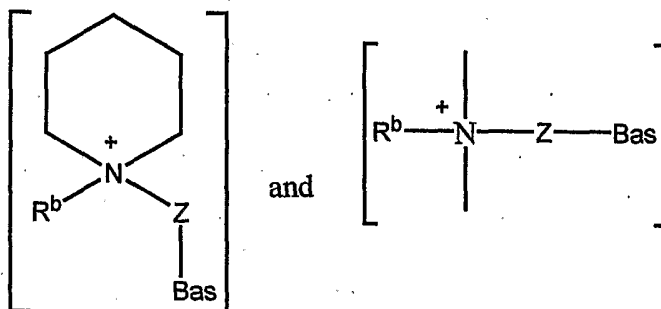

wherein: Z, Bas and R^b is as defined above.

15. A method according to Claim 14, wherein Cat⁺-Z-Bas is selected from:

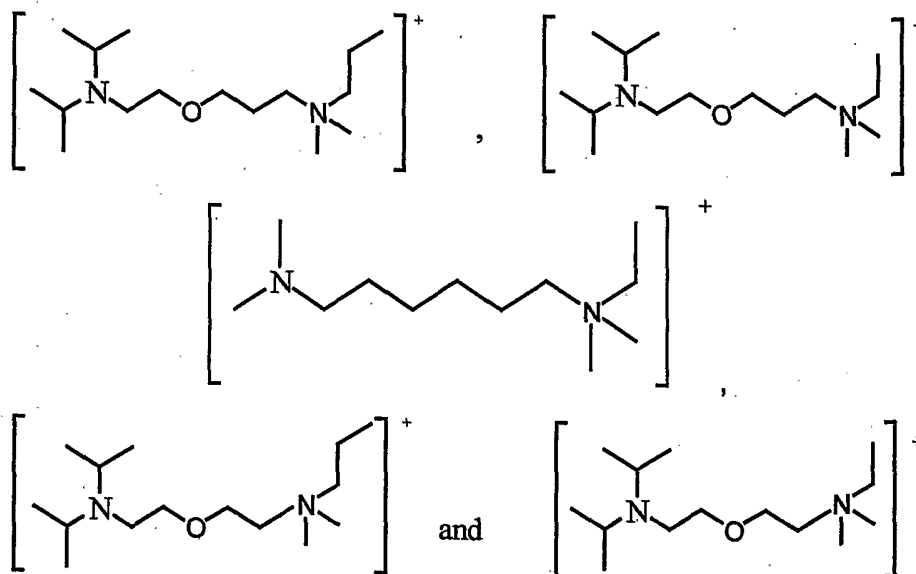

16. A method according to Claim 5, wherein Cat⁺ comprises or consists of 1,3,5-trialkylpyrazolium, 1,2-dialkylpyrazolium, and 1,2,3,5-tetraalkylpyrazolium.

17. A method according to Claim 16, wherein $\text{Cat}^+\text{-Z-Bas}$ is selected from:

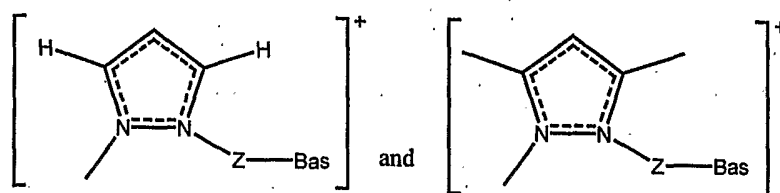

18. A method according to Claim 5, wherein $\text{Cat}^+\text{-Z-Bas}$ is selected from:

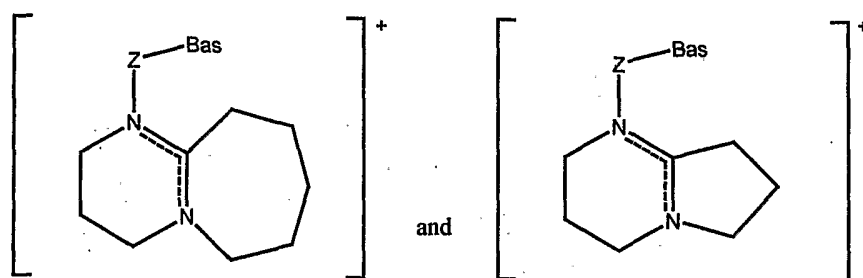

19. A method according to Claim 5, wherein $\text{Cat}^+\text{-Z-Bas}$ is:

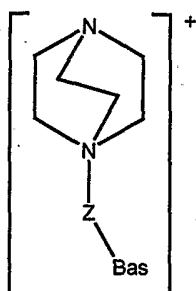

wherein: Bas, Z and R^b are as defined above.

20. A method according to Claim 3, wherein the basic anion has the formula $[\text{X}_b]^-$, and may be selected from $[\text{F}]^-$, $[\text{OH}]^-$, $[\text{OR}]^-$, $[\text{R-CO}_2]^-$, $[\text{PO}_4]^{3-}$ and $[\text{SO}_4]^{2-}$, wherein R is C_1 to C_6 alkyl.

21. A method according to Claim 20, wherein $[\text{X}_b]^-$ is $[\text{OH}]^-$.

22. A method according to Claim 4, wherein the acidic cation has the formula:

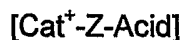

wherein: Cat^+ is a cationic species;

Z is a covalent bond joining Cat^+ and Acid containing 1 to 10 carbon atoms and each optionally one, two or three oxygen atoms; and

Acid is an acidic moiety.

23. A method according to Claim 22, wherein acid is selected from $-\text{SO}_3\text{H}$, $-\text{CO}_2\text{H}$, $-\text{SO}_3\text{-PH-R}$, $-\text{SO}_3\text{R}$, $\text{RPO}(\text{OH})_2$ and $\text{R}_2\text{PO}(\text{OH})$, where R is C_1 to C_6 alkyl or C_1 to C_6 aryl

24. A method according to Claim 22, wherein $[\text{Cat}^+]$ comprises or consists of a heterocyclic ring structure selected from imidazolium, pyridinium, pyrazolium, thiazolium, isothiazolinium, azathiazolium, oxothiazolium, oxazinium, oxazolium, oxaborolium, dithiazolium, triazolium, selenozolium, oxaphospholium, pyrrolium, borolium, furanium, thiophenium, phospholium, pentazolium, indolium, indolinium, oxazolium, isooxazolium, isotriazolium, tetrazolium, benzofuranium, dibenzofuranium, benzothiophenium, dibenzothiophenium, thiadiazolium, pyrimidinium, pyrazinium, pyridazinium, piperazinium, piperidinium, morpholinium, pyranium, annolinium, phthalazinium, quinazolinium, quinazalinium, quinolinium, isoquinolinium, thazinium, oxazinium, azaannulenium and pyrrolidinium.

25. A method according to Claim 24, wherein $[\text{Cat}^+]$ comprises or consists of a heterocyclic ring structure selected from pyrazolium, isothiazolinium, tetrazolium, piperidinium, morpholinium and pyrrolidinium.

26. A method according to Claim 25, wherein Cat⁺-Z-Acid is selected from:-

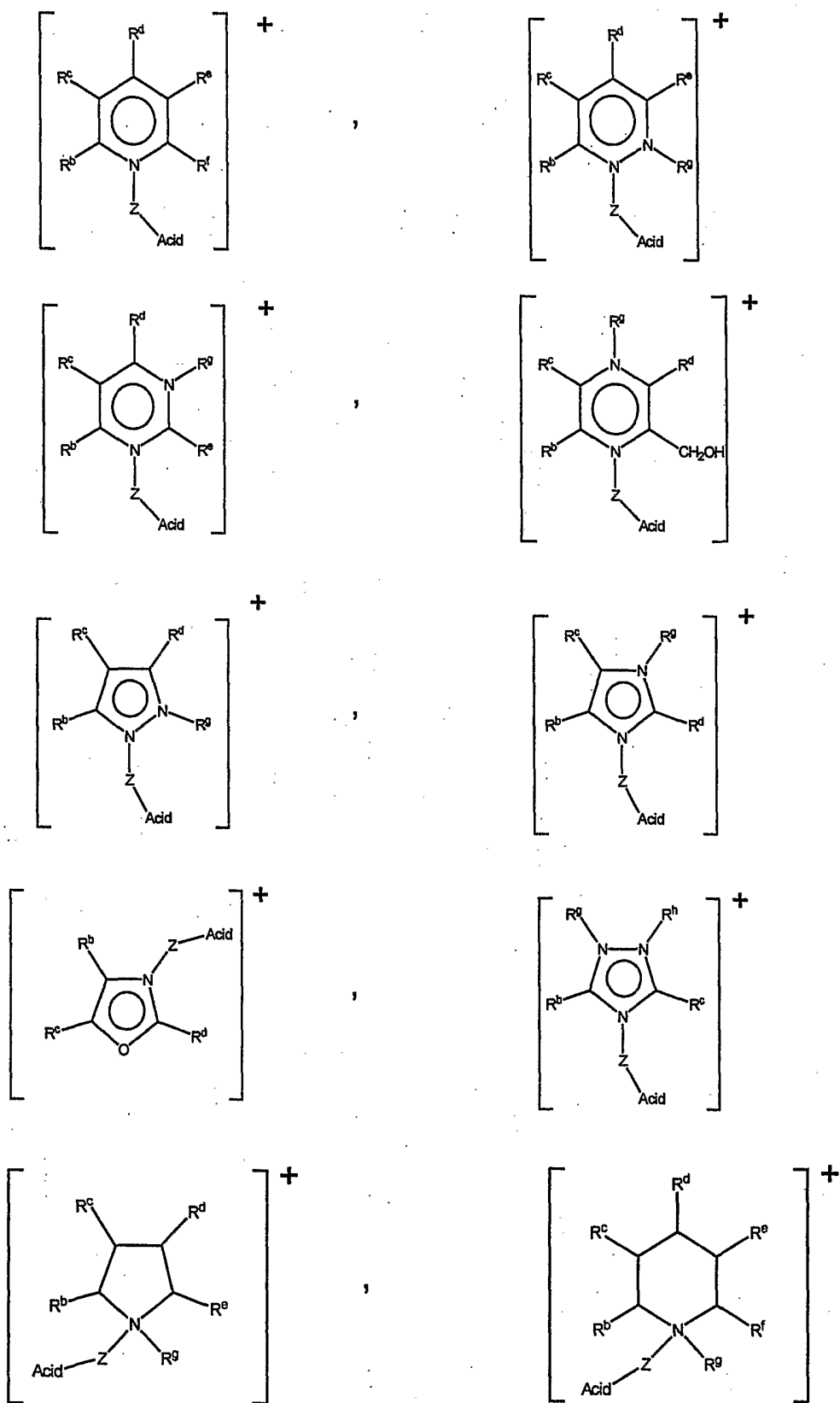

and

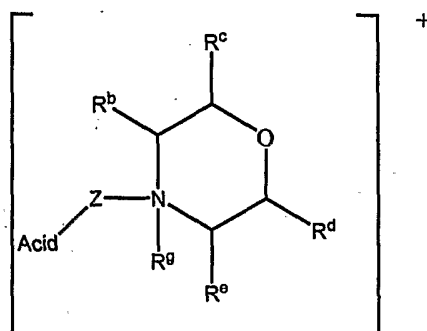

wherein: Acid and Z are as defined above; and

R^b, R^c, R^d, R^e, R^f, R^g and R^h can be the same or different, and are each independently selected from hydrogen, a C₁ to C₄₀, straight chain or branched alkyl group, a C₃ to C₈ cycloalkyl group, or a C₆ to C₁₀ aryl group, wherein said alkyl, cycloalkyl or aryl groups are unsubstituted or may be substituted by one to three groups selected from: C₁ to C₆ alkoxy, C₆ to C₁₀ aryl, CN, OH, NO₂, C₇ to C₃₀ aralkyl and C₇ to C₃₀ alkaryl, or any two of R^b, R^c, R^d, R^e and R^f attached to adjacent carbon atoms form a methylene chain -(CH₂)_q- wherein q is from 8 to 20.

27. A method according to Claim 26, wherein Cat⁺-Z-Acid is:

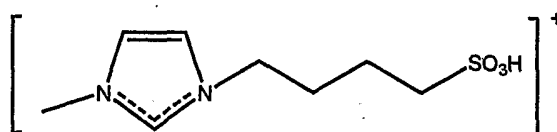

28. A method according to Claim 4, wherein the acidic anion has the formula [X_a]⁻, and is selected from [HSO₄]⁻, [H₂PO₄]⁻, [HPO₄]²⁻, [HCl₂]⁻ and [HX₂]⁻, wherein X = F, Cl, Br or I.

29. A method according to Claim 28, wherein [X_a]⁻ is selected from [HF₂]⁻, [HSO₄]⁻ and [H₂PO₄]⁻.

30. A method according to Claim 3, wherein the neutral cation comprises or consists of ammonium, phosphonium, pyrazolium, DBU or DBN.

31. A method according to Claim 30, wherein the neutral cation is selected from:



wherein: R^a , R^b , R^c , and R^d can be the same or different, and are each independently selected from hydrogen, a C_1 to C_{40} , straight chain or branched alkyl group, a C_3 to C_8 cycloalkyl group, or a C_6 to C_{10} aryl group, wherein said alkyl, cycloalkyl or aryl groups are unsubstituted or may be substituted by one to three groups selected from: C_1 to C_6 alkoxy, C_6 to C_{10} aryl, CN, OH, NO_2 , C_7 to C_{30} aralkyl and C_7 to C_{30} alkaryl.

32. A method according to Claim 31, wherein the neutral cation is selected from:

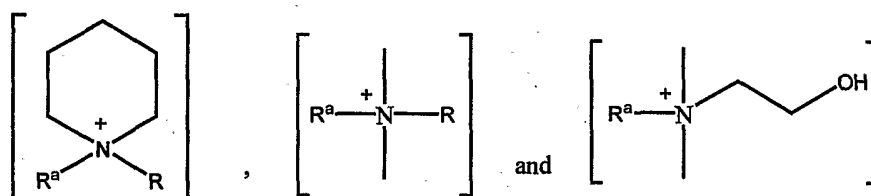

wherein: R^a is as defined above.

33. A method according to Claim 31, wherein the neutral cation is selected from:

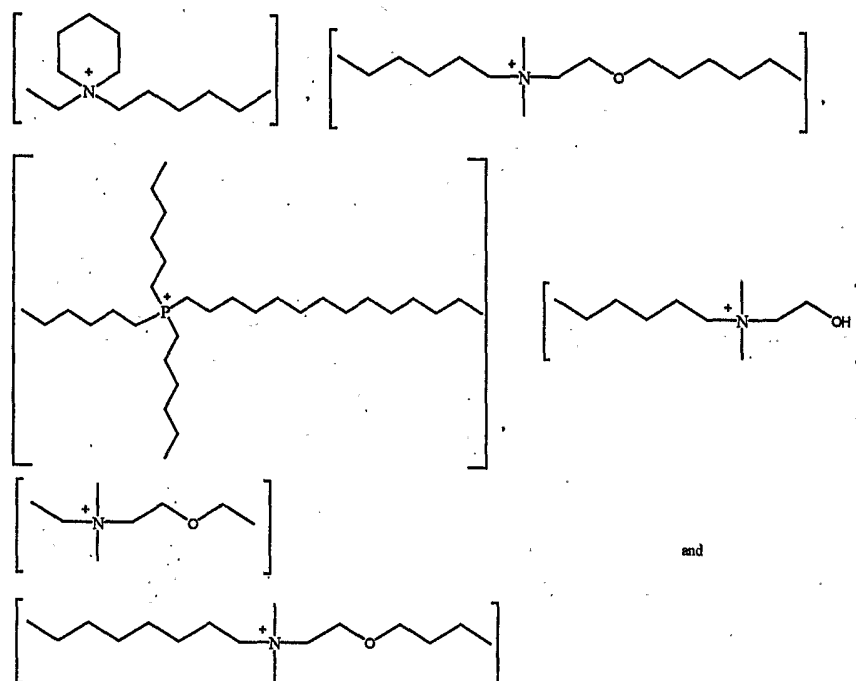

34. A method according to Claim 31, wherein the neutral cation comprises or consists of 1, 3, 5-trialkyl pyrazolium, 1, 2-dialkylpyrazolium, or 1, 2, 3, 5-tetraalkylpyrazolium.

35. A method according to Claim 34, wherein the neutral cation is selected from:

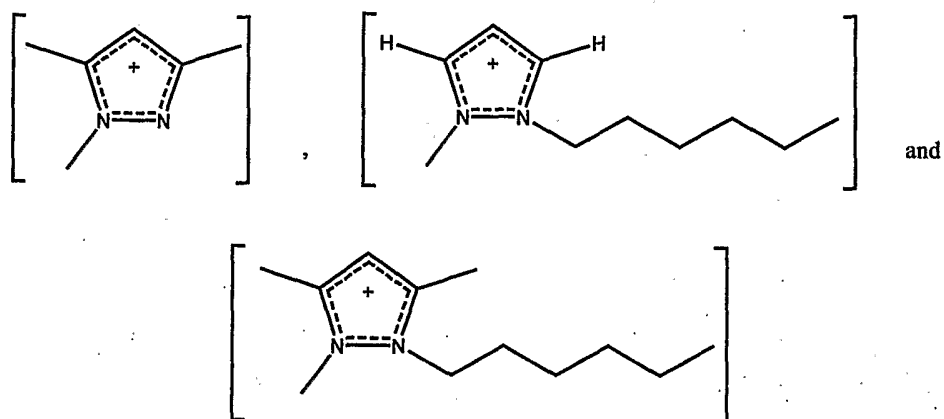

36. A method according to Claim 31, wherein the neutral cation is selected from:

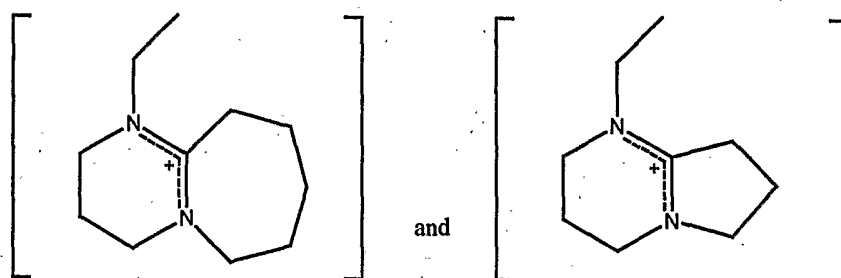

37. A method according to Claim 4, wherein the neutral cation comprises or consists of a heterocyclic ring structure selected from imidazolium, pyridinium, pyrazolium, thiazolium, isothiazolinium, azathiazolium, oxothiazolium, oxazinium, oxazolium, oxaborolium, dithiazolium, triazolium, selenozolium, oxaphospholium, pyrrolium, borolium, furanium, thiophenium, phospholium, pentazolium, indolium, indolinium, oxazolium, isooxazolium, isotriazolium, tetrazolium, benzofuranium, dibenzofuranium, benzothiophenium, dibenzothiophenium, thiadiazolium, pyrimidinium, pyrazinium, pyridazinium, piperazinium, piperidinium, morpholinium, pyranium, annolinium, phthalazinium, quinazolinium, quinazalinium, quinolinium, isoquinolinium, thazinium, oxazinium, azaannulenium and pyrrolidinium.

38. A method according to Claim 36, wherein the neutral cation comprises or consists of a heterocyclic ring structure selected from pyridinium, pyrazolium, thiazolium, pyrimidinium, piperazinium, piperidinium, morpholinium, quinolinium, isoquinolinium and pyrrolidinium.

39. A method according to Claim 38, wherein the neutral cation is selected from:-

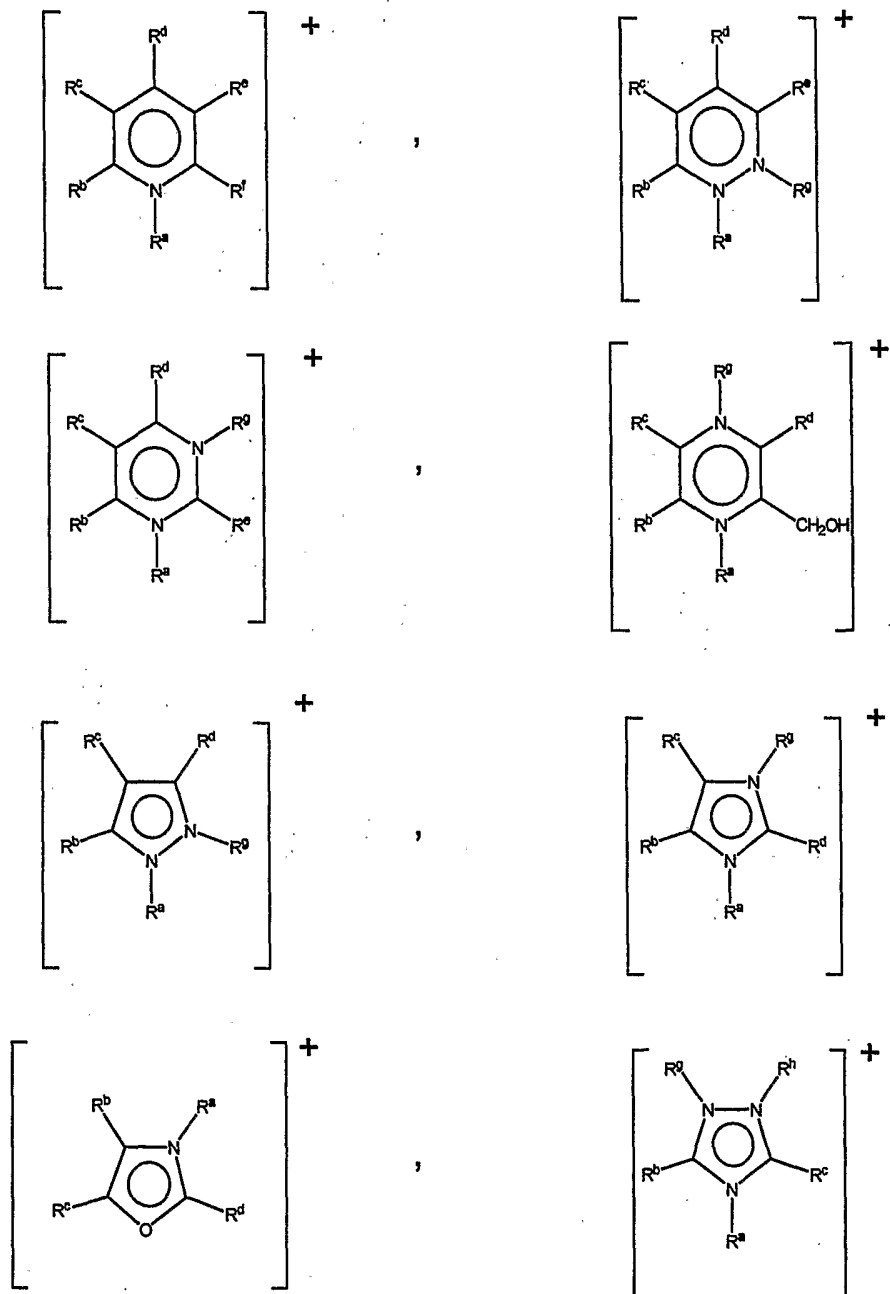

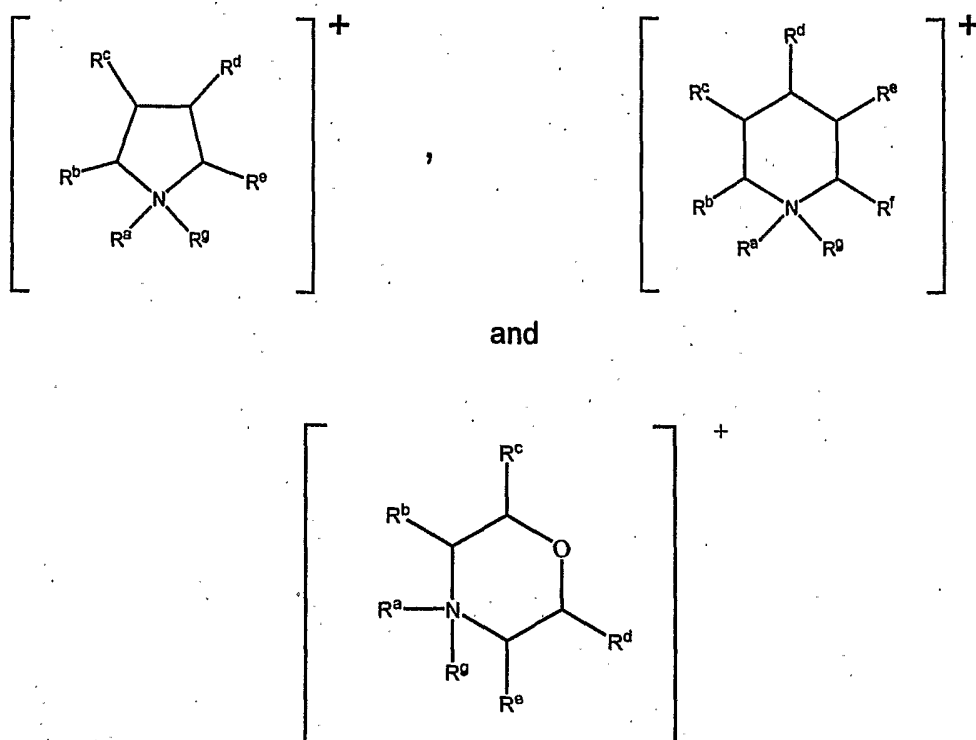

wherein: R^a , R^b , R^c , R^d , R^e , R^f , R^g and R^h can be the same or different, and are each independently selected from hydrogen, a C_1 to C_{40} , straight chain or branched alkyl group, a C_3 to C_8 cycloalkyl group, or a C_6 to C_{10} aryl group, wherein said alkyl, cycloalkyl or aryl groups are unsubstituted or may be substituted by one to three groups selected from: C_1 to C_6 alkoxy, C_6 to C_{10} aryl, CN, OH, NO_2 , C_7 to C_{30} aralkyl and C_7 to C_{30} alkaryl, or any two of R^b , R^c , R^d , R^e and R^f attached to adjacent carbon atoms form a methylene chain $-(CH_2)_q-$ wherein q is from 8 to 20.

40. A method according to Claim 3 or Claim 4, wherein the neutral anion is a sulfonate, phosphinate, triflamide (amide), triflate, dicyanamide, oxide (phenoxide) or halide anionic species.

41. A method according to Claim 40, wherein the neutral anion is selected from $[NTf_2]^-$, $[OTf]^-$, $[R-SO_3]^-$, $[R_2PO_2]^-$, $[Cl]^-$, $[Br]^-$ and $[I]^-$; wherein R is C_1 to C_6 alkyl, or C_1 to C_6 aryl.

42. A method according to Claim 41, wherein the neutral anion is selected from $[\text{Me-SO}_3^-]$, $[\text{Ph-SO}_3^-]$ and $[\text{Me-Ph-SO}_3^-]$.
43. A method according to any one of the preceding Claims, wherein the plant fatty acid is derived from rape seed oil or prioline.
45. A method according to any one of the preceding claims, wherein the bio-diesel product and the ionic liquid are immiscible.
46. A method according to any one of the preceding claims, wherein the bio-diesel product is obtained from the reactants by phase separation.
47. A method according to any one of the preceding claims, wherein the ionic liquid is recycled.
48. Use of bio-diesel obtained by the method of any one of Claims 1 to 47 in blending with a petroleum compound.
49. Use according to Claim 48, wherein the petroleum compound is diesel.

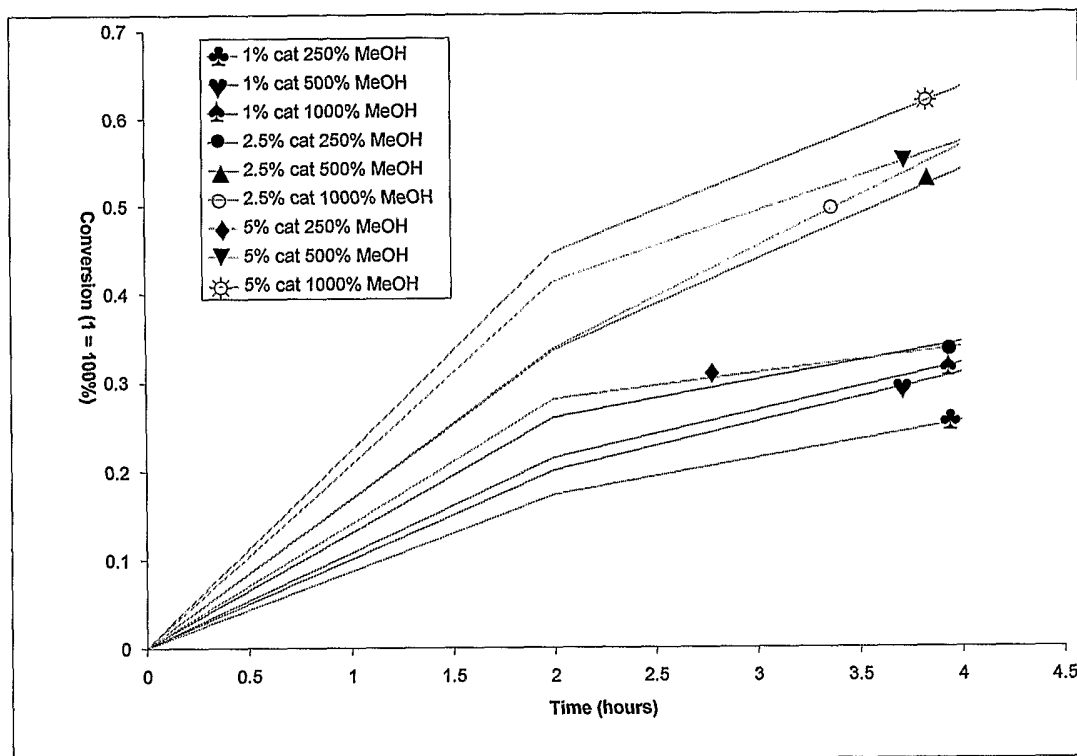

Figure 1

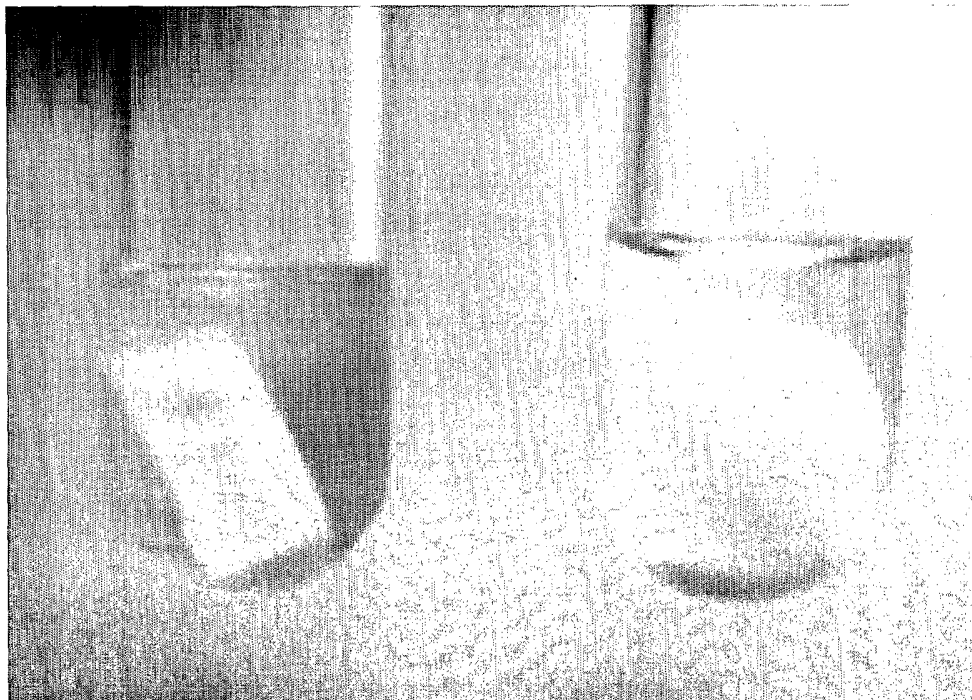

Figure 2

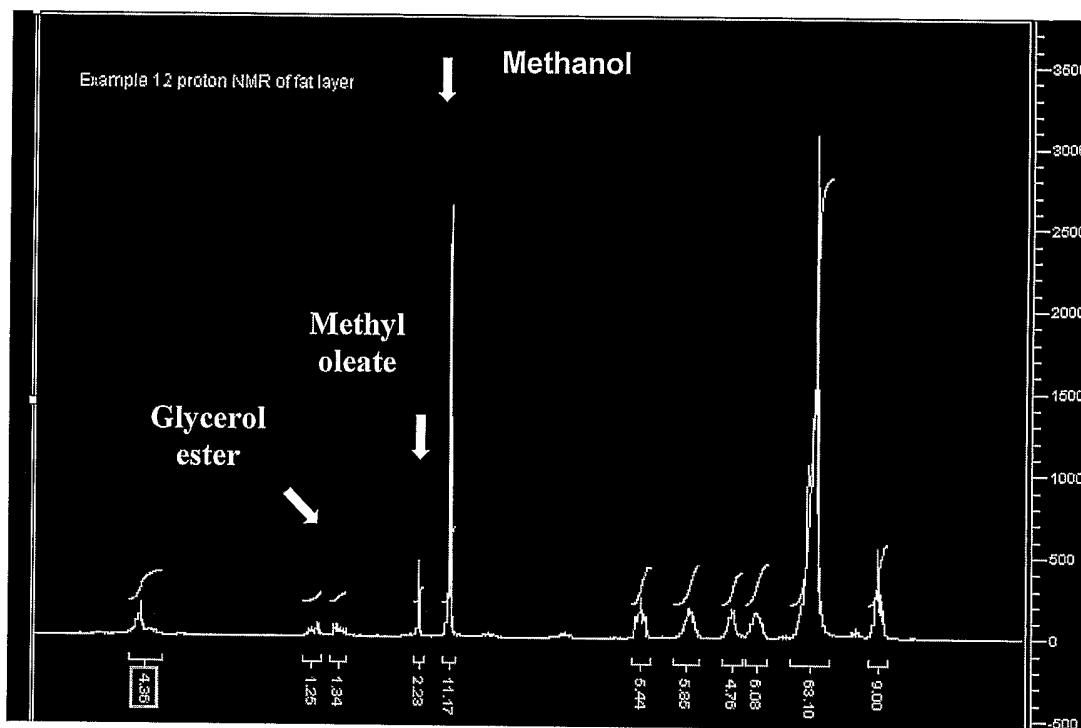

Figure 3

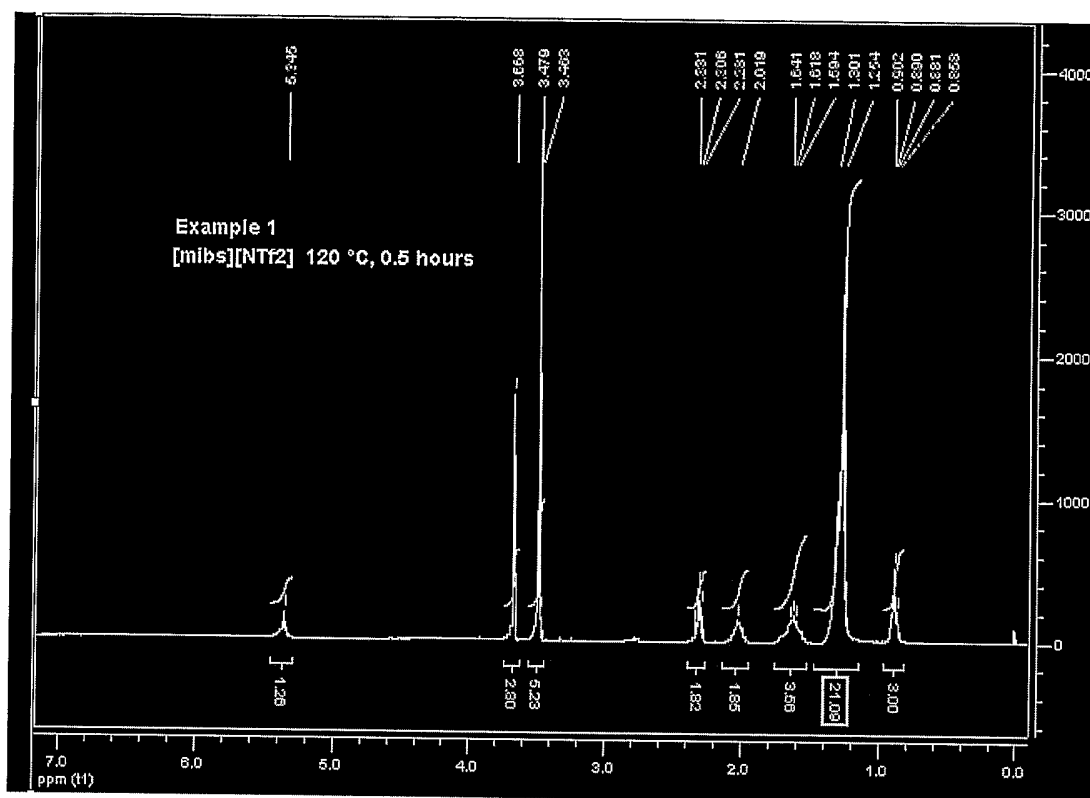

Figure 4

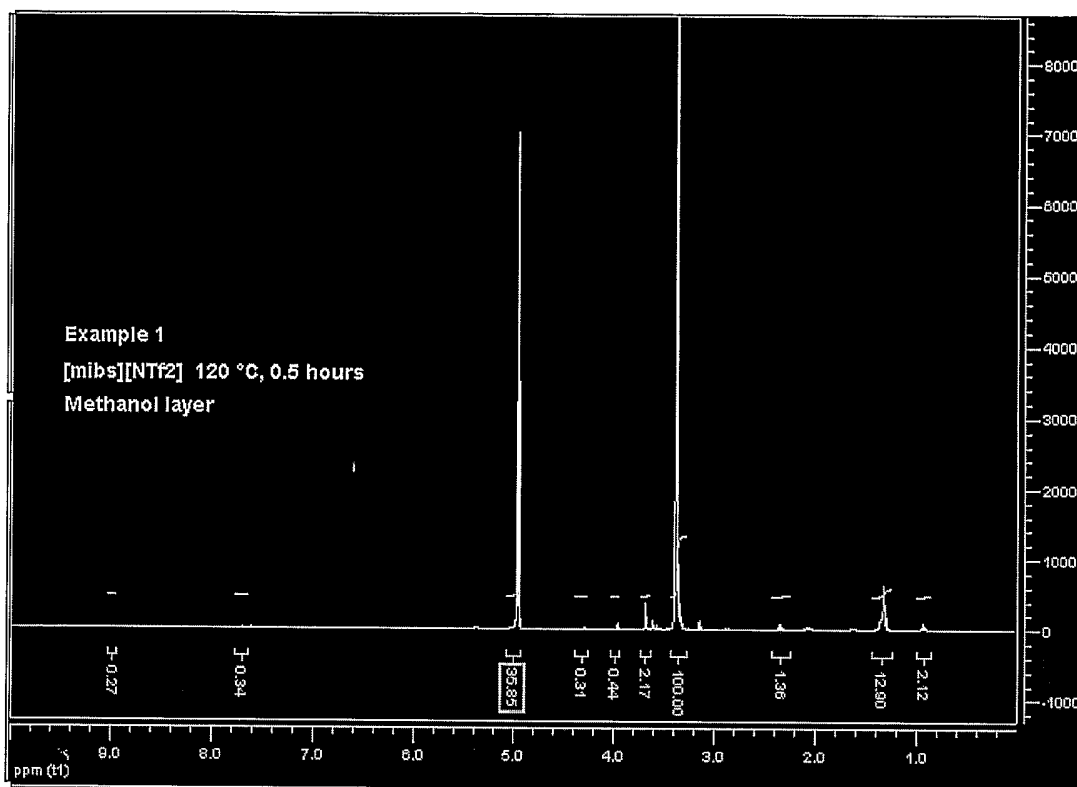

Figure 5

INTERNATIONAL SEARCH REPORT

International application No
PCT/GB2006/000682

A. CLASSIFICATION OF SUBJECT MATTER
INV. B01J31/02 C07C67/03 C10L1/00

According to International Patent Classification (IPC) or to both national classification and IPC

B. FIELDS SEARCHED

Minimum documentation searched (classification system followed by classification symbols)
B01J C07C C10L

Documentation searched other than minimum documentation to the extent that such documents are included in the fields searched

Electronic data base consulted during the international search (name of data base and, where practical, search terms used)

EPO-Internal, WPI Data

C. DOCUMENTS CONSIDERED TO BE RELEVANT

Category*	Citation of document, with indication, where appropriate, of the relevant passages	Relevant to claim No.
X	J. FROAGA-DUBREUIL, K. BOURAHLA, M. RAHMOUNI, JP. BAZUREAU, J. HAMELIN: "Catalysed esterifications in room temperature ionic liquids with acidic counteranion as recyclable reaction media" CATALYSIS COMMUNICATIONS, vol. 3, 2002, pages 185-190, XP002386188 cited in the application page 186 - page 188 table 1 figure 2	1-47

Further documents are listed in the continuation of Box C.

See patent family annex.

* Special categories of cited documents:

- *A* document defining the general state of the art which is not considered to be of particular relevance
- *E* earlier document but published on or after the international filing date
- *L* document which may throw doubts on priority claim(s) or which is cited to establish the publication date of another citation or other special reason (as specified)
- *O* document referring to an oral disclosure, use, exhibition or other means
- *P* document published prior to the international filing date but later than the priority date claimed

- *T* later document published after the international filing date or priority date and not in conflict with the application but cited to understand the principle or theory underlying the invention
- *X* document of particular relevance; the claimed invention cannot be considered novel or cannot be considered to involve an inventive step when the document is taken alone
- *Y* document of particular relevance; the claimed invention cannot be considered to involve an inventive step when the document is combined with one or more other such documents, such combination being obvious to a person skilled in the art.
- *&* document member of the same patent family

Date of the actual completion of the international search

29 June 2006

Date of mailing of the international search report

13/07/2006

Name and mailing address of the ISA/
European Patent Office, P.B. 5618 Patentlaan 2
NL - 2280 HV Rijswijk
Tel. (+31-70) 340-2040, Tx. 31 651 epo nl,
Fax: (+31-70) 340-3016

Authorized officer

Bernet, O

INTERNATIONAL SEARCH REPORT

International application No

PCT/GB2006/000682

C(Continuation). DOCUMENTS CONSIDERED TO BE RELEVANT		
Category*	Citation of document, with indication, where appropriate, of the relevant passages	Relevant to claim No.
X	DEMIRBAS A: "Biodiesel fuels from vegetable oils via catalytic and non-catalytic supercritical alcohol transesterifications and other methods: a survey" ENERGY CONVERSION AND MANAGEMENT, ELSEVIER SCIENCE PUBLISHERS, OXFORD, GB, vol. 44, no. 13, August 2003 (2003-08), pages 2093-2109, XP004414476 ISSN: 0196-8904 page 2098, paragraph 2.2	48, 49
P, X	CN 1 696 248 A (INST OF PROCEDURE, C.A.S) 16 November 2005 (2005-11-16) EPO Abstract	1-49
A	WELTON T: "Ionic liquids in catalysis" COORDINATION CHEMISTRY REVIEWS, ELSEVIER SCIENCE, AMSTERDAM, NL, vol. 248, no. 21-24, December 2004 (2004-12), pages 2459-2477, XP004917440 ISSN: 0010-8545 the whole document	1-49
A	ABREU ET AL: "New multi-phase catalytic systems based on tin compounds active for vegetable oil transesterification reaction" JOURNAL OF MOLECULAR CATALYSIS. A, CHEMICAL, ELSEVIER, AMSTERDAM, NL, vol. 227, no. 1-2, 1 March 2005 (2005-03-01), pages 263-267, XP005004491 ISSN: 1381-1169 the whole document	1-49
A	D. ZHAO, M. WU, Y. KOU, E. MIN: "Ionic liquids: applications in catalysis" CATALYSIS TODAY, vol. 74, 2002, pages 157-189, XP002386189 the whole document	1-49
A	T. WELTON: "Room-Temperature Ionic Liquids. Solvents for Synthesis and Catalysis" CHEMICAL REVIEWS, vol. 99, 1999, pages 2071-2083, XP002386190 the whole document	1-49
	----- -/-- -----	

INTERNATIONAL SEARCH REPORT

International application No

PCT/GB2006/000682

C(Continuation). DOCUMENTS CONSIDERED TO BE RELEVANT

Category*	Citation of document, with indication, where appropriate, of the relevant passages	Relevant to claim No.
A	DEMIRBAS A: "Biodiesel from vegetable oils via transesterification in supercritical methanol" ENERGY CONVERSION AND MANAGEMENT, ELSEVIER SCIENCE PUBLISHERS, OXFORD, GB, vol. 43, no. 17, November 2002 (2002-11), pages 2349-2356, XP004370304 ISSN: 0196-8904 the whole document	1-49
A	GRABOSKI M S ET AL: "Combustion of fat and vegetable oil derived fuels in diesel engines" PROGRESS IN ENERGY AND COMBUSTION SCIENCE, ELSEVIER SCIENCE PUBLISHERS, AMSTERDAM, NL, vol. 24, no. 2, 1998, pages 125-164, XP004116553 ISSN: 0360-1285 the whole document	1-49

INTERNATIONAL SEARCH REPORT

Information on patent family members

International application No

PCT/GB2006/000682

Patent document cited in search report	Publication date	Patent family member(s)	Publication date
CN 1696248	A	NONE	