

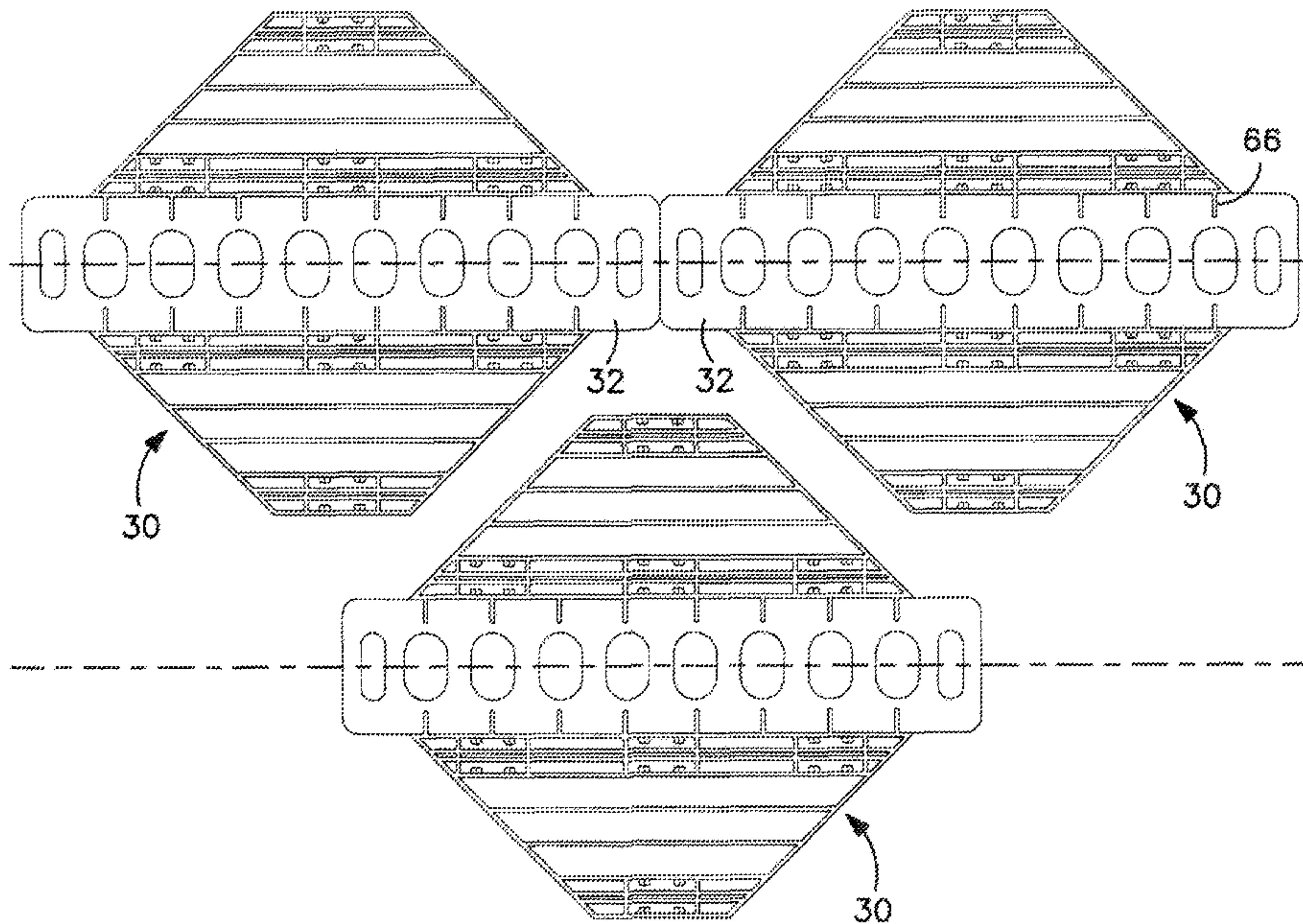

(86) Date de dépôt PCT/PCT Filing Date: 2009/09/29  
 (87) Date publication PCT/PCT Publication Date: 2010/04/01  
 (45) Date de délivrance/Issue Date: 2017/07/04  
 (85) Entrée phase nationale/National Entry: 2011/03/29  
 (86) N° demande PCT/PCT Application No.: US 2009/058728  
 (87) N° publication PCT/PCT Publication No.: 2010/037084  
 (30) Priorité/Priority: 2008/09/29 (US12/240,269)

(51) Cl.Int./Int.Cl. *E04F 15/22* (2006.01),  
*E04B 5/43* (2006.01)  
 (72) Inventeurs/Inventors:  
RANDJELOVIC, ERLIN A., US;  
JENKINS, MARK, US;  
HANEY, THAYNE, US  
 (73) Propriétaire/Owner:  
CONNOR SPORT COURT INTERNATIONAL, LLC, US  
 (74) Agent: NORTON ROSE FULBRIGHT CANADA  
LLP/S.E.N.C.R.L., S.R.L.

(54) Titre : ENSEMBLES SOUS-PLANCHERS POUR SYSTEMES DE PLANCHER DE SPORT  
 (54) Title: SUB-FLOOR ASSEMBLIES FOR SPORTS FLOORING SYSTEMS



(57) **Abrégé/Abstract:**

A sub-floor assembly for a sports flooring system includes a plurality of sub-floor panel components each formed of a plastic material and each having a formed channel wherein the formed channels of the plurality of sub-floor panel components are linearly aligned. A first strip of anchoring material is disposed within the linearly aligned formed channels of the plurality of sub-floor panel components and is used to attach a plurality of flooring strips to the sub-floor panel components.

(12) INTERNATIONAL APPLICATION PUBLISHED UNDER THE PATENT COOPERATION TREATY (PCT)

(19) World Intellectual Property Organization  
International Bureau(43) International Publication Date  
1 April 2010 (01.04.2010)(10) International Publication Number  
**WO 2010/037084 A1**(51) International Patent Classification:  
*E04F 15/22* (2006.01)**HANEY, Thayne** [US/US]; 1463 South Evalin Circle,  
Syracuse, Utah 84075 (US).(21) International Application Number:  
PCT/US2009/058728(74) Agents: **JAROSIK, Gary, R.** et al.; Greenberg Traurig,  
LLP, 77 W. Wacker Drive, Suite 3100, Chicago, Illinois  
60601-1732 (US).(22) International Filing Date:  
29 September 2009 (29.09.2009)(81) Designated States (*unless otherwise indicated, for every  
kind of national protection available*): AE, AG, AL, AM,  
AO, AT, AU, AZ, BA, BB, BG, BH, BR, BW, BY, BZ,  
CA, CH, CL, CN, CO, CR, CU, CZ, DE, DK, DM, DO,  
DZ, EC, EE, EG, ES, FI, GB, GD, GE, GH, GM, GT,  
HN, HR, HU, ID, IL, IN, IS, JP, KE, KG, KM, KN, KP,  
KR, KZ, LA, LC, LK, LR, LS, LT, LU, LY, MA, MD,  
ME, MG, MK, MN, MW, MX, MY, MZ, NA, NG, NI,  
NO, NZ, OM, PE, PG, PH, PL, PT, RO, RS, RU, SC, SD,  
SE, SG, SK, SL, SM, ST, SV, SY, TJ, TM, TN, TR, TT,  
TZ, UA, UG, US, UZ, VC, VN, ZA, ZM, ZW.

(25) Filing Language: English

(26) Publication Language: English

(30) Priority Data:  
12/240,269 29 September 2008 (29.09.2008) US(71) Applicant (*for all designated States except US*): **CON-  
NOR SPORT COURT INTERNATIONAL, INC.** [US/  
US]; 939 South 700 West, Salt Lake City, Utah 84104  
(US).

(72) Inventors; and

(75) Inventors/Applicants (*for US only*): **RANDJELOVIC,  
Erlin, A.** [US/US]; 309 Kohon Road, Crystal Falls,  
Michigan 49920 (US). **JENKINS, Mark** [US/US]; 6425  
West 3270 South, West Valley City, Utah 84128 (US).(84) Designated States (*unless otherwise indicated, for every  
kind of regional protection available*): ARIPO (BW, GH,  
GM, KE, LS, MW, MZ, NA, SD, SL, SZ, TZ, UG, ZM,  
ZW), Eurasian (AM, AZ, BY, KG, KZ, MD, RU, TJ,  
TM), European (AT, BE, BG, CH, CY, CZ, DE, DK, EE,

[Continued on next page]

(54) Title: SUB-FLOOR ASSEMBLIES FOR SPORTS FLOORING SYSTEMS

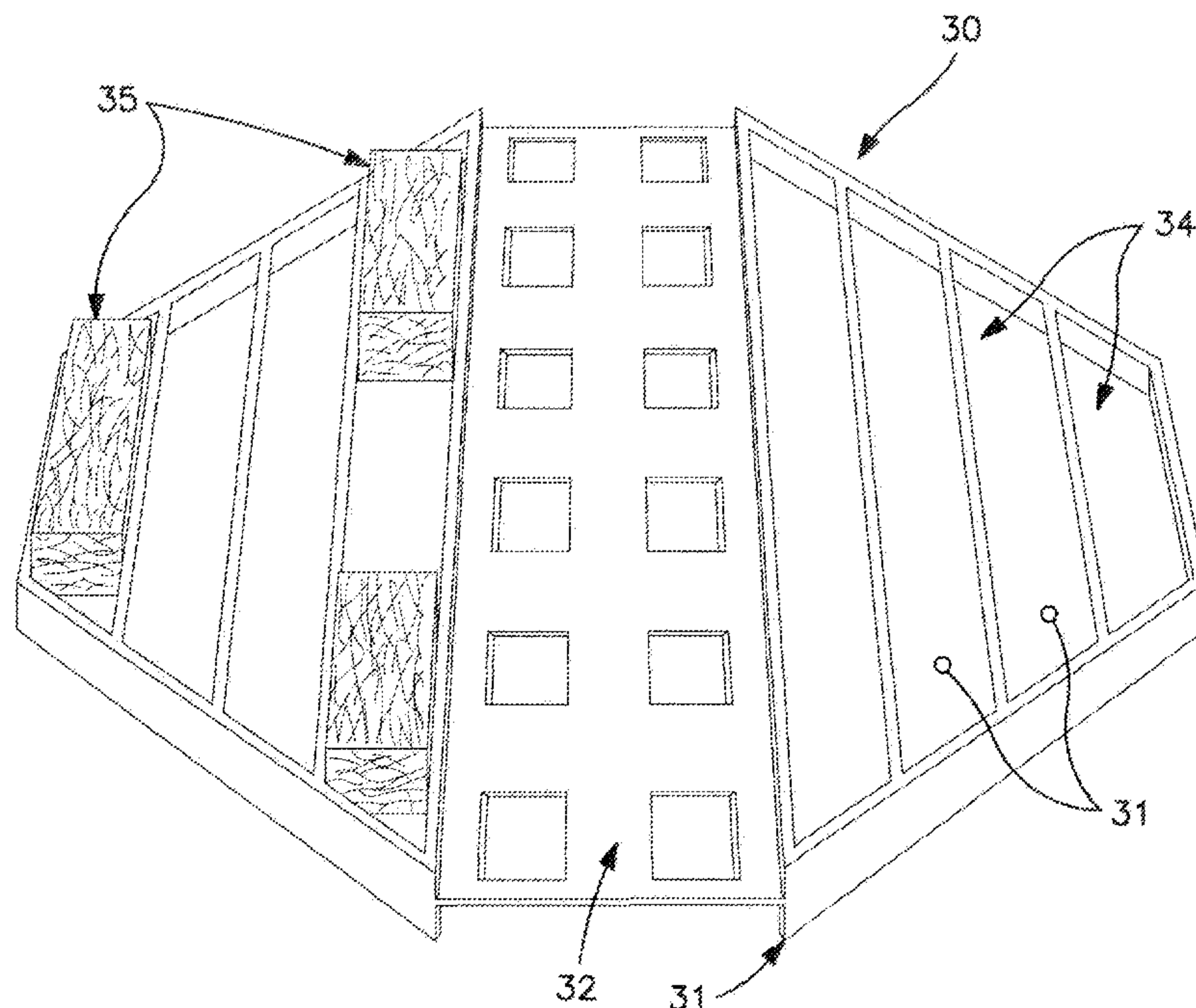

FIG. 2

(57) Abstract: A sub-floor assembly for a sports flooring system includes a plurality of sub-floor panel components each formed of a plastic material and each having a formed channel wherein the formed channels of the plurality of sub-floor panel components are linearly aligned. A first strip of anchoring material is disposed within the linearly aligned formed channels of the plurality of sub-floor panel components and is used to attach a plurality of flooring strips to the sub-floor panel components.

**WO 2010/037084 A1** 

---

ES, FI, FR, GB, GR, HR, HU, IE, IS, IT, LT, LU, LV, **Published:**  
MC, MK, MT, NL, NO, PL, PT, RO, SE, SI, SK, SM, — *with international search report (Art. 21(3))*  
TR), OAPI (BF, BJ, CF, CG, CI, CM, GA, GN, GQ, GW,  
ML, MR, NE, SN, TD, TG).

## SUB-FLOOR ASSEMBLIES FOR SPORTS FLOORING SYSTEMS

## TECHNICAL FIELD

The following generally relates to sub-floor assemblies suitable for applications in multiple use facilities and in the construction of sports flooring and, more particularly, relates to a sub-floor assembly including a molded synthetic material component.

## BACKGROUND

Sports flooring systems offer various designs including rigid construction providing little or no resilience, as well as highly resilient shock absorbing cushioned floors. Sports flooring systems include the option of anchorage methods to attach to a supporting substrate, which is most commonly concrete. Many sports flooring system designs also float freely with no anchorage attachment to the supporting substrate.

Examples of anchored sports flooring systems that provide little or no resiliency are exemplified in designs disclosed in U.S. Pat. No. 3,518,800 to Tank et al. and U.S. Pat. No. 3,566,569 to Coke et al. The Tank patent discloses a construction method wherein a steel channel is anchored to the supporting substrate and specially manufactured metal clips are used to secure flooring boards to the steel channels. The Coke patent discloses a construction method wherein wooden nailing strips are anchored to the supporting substrate and flooring boards are attached to the nailing strips by stapling or nailing.

Designs disclosed in U.S. Pat No. 5,369,710 to Peterson et al. and U.S. Pat. No. 5,369,710 to Randjelovic et al. demonstrate widely used floating sports flooring system construction. The designs disclosed in both of these patents include resilient components resting on a supporting substrate which in turn supports a wooden sub-floor and flooring surface.

Sub-floor panels are also known to be manufactured of moldable material such as plastic or polyethylene. The design of such panels includes tongue and groove edges formed to interlock panels into a monolithic surface, which serves to support a flooring surface. Flooring material such as tongue and groove flooring is directly attached to the interlocking panels by means of mechanical fasteners such as staples or cleats. The underside of such panels can include cavity spaces in which resilient pads such as those previously described in the Peterson and Randjelovic patents are placed.

Another sub-floor assembly design is disclosed in U.S. Pat. No. 5,016,413 to Counihan et al. which includes a wooden panel sub-floor supported with resilient components. The design illustrated in the Counihan patent includes arranged plywood sub-floor panels and a means to restrain the flooring system by incorporating steel channels attached to the supporting substrate. U.S. Pat. No. 4,856,250 to Gronau et al. and U.S. Pat. No. 6,122,873 et al. to Randjelovic further demonstrate designs incorporating various wooden sub-floor and resilient components. These three referenced patents illustrate various methods to provide flooring systems with stability by means of substrate attachment while also providing resilient components for wanted shock absorbency.

These referenced patents and designs are examples of the known range of sub-floor constructions available and in use in the sports floor industry.

#### SUMMARY

To provide numerous advantages over known designs such as those described in the background section, disclosed hereinafter is an advanced sports flooring system sub-floor assembly. More particularly, the hereinafter disclosed sports flooring sub-floor assembly provides a sub-floor having a molded or extruded synthetic sub-floor component for placement over a sound substrate which, in turn, provides a base for attachment and/or support of a flooring surface. Since mechanical fasteners are not well suited for attachment into molded or extruded synthetic components, especially under conditions of changing temperatures and when constant flexing is expected as is typically desired in resilient sports flooring systems, the hereinafter described sub-floor assembly may further strategically incorporate elongated wooden nailing sections integrated with the molded or extruded synthetic panels which, in turn, may include designated underside cavities especially used for placement and housing of resilient components.

As will be appreciated, since the subject sub-floor assembly incorporates the use of synthetic materials, which may include recycled plastic materials, it has, among others, the advantage of being environmentally friendly, e.g., it reduces the use of forestry materials. In addition, it will be understood that the subject sub-floor assembly has the advantage of providing design flexibility, e.g., the formed sub-floor sections can be provided with a wide range of cavity designs that, in turn, allow for strategic placement of resilient components.

While the foregoing generally describes the subject sub-floor assembly and various advantages achieved thereby, a better understanding of the objects, advantages, features, properties, and relationships of the invention will be obtained from the following detailed description and accompanying drawings which set forth illustrative embodiments  
5 which are indicative of the various ways in which the principles of the invention may be employed.

#### BRIEF DESCRIPTION OF THE DRAWINGS

For a better understanding of the invention reference may be had to preferred  
10 embodiments shown in the following drawings in which:

FIG. 1 is a perspective top view of a first exemplary molded sub-floor panel section made according to the present invention;

FIG. 2 is a perspective bottom view of the molded sub-floor panel section illustrated in FIG. 1;

15 FIG. 3 is a top view of the molded sub-floor panel section illustrated in FIG. 1;

FIG. 4 is a cross-sectional view of the molded sub-floor panel illustrated in FIG. 1 along line A-B of FIG. 3;

FIG. 5 is a top view of a series of the molded sub-floor panels of FIG. 1 connected with nailing strips to form an exemplary sub-floor assembly section according to the  
20 present invention;

FIG. 6 is a cross-sectional view of the sub-floor assembly section along line C-D of FIG. 5;

FIG. 7 is a top view of numerous sub-floor assembly sections of FIG. 5 in an exemplary arrangement for accepting a flooring surface according to the present  
25 invention;

FIG. 8 is a cross-sectional view particularly illustrating the nailing strips along line E-F of FIG. 7;

FIG. 9 is a top view of the arrangement of sub-floor assembly sections of FIG. 7 with a flooring surface attached according to the present invention;

30 FIG. 10 is a cross-sectional view of the flooring assembly of FIG. 9 along line G-H of FIG. 9;

FIG. 11 is cross-sectional view of a further exemplary molded sub-floor panel along line A-B of FIG. 3;

FIG. 12 illustrates top views of further exemplary sub-floor panels having various shapes according to the present invention;

FIG. 13 is a sectional view of a further exemplary flooring system according to the present invention;

5 FIG. 14 is a top view of the exemplary flooring system illustrated in FIG. 13;

FIG. 15 is a sectional view of a still further exemplary flooring system according to the present invention;

FIG. 16 is a top view of the flooring system illustrated in FIG. 15;

10 FIG. 17 is a sectional view of a still further exemplary flooring system according to the present invention;

FIG. 18 is a top view of the flooring system illustrated in FIG. 17;

FIG. 19 is a sectional view illustrating a yet further exemplary arrangement using an additional resilient component according to the present invention;

15 FIG. 20 is a sectional view of a yet further exemplary arrangement using an additional flooring supporting component according to the present invention;

FIG. 21 is a perspective bottom view of a further exemplary molded sub-floor panel section made according to the present invention;

FIG. 22 is a top view of the molded sub-floor panel section illustrated in FIG. 21;

20 FIG. 23 is a top view of a series of the molded sub-floor panels of FIG. 21 arranged to be connected with nailing strips to form an exemplary sub-floor assembly section according to the present invention; and

FIG. 24 is a top view of numerous sub-floor assembly sections of FIG. 23 with nailing strips in an exemplary arrangement for accepting a flooring surface according to the present invention.

## 25 DETAILED DESCRIPTION

Preferred embodiments of the invention will be described in detail with reference to the figures, wherein like reference numerals represent like parts and assemblies throughout the several views.

30 In general, the present invention relates to a sub-floor for placement below an upper flooring surface generally used for athletic activities which together form a sports flooring.

Referring first to FIG. 1, which is a perspective view of a sub-floor panel 30 preferred to be composed of a suitable synthetic material, such as either recycled or new plastics commonly used when manufacturing molded components. While the sub-floor

panel **30** is shown having a preferred octagon shape, it will be appreciated, as evidenced by FIG. 12, that the sub-floor panel can be provided in nearly limitless alternate shapes while remaining within the scope of the invention. The sub-floor panel **30** includes upper surface sections **31** and a center nailer plate **32** disposed intermediate the upper surface sections **31**. Center nailer plates **32** are preferred to be manufactured in a thin dimension of 1/16" to 1/8" thickness and placed at a height below the upper surface sections **31** and at a height above the lower surfaces of the sub-floor panel **30** to thereby form opposed channels into which nailing sections are to be placed. The center nailer plate **32** may also include strategically placed voids **33** to allow for placement of an adhesive to assist in integration of nailing sections which will be described further in detail below.

FIG. 2 shows the underside of a sub-floor panel **30** and illustrates the inclusion of cavities **34** manufactured below the underside of upper surface sections **31**. FIG. 2 also details positioning of the thin center nailer plate **32** in relation to upper surface sections **31** and lower surfaces of the sub-floor panel **30**. While the cavities **34** are shown in a preferred alignment it is to be understood that the cavities **34** can be provided in alternate patterns that are nearly limitless. Cavities **34** allow housing of resilient pads **35** below the underside of the sub-floor panel **30**. Resilient pads **35** are preferably manufactured of rubber, urethane, PVC, neo-prene or other materials that are commonly included in resilient sports floor construction.

FIG. 3 is a top view of a sub-floor panel **30**. In this illustrated example, the dimension of the center nailer plate **32** measures 4" x 15" and the dimension across the sub-floor panel **30** is 15" when following the line as shown from A to B. Angled walls **36** of upper sub-floor sections **31** measure 8" in length and are aligned at 45 degree angles to the elongated edges of the center nailer plate **32**.

FIG. 4 provides a cross-sectional view of a sub-floor panel **30** as shown along a line A-B in FIG. 3. The overall profile height of the sub-floor panel **30** in this illustrated system measures 3/4". A series of cavities **34** are included below upper sub-floor sections **31** on both sides of the center nailer plate **32**. Resilient pads **35** are shown housed in strategic locations in sectional cavities **34**. Resilient pads **35** are provided in a thickness that allows the resilient pads **35** to extend below the bottom surfaces of the sub-floor panel **30** as is illustrated to thereby allow downward deflection of the sub-floor panel **30** when loads are applied on the surface of the flooring system.

FIG. 5 is a top view of a series of sub-floor panels **30** as held in place with an upper nailing strip **37** and lower nailing strip **38** to form a sub-floor section **39**. The

nailing strips **37** & **38** are preferably constructed of plywood or other suitable wood component known to soundly accept anchorage of common mechanical fasteners such as staples or cleats. In this illustrated example, nailing strips **37** & **38** are preferably 96" in length but can be set at any preferred dimension to allow desired spacing between sub-floor panels **30**. Nailing strips **37** & **38** are aligned parallel with the elongated edges of the opposed channels formed by the arrangement of the center nailer plates **32** provided in the sub-floor panels **30**.

Upper nailing strip **37** is preferably dimensioned narrower than lower nailing strip **38**. Lower nailing strip **38** is preferably dimensioned slightly narrower than the width of the center nailer plates **32** and positioned on the underside of the sub-floor panels **30** against the bottom of the nailer plates **32**. Upper nailing strip **37** is positioned on the top side of the sub-floor panels **30** against the top of the nailer plates **32**.

Attachment of upper nailing strip **37** and lower nailing strip **38** thereby sandwiching the nailer plates **32** is most preferably accomplished by means of mechanical fasteners such as suitable staples and adequate adhesive.

The upper nailing strip **37** is shown to extend beyond the edge of the end sub-floor panel **30**. The lower nailing strip **38** is shown to extend beyond the edge of the opposite end panel **30**. In this manner, the upper nailing strip **37** used primarily in connection with one set of sub-floor panels **30** can be attached to the lower nailing strip **38** used in connection with a second, abutting set of sub-floor panels **30**. For example, FIG. 7 is a top view of numerous sub-floor sections **39** and illustrates the ends of upper nailing strips **37** overlapping onto the center of an abutting sub-floor panel **30** whereby attachment of the upper nailing strips **37** to an abutting sub-floor panel **30**, and its lower nailing strip **38**, is preferably accomplished by means of mechanical fasteners such as staples and/or suitable adhesive.

FIG. 6 illustrates a view of the nailing strips along line C-D in FIG. 5 particularly showing the positioning of upper nailing strip **37** and lower nailing strip **38** which, when attached, sandwich center nailer plates **32** of sub-floor panels **30**. Upper nailing strip **37** is preferably manufactured 1" narrower than lower nailing strip **38**. Centering upper nailing strip **37** in relation to the center of lower nailing strip **38** thus forms two shoulders aligning along both elongated edges of nailing strips **37** & **38** as illustrated.

In FIG. 6 the resilient pads **35** are shown as positioned within sub-floor panel cavities **34**. Resilient pads **35** are preferably held in position with pressure by sizing the width of resilient pads **35** slightly greater than the width between side walls of sub-floor

cavities **34**. Resilient pads **35** can also be held into position with other attachment means such as suitable adhesive. As previously noted, the profile height of resilient pads **35** is a dimension selected to extend beyond the underside surfaces of the sub-floor panel **30** and lower nailing strip **38** to allow deflection of resilient pads **35** when loads occur on the  
5 flooring system.

Returning to FIG. 7, adjacent sub-floor section **39** rows are preferably positioned to provide uniform spacing between sub-floor panels **30** and optional anchorage clips **40** may be strategically positioned in designated locations between sub-floor panels **30**. For example, FIG. 8 is an end view of nailing strips **37** & **38** and anchorage clip **40** positioned  
10 in a span between sub-floor panels as shown along line E-F in FIG. 7. Shoulder areas are shown as being formed by the top edges of lower nailing strip **38** owing to the offset side edges of upper nailing strip **37**. The formation of shoulder areas on the upper edges of lower nailing strip **38** allows strategic placement of the anchorage clip **40**. The anchorage clips **40** provide a means by which to integrate the sub-floor system to the supporting  
15 substrate surface, which is most typically concrete. The anchorage clip **40** includes a lower horizontal flange which rests on the substrate and allows penetration of a fastener **41**, which is most commonly a steel drive pin suitable for concrete anchorage. The upper flange of the anchorage clip **40** rests soundly on the surface of the lower nailing strip **38** in a manner that adds stability to the floor system and facilitates solid contact between  
20 resilient pad components and the concrete substrate. The anchorage clip **40** is preferred to be 2" in length and manufactured of steel in an adequate thickness of 16 to 20 gauge. The profile height of the anchorage clip **40** is such that the top flange is positioned to provide slight downward pressure onto the top of the lower nailing strip **38**. The anchorage clip **40** thus allows downward deflection of the flooring system against the  
25 resilient forces of the resilient pad components as surface loads are applied to the flooring while limiting upward movement of the sub-floor assembly.

FIG. 9 is top view of a series of sub-floor panel sections **39** with flooring surface **42** material attached. The most preferred floor surface **42** is tongue and groove wood flooring material commonly used in gymnasium sports flooring applications. Flooring  
30 surface **42** attachment is most preferably accomplished by means of mechanical fasteners such as staples or cleats driven through upper and lower nailer strips **37** & **38**. The flooring surface **42** can also be soundly attached by means of applying suitable adhesive to the surfaces of the upper nailer strip **37**.

FIG. 10 illustrates a sub-floor panel **30** and flooring surface **42** along line G-H in FIG. 9. Flooring surface **42** is shown to rest on the upper surface **31** of the sub-floor panel **30** and upper nailing strip **37**.

FIG. 11 provides a cross-sectional view of a further sub-floor panel **30** underside as shown along a line A-B in FIG. 3. This detail illustrates a manner in which profile ridges **43** are provided to extend downward from the underside of the upper surface section **31**. Multiple profile ridges **43** can be provided as desired in cavities **34**. The dimension in width and length and number of profile ridges is implemented as related to preferred profile and performance of resilient pads **35**. Incorporating profile ridges **43** allows reduced height of resilient pads **35** and also allows adjustment to desired floor system resiliency dependent on contact between the surface of the resilient pads **35** and the bottom edge or edges of profile ridges **43**.

FIG. 12 functions to illustrate various alternative sub-floor panel shapes **x**, **y**, & **z** as well as the various alternative sub-floor panels formed in arrangement with nailing strips **37** & **38** to create sub-floor sections. Alternate shapes such as illustrated in FIG. 12 or other customizing of the preferred octagonal sub-floor panel shape, shown in FIG. 1, are within the scope of the invention.

FIGS. 13 and 14 illustrate another exemplary flooring system in which the sub-floor is formed by combining a synthetic flat plate **44** with upper nailing strips **37** and lower nailing strips **38**. The synthetic flat plate **44** is preferably manufactured through a suitable process such as molding or extrusion as known for fabrication of plastic materials. The underside of the flat plate **44** includes strategically placed resilient pads **35** manufactured from material as previously described with respect to FIG. 2. In this further exemplary system, upper nailing strip **37** and lower nailing strip **38** are most commonly attached by means of mechanical fasteners passing through both nailing strips **37** & **38** as held in position against the top and bottom of the flat plate **44** respectively. The use of adhesive between the flat plate **44** and nailers **37** & **38** is also a suitable means to provide attachment. The flat plate **44** may also include legs **45** protruding from the underside of the plate **44** to form cavities **34** for preferred positioning of resilient pads **35**.

Surface voids **46** between edges of upper nailers **37** can include placement of filler material **47** to support the flooring surface **42**. Filler material **47** is most preferably flexible material such as low density blanket foam.

In this further exemplary flooring system, it is to be understood that there need not be an established limit to the width or length of the flat plate **44**, which can be provided in

a dimension suitable to incorporate only one upper and one lower nailer **37 & 38** or in a width that allows the attachment of multiple upper and lower nailer **37 & 38** combinations as shown. Nevertheless, a preferred dimension of the flat plate **44** is 48" in width and 96" in length when incorporating multiple nailers **37 & 38**. A thickness of the flat plate **44** is preferably 1/8" but can be provided in any thickness determined as a dimension most suitable for desired support and flexibility related to activities on the floor. The flooring surface **42** is most typically attached to nailing strips **37 & 38** by means of mechanical fasteners such as staples or cleats. As seen in FIG. 14, the upper nailing strips **37** preferably have one end which extends (e.g., 6") beyond the end of the synthetic flat plate **44** with the opposite end resting (e.g., 6") short of the end edge of the synthetic flat plate **44**. The offset alignment allows overlapping of end joints of upper nailing strips **37** onto synthetic flat plates **44**, and nailing strips **38**. The distance by which the ends extend can be adjusted as desired for preferred integration.

It is also to be appreciated that, while the flat plate **44** is preferably manufactured as a solid panel, the flat plate **44** can be manufactured with ridges or interior air chambers and remain within the intended scope of the invention.

When the dimension of the flat plate **44** is established as being 48" in width by 96" in length the flat plate **44** may have attached thereto, for example, four upper and four lower sleeper strips **37 & 38**. In such a case, the preferred dimension of the sleeper strips **37 & 38** is 3" in width and 96" in length spaced 12" on center opposite to the direction of the finished floor surface **42**. As noted above, sizing of the flat plate **44** is practically unlimited and can be adjusted to narrow widths to incorporate, for example, only a single upper and lower nailing strip **37 & 38** and, as such, there is no set limit to the number of nailing strip rows **37 & 38** that need be attached to each flat plate **44**. Rather, the number of nailing strip rows **37 & 38** as well as width dimension and spacing of nailing strips **37 & 38** is most typically dependent on desired support of the flooring surface **42**. In FIG. 14, a preferred arrangement of multiple flat plates **44** is shown wherein the multiple flat plates **44** are placed into a formation by offsetting end joints in alternate rows to create a staggered brick pattern.

FIGS. 15 and 16 illustrate a further exemplary flooring system in which the sub-floor is formed by combining a channeled or slotted plate **48** and nailing strips **49**. The slotted plate **48** is preferably manufactured through a process in which plastics are commonly fabricated by suitable means such as molding or extrusion to produce a panel including channels or depressed slots **50**. The depressed slots **50** are arranged to typically

align parallel to the long dimension of the slotted plate 48. Within such a system the underside of the slotted plate 48 would again include strategically placed resilient pads 35 manufactured from material as previously described with respect to FIG. 2. In this regard, the slotted plate 48 may include legs 45 protruding from the underside of the slotted plate 48 to form cavities 34 for preferred positioning of resilient pads 35 or added support for the surface of the slotted plate 48. Furthermore, within such a system the nailing strips 49 are preferably attached by means of mechanical fasteners passing through from the underside of the slotted plate 48. The use of adhesive between the slotted plate 48 and nailing strips 49 is also a suitable means to provide attachment. Nailing strips 49 are preferably dimensioned in a thickness to allow a generally flush alignment between the surface of the nailing strips 49 and adjacent surface of the slotted plate 48 to allow even support of the underside of the finished flooring surface 42. The flooring surface 42 is typically attached to nailing strips 49 by means of mechanical fasteners such as staples or cleats.

As before, with respect to this illustrated flooring system example, there need not be an established limit to the width or length of the slotted plate 48, which can be provided in a dimension suitable to incorporate only one nailer strip 49 or in a width that allows the attachment of multiple nailer strips 49 such as shown in FIG. 15. In this illustrated example, a dimension of the slotted plate 48 is 48" in width and 96" in length with the depressed slots 50 measuring approximately 1" deep and 3" in width. Nail strips 49 could then be 3" in width, 96" in length, and 1" thick, manufactured of plywood or suitable dimensioned lumber. Again, the nailing strips 49 would preferably have an end extending (e.g., 6") beyond the end of the slotted plates 48 with the opposite end resting (e.g., 6") short of the end edge of the slotted plate 48 with the offset alignment allowing for overlapping of extending end joints of nailing strips 49 onto slotted plates 48, which are preferably fastened together with adhesive or suitable mechanical fasteners such as common staples. As with all illustrated and described embodiments, the depth and width dimensions, in this case of depressed slots 50 and related nailer strips 49, can be adjusted as desired for suitable performance. As illustrated in FIG. 16, slotted plates 48 may again be arranged by offsetting end joints in alternate rows to create a staggered brick pattern.

Turning now to FIGS. 17 and 18 there is illustrated a further exemplary flooring system in which the sub-floor is formed by combining support panels 51 and suspended nailer strips 52. Support panels 51 are preferably manufactured through a process in

which plastics are commonly fabricated by suitable means such as molding or extrusion. Support panels **51** most desirably include cavities **34** formed as described in detail with respect to FIG. 2, but can also be provided as a flat plate profile. The underside of support panels **51** are shown as including strategically placed resilient pads **35** manufactured from material as previously described with respect to FIG. 2. In this further illustrated example, suspended nailing strips **52** include a form of resiliency such as foam blocks **53** or other suitable resilient pads as previously described. The upper surface of support panels **51** and suspended nailing strips **52** are arranged in a flush manner to allow even support against the underside of the finished floor surface **42**.

As shown in FIG. 18 the synthetic support panels **51** would be preferably arranged in a parallel manner along side edges of suspended nailer strips **52**. In the example illustrated, the support panels **51** would measure 9" in width and 18" in length, but are not limited to this size but rather to any suitable dimension that provides desired support and practical manufacturing. The suspended nailer strips **52** in the example illustrated measure 3" in width and 96" in length and can be sized in any suitable dimension that provides an adequate surface for attachment of the finished flooring surface **42**. With this illustrated arrangement, the support panels **51** are preferably spaced between abutting end joints by 1/4" but can be spaced at other suitable dimensions according to desired support and resiliency. Support panels **51** may also include some form to interlock or overlap end joints.

In FIG. 19 there is illustrated an alternate manner to introduce resiliency into the flooring system. To this end, a cushion blanket **55** may be placed below sub-floor panels **30** and lower nailer strips **38** to provide a manner of resiliency to the floor system. A cushion blanket **55** most commonly consists of material such as open cell flexible foam, or other such products that provide desired resilience and support.

In FIG. 20 there is illustrated an alternate manner to introduce a sub base **56** on top of sub-floor panels **30** and nailer strips **37**. The inclusion of a sub base **56** may be preferred for added support or allowance of floor surface materials such as rubber sheet goods or poured urethanes **57** which require continuous monolithic surfaces below.

In FIGS. 21-24 a further embodiment of a sub-floor panel **30** is illustrated. In this embodiment, the center nailer plate **32** disposed intermediate the upper surface sections **31** is formed to extended beyond the edges of the sub-floor panel **30** main body so as to provide a continuous fill between plywood layers at the panel end joints when the sub-floor panels **30** are arranged to receive the plywood nailers as particularly illustrated in

FIG. 23. In addition, barbs **60** are provided in appropriate ones of the cavities **34** to allow for the attachment of resilient pads **35** without the need for adhesives. Ribs **62** provided to the top surface **31** of the sub-floor panel **30** not only provide structural rigidity to the structure, as do the ribs provided to the back side of the top surface **31**, but also function to form channels in which resilient pads can be placed when the sub-floor panels **30** are stacked for shipping. Finally, flanges **66** are provided at the sides of the center nailer plate **32** to assist in the proper alignment of the upper plywood nailers **37** during construction of the sub-floor assembly.

While specific embodiments of the invention have been described in detail, it will be appreciated by those skilled in the art that various modifications and alternatives to those details could be developed in light of the overall teachings of the disclosure. Accordingly, the particular arrangements disclosed are meant to be illustrative only and not limiting as to the scope of the invention which is to be given the full breadth of the appended claims and any equivalents thereof.

15

## CLAIMS

What is claimed is:

1. A sub-floor assembly for supporting a sports flooring, comprising:
  - a sub-floor panel component formed of a plastic material having an upwardly facing channel and an opposed downwardly facing channel having a surface intermediate to the upwardly facing channel and the downwardly facing channel that laterally extends on opposite sides beyond a main body of the sub-floor panel component;
  - a first strip of anchoring material disposed within the upwardly facing channel;
  - and
  - 10 a second strip of anchoring material disposed within the downwardly facing channel;
  - wherein the first strip of anchoring material and the second strip of anchoring material are configured to sandwich the surface between the first strip of anchoring material and the second strip of anchoring material providing a means by which the sports
  - 15 flooring is attachable to the sub-floor panel component,
  - wherein the sub-floor assembly comprises a resilient material on which is carried the sub-floor panel component.
2. The sub-floor assembly as recited in claim 1, wherein the first strip of anchoring
- 20 material and the second strip of anchoring material each comprise a wood product.
3. The sub-floor assembly as recited in claim 1, comprising a mechanical fastener used to attach the first strip of anchoring material to the second strip of anchoring material.
- 25 4. The sub-floor assembly as recited in claim 1, wherein the surface has at least one opening and an adhesive is used to attach the first strip of anchoring material to the second strip of anchoring material via the opening.
- 30 5. The sub-floor assembly as recited in claim 1, wherein the resilient material is attached to an underside of the sub-floor panel component.
6. The sub-floor assembly as recited in claim 1, wherein the resilient material is disposed in a channel formed in an underside of the sub-floor panel component.

7. The sub-floor assembly as recited in claim 6, wherein the channel formed in the underside of the sub-floor panel component in which the resilient material is disposed has one or more barbs for engaging the resilient material.

5 8. The sub-floor assembly as recited in claim 1, wherein the sub-floor panel component has an octagon shape.

9. The sub-floor assembly as recited in claim 1, wherein a top surface of the sub-floor component has ribs and channels formed in between the ribs.

10

10. A sub-floor assembly for supporting a sports flooring, comprising:

a sub-floor panel component formed of a plastic material having an upwardly facing channel and an opposed downwardly facing channel with a surface intermediate to the upwardly facing channel and the downwardly facing channel wherein the first

15 upwardly facing channel has inwardly extending flanges on opposed sides thereof;

a first strip of anchoring material disposed within the upwardly facing channel;

and

a second strip of anchoring material disposed within the downwardly facing channel;

20

wherein the first strip of anchoring material is centered in the upwardly facing channel by the flanges and is attached to the second strip of anchoring material thereby sandwiching the surface between the first strip of anchoring material and the second strip of anchoring material with the attached anchoring materials providing a means by which the sports flooring is attachable to the sub-floor panel component,

25

wherein the sub-floor assembly comprises a resilient material on which is carried the sub-floor panel component.

11. The sub-floor assembly as recited in claim 10, wherein the first strip of anchoring material and the second strip of anchoring material each comprise a wood product.

30

12. The sub-floor assembly as recited in claim 10, comprising a mechanical fastener used to attach the first strip of anchoring material to the second strip of anchoring material.

13. The sub-floor assembly as recited in claim 10, wherein the surface has at least one opening and an adhesive is used to attach the first strip of anchoring material to the second strip of anchoring material via the opening.

5 14. The sub-floor assembly as recited in claim 10, wherein the resilient material is attached to an underside of the sub-floor panel component.

15. The sub-floor assembly as recited in claim 10, wherein the resilient material is disposed in a channel formed in an underside of the sub-floor panel component.

10

16. The sub-floor assembly as recited in claim 15, wherein the channel formed in the underside of the sub-floor panel component in which the resilient material is disposed has one or more barbs for engaging the resilient material.

15 17. The sub-floor assembly as recited in claim 10, wherein the sub-floor panel component has an octagon shape.

18. The sub-floor assembly as recited in claim 10, wherein a top surface of the sub-floor component has ribs and channels formed in between the ribs.

20

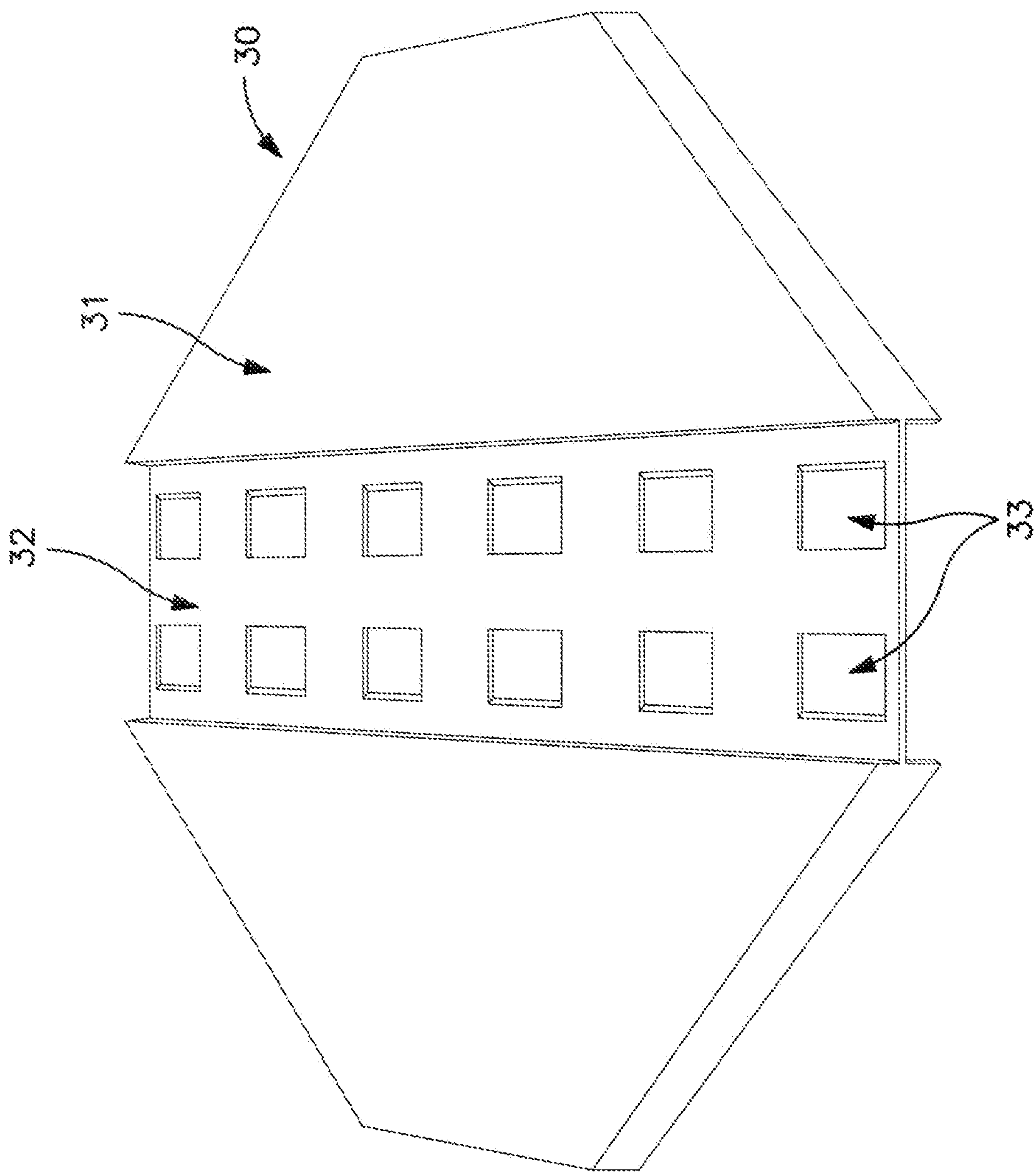

FIG. 1

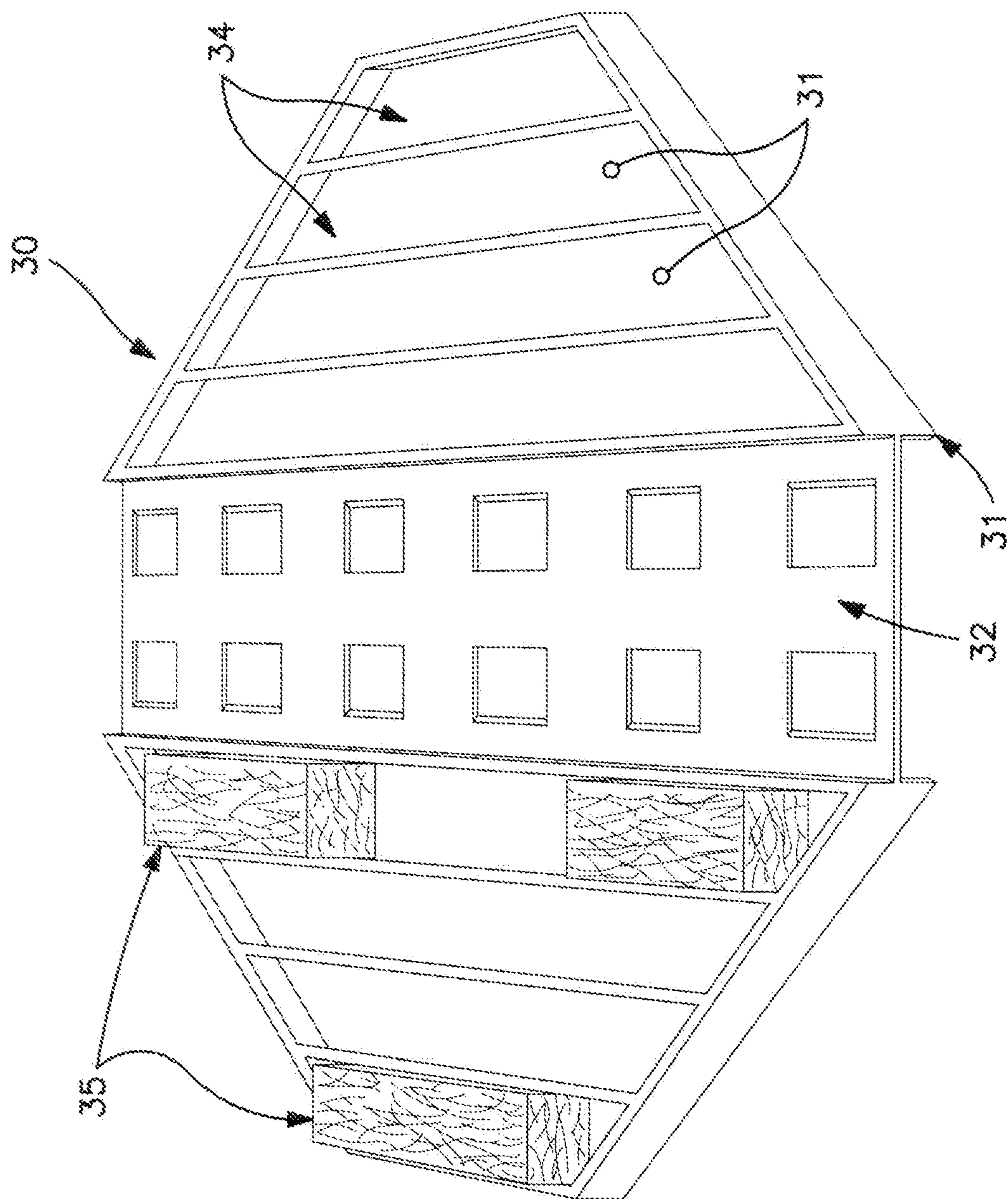

FIG. 2

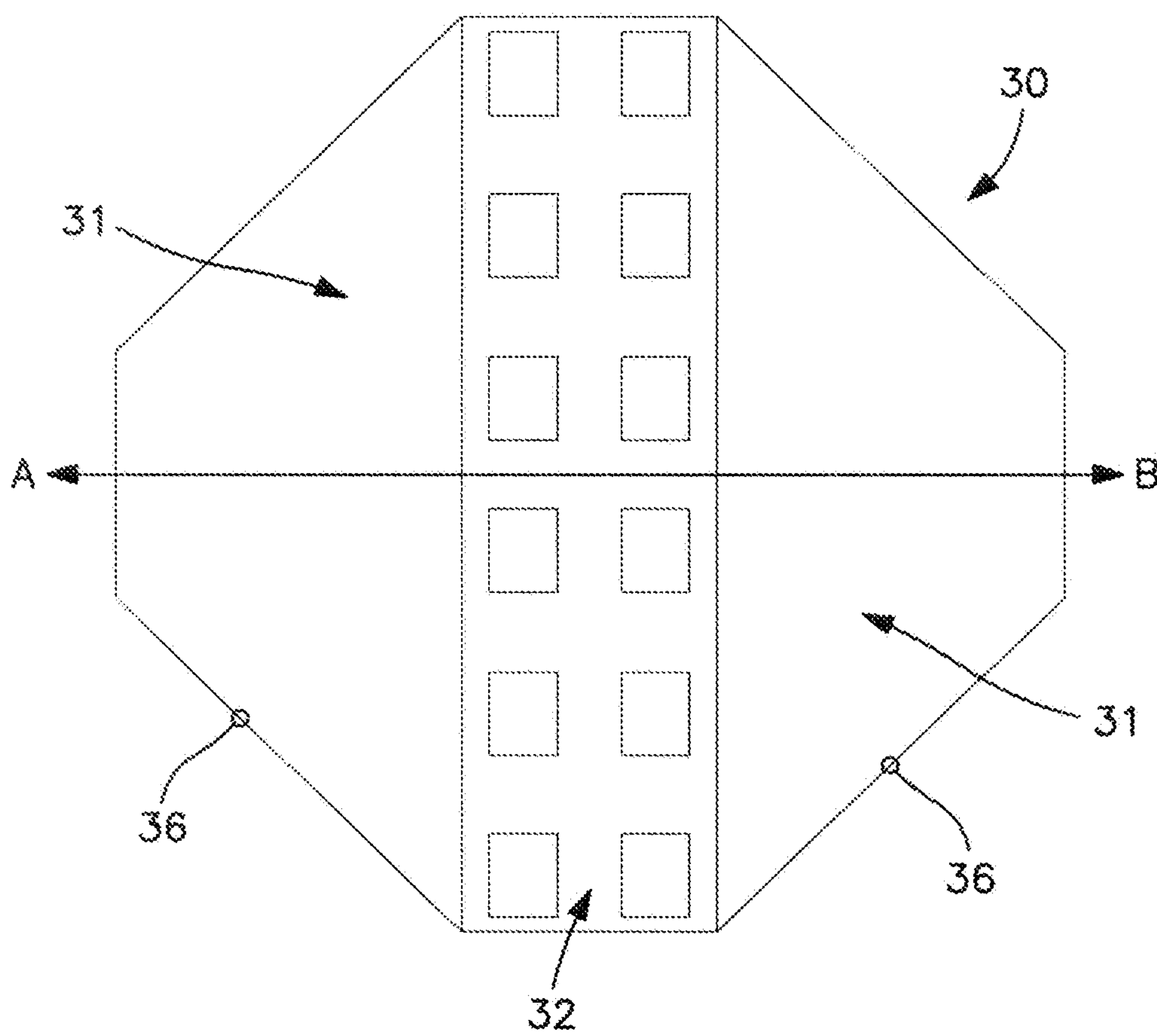

FIG. 3

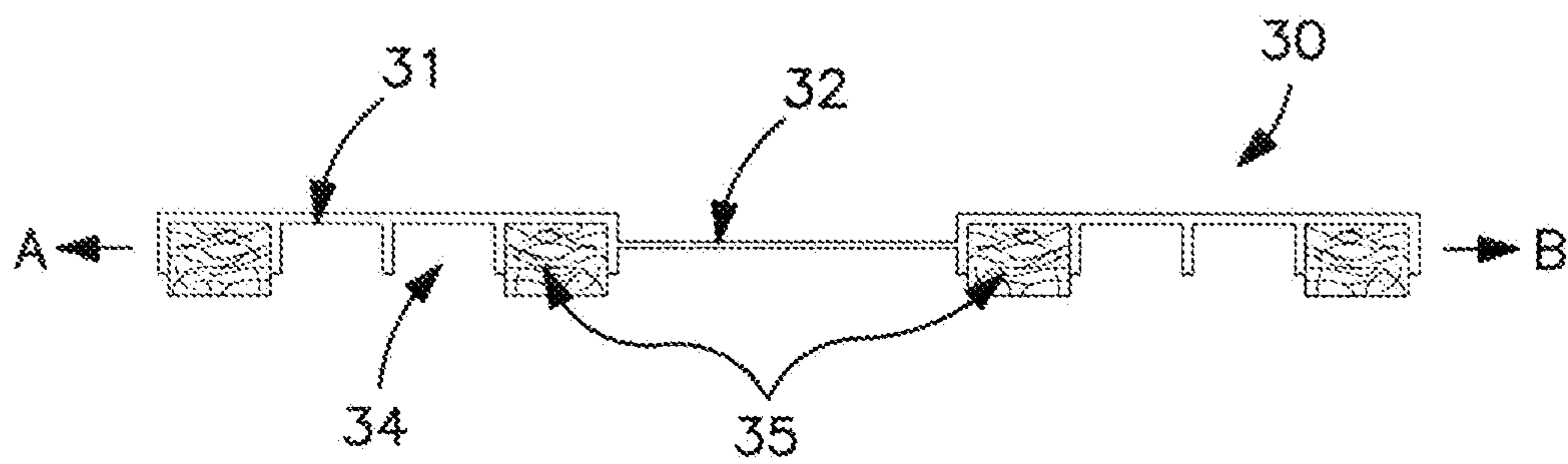

FIG. 4

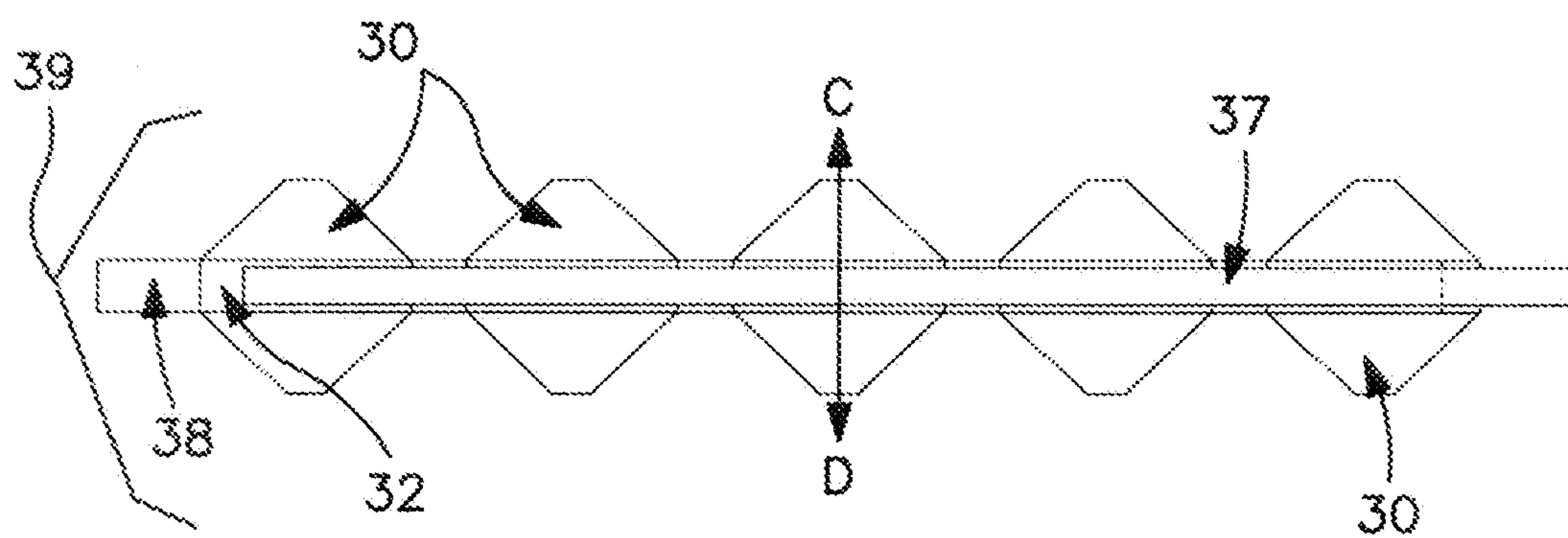

FIG. 5

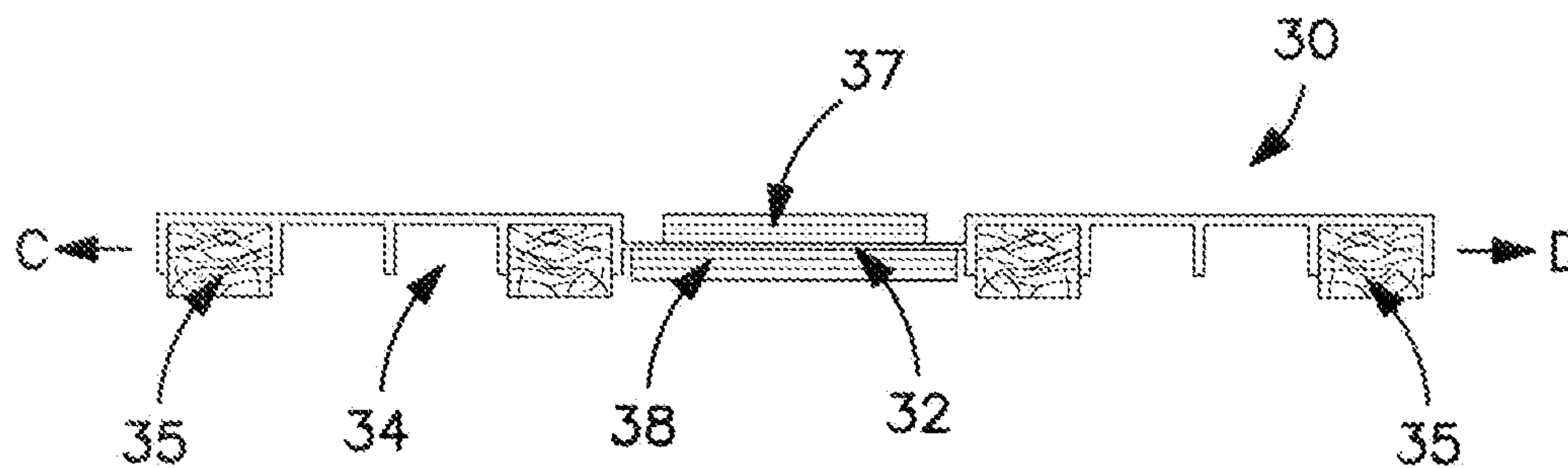

FIG. 6

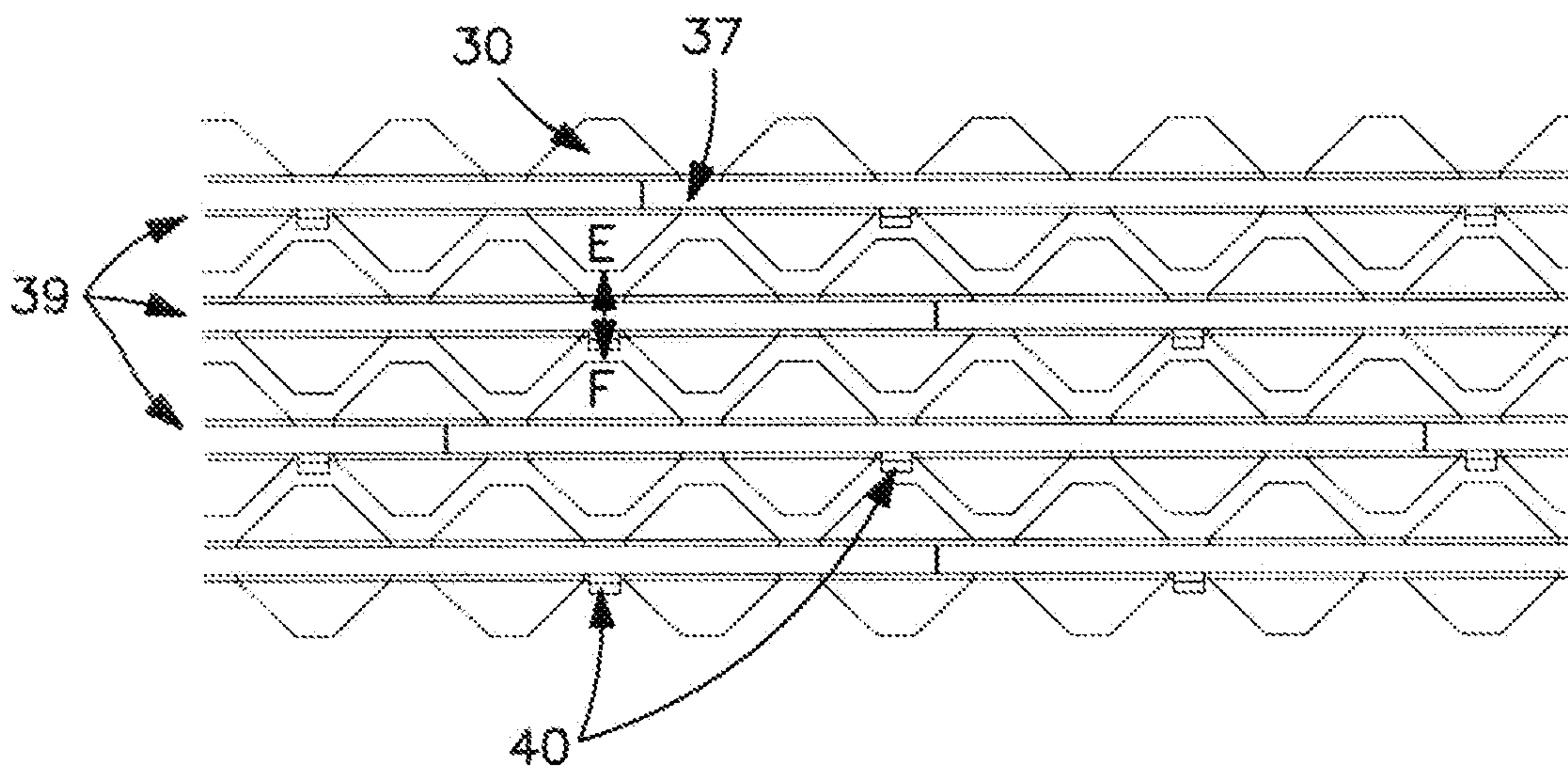

FIG. 7

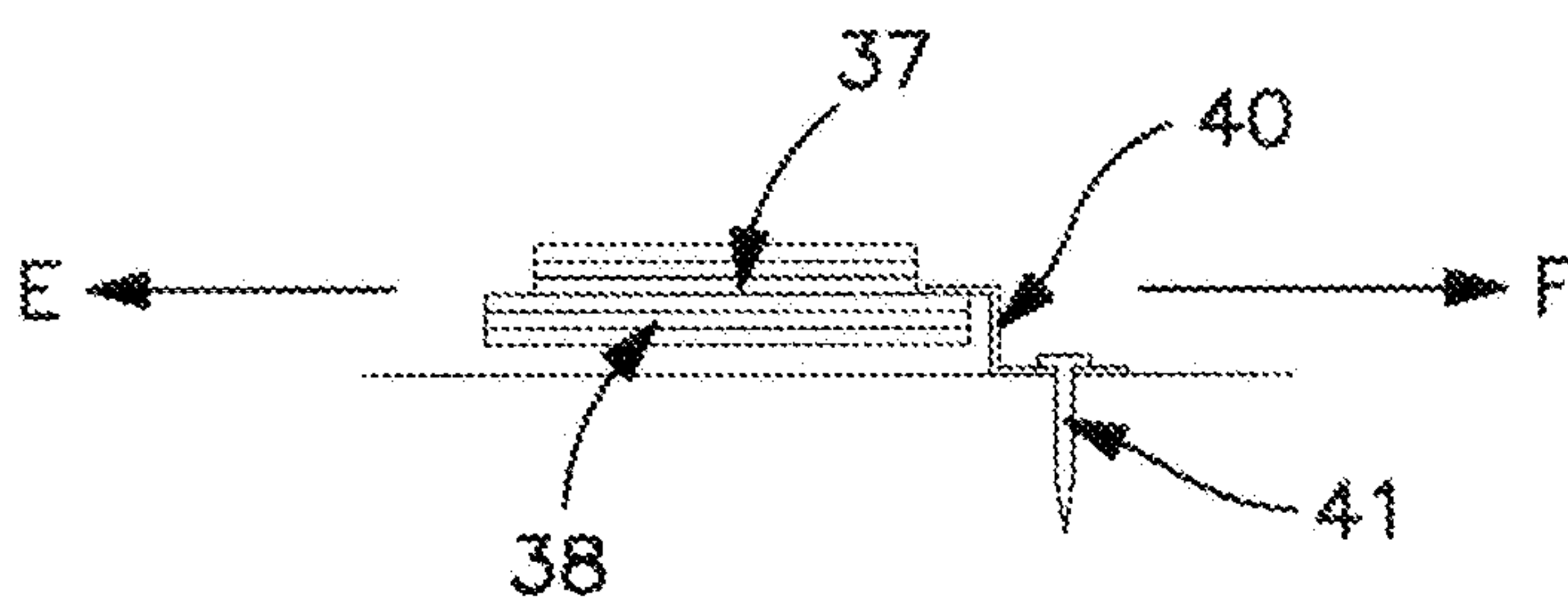

FIG. 8

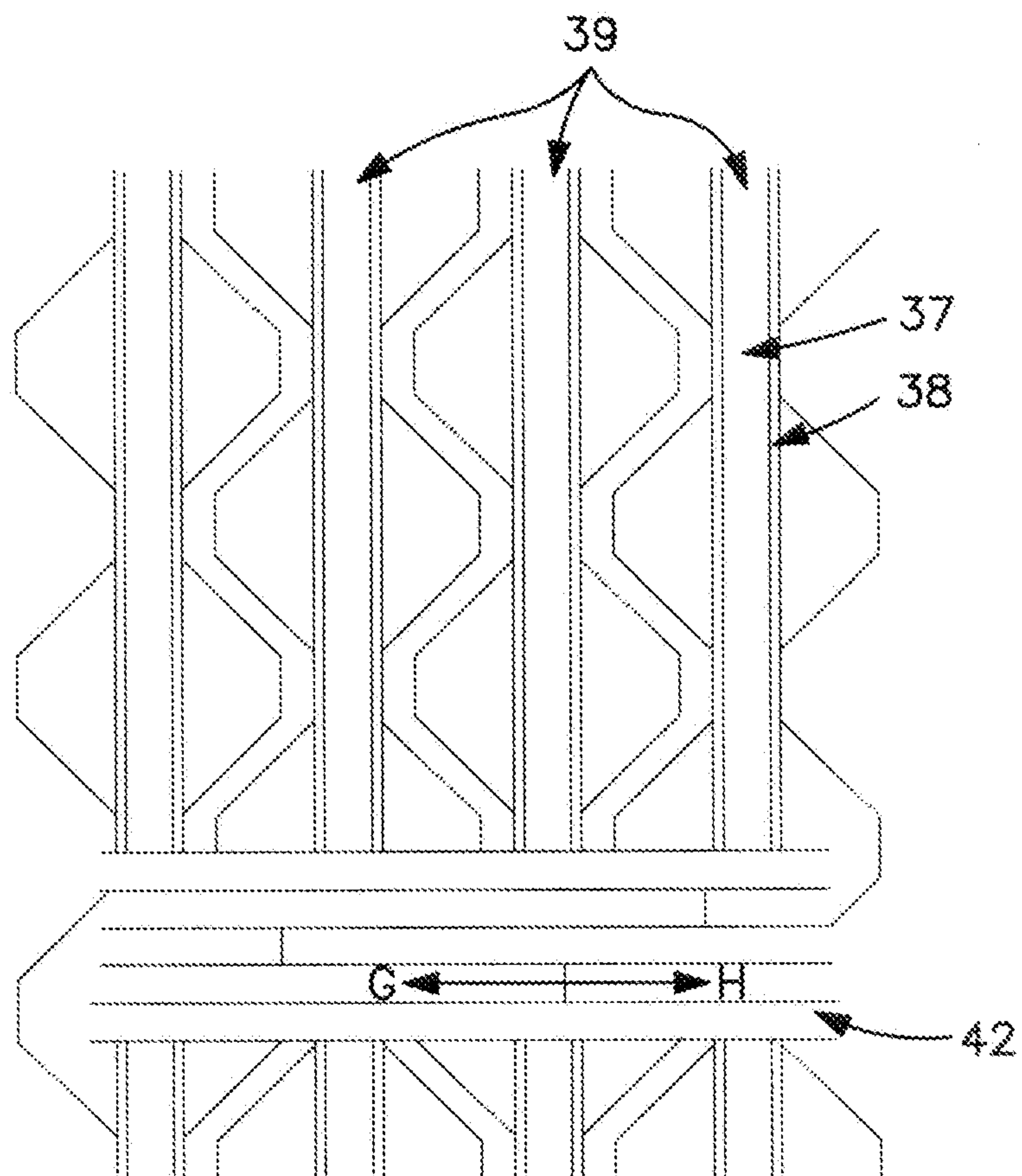

FIG. 9

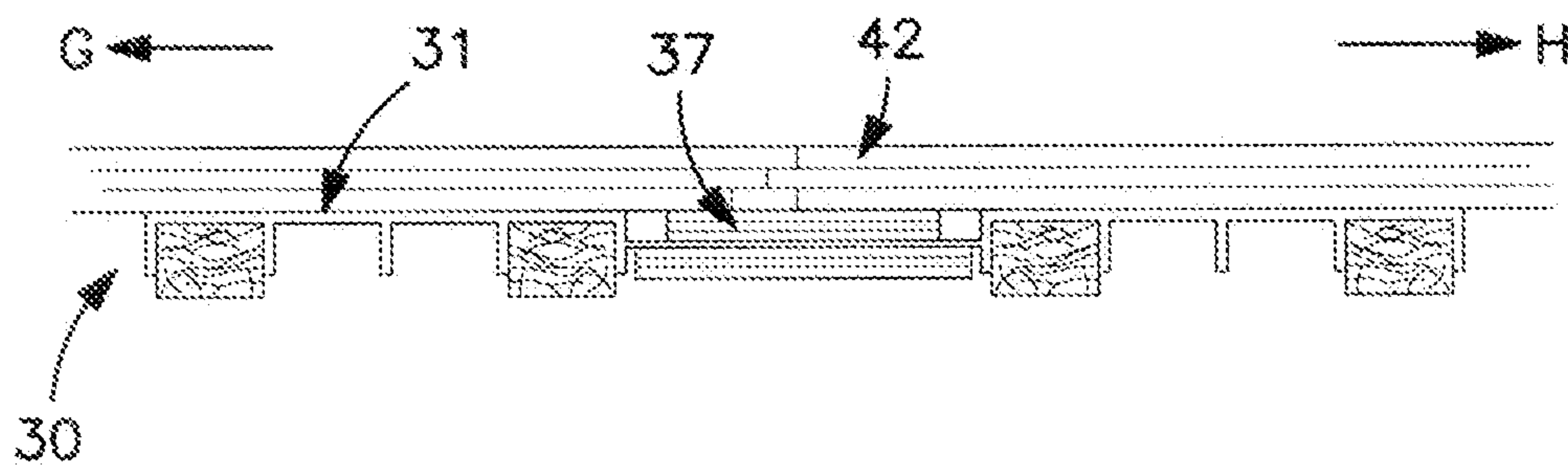
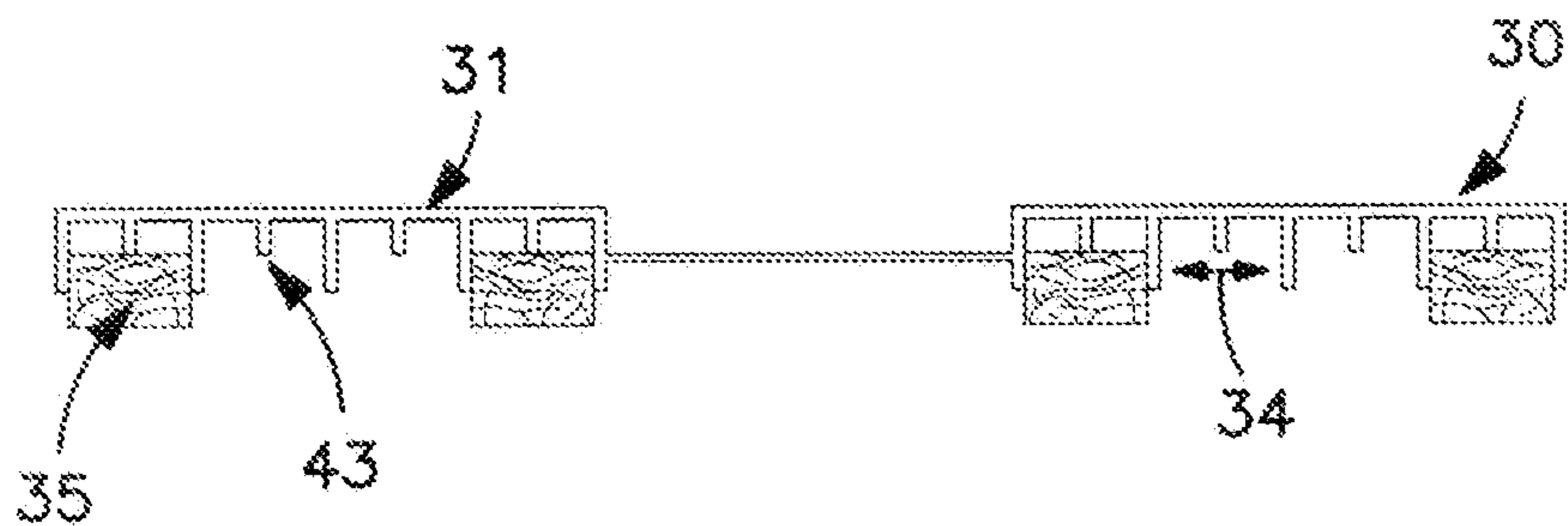
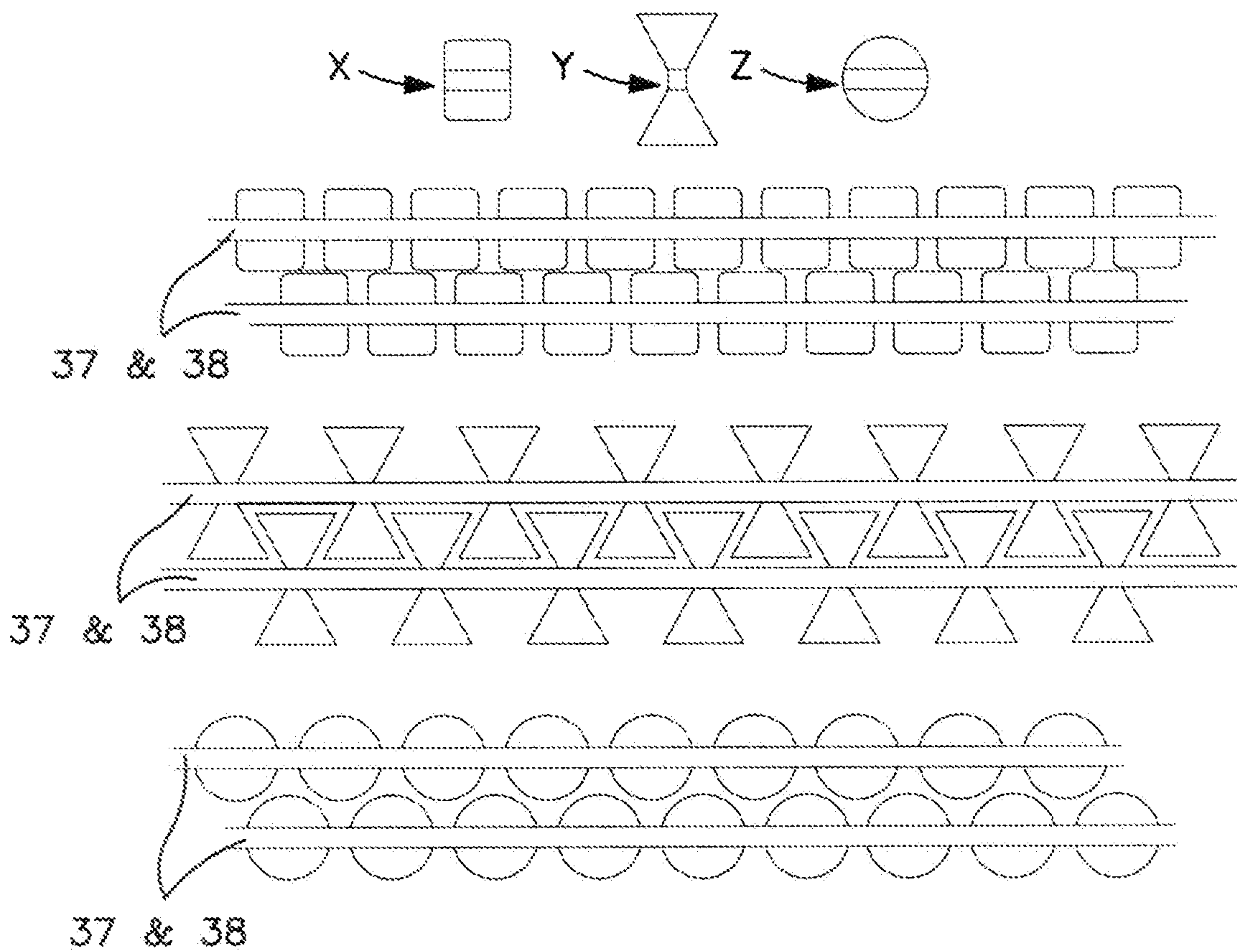

FIG. 10



**FIG. 11**



**FIG. 12**

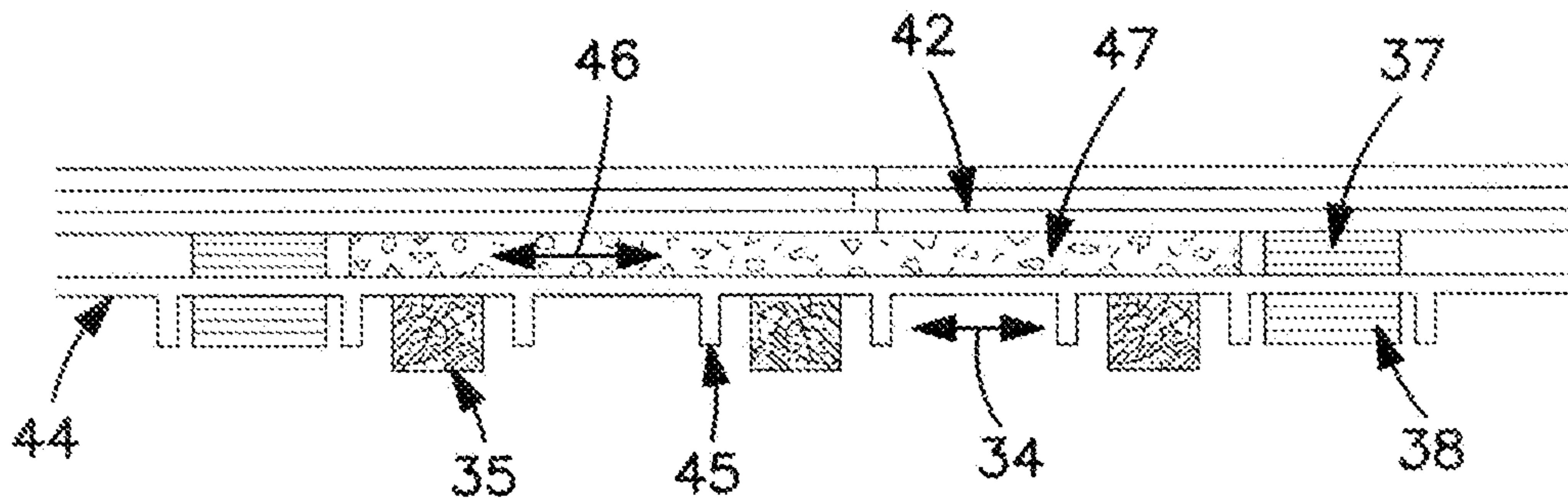

FIG. 13

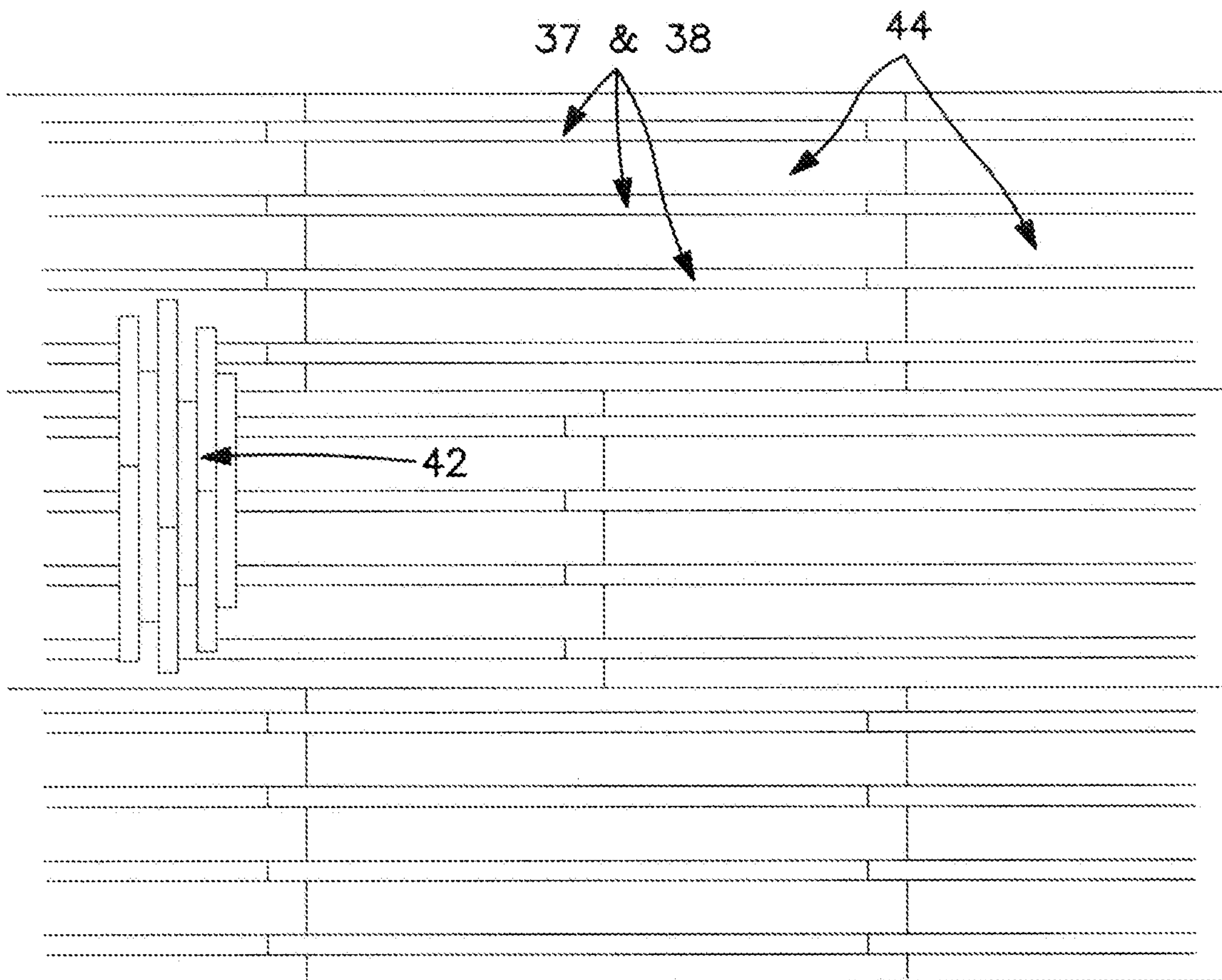
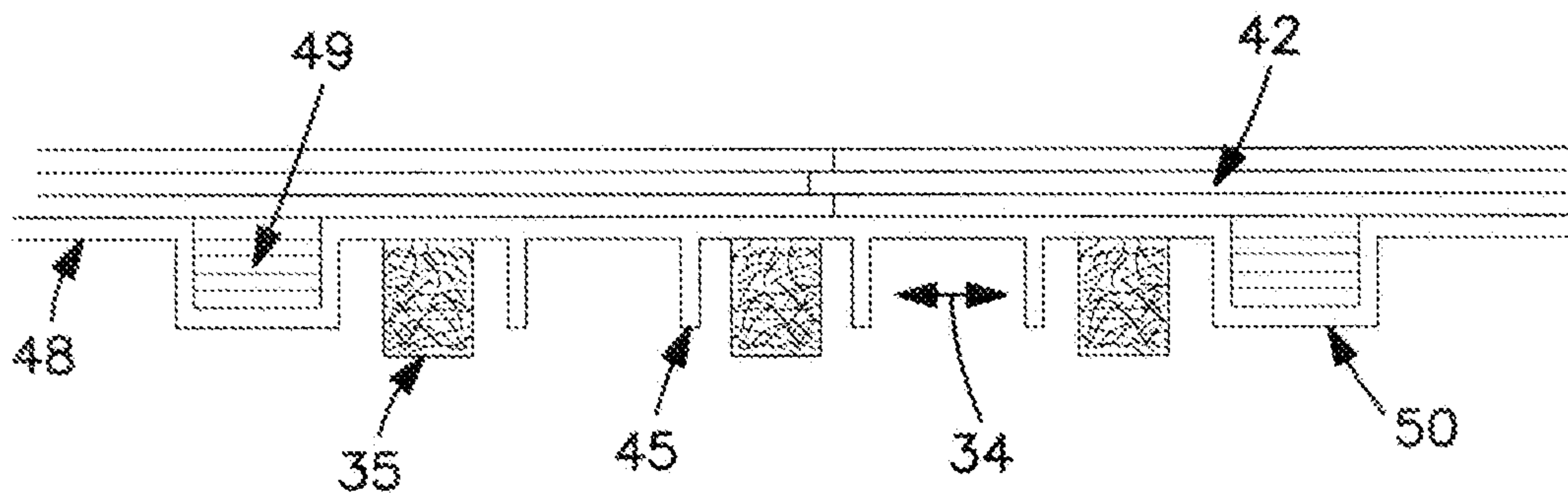
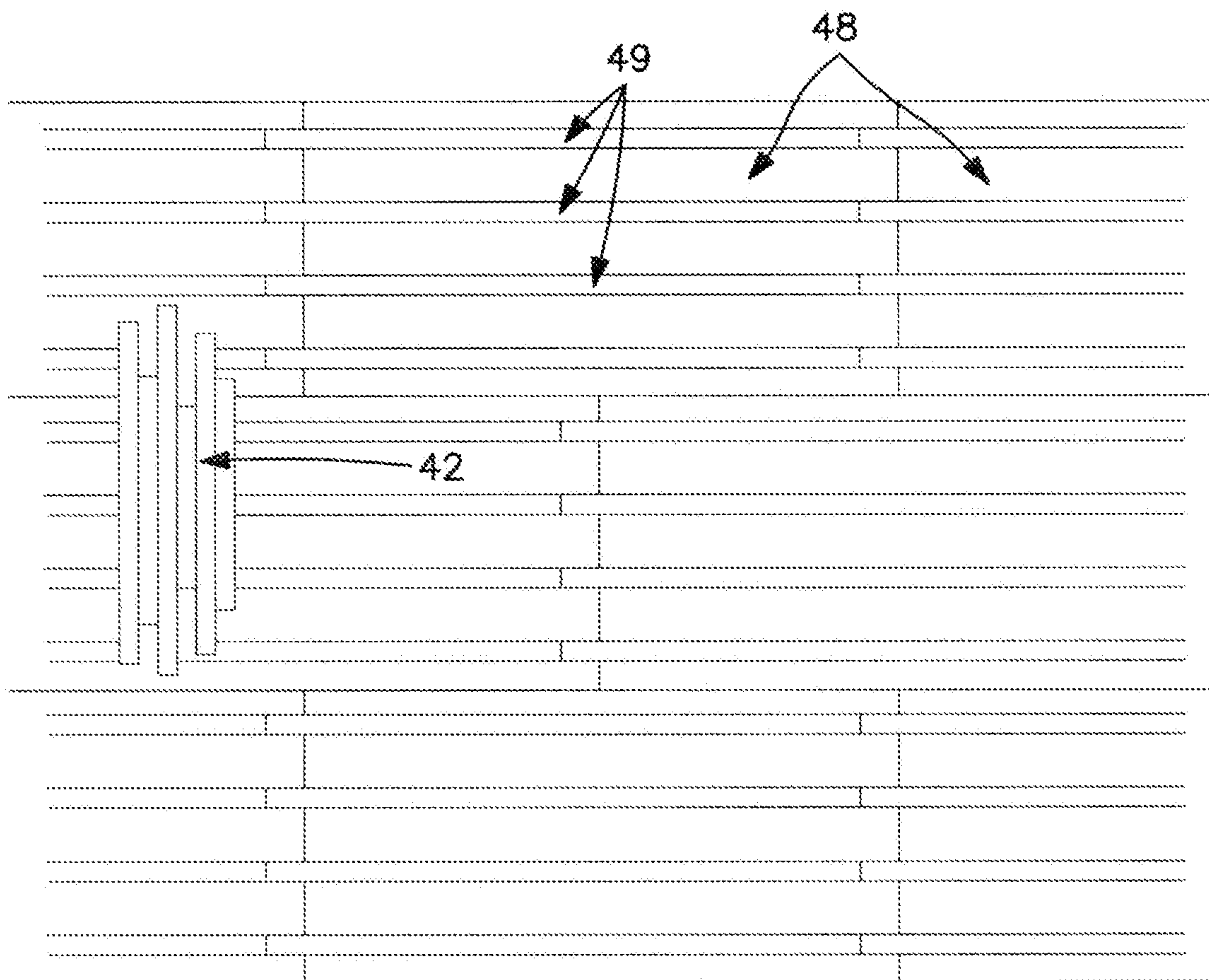

FIG. 14



**FIG. 15**



**FIG. 16**

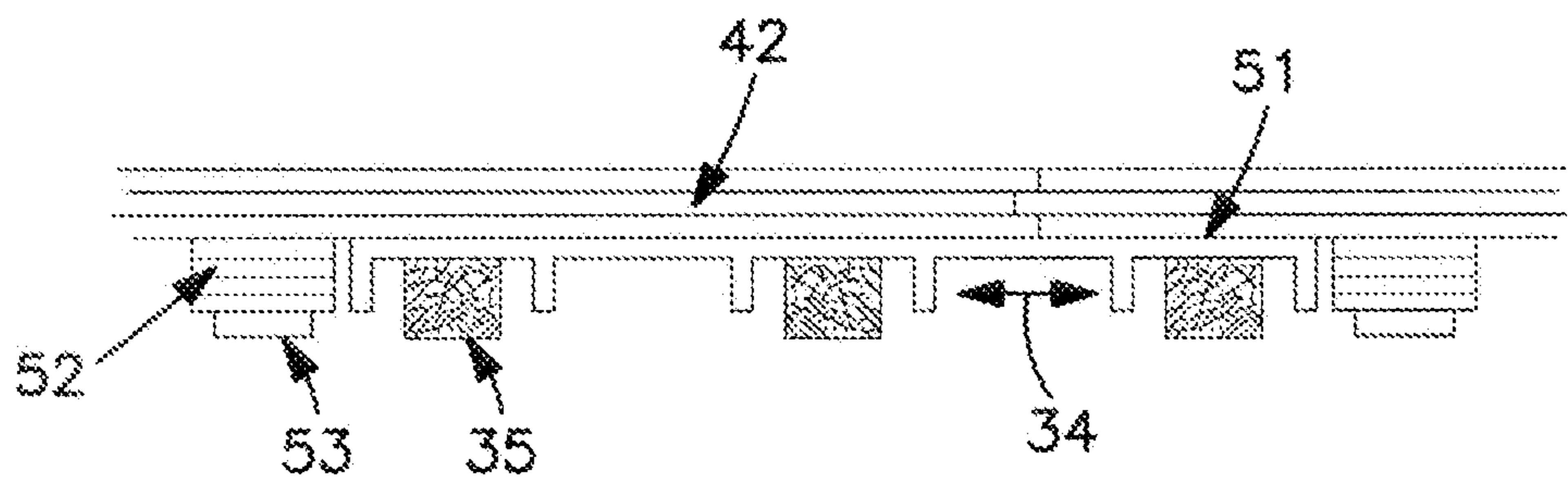

**FIG. 17**

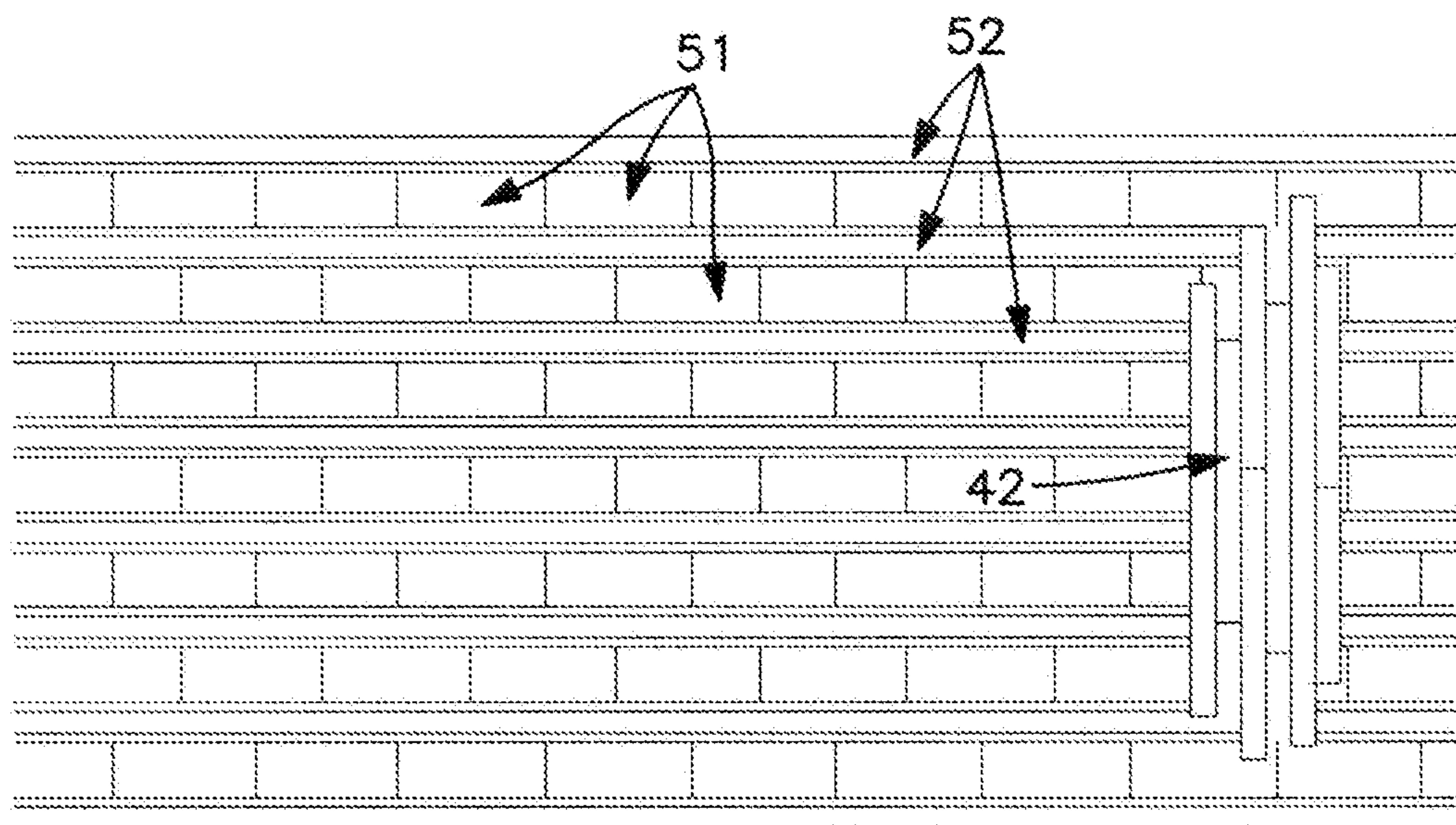

**FIG. 18**

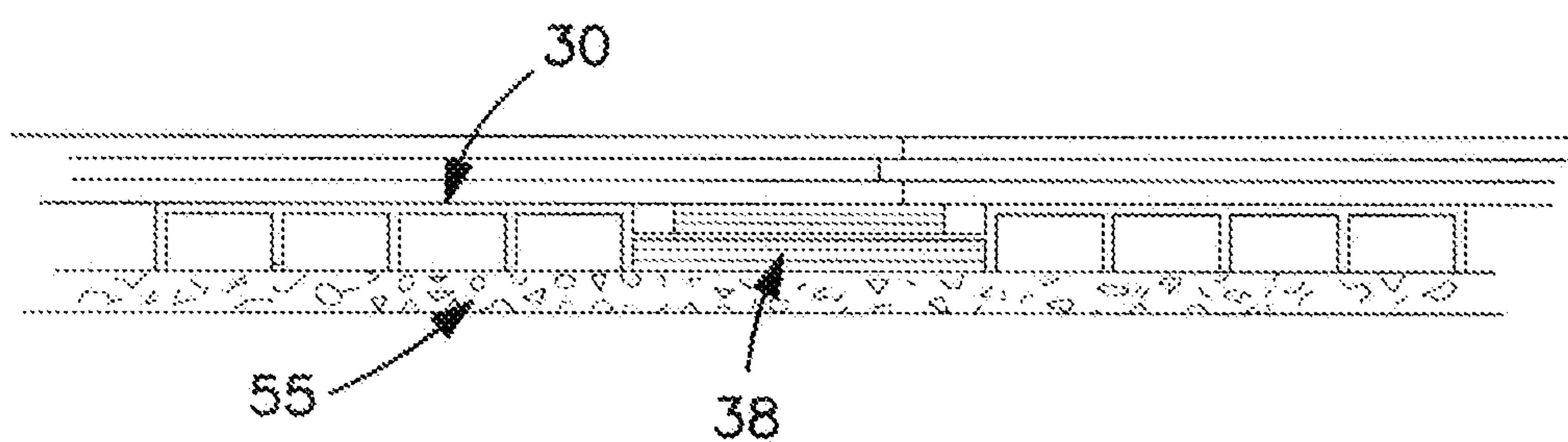

**FIG. 19**

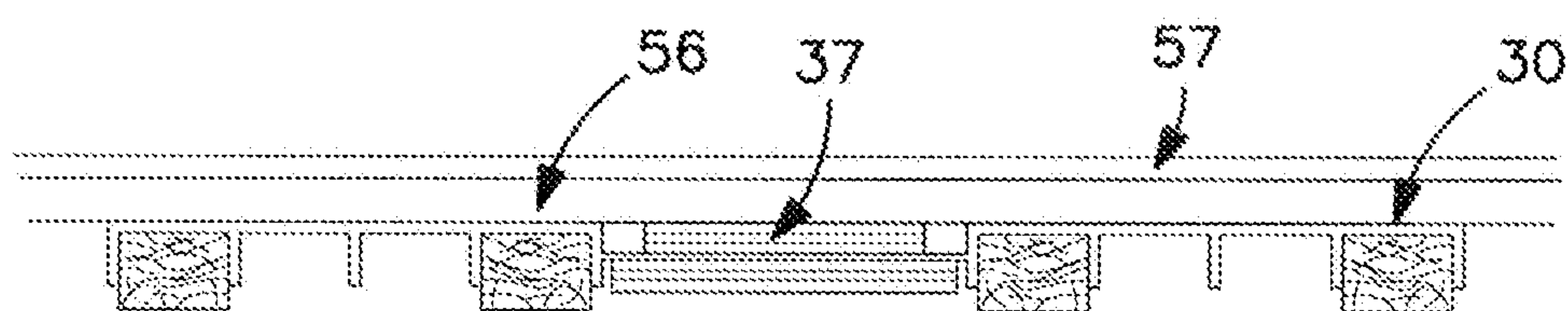

**FIG. 20**

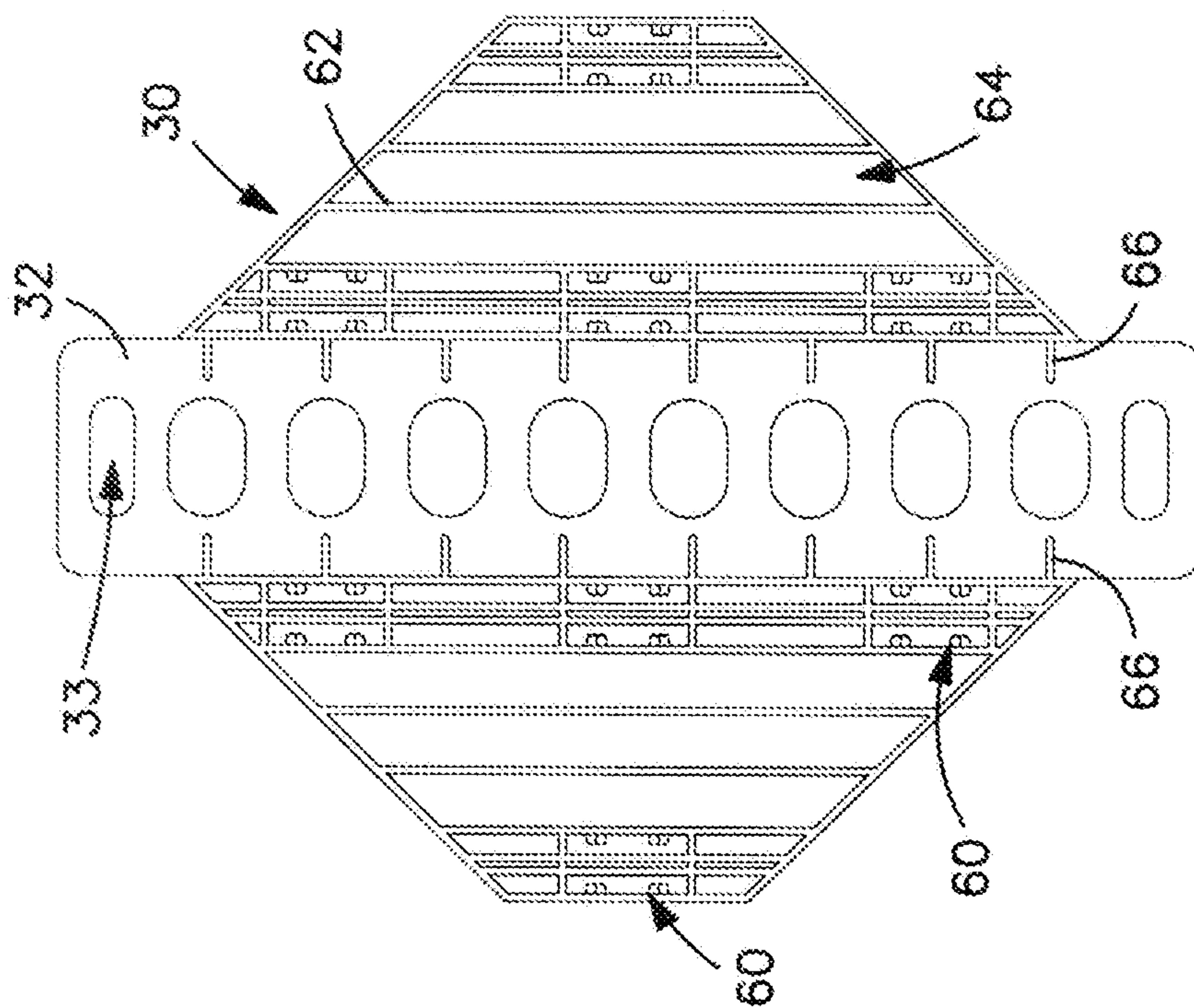

FIG. 22

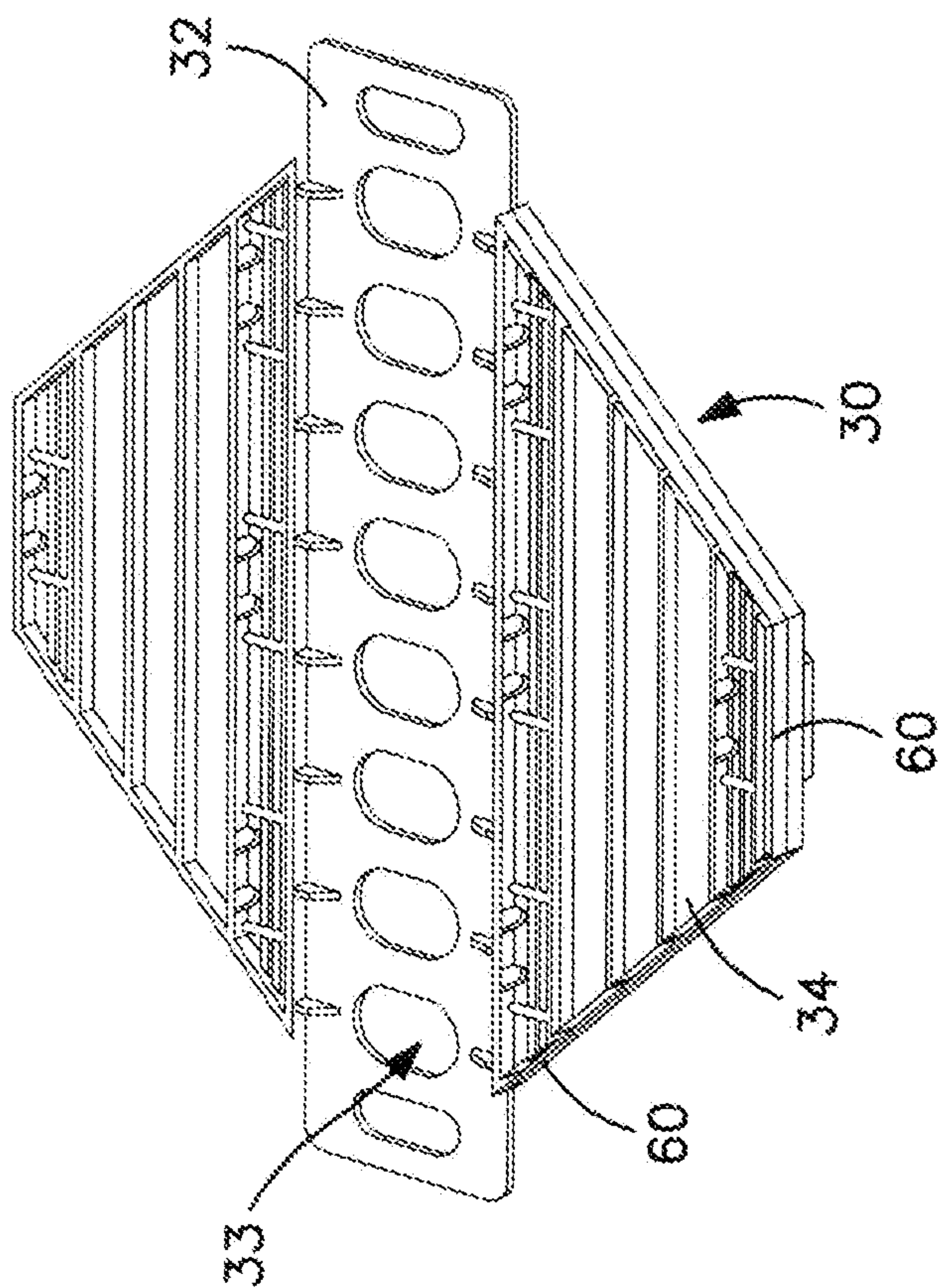

FIG. 21

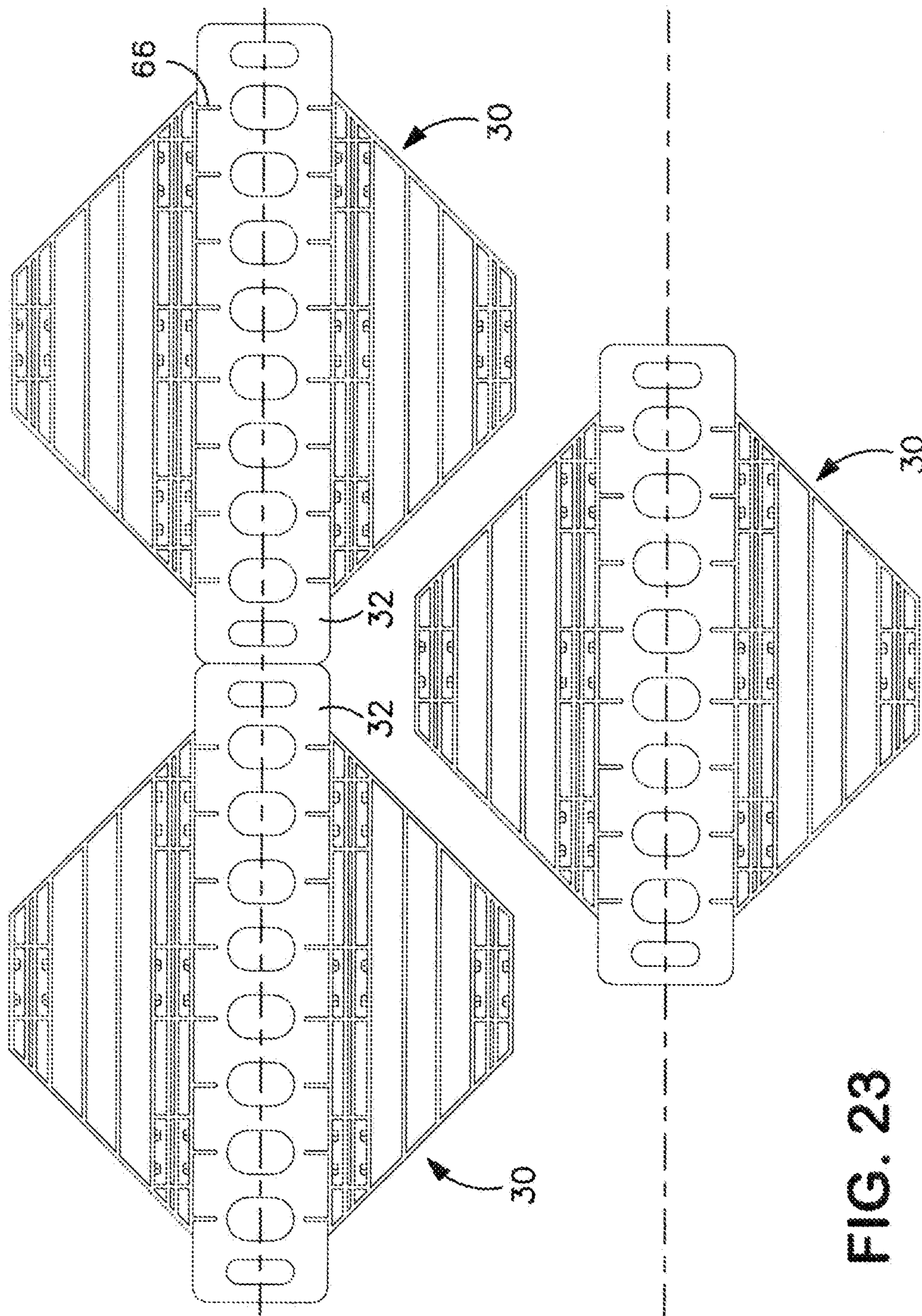

FIG. 23

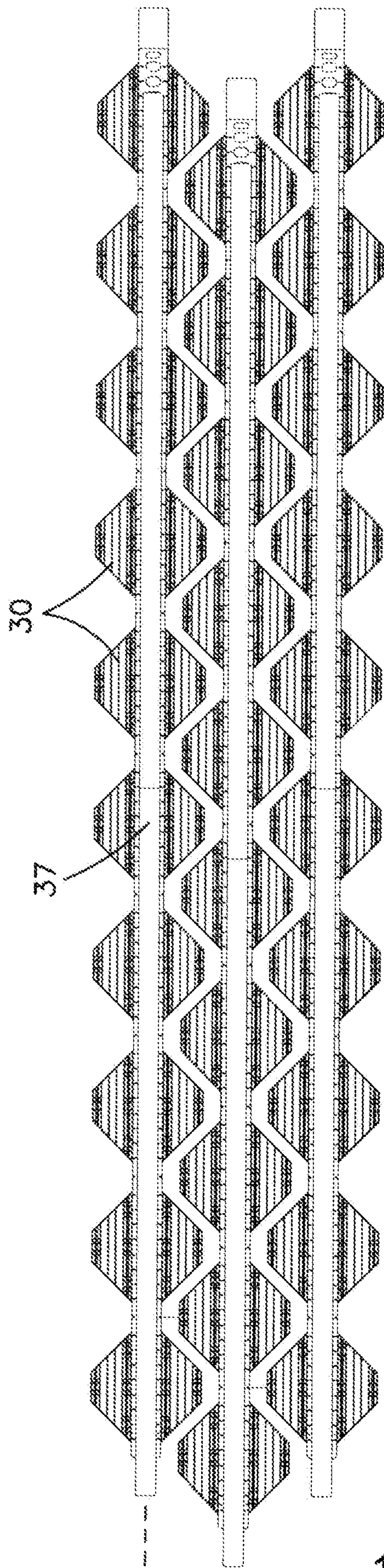

FIG. 24

