

[54] **PROCESS AND APPARATUS FOR PROVIDING STEEL INGOT**

[72] Inventors: **Manfred Wahlster**, Bochum-Stiepel; **Alok Choudhury**, Hattingen, both of Germany

[73] Assignee: **Rhein Stahl Huttenwerke A.G.**, Essen, Germany

[22] Filed: **Nov. 17, 1969**

[21] Appl. No.: **877,371**

[30] **Foreign Application Priority Data**

Nov. 22, 1968 Germany.....P 18 10 371.4

[52] U.S. Cl.....**164/52, 164/252**

[51] Int. Cl.....**B22d 27/02**

[58] Field of Search.....**164/52, 252**

[56] **References Cited**

UNITED STATES PATENTS

2,369,233	2/1945	Hopkins.....	164/252 X
3,344,839	10/1967	Sunnen.....	164/52
3,550,259	12/1970	Smith.....	164/52 X
3,129,473	4/1964	Veil.....	164/252

2,709,842 6/1955 Findlay.....164/252

Primary Examiner—J. Spencer Overholser

Assistant Examiner—John E. Roethel

Attorney—McGlew and Toren

[57] **ABSTRACT**

A process for the production of a steel ingot of small cross sections comprises forming the ingot within the lower end of a mold which has a head portion which widens out in a conical configuration at its upper end and which carries in its conical portion a slag bath. A consuming electrode is dipped into the slag bath and it melts down in drops due to the passage of current and solidifies in the continuous casting mold at the top of the ingot. The electrode is moved at a speed such that it approaches the mold at a speed to remain immersed with its full cross section in the slag and so that the solid as well as the liquid parts of the ingot are present only in the lower part of the mold. The apparatus for carrying out this process includes a mold having a lower end of uniform cross section and an upper outwardly flaring conical end. The walls of the conical portion have an opening angle of between 60° and 120° and preferably 90° and this is sufficient to contain a slag bath to permit the electrode of a larger diameter than the ingot to be lowered into the bath with its full cross section.

1 Claim, 3 Drawing Figures

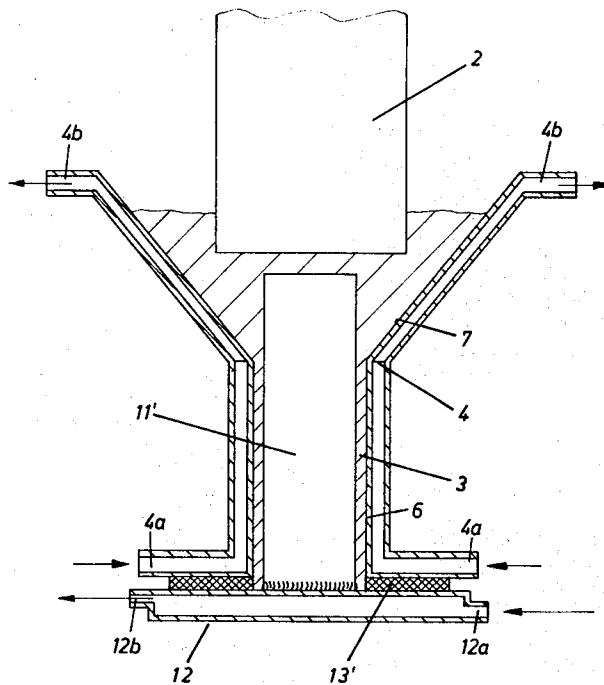

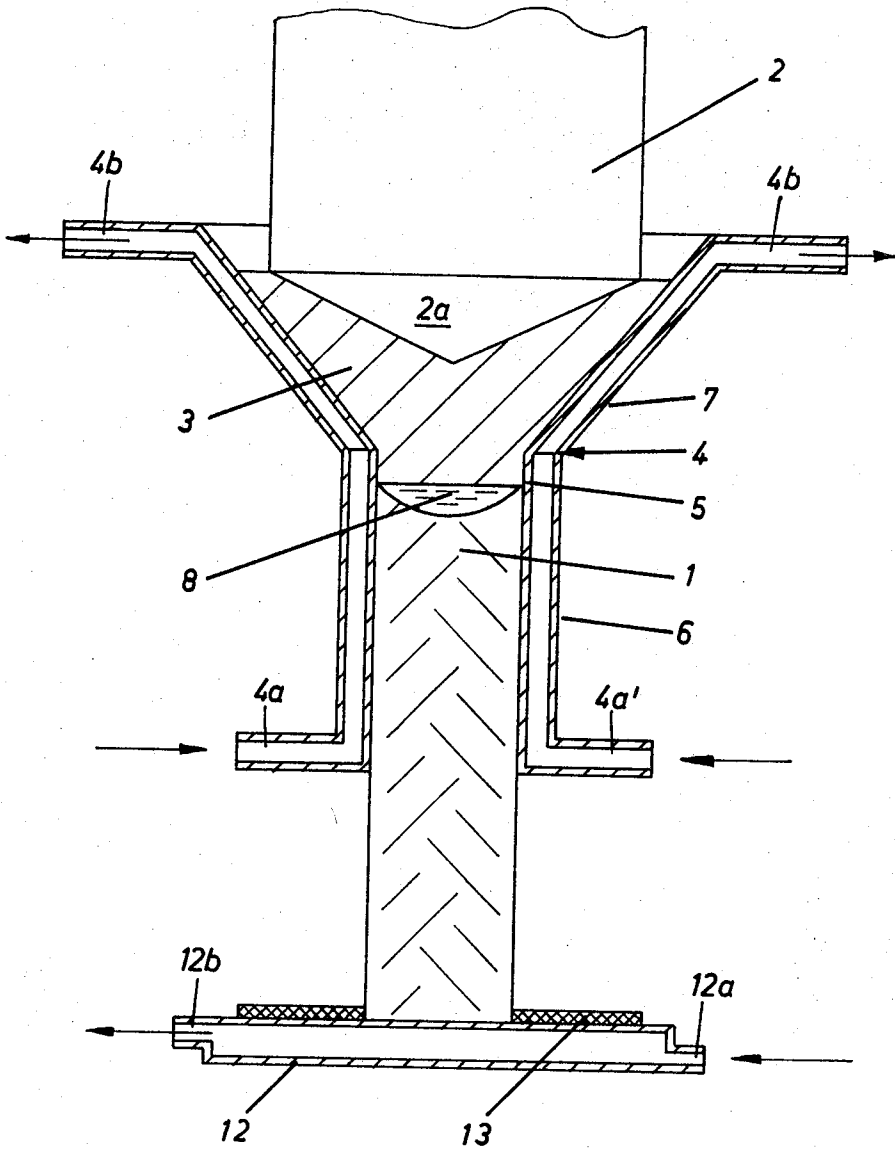

Fig.: 1

INVENTOR.
MANFRED WAHLSTER
BY ALOK CHOUDHURY
McGraw & Fox
ATTORNEYS

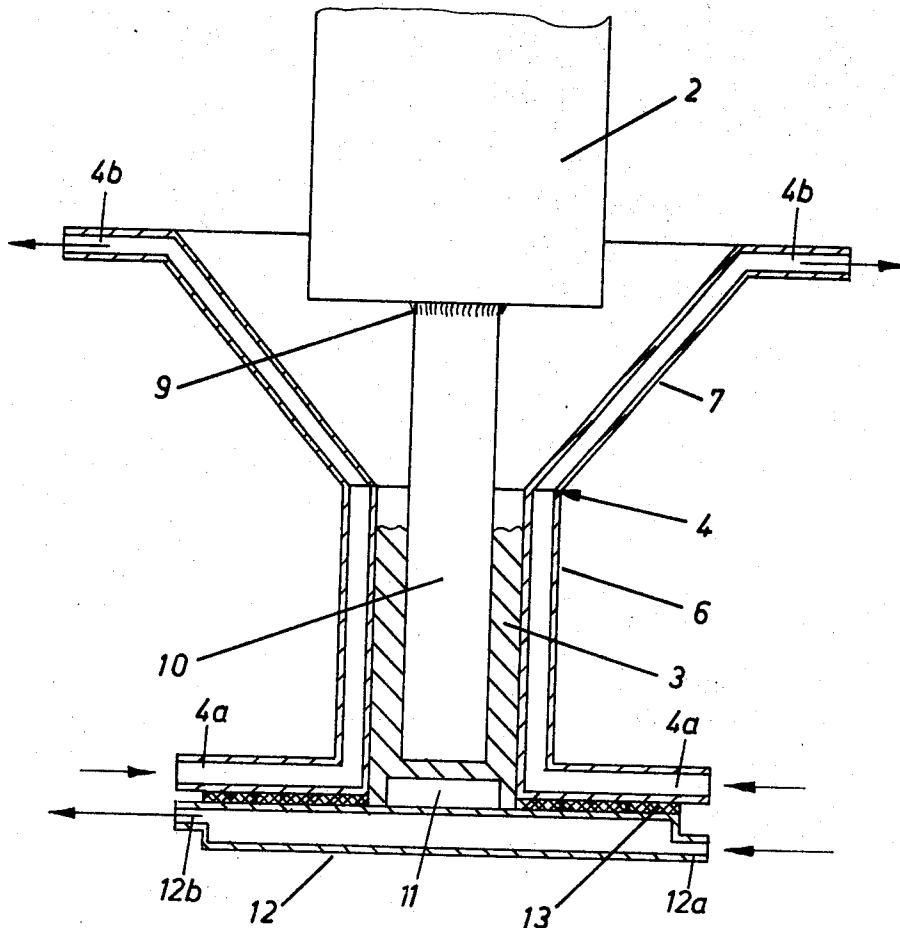

Fig.: 2

INVENTOR.
MANFRED WAHLSTER
BY ALOK CHOUDHURY
McGraw & Fore
ATTORNEYS

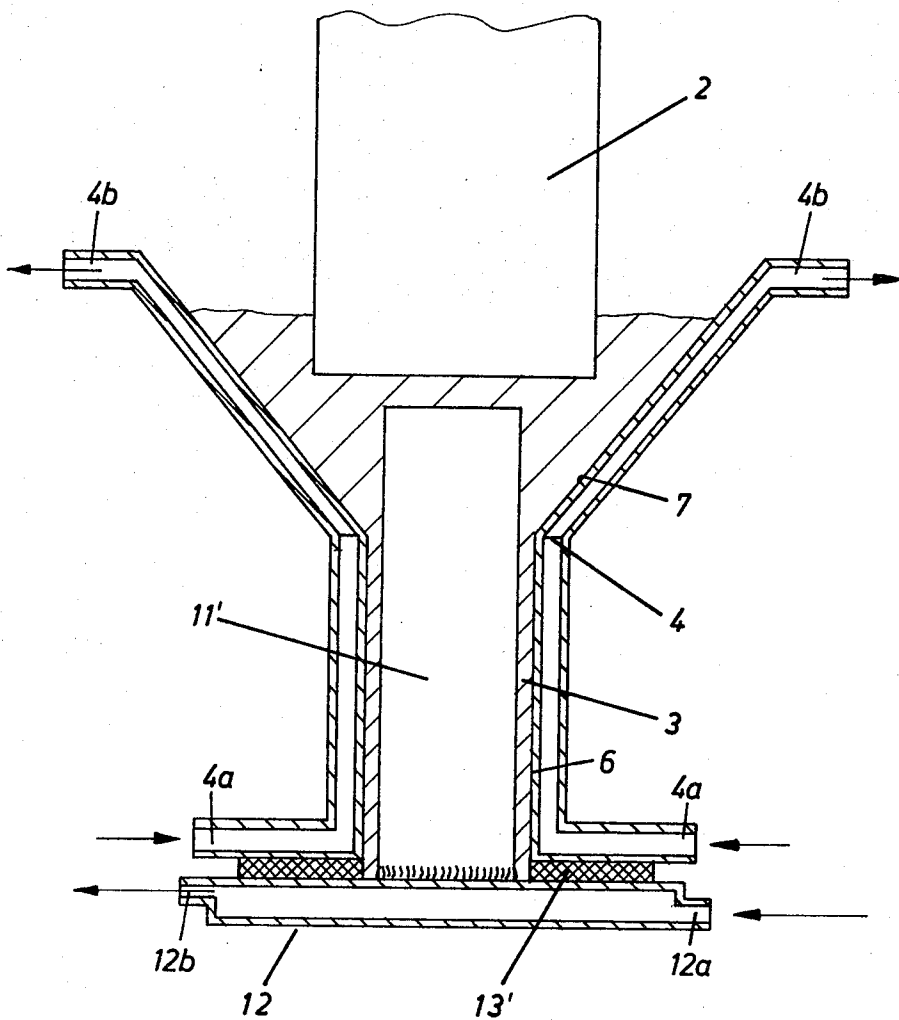

Fig.: 3

INVENTOR
MAFRED WAHLSTER
BY ALOK CHOUDHURY
M. S. S. & Pore
ATTORNEYS

PROCESS AND APPARATUS FOR PROVIDING STEEL INGOT

SUMMARY OF THE INVENTION

This invention relates in general to a metallurgical process and apparatus and in particular to a new and useful device for the production of steel ingot of small cross section by electrode slag remelting.

The invention is particularly applicable to the production of steel ingots of small cross section. In the known process of electro slag remelting, self consuming electrodes are melted in a water cooled mold which has a greater diameter than the electrode. The melting takes place by the passage of current between the electrode and a liquid slag into which the electrode is immersed and the ingot solidifies in the mold. The steel particles melted down from the electrode under the action of the passage of the current fall in the form of drops through the liquid slag bed and into the liquid pool in the head of the solidified ingot. Because the draw off of the solidified ingot is very slow compared with the continuous casting of the liquid steel, the liquid pool in the ingot head is very shallow and very pure ingots free from segregation and are formed. Because of the dense structure, the ingots produced in the electro slag remelt process require very little transformation to obtain a faultless material fit for technologically high grade purposes. It is inherent in the electro slag remelt process, however, that only ingots can be produced which have a diameter greater than the electrodes used for remelting. This leads to expensive reshaping of large ingots by rolling or forging and this is especially so for the production of objects of small cross sections such as axles, shafts or wires. Reduction of the cross section of the electrodes produced by casting merely shifts the shaping work from the remelted products, the ingot, to the product still to be remelted and will also lower the degree of utilization of the remelting plant.

An object of the present invention is to develop an economic process for the production of an ingot of small cross section. In accordance with the invention, the steel ingot is remelted by means of the electro slag remelting process, which is known in itself and from an electrode having a greater cross section than that of the ingot. The electrode immerses into a slag bath and melts down in drops due to the passage of current and then solidifies in a continuous casting mold which presents at the head of its lower part the same interior section as that of the ingot. The upper part of the continuous casting mold is widened in a funnel like a conical form to provide an area at least as great as that of the cross section of the electrode. The funnel is filled with slag to the extent that its surface corresponds at least to the full cross section of the electrode. The rate of approach of the melt electrode relative to the mold is so selected that the electrode immerses in the slag with its full cross section at all times and the rate of the lowering of the solidified ingot relative to the mold is so selected that the solid as well as the liquid parts of the ingot are present only in the lower part of the mold.

Accordingly, it is an object of the invention to provide an improved method for reproduction of a steel ingot of small cross section by remelting the ingot by electro slag remelting from a consumable electrode of a cross section which is larger than that of the ingot, comprising immersing the electrode in the slag bath and melting it down in drops by the passage of the current and solidifying the melted electrode in a continuous casting mold having a cross section comparable to that of the ingot and a widened head portion so that the cross section of the slag is at least as great as that of the electrode, and approaching the electrode to the mold at a rate of speed such that it immerses with its full cross section into the slag, and withdrawing the solidified ingot from the other end of the mold at a rate such that solid as well as liquid parts of the ingot are present only in the lower part of the mold.

Another object of the present invention is to provide a device for the continuous casting of an ingot of relatively small

cross section which includes a mold having a portion comparable to the cross section of the ingot to be formed and a widened upper conical portion for receiving a slag bath, with means for withdrawing the ingot from the lower end of the mold and for inserting a consumable electrode at a rate of speed to cause the melting thereof in the slag and the engagement of the entire cross section in the slag; the mold including means for cooling the formed ingot as it is withdrawn in order that the solid and liquid phase of the withdrawn ingot exists only at the lower part of the mold having the cross section of the ingot.

A further object of the invention is to provide a continuous cast mold which is simple in design, rugged in construction, and economical to manufacture.

The various features of novelty which characterize the invention are pointed out with particularity in the claims annexed to and forming a part of this specification. For a better understanding of the invention, its operating advantages and specific objects attained by its use, reference should be had to the accompanying drawings and descriptive matter in which there are illustrated and described preferred embodiments of the invention.

BRIEF DESCRIPTION OF THE PREFERRED EMBODIMENTS

In the drawings:

FIG. 1 is a schematic longitudinal section of a continuous casting mold constructed in accordance with the invention;

FIG. 2 is a view similar to FIG. 1 but indicating additions at the start up of the operation and before production is fully effected; and

FIG. 3 is a view similar to FIG. 2 of another arrangement for the starting up operation.

GENERAL DESCRIPTION OF THE PREFERRED EMBODIMENTS

Referring to the drawings in particular, the invention embodied therein, as indicated in FIG. 1, includes an apparatus and method for forming a continuous ingot 1 of relatively small cross section which is formed by the remelting from an electrode 2 of a larger cross section than that of the ingot by the electro slag remelt process. The electrode 2 is indicated in a production position in which its full cross section is immersed in a slag bath 3. The electrode 2 melts down and drops due to the evolution of heat upon the passage of current through the slag 3 and its solidifies in a continuous casting mold generally designated 4.

In accordance with the invention, the continuous casting mold 4 includes a lower part 6 having an interior cross section comparable to that of the ingot being formed and an upper part 7 which is of frusto-conical configuration and forms a widened funnel form at the top of the mold 4. In the production stage indicated at FIG. 1, the upper funnel part 7 is filled with the slag 3 to the extent that its surface is greater than the cross section of the electrode 2 so that the electrode 10 immerses with its full cross section into the slag.

During remelting the electrode 2 is lowered relative the mold 4 at a rate such that it is always immersed in the slag 3 with its full cross section. The ingot 1 is drawn off from the mold 4 at the lower end at such a rate that the liquid level of the pool 8 which is maintained at the head of the ingot 1 will be present in the lower part 6 of the mold 4. The relative movement of the electrode 2 and the ingot 1 in respect to the mold 4 can be achieved either by lowering the electrode 2 and the ingot 1 while the mold is retained in the stationary position or by a corresponding lifting of the mold 4 and the electrode 2 while the ingot 1 is retained relative to its surroundings.

During the starting up of the operation as indicated in FIG. 2, the electrode 2 is fitted with an electrode piece 10 of a smaller diameter than the electrode and of a diameter sufficient to permit it to enter into the lower part 6 of the mold 4. The electrode piece is melted down because of the current

generated in the slag bath 3 between the electrode 10 and a start up piece 11, and owing to this, the slag 3 will rise from the lower portion 6 into the upper funnel shaped part 7 of the mold until it reaches a state in which the complete cross section of the electrode 2 is immersed in the slag 3. At this point the process continues as outlined in FIG. 1.

The start up piece 11 is mounted on a water cooled bottom plate 12 having a diameter which is larger than the opening of the bottom part 6 of the mold 4. The mold 4 and the bottom plate 12 are cooled by the circulation of water through inlets 4a, 4a and 12a respectively and outlets 4b, 4b and 12b respectively. Material 13 forms a seal at the bottom of mold 4 during start up of the molding operation.

Another arrangement for the starting up operation is shown in FIG. 3. In this embodiment a relatively large start up piece 11' is positioned on the bottom plate 12 and sealed by the sealing material 13 to the bottom of the lower part 6 of the mold as in the other embodiments. In this arrangement the start up piece 11' has a diameter which is only slightly smaller than the interior diameter of the lower part 6 of the mold and the piece extends upwardly into the upper part 7 of the mold 4. With such an arrangement the slag 3 fills the lower part 6 around the circumference of the start up piece 11' and also extends up into the upper part 7 and encompasses the full cross section of the electrode 2.

In order to facilitate the drawing off of the ingot the lower part 6 of the mold 4 is made slightly conically widened toward its foot and starting from its cross section at the head 5 as shown in FIG. 1. The opening angle of the upper part 7 is in the example, illustrated 90°. This angle has proved appropriate because on the one hand it reliably prevents the adhesion of falling drops of melt material and collects them in the ingot head, and, on the other hand, at the upper portion 7 the cross section is sufficiently great for the remelting of very thick electrodes and this large cross section is attained without a very great structural height. For the removal of the heat of solidification the continuous casting mold is continuously cooled with the water and so is the bottom plate 12.

The process of the invention is carried out in the following manner:

To facilitate the starting up of the remelt process, the lower part of the electrode 2 is, at the beginning of remelting, provided with a welded on electrode piece of smaller cross section such as the electrode piece 10. This piece 10 is chosen so that its mass approximately fills the lower part 6 of the mold 4. In this manner the melted down electrode which does not fit through the lower part of the mold with its full cross section is brought into direct contact or into the vicinity of cooled start up section such as the start up section 11. This initiates the melting down process. An arc is directed through solid slag 3 between the electrode and the bottom plate 11 or the electric current flows through a liquid slag 3 without an arc. In addition, a so-called start up slag namely a slag conductive only in the solid state such as titanium oxide may be used. During the melting in of the welded on electrode section the slag is displaced from the lower part of the mold 4 into the funnel shape upper part 7 so that the electrode can dip into the slag with its greater diameter. Since the method of starting up occurs in the lower part of the mold any disturbances by formations of steel bridges which might interrupt the melting down process are avoided.

In the other embodiment of the start up operation, a start up piece whose diameter is of a slightly smaller diameter than that of the lower part of the mold 6 such as the piece 11' which fills a major portion of the lower part 6 and a portion of the upper part 7 of the mold 4. For the reliable avoidance of steel bridges the start up piece 11' may end below the head of the lower mold portion and the electrode may be tapered conically as shown at 2a in FIG. 1 at its front end or have an electrode piece of extension of smaller cross section secured to this front end such as a piece comparable to the piece 10. With this arrangement, the remelt process will start in the lower part 6 of the mold. Alternatively, the start up piece may

project into the upper part 7 of the mold so that the electrode need not be tapered at its lower end. Advantageously after the introduction of the start up piece the slag 3 is filled into the upper part 7 and the remelt process is initiated by current flow between the electrode 2 and the start up piece 11, across the slag. It is possible to operate with either solid slag through arc formation or with premolten liquid slag or with a start up slag.

Because of the conical enlargement of the lower portion 6 of the mold the ingots 1 can be drawn off downwardly with out difficulty and without imparting a vibrating movement between the mold and the ingot as in continuous casting. The reliable conduction of the drops which fall on the upper funnel shaped part 7 of the mold into the liquid pool 8 of the ingot head and the large ratio of the cross section of the electrode to the cross section of the ingot at small height of the upper part 7 of the mold is achieved by making the upper part in the conical form which has a cone opening of between 60° to 160° and preferably 90°.

The process of the invention makes it possible to melt ingots of small cross section from remelt electrodes 2 of very large diameter. This saves expensive shaping work in the rolling mill or in the forge which was inevitable for the production of small ingots which were carried out heretofore by the electro slag remelting process. With the present method excellent quality and the absence of pores can be obtained for such precision and end products as axles, shafts and wires. The slight residual shaping in the rolling mill which will be necessary after the process of the invention will be fully sufficient to ensure end products of equal technological quality as the end products which have been obtained by the known processes.

The invention will now be explained by way of several examples, it being understood however that these examples are given by way of illustrations and not by way of limitation and that many changes may be effected without affecting in any way the scope and spirit of the appended claims.

EXAMPLE 1

This test was carried out with an electrode having a diameter of 200 mm and a weight of 2.5 tons. Analysis of the electrode indicated the following composition

Cr:18.5%, Ni:11.0%, Mn:1.87%, Mo:0.26%, Si:0.54%, B:0.002%, S:0.012%, C:0.015%.

An ingot of 100 mm diameter was remelted from the electrode. The diameter of the lower portion of the mold was 100 mm while its length was 300 mm. The upper funnel-shaped enlarged portion of the mold had an opening angle of 90° and a height of 150 mm.

A starting piece of 60 mm diameter and a length of 810 mm and composed of the same material as that of the electrode was connected to the electrode prior to its remelting by welding. For the purpose of initiating the remelting, the mold was closed at its lower end by a water-cooled bottom plate with a short ignition disk of the same material as that of the starting piece. By lowering the electrode by means of a lifting device comprising block and tackle and a driving motor, the starting piece was brought into metallic contact with the ignition disk on the bottom plate. Thereafter 16.5 kg of slag in powder form and consisting of 70 percent of CaF₂ and 30 percent of Al₂O₃ where filled into the mold. The electrode and the bottom plate were connected with the clamps of a transformer. By slightly lifting the electrode and by switching on the transformer, a light arc was formed between the starting piece and the ignition disk. Under the action of this light arc, the slag in powder form was melted. The light arc was extinguished after three minutes and the partially liquid slag caused the further conduction of current.

The starting piece melted in about 10 minutes and its material filled the lower part of the mold. The larger portion of the slag was displaced in this manner into the funnel-shaped mold portion. 10 mm of the slag remained in the lower portion of the mold. After melting of the starting piece, the electrode dipped with its complete cross-section of 200 mm into the slag

bath which latter had at its surface a diameter of about 320 mm. The potential during the remelting amounted to 42 volts, while the current strength was 5500 A. The slag bath was maintained at a constant height of about 110 mm above the upper edge of the lower portion of the mold. This was accomplished by continuously adding slag. The remelting speed was 3.4 kg per minute. The lowering speed of the ingot was adjusted in such a manner that at any given moment 10 mm of slag remained in the lower cylindrical portion of the mold. This was done in order to prevent that the ingot would remain suspended by solidification in the upper funnel-shaped portion of the mold.

The entire remelting period for the ingot of 2.5 tons amounted to 730 minutes. The ingot thus produced was completely segregation free and had a perfect surface. The analysis of the ingot indicated the following composition:

Cr:18.5%, Ni:11.0%, Mn:1.8%, Mo:0.26%, Si:0.50%,
B:0.002%, S:0.005%, C:0.015%.

EXAMPLE 2

The test of Example 1 was repeated in another plant, wherein the lower portion of the mold was also 300 mm long and had a circular cross section of 100 mm. The opening angle of the upper portion of the mold, however, amounted to 120°. An ingot with 100 mm diameter was remelted from an electrode of 300 mm diameter. The starting of the procedure in this test was accomplished thereby that the bottom piece was rigidly connected with a water-cooled starting piece of 95 mm diameter and 400 mm length. The bottom piece with the starting piece connected thereto was introduced into the mold from below and projected into the upper, funnel-shaped portion of the mold. After the current connections of the transformer had been applied to the electrode and the bottom piece, the electrode was moved by means of a lifting device until contact with the starting piece was accomplished. The mold was then filled with 120 kg of slag in powder form and consisting of 70 percent of CaF_2 and 30 percent of Al_2O_3 , the slag reaching up into the funnel. The melting procedure was initiated by generating a light arc. The slag height in the funnel was maintained at about 200 mm by addition of slag. The voltage during the remelting amounted to 55 volt while the cur-

rent strength was about 8,500 ampere. The remelting speed amounted to 4 kg per minute. The entire remelting procedure for the 2.5 ton ingot lasted about 630 minutes. Starting and final analysis correspond to that of the preceding example.

5 While specific embodiments of the invention have been shown and described in detail to illustrate the application of the principles of the invention, it will be understood that the invention may be embodied otherwise without departing from such principles.

10 What is claimed is:

1. The process of producing a steel ingot of relatively reduced cross-section from a consumable electrode of relatively large cross-section in respect of that of said ingot, within a mold having a lower exit part with a cross-section corresponding approximately to that of said ingot for discharging from said mold, and having a feed-in part essentially frustoconical in shape with an uppermost end presenting a diameter larger than the diameter of said consumable electrode and that of said ingot; comprising, in combination, the 20 steps of arranging, at the beginning of the process, a start up piece forming the initial end of the ingot to be formed within the lower part of the mold, said start up piece being of a size such that it extends at its top end into the upper part of the mold and of a diameter such that it is only slightly smaller than 25 the lower part of the mold, starting electrode remelting by establishing a flow of electric current from said electrode to said start-up piece, subjecting the start-up piece to melting, directing the upper end of the ingot whose diameter is slightly smaller than that of the lower mold part toward the upper 30 mold part, producing slag within said mold parts to surround the ingot at least in the lower mold part, gradually filling said mold from its lower part through displacing the slag toward the upper mold part, thereafter advancing continuously the consumable electrode relative to the mold and within said slag 35 through said feed-in portion at a rate, so that said electrode remains with its entire cross-section immersed in said slag, while the ingot in formation is in said lower mold part, conditioning said lower mold part for solidifying said ingot therein, and withdrawing the ingot upon solidification and at a rate to 40 obtain liquid ingot parts, as well as a solid ingot only in said lower mold part.

* * * * *

45

50

55

60

65

70

75