



US 20060196651A1

(19) **United States**

(12) **Patent Application Publication**  
**Board et al.**

(10) **Pub. No.: US 2006/0196651 A1**

(43) **Pub. Date: Sep. 7, 2006**

(54) **OPTELECTRONIC DEVICES**

**Publication Classification**

(76) Inventors: **Kenneth Board**, West Glamorgan (GB); **Gareth Peter Evans**, West Glamorgan (GB); **Gareth Jones**, Pontyclun (GB)

(51) **Int. Cl.**  
**F28F 1/00** (2006.01)  
(52) **U.S. Cl.** ..... **165/177**

Correspondence Address:  
**PATTERSON, THUENTE, SKAAR & CHRISTENSEN, P.A.**  
**4800 IDS CENTER**  
**80 SOUTH 8TH STREET**  
**MINNEAPOLIS, MN 55402-2100 (US)**

(57) **ABSTRACT**

A light emitting semiconductor device mounted on a heat sink and having a heat pipe located on its upper surface. The heat pipe comprises a sealed cylindrical member of transparent or translucent material having a wick disposed down the side and along the bottom thereof. The heat pipe is partially filled with a liquid which is placed under a partial vacuum to reduce its boiling point. A bundle of optical fibres may be provided within the heat pipe, with the gaps created between the optical fibres providing an efficient capillary action within the heat pipe for transport of vapour to the cool end of the pipe and for transport of condensed coolant to the hot end of the pipe.

(21) Appl. No.: **10/517,907**

(22) PCT Filed: **Jun. 5, 2003**

(86) PCT No.: **PCT/GB03/02431**

(30) **Foreign Application Priority Data**

Jun. 13, 2002 (GB) ..... 0213504.4

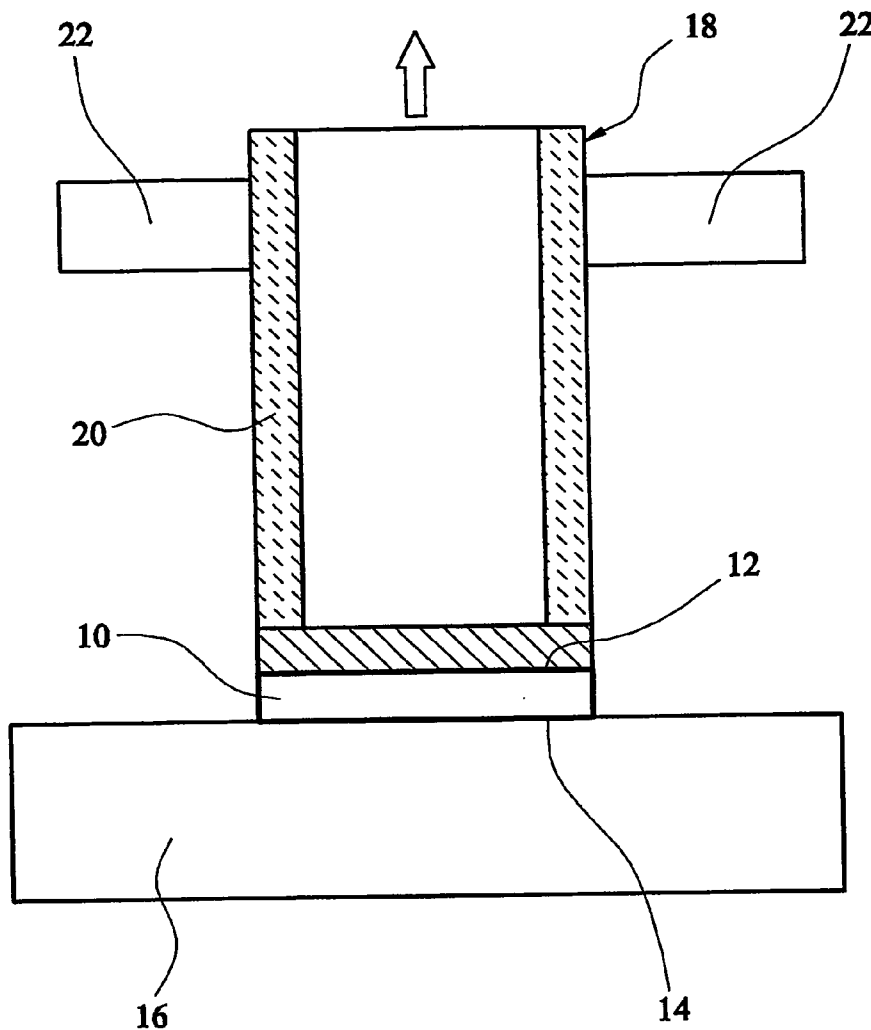

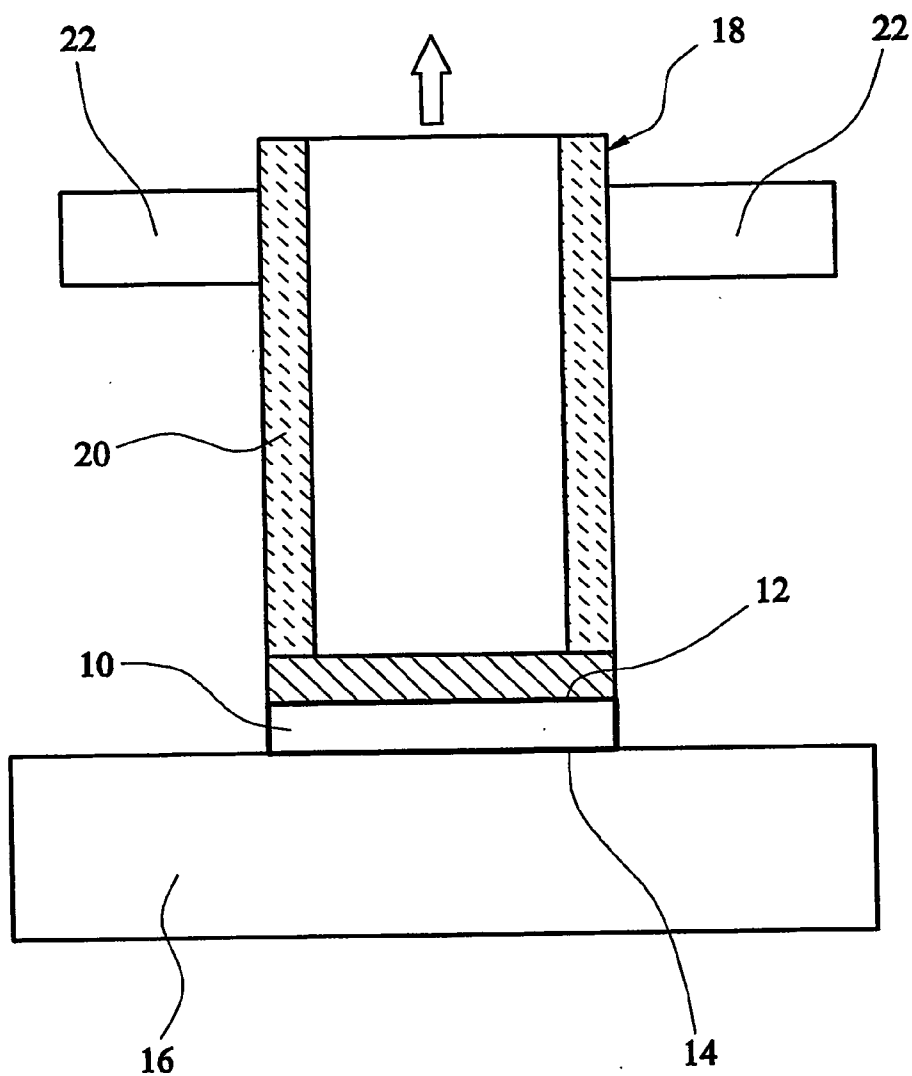

FIG. 1

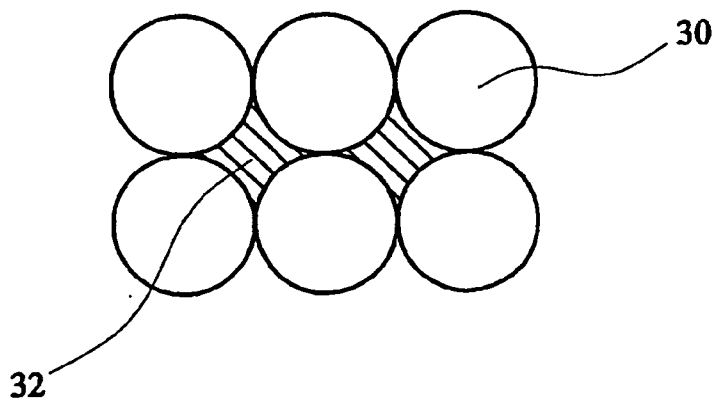

FIG. 2

### OPTEOELECTRONIC DEVICES

[0001] This invention relates to optoelectronic devices, such as light emitting diodes and other semiconductor light sources.

[0002] There are several known types of semiconductor light sources. For example, a p-n junction diode, when forward biased, can be made to emit visible light by application of an energy source, and is known as a light emitting diode or LED. The radiation has a broad spectrum and is spontaneous and non-coherent, and is due to the recombination of electrons and holes which occur when conduction band electrons are captured by valence band holes.

[0003] The production of light in semiconductor devices, such as an LED, usually requires an efficient optical system to provide for maximum extraction of light from the active region within the semiconductor, and it is well known to provide, for example, an optical coupling system consisting of a bundle of optical fibres, one end of which is placed in close proximity to the active region or light emitting surface of the device to extract light therefrom.

[0004] The efficiency and operation of such semiconductor light sources is adversely affected by an increase in temperature, i.e. it is desirable to maintain the temperature rise of the active device below a critical temperature. However, the application of an electrical energy source to the active device leads to an inevitable rise in temperature of that device. In other words, the physical process of light production is accompanied by the electrical energy which is dissipated as heat, and this heat must be removed effectively in order to avoid the device overheating which would result the efficiency of the light generation process being degraded and possibly the reduction of the operating lifetime of the device due to some heat-related failure mechanism.

[0005] It is well known to mount the active device on a heat sink formed of a highly thermally conductive material, such that heat flows down from the active device into the heat sink, thereby drawing unwanted heat away from the active device to cool it and maintain its temperature within design limits.

[0006] However, there are two primary disadvantages associated with this method of heat removal, which limit the amount of heat that may be safely removed from the active device. Firstly, the thermal resistance of the overall arrangement is relatively high because heat is required to flow from the active region of the device (which is generally provided at the upper surface of the device, through the substrate on which the active region is formed to the heat sink, the thermal conductivity of the substrate material generally being substantially lower than that of the heat sink material, which is usually copper. Secondly, the transient response is low (i.e. there is a considerable delay between the heat being generated and that heat being drawn away from the device). This low transient response is not only due to the above-mentioned relatively high thermal resistance, but also due to the high thermal capacities of the substrate and the heat sink in combination.

[0007] A cooling mechanism that has, in recent years, been introduced to the field of cooling semiconductor devices is the heat pipe. In a heat pipe heat may be applied at a localised area, or evaporator, where the working fluid in

the chamber is vaporised absorbing the latent heat of vaporisation. The vapour then flows due to a small pressure gradient, to the opposite side where it condenses and gives up the latent heat of vaporisation. A wick structure along the wall of the heat pipe provides capillary pumping for the liquid to return to the evaporator region thus completing the cycle. This phase change process will cause the condenser side to be nearly isothermal while spreading the energy from the heat source uniformly over the base of the heat sink. Heat pipes have superior heat transfer characteristics compared to more conventional heat removal arrangements, and have been found to be an excellent means to remove unwanted heat from semiconductor devices generally. However, known heat pipes are obviously not suitable for use on the light output side of semiconductor light sources, because they are opaque and would block the light output.

[0008] Thus, there are two primary considerations in respect of semiconductor light sources, that of efficient light extraction and that of effective heat removal from (or cooling of) the active device.

[0009] We have now devised an arrangement which overcomes the problems outlined above and achieves the object of the invention which is to provide a semiconductor light source in which efficient light extraction and effective heat removal is achieved. Thus in accordance with the present invention, there is provided a heat pipe for use in extracting heat from a semiconductor light source having an active region, the heat pipe comprising a transparent or translucent member of thermally conductive material and defining an optical transmission path therethrough, the heat pipe being adapted to be located proximate to the active region of the semiconductor device to extract heat, when in use.

[0010] The present invention extends to a semiconductor light source including an active region and having a heat pipe as defined above located proximate to said active region.

[0011] Thus, the heat pipe of the present invention is made of a transparent or translucent material, and has a refractive index or refractive index combination which facilitates the passage of light from the active region where it is generated.

[0012] The heat pipe of the present invention has a number of advantages. Firstly, the effective thermal conductivity of a heat pipe is very large and significantly greater than that of a copper (or similar) heat sink, such that temperature rises are substantially lower than in conventional semiconductor light sources. Secondly, the heat generated in the active region of the device can be removed directly from the surface that is emitting light, in addition (or as an alternative to) heat removal through the substrate. Thirdly, the transient response of the overall system including the heat pipe of the present invention is substantially improved because the heat transport function is dependent on the rate of vapour movement and not on the rate at which heat flows through the substrate and heat sink combination of the prior art. Finally, the heat pipe of the present invention has the significant advantage of permitting the passage of light therethrough such that it is suitable for use with a semiconductor light source.

[0013] The optical transmission path is preferably provided by means of a channel which runs through the heat pipe. In one preferred embodiment of the invention, the channel is arranged to receive optical transmission means.

[0014] The transparent or translucent member preferably comprises a hollow pipe (which can be any closed shape, not necessarily cylindrical) with sealed ends and is made of any suitable thermally conductive transparent or translucent material having the required mechanical strength for the application. A heat pipe is generally at least partially filled with a cooling fluid, such as water, deionised water, or any other suitable working fluid (which may be placed under a partial vacuum so as to lower the boiling point of the liquid). In use, the water in the end of the heat pipe which is closest to the active region is heated by the heat produced by the active region during operation of the device, until it is vaporised, at which point it rises to the cool side of the heat pipe (thus the heat is transported away from the active region as latent heat within the vapour), where it condenses and returns to the hot end of the heat pipe. The condensed liquid may be carried back to the hot end of the heat pipe by gravity. Alternatively or in addition, a wick or similar material which transports liquid by capillary action may be provided, in which case the condensed liquid is carried back to the hot end of the heat pipe by capillary forces in the wick.

[0015] In one preferred embodiment of the invention, the heat pipe defines a channel therethrough, in which is disposed a bundle of optical fibres or the like, said optical fibres being substantially circular in cross-section, the gaps between said optical fibres defining capillary channels by means of which heated coolant fluid (whether liquid or vaporised) can be transported towards the cool end of the heat pipe, and by means of which the condensed liquid can be transported from the cool end of the heat pipe back to the hot end (closest to the active region of the device). Thus, in one embodiment of the invention, a bundle of optical fibres placed in close proximity to the light emitting surface of a semiconductor light source would not only act as a light guide but, if made part of the heat pipe system, would allow (or at least aid) swift and effective heat removal when the coolant fluid (which is beneficially transparent) contained in the heat pipe is vaporised, and also return of the condensed fluid back to the cool end of the heat pipe. In another embodiment, a conventional wick structure of transparent material could be used.

[0016] An embodiment of the present invention will now be described by way of example only and with reference to the accompanying drawings, in which:

[0017] **FIG. 1** is a schematic diagram of a semiconductor light source including a heat pipe in accordance with the present invention; and

[0018] **FIG. 2** is a schematic diagram illustrating the capillary channels created between the fibres of a bundle of optical fibres for use in an exemplary embodiment of the present invention;

[0019] Referring to **FIG. 1** of the drawings, a semiconductor light source according to the invention comprises a light emitting semiconductor device **10** having an upper surface **12** that emits light and a lower surface **14**. The device **10** is mounted (at its lower surface **14**) on a heat sink **16**, made of, for example, copper or aluminium. Located on the upper surface **12** of the device **10** is a heat pipe **18** comprising a sealed member of transparent or translucent material having a wick **20** disposed down the sides and along the bottom thereof. The wick **20** may be of any suitable material capable of transporting liquid along it by means of a capillary action.

[0020] The heat pipe **18** is partially filled with a liquid (preferably transparent, such as water or deionised water or the like).

[0021] In use, light can be extracted from the active region of the device **10** via the heat pipe **18**, which is transparent (or at least translucent) in nature. At the same time, heat generated by the active region (because of the continuous or intermittent electrical energy applied thereto) is transmitted to the heat pipe **18** (via the upper surface **12** of the device **10**), which heats the liquid in the heat pipe **18**. The liquid is vaporised and rises toward the top of the heat pipe **18** (which is relatively cool), where it condenses and returns by means of gravity (and the wick **20**) to the lower (hot) end of the heat pipe **18**. In one embodiment of the present invention, a condenser **22** is provided at the upper (cool) end of the heat pipe **18** to speed up the process of condensing the coolant fluid within the heat pipe **18**. However, in another embodiment, heat may simply be removed by convection from the surface of the heat pipe.

[0022] Thus the heat pipe of the present invention provides an optical coupling system which also removes heat directly from the surface of the device close to the active region using a transparent heat pipe.

[0023] In a preferred embodiment of the present invention, and referring to **FIG. 2** of the drawings, a bundle of optical fibres **30** are provided within the heat pipe **18**. The optical fibres obviously provide a more efficient optical transmission means for extracting the light generated by the active region of the device **10**. However, in addition to this, the gaps **32** created between the optical fibres **30** in the bundle provide an efficient capillary action within the heat pipe **18** for transport of vapour to the cool end of the pipe **18** and (more importantly) for transport of condensed coolant to the hot end of the pipe **18**. It is well known that a geometry which provides efficient capillary action consists of one or more holes with sharp corners (the more acute the angles, the greater the capillary action), which is achieved naturally in the interstices between the substantially circular optical fibres **30**, as shown in **FIG. 2** of the drawings. It will be appreciated that the capillary forces acting in the gaps **32** will be relatively strong, provided that the dimensions are suitably small. The optical fibres **30** may be provided so as to substantially fill the channel defined by the pipe **18**, in which case cooling fluid may have to flow in both directions along the gaps **32** provided between the fibres. Alternatively, however, the fibres **30** may only partially fill the channel (they may, for example, be provided around the inner periphery of the pipe **18**, in which case a large gap is left through which vaporised cooling fluid can be rapidly and effectively transported away from the light emitting surface.

[0024] Embodiments of the present invention have been described above by way of examples only, and it will be apparent to a person skilled in the art that modifications and variations can be made to the described embodiments, without departing from the scope of the invention as defined by the appended claims.

1-14. (canceled)

15. A heat pipe for use in extracting heat from a semiconductor light source having an active region, the heat pipe comprising one of a transparent and translucent members said member formed of a thermally conductive material and defining an optical transmission path therethrough, the heat

pipe being adapted to be located proximate to the active region of the semiconductor device to extract heat, when in use.

**16.** A heat pipe according to claim 15 wherein said optical transmission path is provided by means of a channel which runs through the heat pipe.

**17.** A heat pipe according to claim 16, wherein said channel is arranged to receive optical transmission means.

**18.** A heat pipe according to claim 15, wherein the one of the transparent and translucent member comprises a hollow pipe with sealed ends.

**19.** A heat pipe according to claim 15, wherein the heat pipe is at least partially filled with a cooling fluid.

**20.** A heat pipe according to claim 19, wherein said cooling fluid is placed under a partial vacuum.

**21.** A heat pipe according to claim 15, which transports liquid by capillary action.

**22.** A heat pipe according to claim 16, wherein a bundle of optical fibres is disposed in said channel.

**23.** A heat pipe according to claim 17, wherein a bundle of optical fibres is disposed in said channel.

**24.** A heat pipe according to claim 23, comprising a cool end and a hot end, the hot end closer to the active region of the semiconductor device than the cool end, and wherein said optical fibres are substantially circular in cross-section, said optical fibers defining gaps between said optical fibres, said gaps defining capillary channels by which heated coolant fluid, said coolant fluid being in the state of at least one of liquid and vapor, can be transported towards the cool end of the heat pipe, and by which condensed liquid can be transported from the cool end of the heat pipe back to the hot end.

**25.** A heat pipe according to claim 24, wherein said optical fibres are located around the periphery of the heat pipe such

that a channel is defined through the centre of the pipe, by means of which coolant fluid can flow.

**26.** A semiconductor light source comprising a heat pipe according to claim 15.

**27.** A semiconductor light source according to claim 26, further comprising a condenser.

**28.** A combination heat pipe and semiconductor light source, the semiconductor light source having an active region, the heat pipe for use in extracting heat from the semiconductor light source, the heat pipe comprising a member formed of a thermally conductive material and defining an optical transmission path therethrough, the heat pipe being adapted to be located proximate to the active region of the semiconductor device to extract heat, when in use.

**29.** A combination heat pipe and semiconductor light source according to claim 28, wherein said optical transmission path is provided by means of a channel which runs through the heat pipe and wherein said channel is arranged to receive a bundle of optical fibers, and wherein the heat pipe has a coolant fluid therein.

**30.** A combination heat pipe and semiconductor light source according to claim 29, wherein the bundle of optical fibers defines a plurality of gaps and wherein the gaps define capillary channels for flow of the coolant fluid.

**31.** A combination heat pipe and semiconductor light source according to claim 15, wherein the heat pipe is at least partially filled with coolant fluid.

**32.** A method of cooling a light emitting diode having an active region, the method comprising the steps of placing a heat pipe as claimed in claim 15 proximate the active region.

\* \* \* \* \*