



(86) Date de dépôt PCT/PCT Filing Date: 2006/11/10
 (87) Date publication PCT/PCT Publication Date: 2007/05/31
 (85) Entrée phase nationale/National Entry: 2008/05/23
 (86) N° demande PCT/PCT Application No.: US 2006/060798
 (87) N° publication PCT/PCT Publication No.: 2007/062298
 (30) Priorités/Priorities: 2005/11/23 (US60/738,980);
 2006/02/15 (US60/773,344); 2006/06/15 (US11/452,920)

(51) Cl.Int./Int.Cl. *A61B 6/00* (2006.01)
 (71) Demandeur/Applicant:
 VITAL SENSORS, INC., US
 (72) Inventeurs/Inventors:
 BODECKER, VOLKER, DE;
 OSTERMEIER, MAX GEORG, DE;
 MEYER, STEFAN, DE;
 NIEMEYER, AXEL, DE
 (74) Agent: RICHES, MCKENZIE & HERBERT LLP

(54) Titre : DISPOSITIF IMPLANTABLE DE MESURE TELEMETRIQUE DE LA PRESSION
 ARTERIELLE/TEMPERATURE DANS LE COEUR

(54) Title: IMPLANTABLE DEVICE FOR TELEMETRIC MEASUREMENT OF BLOOD PRESSURE/TEMPERATURE
 WITHIN THE HEART

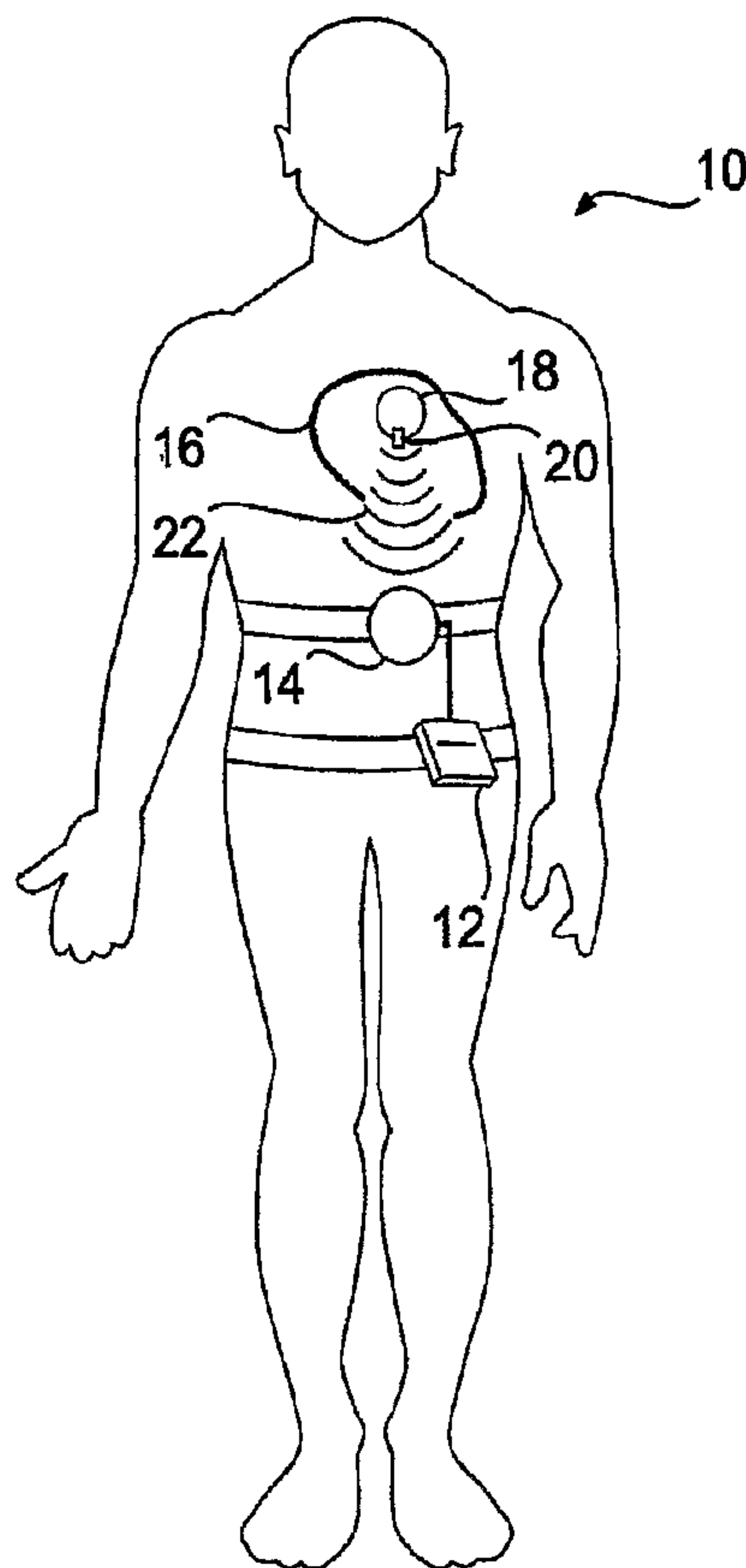

(57) **Abrégé/Abstract:**

A system and method for the intra corporal, telemetric measuring of blood pressure, particularly within the heart, includes a substantially rigid sensor chip mounted in a holder and an antenna. The holder is anchored within an appropriate location in the

(57) **Abrégé(suite)/Abstract(continued):**

cardiovascular system, such as in the cardiac septum, during surgery to position at least one capacitive pressure sensor on the chip in the blood flow to be sensed. Measured values are transmitted telemetrically from the chip to an extra corporal monitoring device.

(12) INTERNATIONAL APPLICATION PUBLISHED UNDER THE PATENT COOPERATION TREATY (PCT)

(19) World Intellectual Property Organization
International Bureau(43) International Publication Date
31 May 2007 (31.05.2007)

PCT

(10) International Publication Number
WO 2007/062298 A3

(51) International Patent Classification:

A61B 6/00 (2006.01)

(21) International Application Number:

PCT/US2006/060798

(22) International Filing Date:

10 November 2006 (10.11.2006)

(25) Filing Language:

English

(26) Publication Language:

English

(30) Priority Data:

60/738,980 23 November 2005 (23.11.2005) US

60/773,344 15 February 2006 (15.02.2006) US

11/452,920 15 June 2006 (15.06.2006) US

(71) Applicant (for all designated States except US): VITAL

SENSORS, INC. [US/US]; 800 E. Leigh Street, Richmond, VA 23219 (US).

(72) Inventors; and

(75) Inventors/Applicants (for US only): BODECKER,

Volker [DE/DE]; Vahrenwalder Str. 7, 30165 Hannover

(DE). OSTERMEIER, Max, Georg [DE/DE]; Vahrenwalder Str. 7, 30165 Hannover (DE). MEYER, Stefan [DE/DE]; Nordstrasse 41, 35236 Breidenbach (DE). NIEMEYER, Axel [DE/DE]; Wasserstrasse 19, 33605 Bielefeld (DE).

(74) Agents: KAMHOLZ, Scott, E et al.; Patent Group, Foley Hoag LLP, 155 Seaport Blvd, Boston, MA 02210-1450 (US).

(81) Designated States (unless otherwise indicated, for every kind of national protection available): AE, AG, AL, AM, AT, AU, AZ, BA, BB, BG, BR, BW, BY, BZ, CA, CH, CN, CO, CR, CU, CZ, DE, DK, DM, DZ, EC, EE, EG, ES, FI, GB, GD, GE, GH, GM, GT, HN, HR, HU, ID, IL, IN, IS, JP, KE, KG, KM, KN, KP, KR, KZ, LA, LC, LK, LR, LS, LT, LU, LV, LY, MA, MD, MG, MK, MN, MW, MX, MY, MZ, NA, NG, NI, NO, NZ, OM, PG, PH, PL, PT, RO, RS, RU, SC, SD, SE, SG, SK, SL, SM, SV, SY, TJ, TM, TN, TR, TT, TZ, UA, UG, US, UZ, VC, VN, ZA, ZM, ZW.

(84) Designated States (unless otherwise indicated, for every kind of regional protection available): ARIPO (BW, GH,

[Continued on next page]

(54) Title: IMPLANTABLE DEVICE FOR TELEMETRIC MEASUREMENT OF BLOOD PRESSURE/TEMPERATURE WITHIN THE HEART

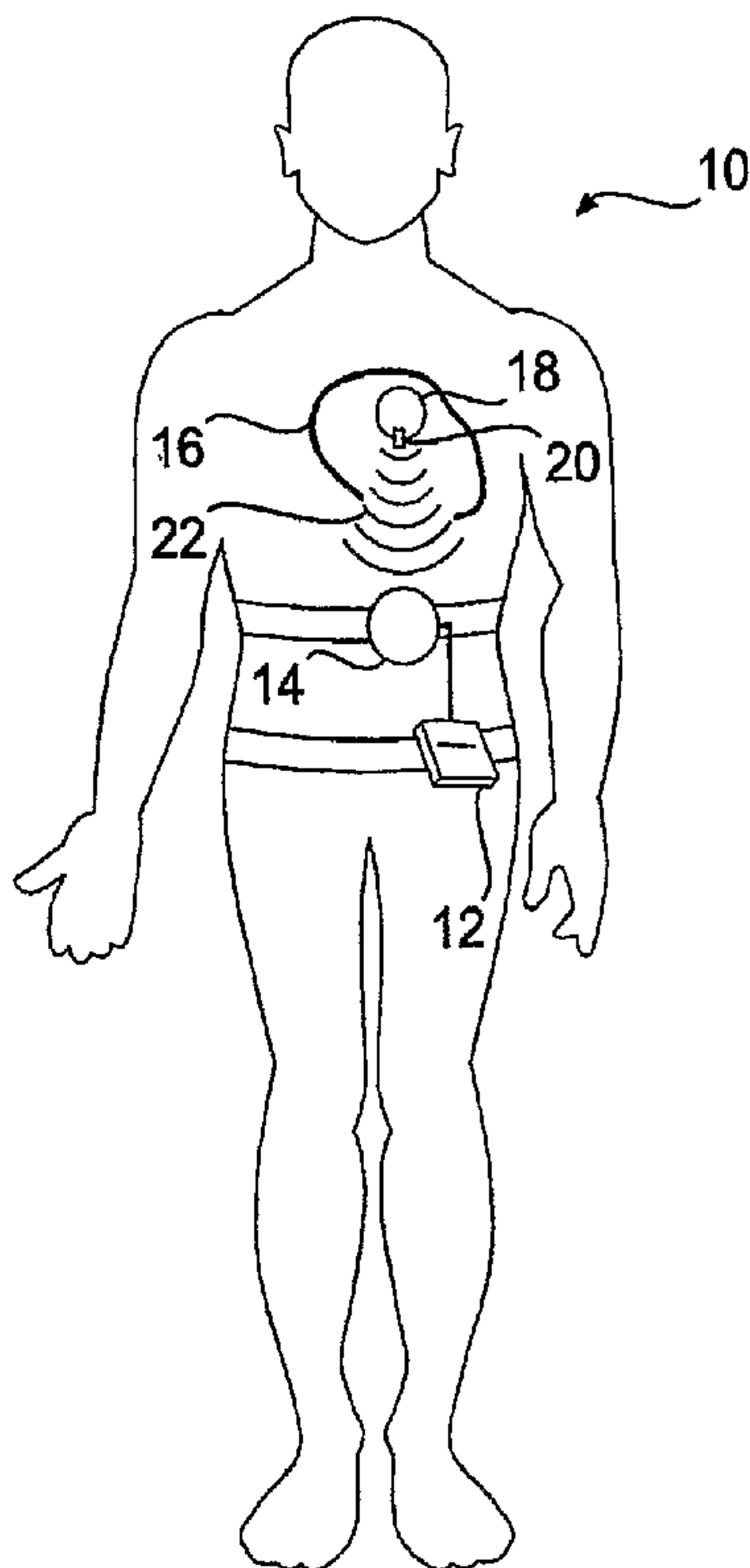

(57) Abstract: A system and method for the intra corporal, telemetric measuring of blood pressure, particularly within the heart, includes a substantially rigid sensor chip mounted in a holder and an antenna. The holder is anchored within an appropriate location in the cardiovascular system, such as in the cardiac septum, during surgery to position at least one capacitive pressure sensor on the chip in the blood flow to be sensed. Measured values are transmitted telemetrically from the chip to an extra corporal monitoring device.

WO 2007/062298 A3

WO 2007/062298 A3



GM, KE, LS, MW, MZ, NA, SD, SL, SZ, TZ, UG, ZM, ZW), Eurasian (AM, AZ, BY, KG, KZ, MD, RU, TJ, TM), European (AT, BE, BG, CH, CY, CZ, DE, DK, EE, ES, FI, FR, GB, GR, HU, IE, IS, IT, LT, LU, LV, MC, NL, PL, PT, RO, SE, SI, SK, TR), OAPI (BF, BJ, CF, CG, CI, CM, GA, GN, GQ, GW, ML, MR, NE, SN, TD, TG).

Published:

— *with international search report*

(88) Date of publication of the international search report:
6 March 2008

IMPLANTABLE DEVICE FOR TELEMETRIC MEASUREMENT OF BLOOD PRESSURE/TEMPERATURE WITHIN THE HEART

CROSS REFERENCE TO RELATED APPLICATIONS

This application claims priority under 35 U.S.C. §119(e) to provisional U.S. Patent
5 Application No. 60/738,980 filed on November 23, 2005, and provisional U.S. Patent
Application No. 60/773,344, filed on February 15, 2006, the disclosures of which are
herein expressly incorporated by reference in their entirety.

BACKGROUND OF THE INVENTION

10 Field of the Invention

The invention is directed generally to a method and apparatus and for sensing a
characteristic of a patient, such as blood pressure and/or temperature, and more
particularly to methods and devices particularly adapted for telemetric measurement of
blood pressure via a device implanted within the cardiovascular system during surgery
15 and particularly within the heart.

Related Art

The National Institute of Health (NIH) has concluded that heart failure constitutes
“a new epidemic” in the USA. Heart failure, a chronic, progressive and incurable disease,
affects over 20 million people worldwide. In the US alone, some 5 million people have
20 been diagnosed with heart failure. Heart failure is estimated to cost the US economy
today more than \$40 billion annually.

Intracardiac pressure management is an important aspect of heart failure
treatment. For example, a rise of the intracardiac pressure, such as in the left atrium is an
important early indication of disease progression and the first opportunity for therapeutic
25 intervention. Current blood pressure-measuring methods only can be applied in the
coronary care unit (CCU) or the intensive care unit (ICU) and provide no more than an
occasional snapshot of intracardiac pressure when the patient is already in a very critical
situation. The limitations on current intracardiac pressure measurement methods are a
serious impediment to early and optimal treatment. Current treatment methods require
30 hospitalization and may be extremely costly (on average, over \$16,000 per patient
admittance). The ability to monitor patients and intervene outside of the hospital setting
would greatly reduce the number of hospitalizations and extend the lives of those affected
by the diagnosis.

Various sensors and devices have been used or proposed for the measurement and analysis of the blood pressure and/or temperature of a patient with mixed success. The currently contemplated sensors have certain disadvantages. For example, the telemetric sensor described in U.S. Patent No. 6,855,115 can be implanted in the heart by
5 a catheter and is not designed for surgical implantation. Moreover, the sensor, which is rolled up during the implantation procedure, must be made of a flexible material of a specific configuration so that any change of the blood pressure inside the heart effectuates a change in the distance of the sensor height, *i.e.*, the distance between the two capacitor plates used in the sensor. This flexible sensor is folded for delivery via a
10 catheter and then unfolded at the place of implantation. However, a disadvantage of such a configuration is its required flexibility as constant and precise acquisition of measurement data may not be possible when the sensor is placed on or close to the cardiac muscle, and therefore is exposed to the cardiac motions, which may influence correct pressure readings. In addition, the flexible material of a sensor made in
15 accordance with U.S. Patent No. 6,855,115 may deform due to exposure to constantly streaming liquids, especially a turbulent blood stream likely encountered inside the heart. As a consequence, the capacitance of the capacitor may be changed and measurement values may deteriorate and/or deviate from the true value. Another disadvantage of this type of sensor is due to its use of a pressure-dependent LC-oscillator. The resonant
20 frequency of this oscillator can be analyzed telemetrically. In principle, this kind of device can be applied to measure the pressure that affects the measurement capacitor. Thus, any damage to the material can affect the pressure measurements obtained. Further, as the sensor is influenced by the surrounding media of the sensor, a corruption of measurement values may occur. In addition, there is no circuitry in this type of sensor to
25 digitize the pressure measurement values acquired. Using analog signals may result in external interference during the acquisition and transmission of data, which causes inaccuracies in readings.

Another exemplary implantable device, described in US Patent No. 6,409,674, uses a catheter filled with a pressure transmitting fluid or gel-like material. The catheter
30 transmits pressure to a pressure transducer within a housing. The sensed pressure is then telemetrically transmitted to an external reader. However, such a device requires a housing for the electronic signal processing circuitry, which results in a larger and heavier sensor structure that can cause strain on the heart when implanted into a heart wall. Moreover, the catheter and housing configuration creates a more complicated,
35 mechanical structure that may be at increased risk for mechanical failure, and therefore is not suitable for long term implantation.

Another device, described in US Patent No. 6,970,742, has a pressure sensor placed within the heart. A signal from the pressure sensor is transmitted to a housing outside the heart which contains the electronic processing circuits. The signal is processed by the electronic processing circuits, such as converting the signals from analog to digital, and then telemetrically transmitted to an external reader. However, housing the electronic processing circuitry requires additional components and a relatively larger implanted device. Moreover, because digitization of the signal does not occur until outside of the heart, there is a risk of interference in the wire connecting the sensor and the electronic processing circuitry, as analog interference may result from external sources.

Small pressure sensor chips including the electronic processing circuits have been used in other applications. For example, integrated chips having pressure sensors have been used for pressure measurement in optical and cranial applications. These sensors are compact and have fewer mechanical components. Examples of such pressure sensor chips are described in EP 1 312 302 A2 and German patent application DE 10 2004 005 220.7, of which the inventors of the present invention were involved. However, these integrated chips are used in a relatively stable environment, with little movement in the fluids of the eye or brain. Nor are these pressure sensors subject to the cyclical, dynamic movements found in the heart. Such movement may harm connections, such as connections between wires and the pressure sensing chip. Thus, the use of such pressure sensor chips is not suited for the environment of the heart, where there is cyclical and dynamic movement, and where there is continuous and turbulent fluid movement around the pressure sensor.

Conventional techniques to provide stability and support to such known pressure sensing chips to enable their use as a cardiovascular pressure sensors would not likely succeed. Directly attaching a wire to a pressure sensing chip may have a negative impact on the functionality of the chip. For example, when soldering is used for the connection, the heat may damage the chip. One known method of avoiding that problem is to adhere a substrate to the back of the pressure sensing chip, solder the wire to a bond tack on that substrate, and then connect the wire to the chip. However, such substrates have different coefficients of thermal expansion than the chip. Thus, as the temperature changes, the substrate expands and contracts at a different rate than the pressure sensor chip, thereby causing stress and strain on the pressure sensing chip and increasing the risk of damage and/or inoperability.

Other known pressure sensors require a cable connection between the pressure sensor inside the heart and the external body monitoring device. However, such a cable

clearly requires an entry into the body. An entry may be inconvenient and require the implantation of both the device and the entry, as well as increase the risk of infection for the patient.

Thus, there is a need for intra-cardiac pressure sensors that are more reliable and accurate, and which cause less irritation when implanted in the heart and are more compatible with the dynamic conditions encountered in a moving heart. Also, a need exists for such a sensor to be used at other locations within the cardiovascular system with little or no modifications.

10

SUMMARY OF THE INVENTION

The invention meets the above needs and avoids the disadvantages and drawbacks of the prior art by providing a substantially rigid, chip-based telemetric sensor and system in which an extremely small and lightweight chip, including at least one pressure sensor and all necessary electrical circuitry, may be implanted into the heart or other portion of the cardiovascular system during surgery, to monitor blood pressure and/or temperature.

In this manner, pressure signals may be digitized at or near the sensing location in the heart or other location in the cardiovascular system and data may be telemetrically directed to the place of data acquisition to reduce or eliminate data transmission interference from external sources.

In particular, the chip may be a substantially rigid structure that provides improved durability, long term stability, and long term accuracy, and resistance to damage or a change in membrane characteristics from the blood flow due to turbulences and the like within the bloodstream. For example, the chip may be an application specific integrated chip (ASIC) containing all the necessary sensing elements and digital signal processing electronics. The ASIC preferably is very small and lightweight to avoid undue stress on the heart and is orientated within the body in a position to minimize turbulent flow and reactionary forces. The ASIC may be used with an antenna in the form of a coil created with very small dimensions. This minimal configuration of ASIC and coil may reduce and/or eliminate mechanical tensions effecting the connection between ASIC and a coil.

The ASIC and the coil may be electrically and physically connected by a flexible coil. The ASIC, cable and coil may be encapsulated within a seamless biocompatible and flexible sheathing, such as silicone or similar material, to form an integrated sensor unit. The seamless sheathing may maintain the integrity of the sensor by reducing or eliminating the exposure of the sensor to body fluids, such as blood. It may also be shaped and/or orientated to reduce turbulent flow.

A liquid or gel may be placed between the pressure sensing elements, such as capacitive membrane sensors of the sensor and the sheathing, to reduce or eliminate the effects of endothelialization on the surface of the sensor. The liquid or gel allows for integrating the pressure across the entire area of pressure sensing portion of the sensor to minimize the effects of localized plaque or endothelialization. The sheathing material itself may act as a pressure transmitting material instead of the liquid or gel. Of course, heparin and other preventative coatings known in the art also may be used to prevent or reduce endothelialization.

To protect the ASIC and particularly the membrane sensor elements from damage due to handling, e.g., as a consequence of contact with a surgical instrument during implantation and/or during use, the sensor design may have a unique geometry. For example, the ASIC may be connected to a substantially rigid substrate in a spaced apart relationship from the ASIC such that the substrate is opposite the pressure sensing elements of the sensor chip, with an aperture in the substrate providing access to the pressure elements to expose them to fluid pressure to be sensed. A silicone or other similar flexible material may be disposed between the ASIC and the substrate. Moreover, a pressure transmitting material may be placed within the gap between the ASIC and the rigid substrate so that pressure from the blood can be transmitted to the pressure elements via the material.

The ASIC may incorporate a robust system to compensate for drift due to the age and use of the sensor. For example, the ASIC may include inactive pressure sensing elements that determine the change in the measurement in the sensor due to age and usage, and may account for this change when active pressure sensing elements determine the pressure.

The ASIC may be supported in a holder particularly adapted for anchoring the ASIC in a wall of the heart or other location in the cardiovascular system. The holder may include a stop to position the ASIC and limit its movement.

The ASIC is powered by induction from a wireless signal from an external reader, thereby avoiding the need for an internal power source. Use of a transponder power supply at the external reader allows for a substantially rigid sensor device with a longer life. The external reader provides power to the substantially rigid sensor and receives pressure and temperature information from the substantially rigid sensor. The external reader stores and displays measurement and parameter data, calculates certain values. The external reader stores and displays measurement and parameter data, and may transmit the data to a computer or other device for further processing. The external

reader may have a separate antenna coil to facilitate prolonged periods on a patient's body. The external reader may store one or more calibration curves for different sensors.

The telemetric pressure and/or temperature sensor of the invention may be used for continuous or on demand sensing. A specific identification number may be transmitted
5 with each single measurement or measurement cycle. In this way, a continuous measurement value and sensor identification, and therefore the measurement value and the identity of the patient, is provided. The identification number may allow a single external reader to receive data from multiple sensors and systems and to assign them to the correct calibration curve for that sensor system and the patient.

10 The invention may be implemented in a number of ways. According to one aspect of the invention an intra-cardiac pressure measuring system for measuring blood pressure inside the heart of a patient includes an antenna and an integrated chip. The integrated chip may include a first substantially rigid substrate, at least one pressure sensor disposed within the substrate to generate signals indicative of a sensed pressure, and
15 electronic signal processing components to process the signals generated by the at least one pressure sensor. The electronic signal processing components may be operatively connected to the antenna and the integrated chip may be powered by a signal received at the antenna. An implantable holder may support the integrated chip and include an anchor structure to mount the integrated chip within a wall of the heart during surgery
20 such that the at least one pressure sensor is exposed to blood flow in the heart. The system may also include a remote receiver, wherein the integrated chip is operative to send digital signals indicative of the pressure sensed in the heart telemetrically via the antenna to the remote receiver.

The at least one pressure sensor may be capacitive-based pressure sensitive
25 membranes housed within the substrate. The at least one pressure sensor may generate an analog signal in response to a sensed pressure and the electronic signal processing components may include at least one analog to digital (A/D) converter to digitize within the heart the analog signals from the at least one pressure sensor. The system may further include a flexible wire connecting the antenna and the integrated circuit, with the antenna
30 being configured to be implanted within the patient underneath the skin to facilitate telemetric data transmission to the receiver. The integrated chip may weigh less than about one gram, have a surface area on one side of less than or equal to about 10 mm² and have a thickness of less than about 1 mm.

The antenna, the chip, wire and holder may be encapsulated in a seamless, one-
35 piece biocompatible sheathing. A pressure transferring medium may be interposed between the biocompatible sheathing and the at least one pressure sensor. The

biocompatible sheathing may act as the pressure transferring medium, and may be shaped to minimize turbulence in blood flow within the heart. The integrated chip may further include a unique digital identification, which is sent telemetrically to the receiver. The receiver may obtain calibration information associated with the integrated chip based
5 on the unique digital identification. The receiver may include a stored parameter and produce an alert based on the signals indicative of the pressure sensed in the heart and of the stored parameter.

The system may further include a second substantially rigid substrate located opposite the at least one pressure sensor in the first substrate and in a spaced apart
10 configuration to protect the chip from mechanical damage. The second substrate may include an aperture permitting blood flow within the heart to act on the at least one pressure one pressure sensor. A pressure transferring medium may be interposed between the at least one pressure sensor and the second substantially rigid substrate to transfer blood pressure to the at least one pressure sensor. At least one bond pad may
15 be disposed between the first and second substantially rigid substrates and electrically connected to the integrated chip. At least one bond tack may be provided on the second substantially rigid substrate and be connected to the at least one bond pad such that the antenna is operatively connected to the integrated chip via the at least one bond pad and the at least one bond tack to provide a strain relief connection. An antenna connector
20 may connect the antenna to the second substantially rigid substrate, wherein the antenna connector includes a signal portion electrically connecting the antenna to the integrated chip and a support portion connected to the second substantially rigid substrate. The antenna connector may be attached to the second substantially rigid substrate such that there is slack in the signal portion when the support portion is taut. The signal portion
25 may be connected to the integrated chip via the at least one bond tack and the support portion may be connected to the second substantially rigid substrate via an opening in the second substantially rigid substrate. The at least one bond tack may include at least two bond tacks disposed on opposite sides of the aperture. The second substantially rigid substrate may include a protective barrier connected thereto, and a biocompatible
30 sheathing may encapsulate at least the integrated chip and the second substantially rigid substrate. The protective barrier prevents the first substantially rigid substrate from puncturing the biocompatible sheathing. A flexible support material may be provided between the integrated chip and the second substantially rigid substrate.

The holder and the first substantially rigid substrate may be integrally formed into a
35 single piece. The antenna may be supported by said holder. The holder may include a stop that limits the movement of the integrated chip into the heart chamber. The

integrated chip and the holder may be removable from the heart after implantation. The at least one pressure sensor may include a plurality of pressure sensors including at least one active sensor responsive to changes in pressure within the heart and at least one passive sensor that is isolated from the changes in pressure within the heart, and the electronic signal processing components may provide a signal based at least in part on a signal from the at least one active pressure sensor and a signal from the at least one passive pressure sensor. The structure of the active pressure sensor may be substantially the same as a structure of the passive pressure sensor. The plurality of pressure sensors may include capacitive pressure sensors each having a flexible movable membrane. The passive pressure sensor signal may be responsive to a change in position of the membrane of the passive pressure sensor, which is due to a drift effect comprising a sag of said membrane. The change of position of the membrane of the active pressure sensor may be due to a change in pressure within the heart and a drift effect comprising a sag of the membrane. The pressure signals may be the result of offsetting the signal from the at least one active pressure sensor with the signal from the at least one passive pressure sensor.

According to another aspect of the invention a method of sensing blood pressure within the cardiovascular system of a subject includes the steps of (a) implanting within the subject an integrated chip including a substantially rigid substrate and at least one capacitive-based pressure sensor disposed within said substrate in a position to sense blood pressure within the cardiovascular system; (b) powering on the integrated chip telemetrically by activating a power source located outside the subject; (c) obtaining one or more analog signals from the at least one pressure sensor indicative of the pressure at the position in the cardiovascular system; and (d) converting the analog signals to digital signals at or directly adjacent to the position in the cardiovascular system where the sensing occurs.

The implanting step may include implanting an ASIC having a capacitive-based pressure sensor in the heart. The method may further include the step of limiting the ASIC from entering the heart chamber with a stop device. The integrated chip may include a unique digital identification, and the method may include the step of telemetrically communicating the unique digital identification to an external reader. The method may further include the step of obtaining calibration information associated with the integrated chip at the external reader based on the unique digital identification. The integrated chip may be supported in a holder and the implanting step may include the steps of delivering the holder to the position in the cardiovascular system, and mounting

the holder at the position such that the at least one pressure sensor is exposed to the pressure in the cardiovascular system to be sensed.

The at least one capacitive-based pressure sensor may include a plurality of capacitive-based pressure sensors including an active pressure sensor and a passive pressure sensor located within the subject in a position to directly sense blood-pressure within a position in the cardiovascular system, and the step of obtaining one or more analog signals may further include obtaining one or more analog signals from the active pressure sensor indicative of the pressure at the position in the cardiovascular system, obtaining one or more analog signals from the passive pressure sensor indicative of the pressure at the position in the cardiovascular system, and generating one or more combined analog signals based on the one or more analog signals from the active pressure sensor and the one or more analog signals from the passive pressure sensor indicative of the pressure at the position in the cardiovascular system. The step of converting the analog signals may further include converting the combined analog signals to digital signals. The step of generating the one or more combined analog signals may include offsetting the signal from said active pressure sensor with the signal from said passive pressure sensor.

In yet another aspect of the invention an integrated chip for intra-cardiac blood pressure measurement inside the heart of a patient includes a first substantially rigid substrate, at least one pressure sensor disposed within the substrate to generate signals indicative of a sensed pressure, and electronic signal processing components to process the signals generated by the at least one pressure sensor. The electronic signal processing components may be operatively connected to an antenna, and the integrated chip may be powered by a signal received at the antenna. The integrated chip is operative to send digital signals indicative of the pressure sensed in the heart telemetrically via an antenna to a remote receiver.

The at least one pressure sensor may generate analog signals and the electronic signal processing components may include at least one analog to digital (A/D) converter to digitize within the heart the analog signals from the at least one pressure sensor. The integrated chip may weigh less than about one gram, have a surface area on one side of less than or equal to about 10 mm² and have a thickness of less than about 1 mm. The integrated chip may further include a second substantially rigid substrate located opposite the at least one pressure sensor in the first substrate and in a spaced apart configuration. The second substrate may include an aperture permitting blood pressure within the heart to act on the at least one pressure one pressure sensor. The integrated chip may also include a pressure transferring medium interposed between the at least one pressure

sensor and the second substantially rigid substrate to transfer blood pressure to the at least one pressure sensor.

Additional features, advantages, and embodiments of the invention may be set forth or apparent from consideration of the following detailed description, drawings, and
5 claims. Moreover, it is to be understood that both the foregoing summary of the invention and the following detailed description are exemplary and intended to provide further explanation without limiting the scope of the invention as claimed.

BRIEF DESCRIPTION OF THE DRAWINGS

10 The accompanying drawings, which are included to provide a further understanding of the invention, are incorporated in and constitute a part of this specification, illustrate embodiments of the invention and together with the detailed description serve to explain the principles of the invention. No attempt is made to show structural details of the invention in more detail than may be necessary for a fundamental
15 understanding of the invention and the various ways in which it may be practiced. In the drawings:

Figure 1 schematically illustrates an embodiment of an implantable telemetric measuring device and reader constructed according to principles of the invention providing for continuous or regular intra-cardiac pressure monitoring;

20 Figure 2 schematically illustrates another embodiment of an implantable telemetric measuring device and reader constructed according to principles of the invention providing for on-demand intra-cardiac pressure monitor monitoring;

Figure 3 illustrates a cross-sectional view of the heart area of a patient where the implanted device of the invention may be employed, including the left and right atrium and
25 the crossing of veins at the posterior septum;

Figure 4 illustrates a greatly enlarged, plan view of a substantially rigid ASIC constructed according to principles of the invention for sensing intra-cardiac pressure and temperature including active and passive, capacitive membrane sensing elements and on-chip electronics for digital signal processing and telemetrical power supply.

30 Figure 5 is an enlarged, cross-sectional view of the ASIC of the invention showing some of the active pressure sensors and passive pressure sensors;

Figure 6 is an enlarged, cross-sectional view of the ASIC of the invention showing a pressure transmitting gel or fluid between a sheathing and the active pressure sensors;

Figures 7 and 8 schematically illustrate a cross-sectional and top plan view,
35 respectively, of one embodiment of an implantable sensor device of the invention

including a substantially rigid ASIC connected at two ends to a substantially rigid substrate having a cut out;

Figures 9 and 10 schematically illustrate a cross-sectional and top plan view, respectively, of another embodiment of an implantable sensor device of the invention including a substantially rigid ASIC connected at one end to a substrate having a cut out;

Figure 11 is a perspective illustration of the implantable device of Figures 7 and 8 or 9 and 10, showing an electrical wire and filament core connection between the ASIC and the antenna;

Figure 12 illustrates a perspective view of the implantable sensor device of the invention with a cut out located at an edge of the substrate,

Figure 13 is a perspective view showing the electrical wire and filament core connection of the Figure 12 embodiment;

Figure 14 is a cross-sectional view that schematically illustrates the electrical wire and filament core connection to a substrate of the invention;

Figures 15 and 16 schematically illustrate yet another embodiment of an implantable sensor device of the invention having a cut out located at an edge of the substantially rigid substrate and a protective barrier wall located at one end;

Figure 17 schematically illustrates a cross section view of a further embodiment of the protective barrier wall of the invention;

Figure 18 schematically illustrates an integrally formed ASIC and holder of the invention implanted in a wall of the heart during surgery;

Figure 19 schematically illustrates another integral ASIC and holder of the invention having a "T"-shaped anchor implanted in a wall of the heart during surgery;

Figure 20 schematically illustrates an ASIC and separately formed holder of the invention in the form of an elbow connector holding the ASIC and guiding a slack portion of the connecting wire;

Figure 21 is a three-dimensional representation of a holder of the invention that mounts the ASIC in the wall of the heart and includes suture wings that limit movement of the ASIC and serve as suture mounts;

Figure 22 is a three-dimensional representation of another embodiment of a holder of the invention where the holder includes an end cap;

Figure 23 is a three-dimensional representation of a holder of the invention illustrating how it connects the ASIC via a flexible cable to an antenna;

Figure 24 schematically illustrates an implantable sensor device of the invention encased in a biocompatible sheathing;

Figure 25 is a side view of the device illustrated in Figure 24 illustrating how the shape of the sensor may be configured as a football shape to minimize turbulence and reactionary fluid forces in the heart;

5 Figure 26 is a side view of a dual substrate sensor device of the invention showing how the shape of the sheathing may be configured to minimize turbulence and reactionary fluid forces in the heart;

Figure 27 is a side view of another embodiment of the invention illustrating how the shape of the sheathing may be configured to minimize turbulence and reactionary fluid forces in the heart; and

10 Figure 28 is a block diagram of the major electronic components of an external reader constructed according to the principles of the invention for telemetrically receiving data from an implanted sensor device.

DETAILED DESCRIPTION OF THE INVENTION

15 The embodiments of the invention and the various features and advantageous details thereof are explained more fully with reference to the non-limiting embodiments and examples that are described and/or illustrated in the accompanying drawings and detailed in the following description. It should be noted that the features illustrated in the drawings are not necessarily drawn to scale, and features of one embodiment may be
20 employed with other embodiments as the skilled artisan would recognize, even if not explicitly stated herein. Descriptions of well-known components and processing techniques may be omitted so as to not unnecessarily obscure the embodiments of the invention. The examples used herein are intended merely to facilitate an understanding of ways in which the invention may be practiced and to further enable those of skill in the art
25 to practice the embodiments of the invention. Accordingly, the examples and embodiments herein should not be construed as limiting the scope of the invention, which is defined solely by the appended claims and applicable law. Moreover, it is noted that like reference numerals reference similar parts throughout the several views of the drawings.

30 Figure 1 schematically illustrates an embodiment of an implantable telemetric measuring device and reader constructed according to principles of the invention providing for continuous or regular intra-cardiac pressure monitoring. A coil or antenna 14 connected with an external reader 12 generates a radio frequency (RF) field in a manner known in the art. The coil 14 and external reader 12 may be fixed to individual belts that
35 wrap around the patient and connect to each other via a standard cable. The RF field induces a current in a coil 18 connected to a substantially rigid sensor device 20, such as

described herein, implanted within the heart 16 of the patient 10, such as the septum or the wall of the left atrium, to sense pressure in the left atrium. The sensor device 20 may consist of an application specific integrated circuit (ASIC) such as described herein, having power conditioning circuitry that detects when adequate power is being delivered and switches on sensing, analog-to-digital, and data processing circuits. The data processing circuitry sends the sensor data to the ASIC transmitter, which uses the coil 18 as an antenna. The coil 18 telemetrically transmits, via signal 22, the data to the antenna 14 of the external reader 12. The external reader 12 may provide secure reception and storage of pressure and temperature values, compare the pressure reading of the implanted device 20 to ambient pressure via an internal sensor in the reader, and deliver the intracardiac data to other devices, such as computers, personal digital assistants (PDAs), cell phones, etc., via standard protocols.

In this embodiment, the external reader 12 may obtain data from the sensor device 20 at continuous or regular intervals. By way of example, the external reader 12 may continuously generate an RF signal to activate the sensor device 20 to obtain pressure and/or temperature readings (in order to describe even the waveform of the blood pressure, if desired by the doctor, the sensor device should take up to 100 or more measurements per second). Alternatively, the external reader 12 may generate an RF signal at regular intervals (e.g., every half hour, once every four hours, once a day) to activate the implanted rigid sensor device 20 to obtain pressure and/or temperature readings.

Figure 2 schematically illustrates another embodiment of an implantable telemetric measuring device and reader, which may operate similarly to the Figure 1 embodiment but provides for on demand intra-cardiac pressure monitoring according to principles of the invention. In this embodiment, a coil 28 in a hand-held reader 26 generates an RF field that induces a current in the coil 18 of the substantially rigid sensor device 20 implanted within the heart 16 of the patient 10, as in the Figure 1 embodiment. As described above, sensor device 20 may include an ASIC that operates similarly to the Figure 1 embodiment. Thus, power conditioning circuitry in the sensor device 20 detects when adequate power is being delivered, and turns on the sensing, analog-to-digital, and data processing circuits. The data processing circuitry sends the sensor data to the ASIC transmitter, which uses the coil 18 as an antenna. The coil 18 transmits, via signal 24, the data to the antenna 28 of the hand-held reader 26. The hand-held reader 26 may be extendable to expose the antenna 28 and provides reception and storage of pressure and temperature values, and compares the implant's pressure reading to ambient pressure via an internal sensor in the readout device. The hand-held device 26 may deliver the

intracardiac data to other devices, such as computers, PDAs, cell phones, etc., via standard protocols.

In this embodiment, the reader unit 26 may obtain data from the implanted sensor device 20 on demand. By way of example, a user may activate and cause the reader unit
5 20 to generate an RF signal by extending the top portion containing the antenna from the bottom portion of the reader unit housing to activate the implanted rigid sensor device 20 to obtain pressure and/or temperature readings.

Figure 3 illustrates a cross-sectional view of the heart area of a patient where the implanted device may be employed, including the left and right atrium and the crossing of
10 veins at the posterior septum. The heart 30 has a right atrium 32 and a left atrium 34, which are divided by the septum 36. As described in more detail herein, it may be advantageous to locate and/or anchor the implantable sensor device 20 at the septum 36 separating the right atrium 32 and the left atrium 34, such that a portion of the sensor 20 extends into the chamber to be sensed, e.g., the left atrium 34. The implantable device
15 may work as a short-term implant as well as a long-term implant, and may be implanted at the "Whaterstone's groove" near the access of the pulmonary vein or other locations chosen by a doctor. The implantable sensor device 20 also may be designed to facilitate ready removal of the device if medically necessary. An embodiment of such a removable device is illustrated in Figure 23.

Figure 4 illustrates a substantially rigid sensor ASIC constructed according to
20 principles of the invention for sensing intra-cardiac pressure and temperature in any of the embodiments of the invention. The ASIC 400 contains pressure sensing elements 402, such as eight passive sensors 404 and eight active sensors 406, temperature sensor 408, an analog-to-digital (A/D) converter 410, data transmission circuitry 412, power
25 conditioning circuitry including components such as smoothing and resonance capacitors (not shown), a digital state control 414 including a code redundancy check for secure data transmission and memory 416, such as Electrically Erasable Read-Only Memory (EEPROM) cells, for unit identification, which are components known in the art. An example of the suitable ASIC structure is described in U.S. Patent Nos. 5,321,989 and
30 5,431,057, the contents of which are expressly incorporated by reference in their entirety.

According to the principles of the invention, the ASIC 400 should be an extremely small and lightweight chip to avoid placing undue stress on the heart and/or producing turbulent flow in the heart chamber(s). For example, an ASIC particularly adapted for use
35 in the embodiments described herein as being implanted during open chest surgery should weigh less than fractions of a gram, have a surface area of less than or equal to about 10 mm² per side, and a thickness of about ¼ mm to about 1 mm. In one

advantageous embodiment, the ASIC may be about 2mm wide by 5mm long by about 250 to 800 microns thick. Other dimensions may also be used depending upon the particular application or location in the cardiovascular where the sensing will occur and depending upon the delivery method. In general, the dimensions of the ASIC 400 may
5 range from about 3 mm to about 8 mm long, about 0.6 mm to about 2.5 mm wide, and about 0.2 mm to about 1.3 mm high. Other dimensions, such as an ASIC that is substantially square, may also be used.

In the embodiment of the invention shown in Figure 4, the ASIC 400 includes sixteen capacitive pressure sensors cells 402, eight of which are active pressure sensors
10 406 and provide pressure data, and eight of which are passive pressure sensors 404 and act as an internal reference. The pressure sensor cells 402 may include minute, flexible membranes that are housed within the substantially rigid ASIC structure as shown schematically in Figure 5. Specifically, the active pressure sensors 406 have flexible
15 membranes 424 and passive pressure sensors 404 have flexible membranes 426. The membranes 424 of the active pressure sensors 406 are distortable based on the level of cardiac blood pressure. The distortion may be mainly in a direction generally perpendicular to the planar top surface of the ASIC 400. The distortion may be determined based on capacitive measurements or by use of distension measuring tapes. By way of one specific exemplary embodiment, the sixteen capacitive pressure sensing
20 elements 402 of the ASIC 400 may each be about 96 microns in diameter.

As the pressure changes in the heart, the capacitance measured in the pressure sensors 402 changes. The pressure sensors 402 generate signals based on the change in capacitance, and thus indicative of the pressure in the heart. As will be described
25 below, the signals preferably are processed by components located in or on the ASIC 400 and transmitted to an external reader.

Thus, the blood pressure measuring process may be a capacitive pressure measurement process via measuring membranes 424, 426 that are integrated into the ASIC 400, such as the planar top surface of the chip as shown in Figure 5. The ASIC 400 may have a substantially inflexible, substrate made of silicon that cannot be folded or
30 rolled up. The thin, but mechanically inflexible substrate creates a mechanically stable device providing a substantially rigid structure to house the measuring membranes 424, 426 as shown in Figure 5. Changes in the geometry of the ASIC 400, such as twisting due to blood turbulences, may be avoided due to this substantially rigid, chip-based configuration, even when the ASIC 400 is exposed to turbulent, blood flow. Thus, the
35 implanted ASIC 400 provides a durable device capable of withstanding the internal

environment of the heart and other locations in the cardiovascular system without producing dangerous stresses within the heart.

Numerous small membranes 424, 426 having relatively small dimensions (e.g., a diameter of less than 0.2 mm) may be used as capacitive pressure sensors. Such small dimensions may result in membranes 424 that are less vulnerable to mechanical forces, such as the force of blood flow within the heart, and therefore more reliable.

The ASIC 400 contains mechanical and electrical elements that are subject to wear and need drift compensation to obtain measurements of suitable quality and reliability for their intended cardiovascular uses. Drift in a sensor may occur as time passes and physical properties of the structure change. Over time and usage, changes in electronics in a chip may effect the measurements. Further, when a pressure sensor uses a membrane, the membrane may sag in the middle as it ages. The capacitance at the pressure sensor membrane varies based on the change in position of the pressure sensor membrane. These changes, unrelated to the change in blood pressure, may alter the true value of the measurements being sensed. Drift compensation is particularly important in an intra-cardiac long-term pressure sensor.

The drift compensation scheme employed in ASIC 400 should reduce or eliminate the effects of the change in the physical properties of the ASIC 400. According to the principles of the invention, the drift of the pressure values obtained from the sensor structure 400 may be minimized to a value of about 5.0 mmHg/year to about 2.5 mmHg/year or even smaller than 1mmHg/year.

In accordance with drift compensation principles of the invention, a plurality of active sensors 406 and a plurality of passive sensors 404 are provided, such as eight of each. According to an embodiment of the invention, the structure of the active sensors 406 and the structure of the passive sensors 404 are identical. However, as illustrated in Figure 5, the membranes 424 of the active sensors 406 are open to the sensing environment (e.g., a heart chamber) for sensing pressure, while the membranes 426 of the passive sensors 404 are isolated from the environment, e.g., by placing a glass layer 428 or other suitable material over the surface of the membrane 426 so that pressure in heart will not affect the passive sensors 404. Both the active sensors 406 and passive sensors 404 are affected substantially the same by age, usage and sagging and any other effects of the environment. Using the passive sensors 404, the ASIC 400 may determine how much of the change in position of the pressure sensor membrane 426 is effected by the age and sagging. The change in capacitance based on the change in position of the passive pressure sensor membrane 426 is determined. This amount is then used to offset the change capacitance measured in the active pressure sensor membrane 424.

This system allows the change in capacitance due the pressure within the heart to be more accurately determined. Compensating for drift may allow a doctor or patient to better determine short term (e.g., days, weeks) trends in pressure within the patient, such as the heart.

5 The implantable sensor device, which may include the ASIC 400, a connector and an antenna, may be completely encapsulated within a seamless biocompatible sheathing (not shown in Figs. 5-6). The material areas around the measuring membranes 424 maintain their flexibility after encapsulation to allow transmission of the pressure to the measuring membranes 424. The biocompatible sheathing will be described in greater
10 detail below.

 Figure 6 is a cross-sectional view of the ASIC 402 of the invention with a gel or fluid between a sheathing and the active pressure sensors 406. As described above, a glass substrate 428 or other suitable material isolates the passive pressure sensors 404. A liquid or gelatinous pressure transmitting medium 432 is used between sheathing 430
15 and the active pressure sensors 406. As will be described below, this liquid or gelatinous medium 432 may improve the measurement or reception of blood pressure values within the chamber to be sensed, e.g., within the left atrium. Even though fibrous tissue or plaque may grow in the area of the implant over time (e.g., months or years after the implantation), encapsulating the pressure sensors within a separate gel-filled membrane
20 may allow reliable measurement values to still be obtained.

 For example, endothelialization may result in endothelia being deposited on the surface of the sensor structure. If endothelia and/or plaque are deposited on the surface of one of the active pressure sensors, or on the biocompatible sheathing at the surface of one of the active pressure sensors, pressure measurement readings may be adversely
25 affected. One way to reduce such an effect is to coat the sheathing and/or sensors with a drug, e.g., heparin, to reduce or eliminate endothelia. However, such treatments may not always be effective.

 Thus, as illustrated in Figure 6, the surface of the active pressure sensors 406 are coated with a gel or fluid 432 and encapsulated in the membrane 430. In this manner,
30 endothelia growth or plaque on the membrane 430 directly over the surface of one of the active pressure sensors 406 will have a reduced or negligible effect on the pressure sensor measurement, as the pressure is transmitted via the endothelia growth and the membrane 430 through the gel/fluid 432 to the active pressure sensors 406. Further, plaque growth and/or endothelialization on the entire surface would still allow pressure
35 sensing measurements to be obtained, as the pressure exerted on the endothelia is transmitted via the gel/fluid 432 to the active pressure sensors 406. In particular, the

gel/fluid filled membrane 430 may function to integrate the change in pressure over a larger area than the individual active pressure sensors 406 themselves. This minimizes the effects of endothelization and/or plaque adherence to the sheathing 430. Although sheathing 430 is shown as only covering the gel/fluid 432, it is understood that the sheathing 430 or other sheathings could cover part or all of sensor device 400, as
5 described below.

As described above, the ASIC 400 includes an A/D converter 410. As is known in the art, the pressure sensors 402 provide analog signals indicative of the pressure in the heart. The A/D converter 410 converts the signals from the pressure sensors 402 to
10 digital signals.

Thus, the transmission and digitizing of measurement values into appropriate signals in the invention is preferably carried out within or very closely adjacent to the heart chamber or chambers to be sensed, such as the left and/or right atrium and/or the left or right ventricle, and most preferably are processed inside the ASIC 400. Using a fully
15 digital system may result in greater accuracy of the readout. In an analog system, where the amplitude of the signal is proportional to the pressure reading provided by the sensors, the value of pressure recorded by an external reader depends upon the distance between body and reader. As a result, either the distance from the body to reader must be very tightly controlled, or the accuracy of the system will suffer. According to the
20 invention, the distance from body to reader has little or no effect on the pressure value measurement received due to the use of a digital signal and to processing the signals at or very near the sensor. This may make the system more robust and accurate than analog systems.

In addition, the fully digitized data can be handled for more easily by data
25 transmission systems, making the external readers compatible with computer, Internet and telemedicine interfaces. For example, highly accurate pressure sensors and a 9-bit analog-to-digital converter may impart high resolution to the sensing systems, where an accuracy of about +/- 2 mm Hg or less may be achieved.

Further, digitization at the ASIC 400, as opposed to analog signal transmission via
30 an antenna before digitization, may avoid interference issues from other, unrelated RF sources. In prior devices, analog signals are sent from the sensor to the antenna structure via a wire. By processing and converting the analog signals to digital signals prior to transmission over the wire to the antenna, the system may avoid analog interference that may be induced in the wire by external RF signals and noise, such as
35 radio broadcasts, electronics, and the like.

The ASIC 400 measures pressure at the pressure sensing elements 402 and transfers the absolute pressure signals to an external reader. A pressure value is calculated from the difference of absolute pressure value, measured with the ASIC 400, and the atmospheric pressure surrounding the patient as is well-known in the art. This atmospheric pressure may be measured within the external reader, which is normally in the surrounding environment of the patient.

The operation of the ASIC 400 is based on the interaction between a connected antenna, such as shown in Figure 23, and an external reader according to well-known principles of transponder technology. Therefore, no internal power source is required. The ASIC 400 and the external reader may be tuned so that continuous measurements, e.g. up to 120 single measurements per second, may be processed and transmitted. As described above in Figure 1, the total system may be programmed so that measurements are taken and stored in given intervals or at defined time periods. Retrieval, monitoring, and recording of data may be possible at any time.

According to an embodiment of the invention, the ASIC 400 preferably consists of a single integrated chip. All relevant functions and components for the measuring process, digitizing, identification number transmission, power supply, and telemetric data transmission are integrated into the single integrated chip. As described above, the ASIC 400 may contain a specific identification number, as well as a chip specific calibration file and further circuit and storage components. Alternatively, the circuit components may also be placed on two or more chips, e.g. if sensing in separate locations is desired.

The ASIC 400 may be formed from a single complementary metal oxide semiconductor ("CMOS") chip to produce a smaller implantable device than with other methods, and help minimize power use and maximize measurement accuracy reliability. Since the consumption of power produces heat, minimization of power may be desirable in implantation applications. In a one-chip solution, the ASIC 400 may be highly resistant to mechanical or electrical interference from the outside, as there is no interaction between multiple chips.

The power consumption of the chip may be low, so that if an increase of temperature occurs in the course of inductive/transponder related power insertion, difficulty in measuring or data transmission may be reduced or avoided. The optimized circuit design may result in a very low power consumption, such as only about 210 microwatts at about 3 volts DC. The sampling rate may be about 20 to about 120 Hz. The high integration factor of the logic circuit combined with the high speed of data transmission may allow the use of a very secure data transmission protocol, thereby addressing concerns of the regulatory authorities.

An integrated temperature sensor 408 may be provided in the ASIC 400 to allow for temperature sensing as shown in Figure 4. The temperature sensor 408 may use the circuit in the ASIC 400 and base the temperature measurement on current characteristics within the circuit, thereby determining the temperature in the heart based on the temperature based current characteristics within the ASIC 400. Each ASIC 400 may be individually calibrated to determine its current characteristics (magnitude, frequency, etc.) at a given temperature (e.g., body temperature). As the temperature changes, the current characteristics within the ASIC 400 change. Using the information on the current characteristics and the specific calibration determination for the ASIC 400, the temperature at a particular time can be determined based on current characteristics at that time. The raw pressure data must be corrected for temperature and other external and/or internal influences, and calibration information, such as a calibration curve of the embedded chip, may be established for each ASIC 400 or system that implements an ASIC 400. Each ASIC may have a unique identification number to facilitate calibration and use of data as discussed below.

The ASIC 400 includes a data memory 416, such as the EEPROM cells, in which the unique identification number may be stored. This identification number is transmitted telemetrically together with the measurement values. The identification number may be used to determine the appropriate calibration information for an ASIC 400. Also, a single external reader may then be used to interrogate multiple implanted ASIC's, as described below.

The unique identification number may be transmitted along with the sensor data to the external reader to allow the external reader to use the correct calibration information to calculate pressure and/or temperature. An external reader (as described in greater detail below), may have a memory to store calibration information for a number of ASICs 400 or systems that implement ASICs 400. The appropriate calibration information is associated the appropriate ASIC 400 or system via the identification number. With the identification number, or other identification indicia, the external reader accesses the calibration information associated with the particular ASIC 400 or system that includes the particular ASIC 400. The data received by the external reader is processed using the appropriate calibration information to achieve more accurate results.

Each ASIC 400 and/or system also may be zeroed prior to implantation. When inside the patient, the system compares the measured pressure to the pressure in a vacuum. Outside the patient, the external reader compares the ambient pressure to the pressure in a vacuum. Pressure inside the heart is calculated by comparing the difference between the pressure measured inside the heart and the pressure measured outside the

patient. Zeroing the ASIC 400 or the system may involve using the ASIC 400 system to measure the pressure outside the patient and comparing this measurement to the pressure obtained by another external device. The difference between these two readings may be stored with the calibration information associated with the ASIC 400 or system and used to adjust future pressure measurements by the ASIC 400 or system once it has been implanted to account for the difference.

Using one or more transponder coils, an external reader may be used for the power supply of the ASIC. This unit also may be used for telemetric data acquisition. The range for telemetric power supply and data transmission may be from about 3 cm to about 35 cm or other ranges as can be readily determined by a skilled artisan. This range also may depend on the distance between the external reader and the implanted antenna and the size of the antennas

Measurement data are processed and preferably are digitized on the ASIC 400 for transmission from the sensor structure to the interior transponder coil. The transmission of the measurement data from the ASIC 400 to the interior transponder coil may be realized via one or more electric conductors, preferably designed as flexible thin wires, embedded in silicone on other nonconducting material. Measurement data are transmitted telemetrically from the interior transponder coil to the external reader. The external reader capacities may be designed for an exterior supply of all power resources which are required for the continuous operation of ASIC 400, including measurements and data transmission.

The ASIC 400 also includes a bi-directional power circuitry 424 for working with the reader to evaluate the strength of the signals sent between the reader and the ASIC 400. The components in the bi-directional power circuitry 424 interact with a reader to ensure that appropriate signal strength and data transmission is achieved. The interaction between the bi-directional power evaluation module 424 and the reader is described in greater detail below with respect to Figure 28.

Figures 7 and 8 schematically illustrate an embodiment of an implantable sensor device 700 of the invention including a substantially rigid sensor chip connected at two ends to a substantially rigid substrate 708 having a cut out. A sensor chip 702, such as ASIC 400, includes pressure sensing membranes 704 and four spaced chip bond pads 706. A substantially rigid substrate 708 having an aperture 710 and bond tracks 712 connected to bond pads 706 are also provided. The substrate 708 is configured in a spaced apart relationship to the sensor chip 702. More particularly, the aperture 710 of the substrate 708 is located substantially opposite of the capacitive pressure membranes 704 of the sensor chip 702 so pressure from the blood surrounding the device may be

transmitted readily to the pressure membranes 704. A pressure transferring material (not shown) may be located at the aperture 710 to ensure that pressure from the blood is transferred to the pressure membranes 704.

The sensor chip 702 and the substrate 708 may be configured in a fixed
5 relationship, so that the distance, or offset, between the sensor chip 702 and the substrate 708 does not change. The chip bond pads 706 may be connected to the substrate bond pads 712 to fix the distance between the sensor chip 702 and the substrate 708. As shown in the embodiment of Figures 7 and 8, the sensor chip 702 and the substrate 708 both have four bond pads. However, it is understood that other amounts of bond pads
10 may also be used.

At least one of the substrate bond pads 712 may be elongated in the form of a track to facilitate connection to an electrical wire 714 that connects to an antenna (not shown). Electrical wire 714 is connected to the substrate bond pad 712 by any
15 conventional method, such as by using heat and pressure. Connecting the electrical wire 714 to a substrate bond pad 712, as opposed to being directly connected to chip 702, may reduce or eliminate damage to or malfunction by the sensor chip due to the connection process. The electrical wire 714 is electrically connected to the sensor chip 702 via the electrical connection between the substrate bond pad 712 and the chip bond pad 706.

Figures 9 and 10 schematically illustrate another embodiment of an implantable
20 sensor device including a substantially rigid sensor chip connected at one end to a substantially rigid substrate having a cut out. The device 900 of Figures 9 and 10 has similar components and operation to the device 700 illustrated in Figures 7 and 8. However, device 900 has chip bond pads 906 located in generally close proximity to each other at one end of the sensor chip 902. In addition, the substrate bond pads 912 are
25 generally located in close proximity to each other on the substrate 908. When the chip bond pads 906 and the substrate bond pads 912 are connected, the sensor chip 902 and the substrate 908 are fixed at one end, with the other free end being supported in a cantilevered manner. This arrangement of chip bond pads 906 and substrate bond pads 912 may reduce stress on the sensor chip 902, as changes in the size of the substantially
30 rigid substrate 908, such as due to thermal expansion, may have less of an effect on the sensor chip 902 due to the location of the chip bond pads 906 on the sensor chip 902.

The device 900 may further include a flexible filler material 916 located between the sensor chip 902 and the substrate 908. As shown, the filler 916 may be located
35 throughout the area between the sensor chip 902 and the substrate 908 except at the aperture 910 that is opposite the capacitive pressure membranes 904. Filler 916 may be any flexible material that can provide support to reduce or eliminate movement in the

offset direction between the sensor chip 902 and the substrate 908. The filler 916 may be the same material used to surround the implanted device 900, such as a biocompatible material like silicone or other similar material.

Figure 11 is a perspective illustration of an implantable sensor device such as the Fig. 7 and 8 or Fig. 9 and 10 embodiments showing the electrical wire and core filament connection to the ASIC and antenna. The device 1100 includes a substantially rigid sensor chip 1102 having pressure membranes 1104, and a substantially rigid substrate 1108 with an aperture 1110 exposing the pressure membranes 1104. A pressure transmitting material 1112, such as a liquid or gelatinous material, is located within the aperture 1110 to transmit pressure from the blood to the pressure membranes 1104. The entire device 1100 is enclosed by a biocompatible sheathing 1106, such as silicone. In addition, the sheathing 1106 can also be used as the pressure transmitting material 1112 within the aperture 1110.

Substrate 1108 may further include connector holes 1120 for facilitating attachment of an antenna connector 1114 to the substrate 1108 and the sensor chip 1102. The connector 1114 includes electrical wires 1116 and a filament core 1118, such as nylon. Electrical wires 1116, which may be formed of gold cable, or other appropriate material, provide an electrical connection between the sensor chip 1102 and an antenna (not shown). Electrical power from the antenna may be conducted via the electrical wires 1116 to the sensor chip 1102 for powering the sensor chip 1102 to obtain measurements. Signals, such as pressure measurements and identification indicia, may be transmitted over the electrical wires 1116 from the sensor chip 1102 to the antenna for transmission to a reader. The filament core 1118 provides strength to the connector 1114 to reduce or eliminate strain on the connection between the substrate bond pad (not shown) and the electrical wires 1116. The filament core may be made of nylon or other similar, synthetic flexible material that does not conduct electricity and has a low coefficient of thermal expansion. This connection will now be described in greater detail below with reference to the examples of Figures 12-14.

Figures 12 and 13 illustrate an implantable sensor device 1200 with a cut out located at an edge of the substantially rigid substrate, including a cable and core filament connection, while Figure 14 schematically illustrates the cable and core filament connection to the substrate. The implantable device 1200 includes a substantially rigid sensor chip 1202 having pressure membranes 1204. In this embodiment, the capacitive pressure membranes 1204 are located near the edge of one side of the sensor chip 1202. The device 1200 further includes a substantially rigid substrate 1208 having connector holes 1220 and a cut out 1210 opposite of the pressure membranes 1204. A pressure

transmitting material 1212 is located within the cut out 1210 to transmit pressure from the blood to the pressure membranes 1204. The device 1200 is surrounded by a biocompatible sheathing 1206, such as silicone. According to a preferred embodiment of the invention, the pressure transmitting material 1212 may be the same as the sheathing material 1206.

The device 1200 further includes a connector 1214 which includes electrical wires 1216 and a filament core 1218. The electrical wires 1216, which may be formed of gold, or any other suitable similar material, connect to substrate bond pads 1222, and the substrate bond pads 1222 are connected to chip bond pads 1224. This results in an electrical connection between the electrical wires 1216 and the sensor chip 1202. The filament core 1218 may be attached directly to the substrate 1208, such as by an adhesive. As shown in Figure 14, the filament core 1218 is threaded through the connector hole 1220 for attachment to the substrate 1208 such that the electrical wires 1216 have extra slack when the filament core 1218 is pulled straight. This configuration may reduce or eliminate the strain on the connection between the electrical wires 1216 and the substrate bond pad 1222 when there is movement of either the connector 1214 or the substrate 1208. Any other method providing for strain relief known in the art of electrical wires 1216 may also be used.

Figures 15 and 16 schematically illustrate an implantable sensor device with a cut out located at an edge of the substrate and a protective barrier wall located at one end of the substrate. The device 1500 has a substantially rigid sensor chip 1502 having capacitive pressure membranes 1504 (shown in Fig. 16). The device 1500 further includes a substantially rigid substrate 1508 having a cut out 1510 located substantially opposite the pressure membranes 1504. A chip bond pad 1518 on the sensor chip 1502 is connected to a substrate bond pad 1520 of the substrate 1508 in a conventional manner. The device 1500 is encapsulated in a biocompatible sheathing 1506.

The substrate 1508 includes a barrier wall 1514 that may be substantially perpendicular to the plane of the substrate 1508. The height of the barrier wall 1514 may be such that the top of the barrier wall 1514 is at or above the top of the sensor chip 1502 when it is attached to the substrate 1508. The barrier wall 1514 may provide additional protection to the chip sensor 1502, such as preventing the sharp ends of the chip 1502 from wearing or puncturing the sheathing 1506. In addition, a front portion 1512 of the substrate 1508 shaped like an arrow is located beyond the barrier wall 1514 and is tapered to reduce or eliminate the effects of blood turbulence on the chip sensor 1502, as well as aid in the implantation of the device 1500 within the heart. This may occur when the tapered portion 1512, and thus the device 1500, is inserted into the heart. The edges

of the barrier wall may be slightly rounded (not shown in the drawings) to avoid any wearing or puncturing of the sheathing. Although not shown, it is understood that a pressure transmitting material and/or a filler material may be used with the device 1500.

Figure 17 schematically illustrates a cross sectional view of a further embodiment of a barrier wall formed as an end cap at one end of the sensor device. The device 1700 has a sensor chip 1702 having capacitive pressure membranes 1704. The device 1700 further includes a substrate 1708 having a cut out 1710 located substantially opposite the pressure membranes 1704. A chip bond pad 1718 on the sensor chip 1702 is connected to a substrate bond pad 1720 of the substrate 1708 in a conventional manner. The device 1700 may also be encapsulated in a biocompatible sheathing (not shown in Figure 17).

The substrate 1708 may include a barrier wall 1714 that is substantially perpendicular to the plane of the substrate 1708, as in the prior embodiment. The height of the barrier wall 1714 may be such that the top of the barrier wall 1714 is at or above the top of the sensor chip 1702 when it is attached to the substrate 1708. In addition, the barrier wall includes a top cover 1716 extending inwardly from the top of the barrier wall 1714 substantially parallel to the substrate 1708 over the sensor chip 1702 to provide protection to the top of the sensor chip 1702. Although shown in Figure 17 as extending over only a small area of the sensor chip 1702, it is understood that the barrier top cover 1716 could extend further, including along the entire length of the sensor chip or beyond. The barrier wall 1714 and the barrier top cover 1716 may provide additional protection to the chip sensor 1702 and the sheathing as discussed above. More specifically, the barrier top cover 1716 may inhibit damage to the sheathing 1706 that could occur by rubbing of sharp edges of the chip sensor 1702 against the sheathing material 1706. In addition, a front portion 1712 of the substrate 1708 is located beyond the barrier wall 1714 and may be tapered to reduce turbulence, as well as aid in the implantation of the device 1700 within the heart, also as discussed above.

Figure 18 schematically illustrates an integrally formed ASIC and holder of the invention in a greatly enlarged scale implanted in a wall of the heart after surgery. The implantable sensor device of this embodiment may include a substantially rigid substrate 1802 including an ASIC 1804, which is located at one end of the substrate 1802. The substrate may be elongated such that a holder portion 1810 is integrally formed therewith and anchored within a wall of the heart such that the ASIC is at least partially exposed within the chamber of the heart to be sensed. At a minimum, the active pressure sensors must be exposed. The other end of the substrate 1802 is the holder portion that is affixed within a heart wall 36, such that part of the holder portion 1810 of the substrate 1802 is located on the other side of the heart wall 36. A wire 1808 may also be affixed to the

substrate 1802 and connect the ASIC 1804 to an antenna (not shown). The holder portion 1810 of the substrate 1802 may be configured to form part of an anchor structure. For example, the outer portion may include a bend, elbow, or other configuration to facilitate anchoring with or without separate affixing means known in the art, such as sutures or the tobacco pouch suture 1806 schematically shown in Figure 18 surrounding the exposed end of the holder portion 1810.

Figure 19 schematically illustrates on a greatly enlarged scale another integral ASIC and holder of the invention having a "T" shape anchor implanted in a wall of the heart. In this embodiment, the substantially rigid substrate 1902 includes an ASIC 1908 and an integral holder 1910 having an anchor 1906 such that the substrate 1902 and the anchor portion 1906 are configured in a generally "T" shape, with the free end extending through the heart wall. An antenna 1912 may be attached directly to the anchor 1906 and/or substrate 1902. The antenna 1912 may be in the form of a coil wrapped around the T-shaped end of the holder 1910 and connected to the ASIC 1904 by a wire 1908 located on the substrate 1902. This may reduce the distance of the wire 1908 required or essentially eliminate it.

Figure 20 schematically illustrates an ASIC and a holder of the invention in the form of an elbow connector for holding the ASIC and guiding a slack portion of the connecting wire. As illustrated in Figure 20, an elbow or bend, separately connected to or integrally formed with the substrate 2002, may be used to connect and/or guide the wire 2006 to an ASIC 2004 held at the other end of the elbow connector. The wire 2006 may be connected in such a way as to minimize the movement of the wire 2006 at the connection point 2008. As shown, the ASIC 2004 is attached to the elbow 2002. The wire 2006 is attached to both the ASIC 2004 (at 2008) and the elbow 2002 (at 2010). The connection of the wire to the elbow 2002 at 2010 may absorb the stress of wire movement, thereby ensuring the fail-safe connection between the wire 2006 and the substantially rigid sensor chip 2004 through the numerous cycles anticipated during the life of a patient. While various embodiments of the invention show a holder with an anchor, separate anchor structure may not be necessary, as the heart wall naturally closes around the sensor device.

The wire 2006 connects the ASIC 2004 to the antenna (not shown) and may be made of flexible material that allows a signal to be transmitted between the sensor structure and the antenna structure. The wire may be made of gold, platinum, iridium, stainless steel, spring steel, or similar material. The wire is totally embedded (surrounded) by a flexible mantle.

As illustrated in Figure 20, it may be desirable for wire connection to have some predetermined amount of slack in the wire to account for the movement of the heart without placing undue stress on the components. Thus, the slack may take the form of a bend or loop in the wire 2006 at or near the connection 2010 of the wire 2006 to the bend 5 2002, as shown. This slack will avoid excessive bending and/or stress on the wire 2006. Slack may also reduce or eliminate additional strain on the heart, as there is little or no increased effort necessary for normal heart pumping due to the sensor implant. Other configurations to provide slack, reduce bending or stress in the wire 1006 and reduce strain on the heart may also be used.

10 Figure 21 is a three-dimensional representation of a holder of the invention that mounts the ASIC in the wall of the heart and includes suture wings that limit movement of the ASIC, e.g., during implantation by a doctor, and serve as suture mounts. The implantable sensor device 2100 includes a ASIC 2102 having capacitive pressure membranes (not shown) formed on a substantially rigid substrate 2108 having a cut out 15 2110 substantially opposite the pressure membranes as shown and described above. A connector 2114 having electrical wires 2116 and a filament core 2118 is also provided. The device 2100 also includes a holder 2112 (shown in dashed lines) for supporting the ASIC 2102 and the substrate 2108 and mounting it to the wall of a heart. A receiving portion 2120 of the holder surrounds and fixedly receives a portion of the substrate 2108 20 such that cut out 2110 is exposed. When the device 2100 is inserted into the heart wall, transversely extending flange 2122 forms a pair of suture wings that act as stops to ensure that the device 2100 is not inserted too far. In addition, the suture wings 2122 may be used in conjunction with sutures for anchoring the device 2100 to the heart. While two wings are shown in Figure 21, the flange 2122 could be formed with three or more wings if 25 desired. The holder 2112 may also include a connector attachment portion 2124 to provide a conduit for connecting the wires 2116 and core 2118 to the sensor chip 2102 via the substrate 2108.

Figure 22 is a three-dimensional representation of another embodiment of a holder of the invention which is similar to the Figure 21 embodiment but includes an end cap 30 2224 to provide further protection to the sensor chip 2202 and substrate 2208, such as when the device 2200 is inserted through a heart wall.

Figure 23 is a three-dimensional representation of a holder of the invention illustrating how it connects the ASIC via a flexible cable to an antenna. The implantable device 2300 generally includes a holder 2306 receiving an ASIC 2302 formed on a 35 substantially rigid substrate 2304. A flexible connector 2308 electrically connects the ASIC 2302 and an antenna 2310. The entire device 2300, including the holder 2306,

connector 2308, and antenna 2310, is encapsulated in a biocompatible sheathing, such as a seamless sheathing of silicone.

The antenna 2310 serves both as power transducer and antenna, and may be fabricated of any type of conductive metal. The antenna 2310 may be made of pure gold, or any other suitable material, to provide both biocompatibility and the necessary degree of electrical conductivity. According to a preferred embodiment of the invention, the antenna 2310 and the connector 2308 may be made of the same material, and the connector 2308 may be part of the antenna 2310, e.g., the connector 2308 and the antenna 2310 are integrally formed. The antenna 2310 may be extremely thin (for example, about 25 microns) and light weight. All components of the implantable device 2300, including the antenna 2310, the connector 2308, and the holder 2306, may be very small and light weight to avoid strain and irritation of the heart when implanted. Thus, by of example, the holder 2306 may be made of a light weight plastic, and coils in antenna 2304 and wires in connector may be made of a relatively thin and lightweight wire material, such as thin gold or other suitable materials.

The number and size of the coils of the antenna 2310 may be dimensioned in such a way that an appropriate telemetric range between the internal and external coils is achieved. For the embodiment shown in Figure 23 in which the antenna is fixed subcutaneously, the minimum range for the transmission of measurement data from the internal coil to the extra corporal emitter/receiver unit is about 2 cm to about 25 cm. If the antenna is fixed at or near the heart, the range may be closer to the high end, i.e. about 25 cm. However, this required range may change based on the position of the antenna.

As described above, all energy which is required for the acquisition of measurement data may be provided telemetrically by the antenna 2310, where the coil may be designed as a passive coil. Examples of suitable coils are illustrated in German patents DE 199 45 879 A1 or DE 101 56 469 A1. By way of example, the antenna 2310 may be formed from a cable that is wound into a plurality of coils. The cable may also connect the antenna 2310 to the sensor chip.

Figure 24 schematically illustrates an implantable sensor device of the invention encased in a biocompatible sheathing. A sensor device 2400 includes an ASIC 2404 positioned on a substantially rigid substrate 2402 and encapsulated in a biocompatible sheathing 2406. The sensor system, i.e., the ASIC 2404, substrate 2402, cable (not shown) and antenna (not shown) may be encapsulated in a biocompatible sheathing such as, silicone, polyurethane or other suitable material. The encapsulation of the system preferably is seamless, i.e., has no break or seam. This reduces or eliminates the risk of contamination or damage to the sensor system structure by fluids within the body. By way

of example, the thickness of the encapsulation may be in the range of about 0.01 mm to about 0.8 mm. A seamless sheathing may be obtained by seamless molding or by dipping the entire sensor device 2400 (sensor ASIC, cable and antenna) into the biocompatible material.

5 The implanted device may be positioned in heart to minimize turbulence of the blood flow within the heart chamber and reactionary forces. As illustrated in Figure 25, the sensor device 2400 may be orientated such that its shortest side, such as side 2412, may be positioned to be in the most upstream position in the blood flow path 2416. This presents the minimum area in the blood flow and reduces and/or minimizes currents and
10 reactionary forces caused by the implanted device 2400. This positioning may be done regardless of location of the pressure sensors 2408 on the chip. As illustrated, the longer sides 2410 of the sensor device 2400 containing the top surfaces of the capacitive pressure membranes 2408 may be parallel to the blood flow 2416.

 As illustrated in Figure 25, the shape of the sheathing surface 2414 also may be
15 curved or shaped, e.g., similar to the football shape shown in Figure 25, to further reduce the turbulence caused by blood flow 2416 around the sensor device. The biocompatible sheathing 2408 may be applied to the implanted device 2400 to form the curved surface 2414. Such curves or other shapes may be designed to minimize hydrodynamic forces.

 The encapsulation in a fully biocompatible material, such as silicone may result in
20 very little change in the sensitivity of the pressure sensor. Further, a small offset due to the influence of the encapsulation material may be compensated for during calibration. This may allow, for example, measurements of about +/- 2 mm Hg or less.

 Figure 26 is a side view of a dual substrate sensor embodiment of the invention illustrating how the shape of the sheathing may be configured to minimize turbulence and
25 reactionary fluid forces in the heart. The implantable device 2600 includes a substantially rigid ASIC 2602 having capacitive pressure membranes 2604 and a substrate 2608 with an aperture 2610 substantially opposite the pressure membranes 2604. As illustrated, the device 2600 is encapsulated in a sheathing 2606. The sheathing 2606 may be made of a biocompatible material, such as silicone, that is flexible so that the pressure from the
30 blood may be transmitted to the pressure membranes 2604. A pressure transmitting material (not shown) may be placed in the aperture 2610 to aid in transmitting the pressure. The sheathing 2606 may be shaped, such as an oval or football configuration, to reduce or eliminate hydrodynamic forces from the blood flow 2612. Again, the smallest sides of the device are orientated into the upstream portion of 2112 of the blood flow.

35 Figure 27 is a side view of another embodiment of the invention illustrating how the shape of the sheathing may be configured to minimize turbulence and reactionary fluid

forces in the heart. The device 2700 has the same components as the Figure 26 embodiment and is like-numbered. However, in this embodiment, the sheathing 2706 may be shaped, such as in a rounded triangle configuration, to reduce or eliminate hydrodynamic forces from the blood flow 2712.

5 Figure 28 is a block diagram of the major electronic components of an external reader 2800 of the invention for telemetrically receiving data from an implanted sensor device. An antenna 2802 may be integrated with the external reader 2800, as shown schematically in Figures 1-2. Also, as illustrated in Figure 1, the external reader 12 may be attached to the patient, or alternatively, as illustrated in Figure 2, the external reader 26
10 may be incorporated inside a handheld device. In other cases, the antenna 2802 may be attached to the patient's body or connected to the external reader 2800 by cable connections. Another method attaches the external reader to the patient's bed or seat. Numerous such arrangements may be employed to adapt to the particular application, as the skilled artisan will recognize.

15 The antenna 2802 is used for receiving data, in the form of digital signals, from the implanted sensor device. The digital signals are received at the RF receiver 2806 via an RF generator 2804. The RF generator 2804 generates an RF signal to be transmitted via the antenna 2802 to power the implanted device.

The digital data signals received by RF receiver 2806 are processed by filter 2808
20 and demodulator 2810 before being received and then processed as appropriate by controller 2812. A bidirectional power module 2828, described in detail below, is connected between the filter 2806 and demodulator 2810. Separate memory devices, such as calibration memory 2822, data memory 2824, and parameter memory 2826, may be provided and communicate with controller 2812. The calibration memory 2822 stores
25 calibration information associated with a particular ASIC sensor system, and the calibration memory 2822 may store calibration information for a number of different ASIC sensor systems. Calibration information may be obtained from an external source, such as a computer, through communications port 2816. The appropriate calibration information, based on a unique identification number of the ASIC sensor system being
30 interrogated, is obtained from the calibration memory 2822. Thus, a medical professional, such as a doctor or nurse, can use one reader to obtain pressure readings from multiple patients.

The data memory 2824 stores data related to the pressure and/or temperature received from the ASIC of the implanted sensor device. The data may be stored in the
35 data memory 2824, and then transferred, via a data memory module 2814, to another device through data communications port 2816, such as a computer. Using information

obtained from an atmospheric pressure module 2820, the controller 2812 uses the data received from antenna 2802 and stored in data memory 2824 to determine the pressure within the heart, as is known in the art. Using the information from the ambient temperature module 2818, the controller 2812 also uses the data to determine the
5 temperature within the heart, as is known in the art.

The pressure and temperature calculations, which are performed in controller 2812, as well as the data from the implanted sensor device, may be stored in the data memory module 2814. These calculations and data may then be communicated to another device, such as a computer through communications port 2816.

10 The pressure sensor readings, and the parameter alerts described below, may be displayed by the reader on a display (not shown), such as an LCD display or the like. The measured pressure values and parameter alerts also may be displayed on a monitor of the external reader (not shown) and recorded in an appropriate storage device. The system may be equipped for purposes of telemedicine, so that data is transmitted from the
15 external reader to a medical department or healthcare provider via wire connection, telephone, internet or any other suitable telecommunication source is possible, via known wired or wireless protocols.

The parameter memory 2826 stores parameter thresholds. The data received from the implanted sensor device is compared by the controller 2812 to the parameter
20 thresholds. If the data fails to meet a particular threshold, or exceeds a particular threshold, an alarm may occur to alert a user. The threshold parameters may be set by a doctor or other health care professional. By way of example, the threshold range for pressure may set to 25 to 30 mm Hg, depending on the patient. If the reader receives a measurement of 25 mm Hg, which is above the threshold range, it alerts the user that the
25 measurement exceeds the threshold. Further, an alert may occur based on the raising of pressure per time. Other parameters may also be used.

The parameter thresholds may be provided to the external reader 2800, such as by a user manually entering a parameter threshold. Alternatively, the parameter thresholds may be provided to the external reader 2800 from another device, such as
30 computer through communications port 2816. The parameter thresholds may be provided via a direct connection, such as by a wire, or by a wireless connection, such as by a LAN, a WAN or the like.

The calibration memory 2822, the data memory 2824 and the parameter memory 2826 may be separate memory storage devices within the external reader, or each may
35 be a portion of a single memory storage device. The reader may use a signal at 13.56

MHz, or other known frequencies. One example of a suitable reader is disclosed in published patent application No. PCT/EP2004/012670.

Bi-directional power evaluation module 2828 assists in evaluating the strength of signals received from the implanted device to ensure that a minimum signal strength is received. The signal received from the implanted devices via antenna 2802 is evaluated by the bi-directional power evaluation module 2828. The evaluation may be implemented via various methodologies. According to an embodiment of the invention, the reader may increase the power of the signal sent via the antenna 2802 to the implanted device over small increasing increments. At each increment, the bi-directional power evaluation module 2828 evaluates the signal received back from the implanted device to determine the quality and strength of the signal. This process is repeated until a successful signal is received from the implanted device. The reader then uses the minimum power necessary to achieve an acceptable signal and begins performing the reading of data, such as pressure and temperature measurements, from the device. This may be performed by taking a predetermined number of readings (e.g., five readings) in a row. All the readings may be taken after the minimum power level has been determined. Alternatively, the bi-directional power evaluation module 2828 may determine the minimum power level after each of the predetermined readings.

By way of another embodiment of the invention, the reader can increase the power level supplied by the antenna 2802 by larger increments, such as by quarter Fourier steps (FS steps), until a valid signal is received from the implanted device. Once a valid signal is obtained, the power is decreased by one step, such as $\frac{1}{4}$ FS, then increased in smaller steps, such as $\frac{1}{8}$ FS steps) until a valid signal is received. This process is repeated using progressively smaller steps ($\frac{1}{16}$ FS, $\frac{1}{32}$ FS) until a minimum power level is determined. The reader then uses the resulting minimum power level to compute the required power setting and obtains a predetermined number of readings.

Another methodology involves assessing the demodulation quality level (DQL) of the signal in addition to the signal state analysis described above. The DQL of a signal changes as the coil geometry and/or distance from the reader changes. It does not use an incremental algorithm to assess the required starting power, but the last power setting of the last measurement. The reader sets the power to a previously used level. If a reading is possible, the reader increases or decreases the power for the next reading according to DQL. If no reading is possible, the reader increases the power in increments until valid signal is received from the implanted device. After a predetermined number (e.g., five) of successful readings, the reader obtains the measurement readings. During these

measurement readings, the reader continues to increase, decrease, or hold the power level according to DQL and obtaining valid signals.

Use of power conditioning may result is various beneficial characteristics and features for the voltage controller/stabilizer supply voltage (V_{DDA}) used in the ASIC. When
5 using power conditioning, there is generally a high common mode rejection ratio (CMRR) for V_{DDA} , as well as good radio frequency (RF) suppression for V_{DDA} . In addition, a fast power on reset (POR) signal is used if V_{DDA} falls below tolerance, which would happen if supply power is not sufficient. Because there is no measurement or signal transmission if POR not "1," determining a proper power supply using the power conditioning may
10 prevent this drawback.

The implantable sensor device of the invention also may be incorporated or attached to other devices implanted within the body. Examples of such devices may include a pacemaker, defibrillator or a drug dispenser.

While the invention has been described in terms of exemplary embodiments, those
15 skilled in the art will recognize that the invention can be practiced with modifications in the spirit and scope of the appended claims. For example, while the embodiments described above have been directed to implantation of the telemetric sensing device of the invention within the heart, one or more such devices may be implanted within other positions in the cardiovascular system of a patient, such as the aorta, pulmonary artery, or any of the
20 other great vessels. These examples given above are merely illustrative and are not meant to be an exhaustive list of all possible designs, embodiments, applications or modifications of the invention.

WHAT IS CLAIMED IS:

1. An intra-cardiac pressure measuring system for measuring blood pressure inside the heart of a patient, said system comprising:

5 an antenna;

an integrated chip including a first substantially rigid substrate, at least one pressure sensor disposed within said substrate to generate signals indicative of a sensed pressure, and electronic signal processing components to process the signals generated by said at least one pressure sensor, said electronic signal processing components being
10 operatively connected to said antenna, said integrated chip being powered by a signal received at said antenna;

an implantable holder supporting said integrated chip, said holder including an anchor structure to mount said integrated chip within a wall of the heart during surgery such that said at least one pressure sensor is exposed to blood flow in the heart;

15 a remote receiver; and

wherein said integrated chip is operative to send digital signals indicative of the pressure sensed in the heart telemetrically via the antenna to said remote receiver.

2. The system according to claim 1, wherein said at least one pressure sensor comprises capacitive-based pressure sensitive membranes housed within said
20 substrate.

3. The system according to claim 1, wherein said at least one pressure sensor generates an analog signal in response to a sensed pressure and said electronic signal processing components include at least one analog to digital (A/D) converter to digitize within the heart the analog signals from said at least one pressure sensor.

25 4. The system according to claim 1, further comprising a flexible wire connecting said antenna and said integrated circuit, said antenna being configured to be implanted within the patient underneath the skin to facilitate telemetric data transmission to said receiver.

30 5. The system according to claim 1, wherein said integrated chip weighs less than about one gram, has a surface area on one side of less than or equal to about 10 mm² and has a thickness of less than about 1 mm.

6. The system according to claim 4, wherein said antenna, said chip, said wire, and said holder are encapsulated in a seamless, one-piece biocompatible sheathing.

7. The system according to claim 6, further comprising a pressure transferring medium interposed between said biocompatible sheathing and said at least one pressure sensor.

8. The system according to claim 6, where said biocompatible sheathing acts
5 as a pressure transferring medium to said at least one pressure sensor.

9. The system according to claim 6, wherein said sheathing is shaped to minimize turbulence in blood flow within the heart.

10. The system according to claim 1, wherein said integrated chip further includes a unique digital identification, and wherein said unique digital identification is sent
10 telemetrically to said receiver.

11. The system according to claim 10, wherein said receiver obtains calibration information associated with said integrated chip based on said unique digital identification.

12. The system according to claim 1, wherein said receiver includes a stored parameter and produces an alert based on the signals indicative of the pressure sensed in
15 the heart and of the stored parameter.

13. The system according to claim 1, further comprising a second substantially rigid substrate located opposite said at least one pressure sensor in said first substrate and in a spaced apart configuration, said second substrate protecting said integrated chip from mechanical damage.

14. The system according to claim 13, wherein said second substrate includes
20 an aperture permitting blood flow within the heart to act on said at least one pressure one pressure sensor.

15. The system according to claim 14, further comprising a pressure transferring medium interposed between said at least one pressure sensor and said
25 second substantially rigid substrate to transfer blood pressure to said at least one pressure sensor.

16. The system according to claim 13, further comprising at least one bond pad disposed between said first and second substantially rigid substrates and electrically connected to said integrated chip.

17. The system according to claim 16, further comprising at least one bond
30 tack on said second substantially rigid substrate, wherein said at least one bond tack is connected to said at least one bond pad, and wherein said antenna is operatively connected to said integrated chip via said at least one bond pad and said at least one bond tack to provide a strain relief connection.

18. The system according to claim 13, further comprising an antenna connector to connect said antenna to said second substantially rigid substrate, wherein said antenna connector comprises a signal portion electrically connecting said antenna to said integrated chip and a support portion connected to said second substantially rigid substrate.

19. The system according to claim 18, wherein said antenna connector is attached to said second substantially rigid substrate such that there is slack in said signal portion when said support portion is taut.

20. The system according to claim 19, wherein said signal portion is connected to said integrated chip via said at least one bond tack and said support portion is connected to said second substantially rigid substrate via an opening in said second substantially rigid substrate.

21. The system according to claim 18, wherein said at least one bond tack comprises at least two bond tacks disposed on opposite sides of said aperture.

22. The system according to claim 13, wherein said second substantially rigid substrate includes a protective barrier connected thereto, and further comprising a biocompatible sheathing encapsulating at least said integrated chip and said second substantially rigid substrate, wherein said protective barrier is disposed to prevent said first substantially rigid substrate from puncturing said biocompatible sheathing.

23. The system according to claim 13, further comprising a flexible support material between said integrated chip and said second substantially rigid substrate.

24. The system according to claim 1, wherein said holder and said first substantially rigid substrate are integrally formed into a single piece.

25. The system according to claim 1, wherein said antenna is supported by said holder.

26. The system according to claim 1, wherein said holder includes a stop that limits the movement of said integrated chip into the heart chamber.

27. The system according to claim 1, wherein said integrated chip and said holder are removable from the heart after implantation.

28. The system according to claim 1, wherein said at least one pressure sensor comprises a plurality of pressure sensors including at least one active sensor responsive to changes in pressure within the heart and at least one passive sensor that is isolated from the changes in pressure within the heart; and

wherein said electronic signal processing components provide a signal based at least in part on a signal from said at least one active pressure sensor and a signal from said at least one passive pressure sensor.

29. The system according to claim 28, wherein the structure of said active
5 pressure sensor is substantially the same as a structure of said passive pressure sensor.

30. The system according to claim 28, wherein said plurality of pressure sensors comprise capacitive pressure sensors each having a flexible movable membrane.

31. The system according to claim 30, wherein the passive pressure sensor
10 signal is responsive to a change in position of said membrane of said passive pressure sensor and the change of position of said membrane of said passive pressure sensor is due to a drift effect comprising a sag of said membrane.

32. The system according to claim 31, wherein a change of position of said membrane of said active pressure sensor is due to:

15 a change in pressure within the heart; and
a drift effect comprising a sag of said membrane.

33. The system according to claim 28, wherein said pressure signals are the result of offsetting the signal from said at least one active pressure sensor with the signal from said at least one passive pressure sensor.

34. A method of sensing blood pressure within the cardiovascular system of a
20 subject, said method comprising the steps of:

- (a) implanting within the subject an integrated chip including a substantially rigid substrate and at least one capacitive-based pressure sensor disposed within said substrate in a position to sense blood pressure within the cardiovascular system;
- 25 (b) powering on the integrated chip telemetrically by activating a power source located outside the subject;
- (c) obtaining one or more analog signals from the at least one pressure sensor indicative of the pressure at the position in the cardiovascular system; and
- (d) converting the analog signals to digital signals at or directly
30 adjacent to the position in the cardiovascular system where the sensing occurs.

35. The method according to claim 34, wherein said implanting step comprises implanting an ASIC having a capacitive-based pressure sensor in the heart.

36. The method according to claim 35, further comprising the step of limiting the ASIC from entering the heart chamber with a stop device.

37. The method according to claim 34, wherein the integrated chip includes a unique digital identification, and further comprising the step of telemetrically communicating the unique digital identification to an external reader.

5 38. The method according to claim 37, further comprising the step of obtaining calibration information associated with the integrated chip at the external reader based on the unique digital identification.

39. The method according to claim 34, wherein the integrated chip is supported in a holder and said implanting step comprises the steps of:

10 delivering the holder to the position in the cardiovascular system; and mounting the holder at the position such that the at least one pressure sensor is exposed to the pressure in the cardiovascular system to be sensed.

15 40. The method according to claim 34, wherein the at least one capacitive-based pressure sensor comprises a plurality of capacitive-based pressure sensors including an active pressure sensor and a passive pressure sensor located within the subject in a position to directly sense blood-pressure within a position in the cardiovascular system; and

wherein said step of obtaining one or more analog signals further comprises:

(a) obtaining one or more analog signals from the active pressure sensor indicative of the pressure at the position in the cardiovascular system;

20 (b) obtaining one or more analog signals from the passive pressure sensor indicative of the pressure at the position in the cardiovascular system; and

(c) generating one or more combined analog signals based on the one or more analog signals from the active pressure sensor and the one or more analog signals from the passive pressure sensor indicative of the pressure at the position in the cardiovascular system.

41. The method according to claim 40, wherein said step of converting the analog signals further comprises converting the combined analog signals to digital signals.

30 42. The method according to claim 40, wherein said step of generating said one or more combined analog signals includes offsetting the signal from said active pressure sensor with the signal from said passive pressure sensor.

43. An integrated chip for intra-cardiac blood pressure measurement inside the heart of a patient, said integrated chip comprising:

a first substantially rigid substrate;

at least one pressure sensor disposed within said substrate to generate signals indicative of a sensed pressure;

electronic signal processing components to process the signals generated by said at least one pressure sensor, said electronic signal processing components being
5 operatively connected to an antenna, said integrated chip being powered by a signal received at the antenna; and

wherein said integrated chip is operative to send digital signals indicative of the pressure sensed in the heart telemetrically via an antenna to a remote receiver.

44. The integrated chip according to claim 43, wherein said at least one
10 pressure sensor generates analog signals and said electronic signal processing components include at least one analog to digital (A/D) converter to digitize within the heart the analog signals from said at least one pressure sensor.

45. The integrated chip according to claim 43, wherein said integrated chip
15 weighs less than about one gram, has a surface area on one side of less than or equal to about 10 mm² and has a thickness of less than about 1 mm.

46. The integrated chip according to claim 43, further comprising a second substantially rigid substrate located opposite said at least one pressure sensor in said first substrate and in a spaced apart configuration.

47. The integrated chip according to claim 46, wherein said second substrate
20 includes an aperture permitting blood pressure within the heart to act on said at least one pressure one pressure sensor.

48. The integrated chip according to claim 47, further comprising a pressure
25 transferring medium interposed between said at least one pressure sensor and said second substantially rigid substrate to transfer blood pressure to said at least one pressure sensor.

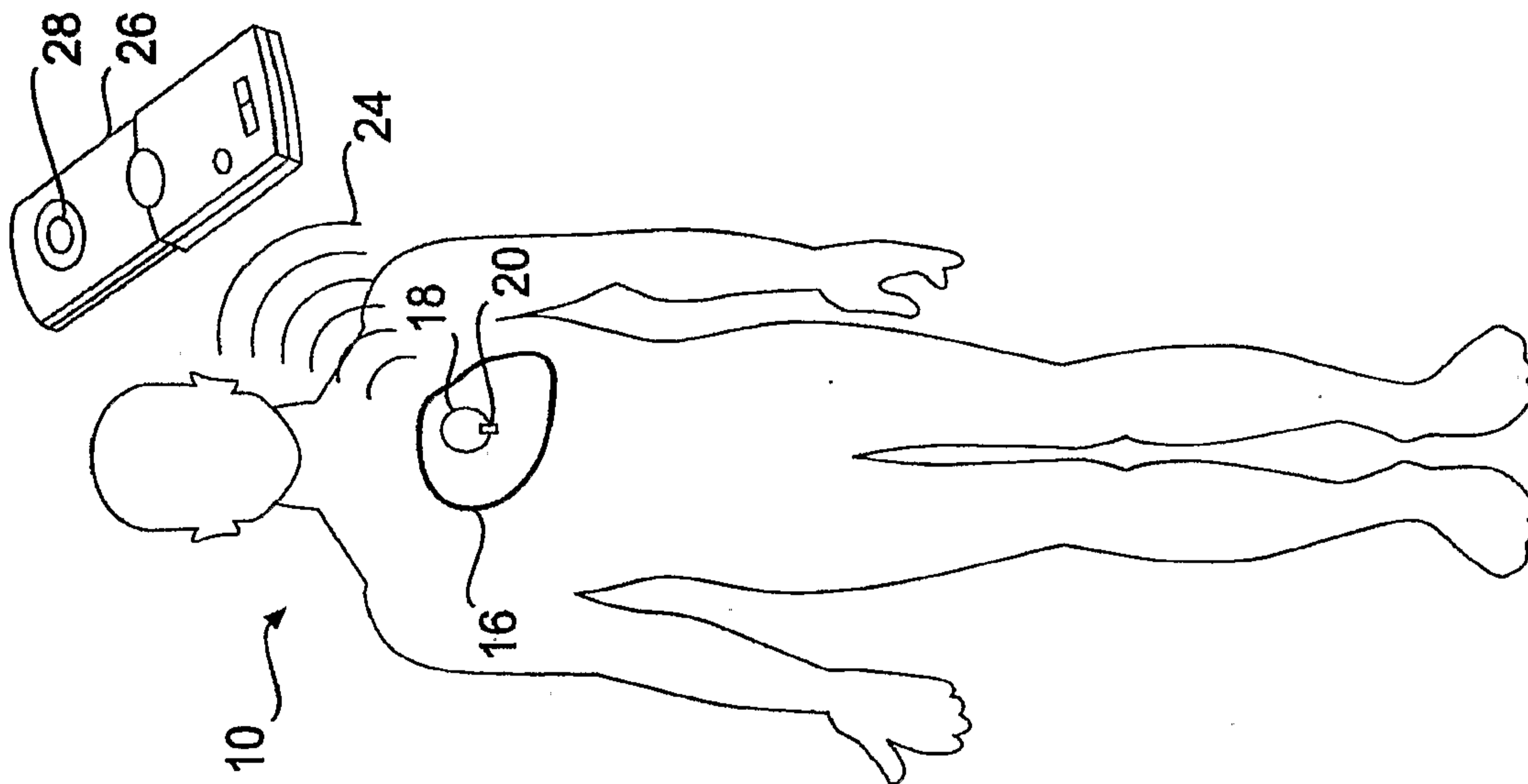

FIG. 2

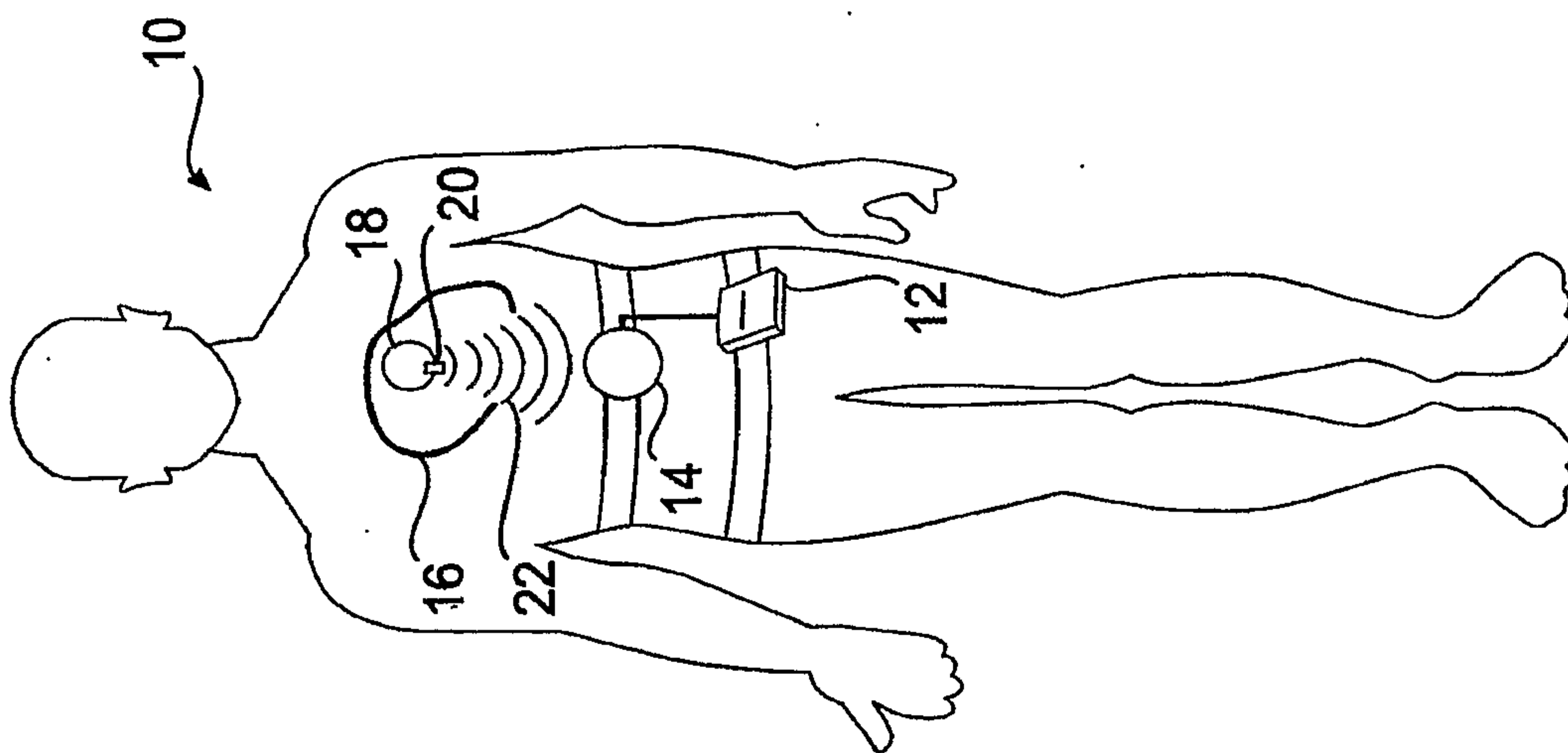

FIG. 1

2/19

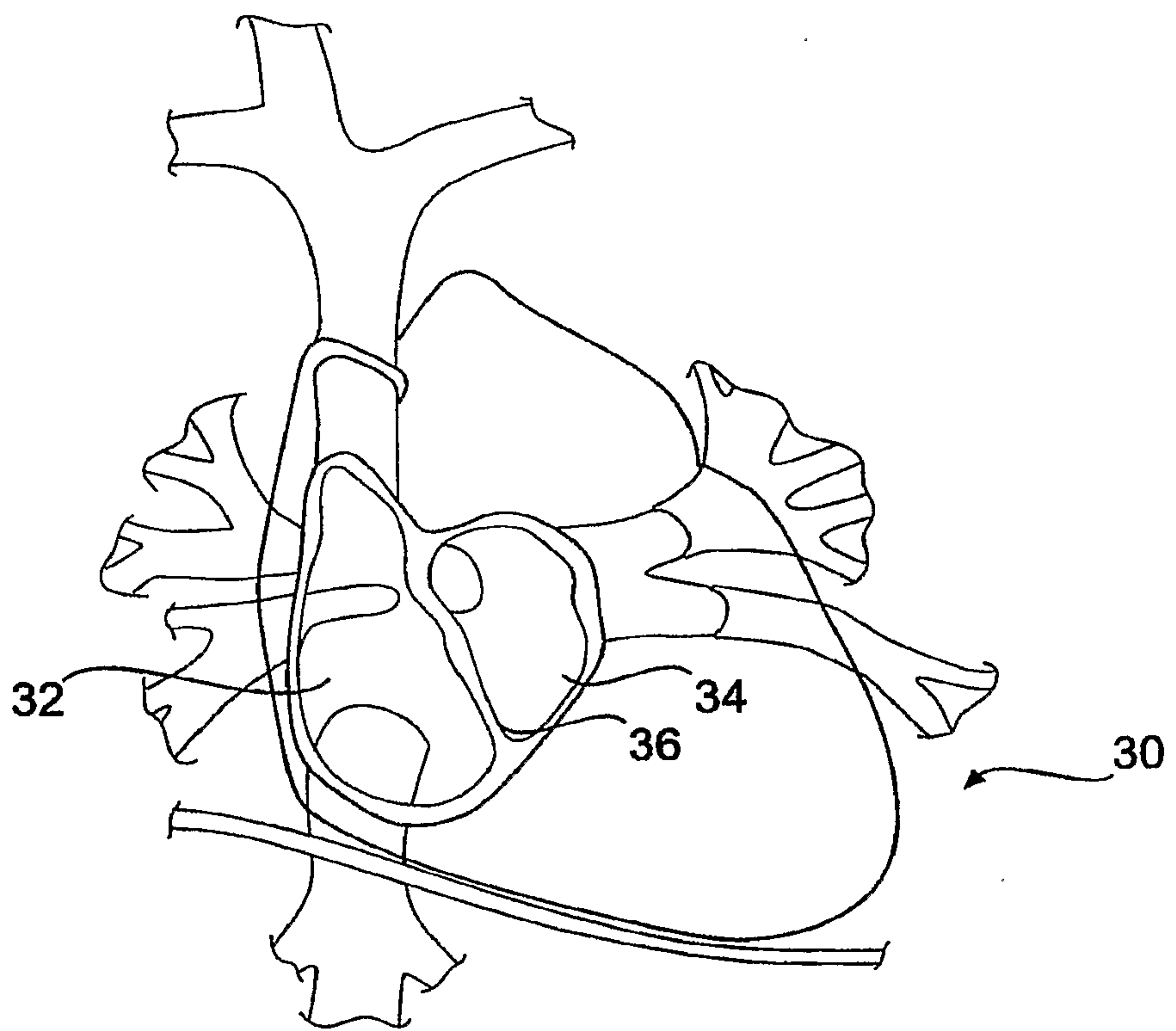

FIG. 3

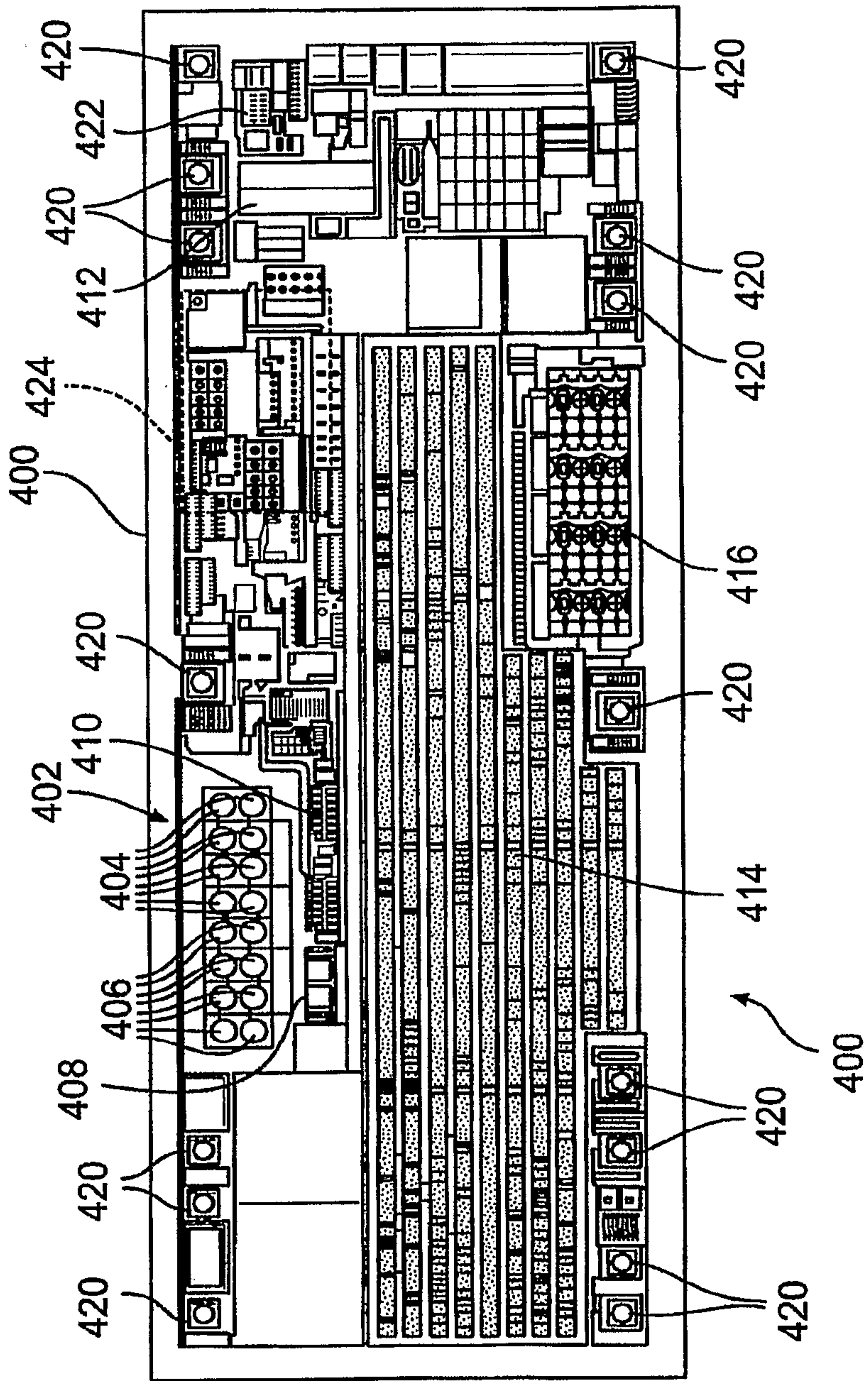

FIG. 4

4/19

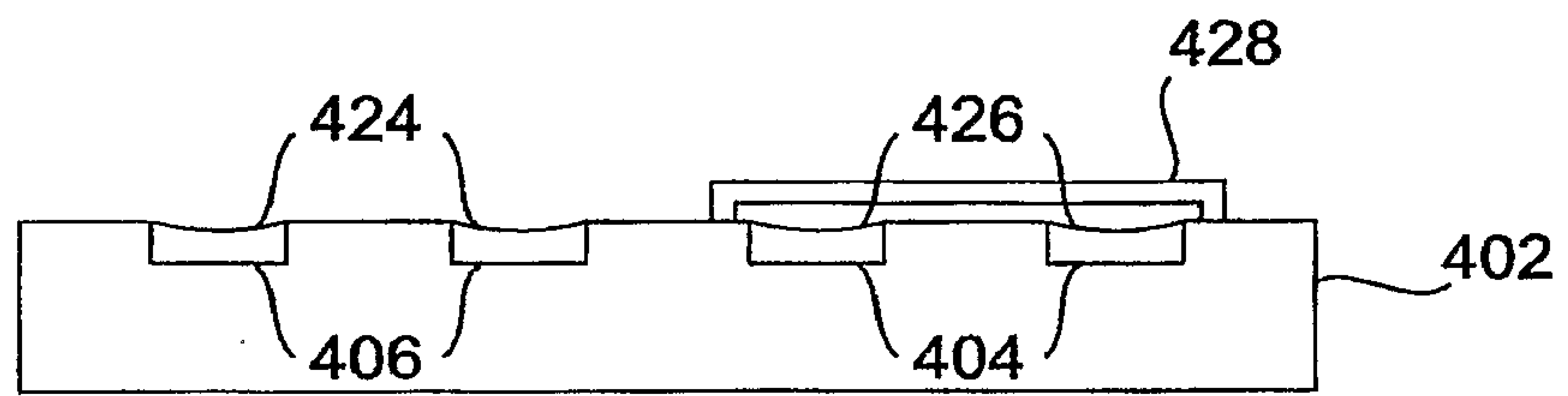

FIG. 5

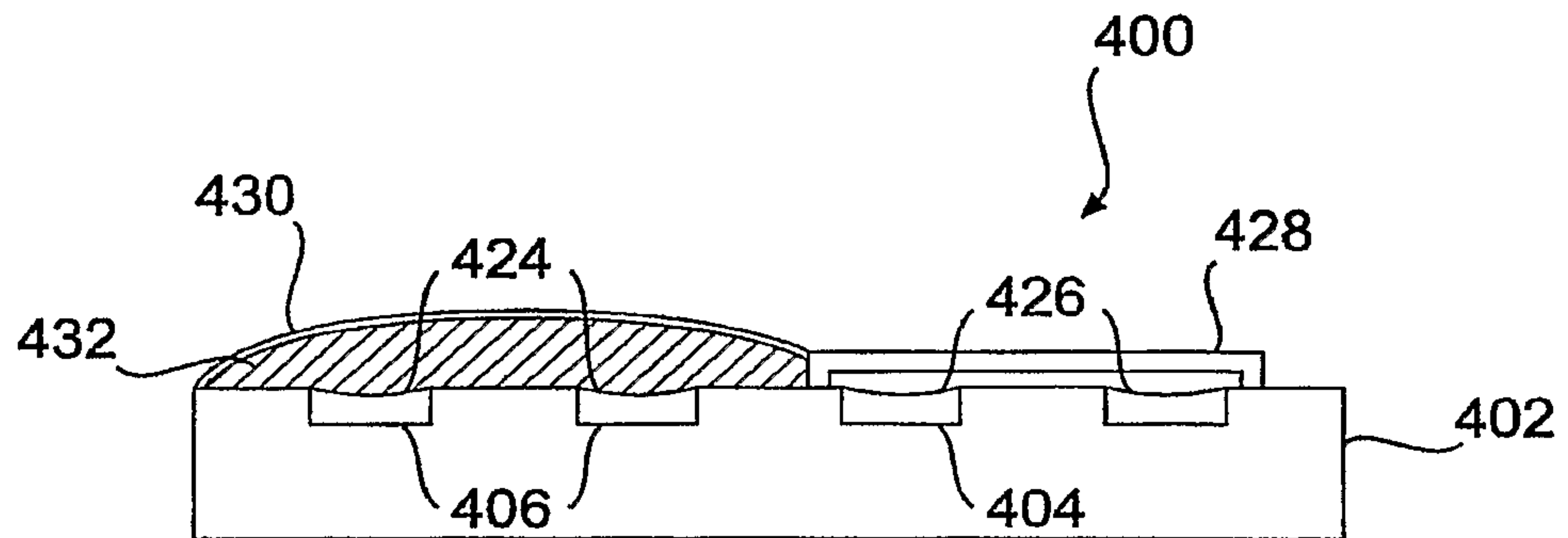

FIG. 6

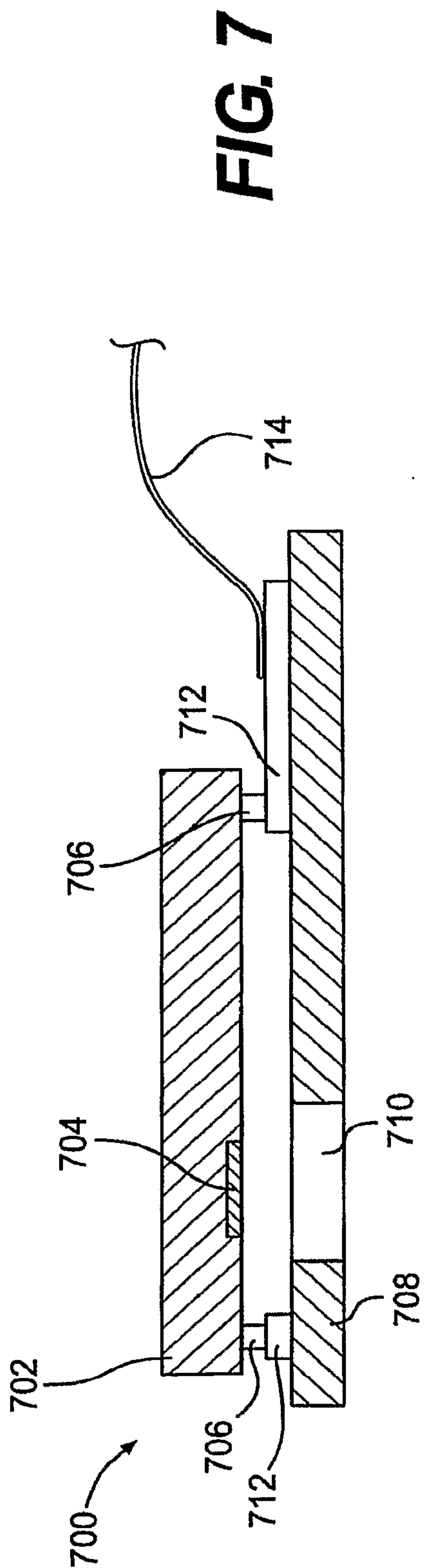

FIG. 7

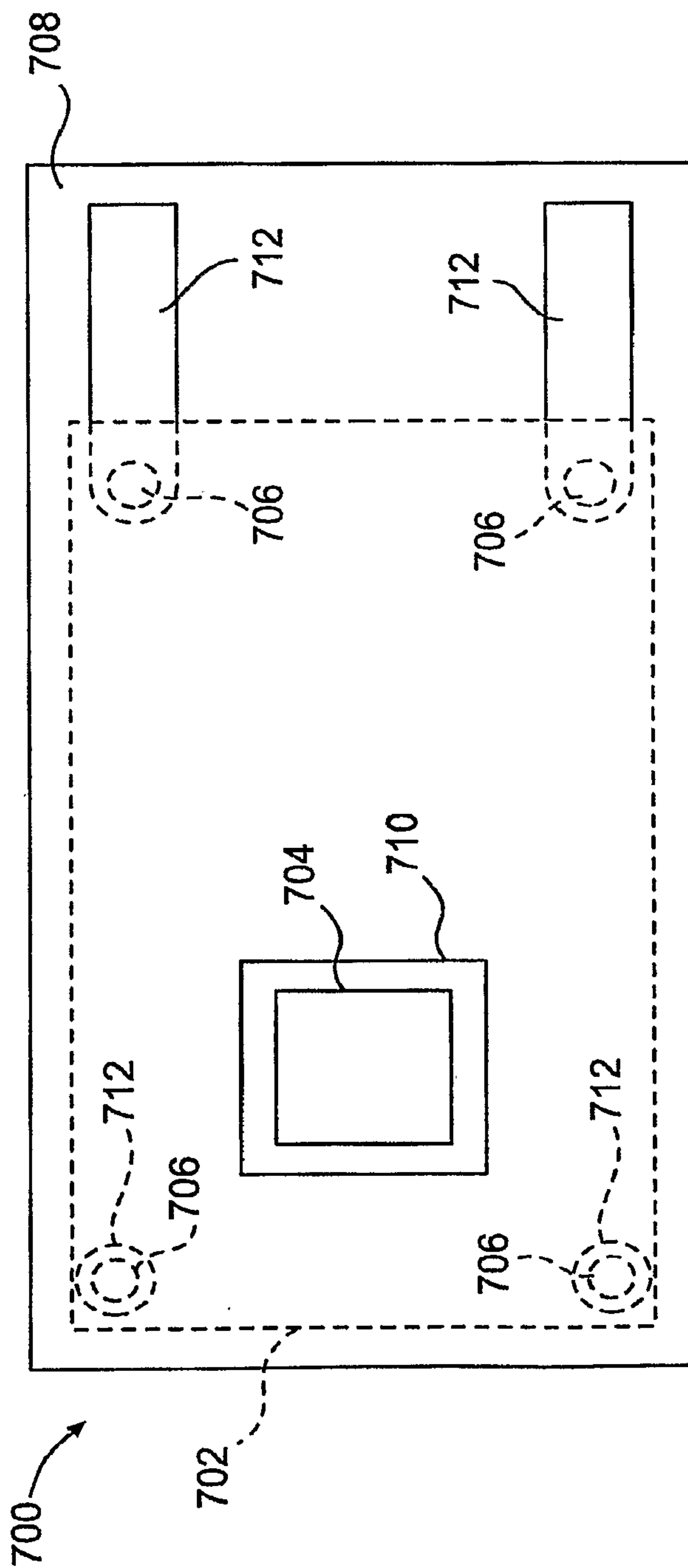

FIG. 8

FIG. 9

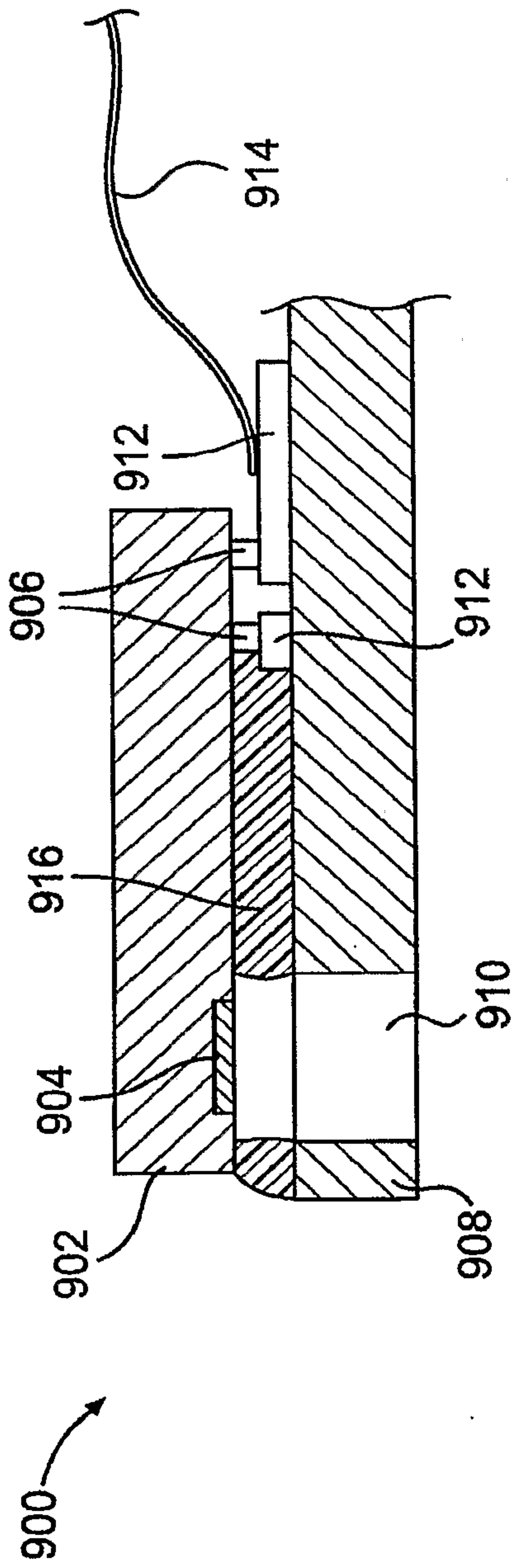
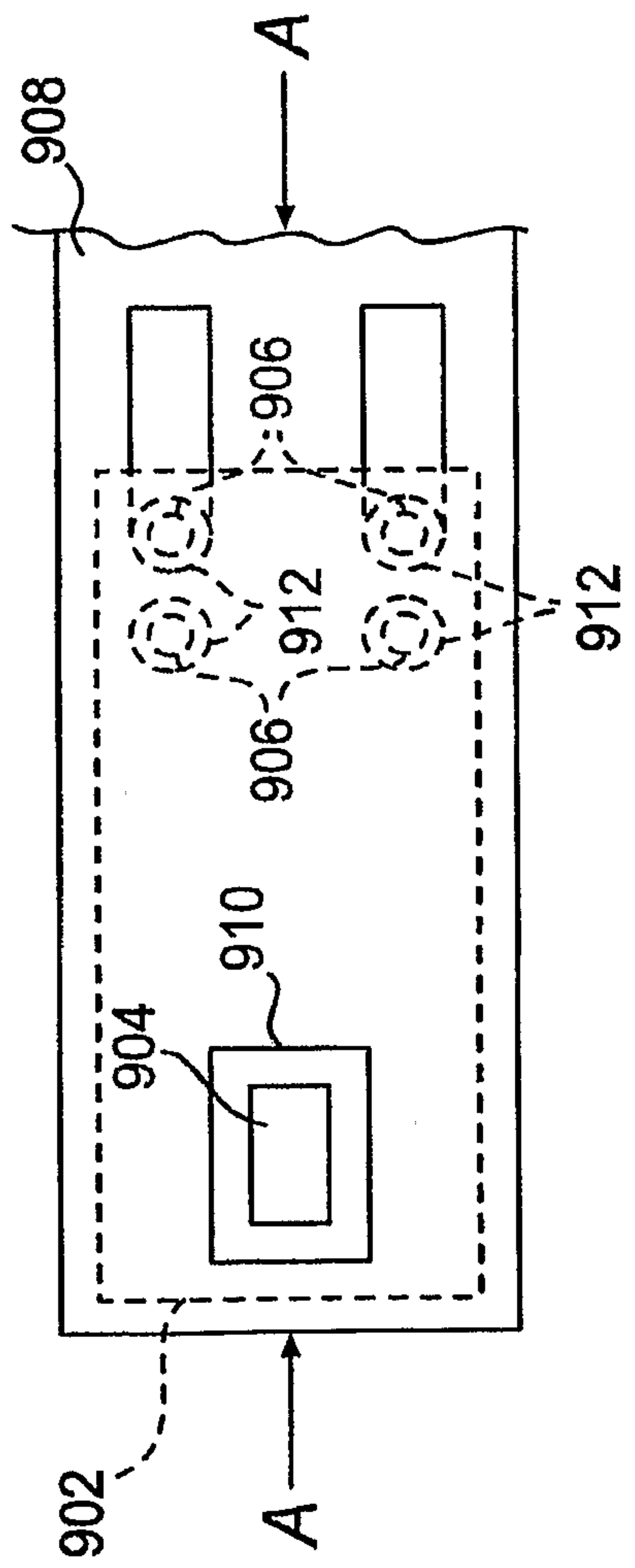

FIG. 10



7/19

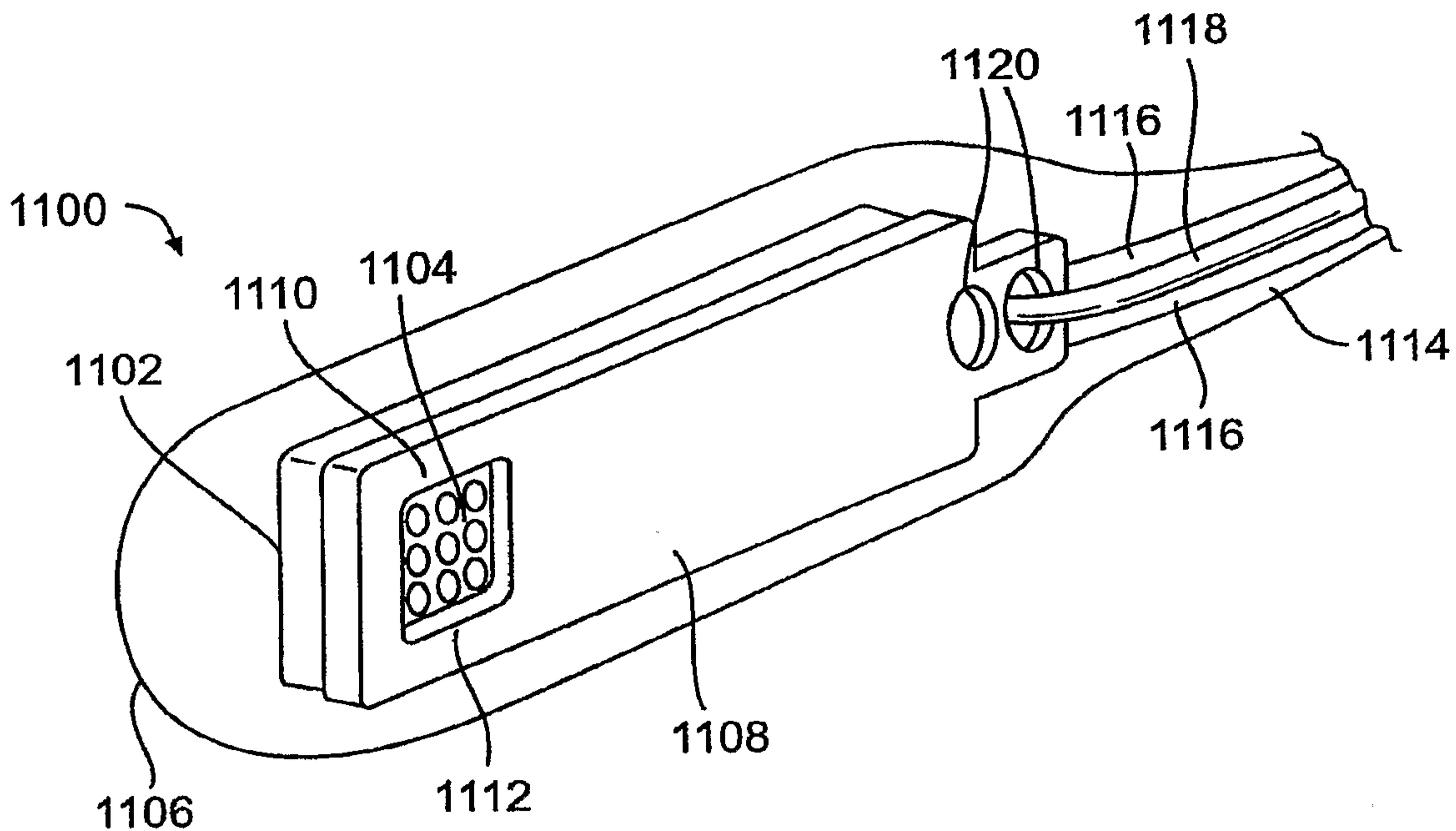

FIG. 11

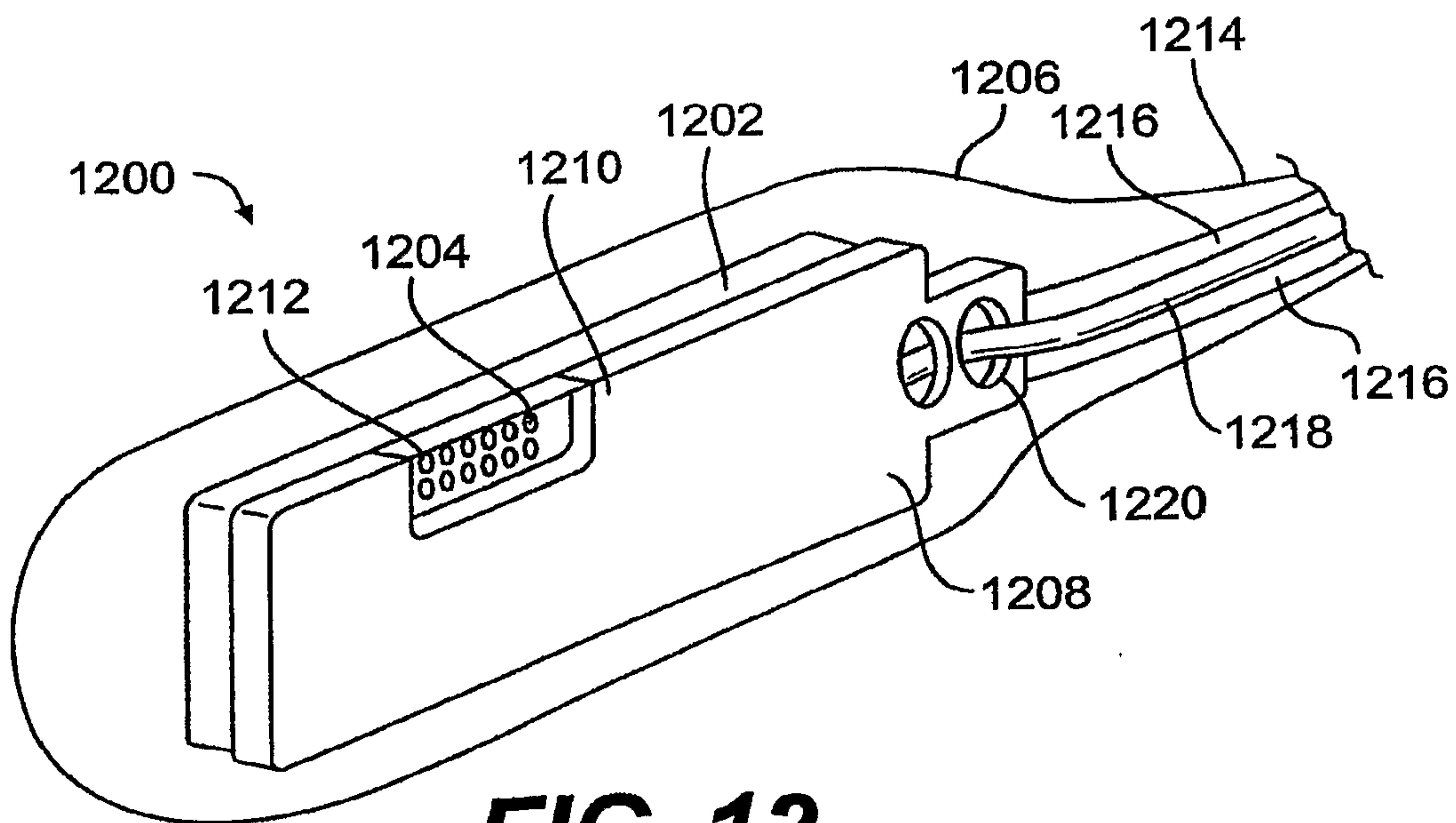

FIG. 12

8/19

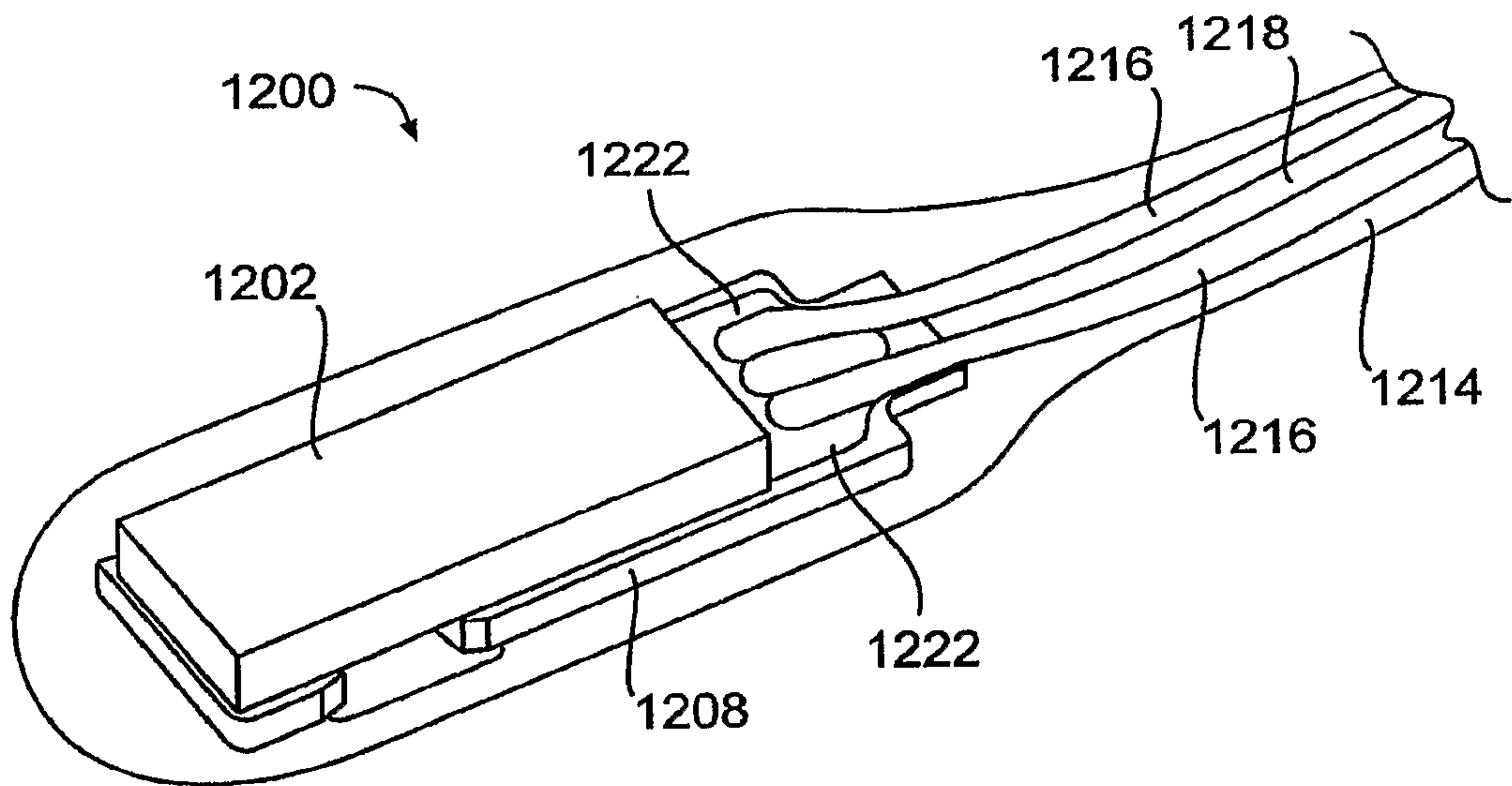

FIG. 13

9/19

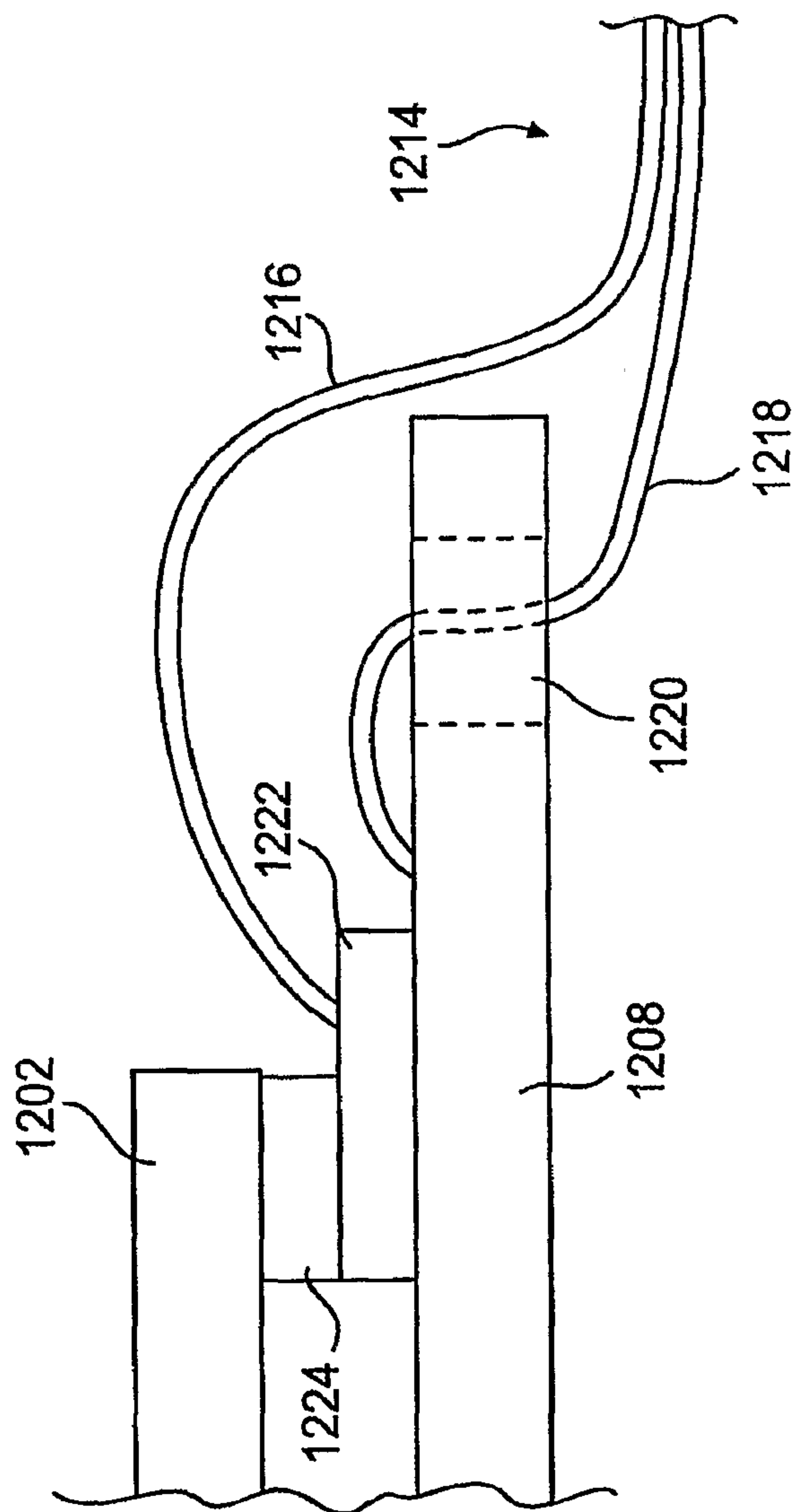

FIG. 14

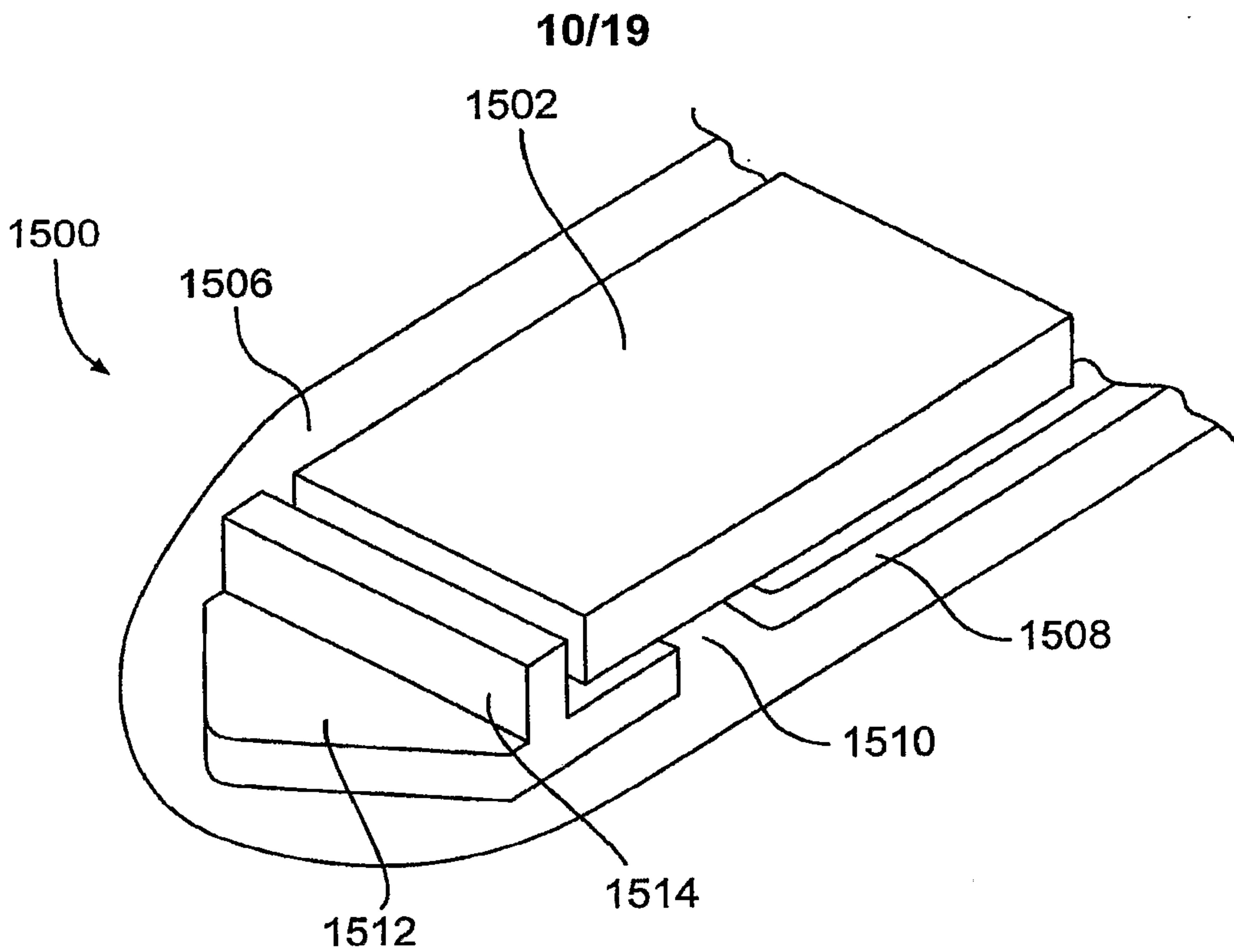

FIG. 15

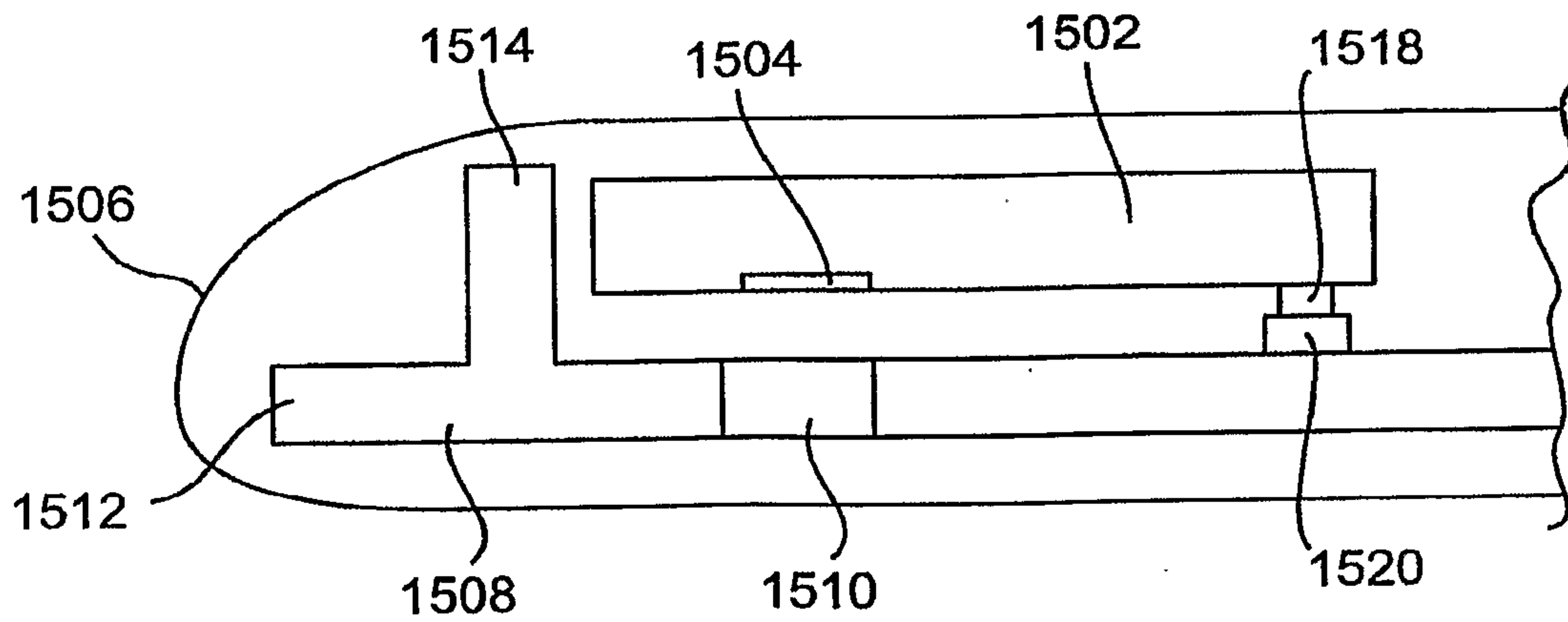

FIG. 16

11/19

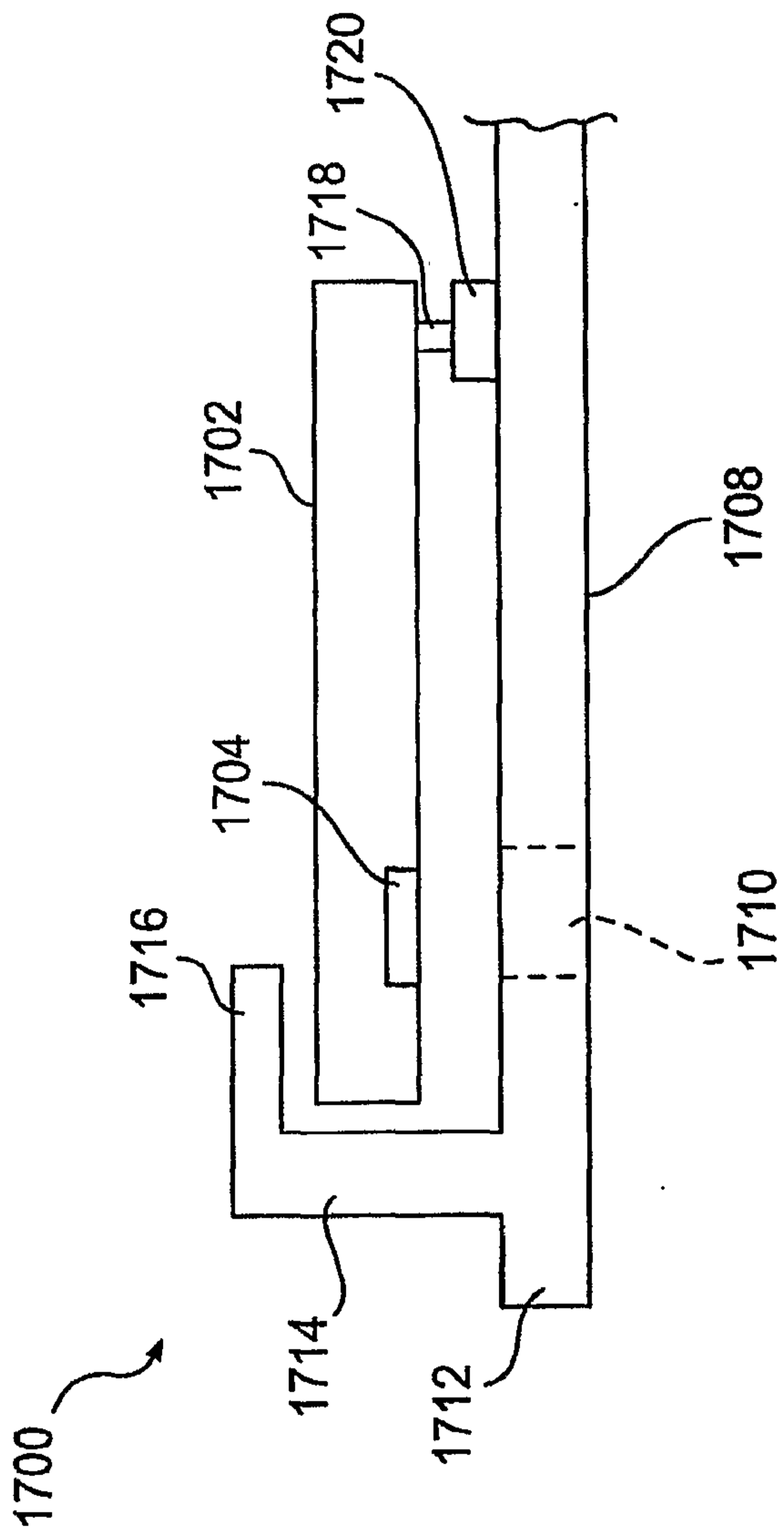

FIG. 17

12/19

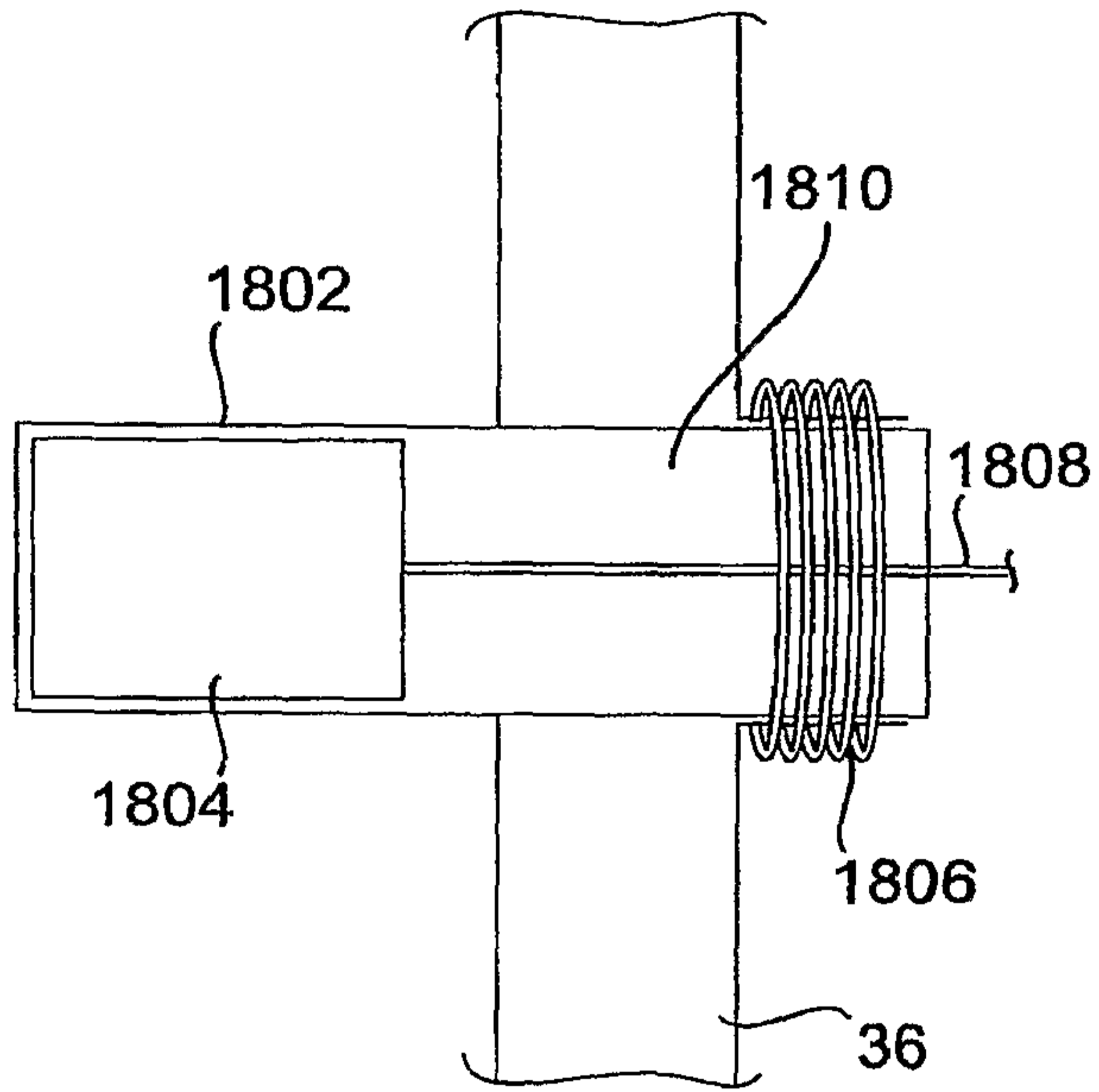

FIG. 18

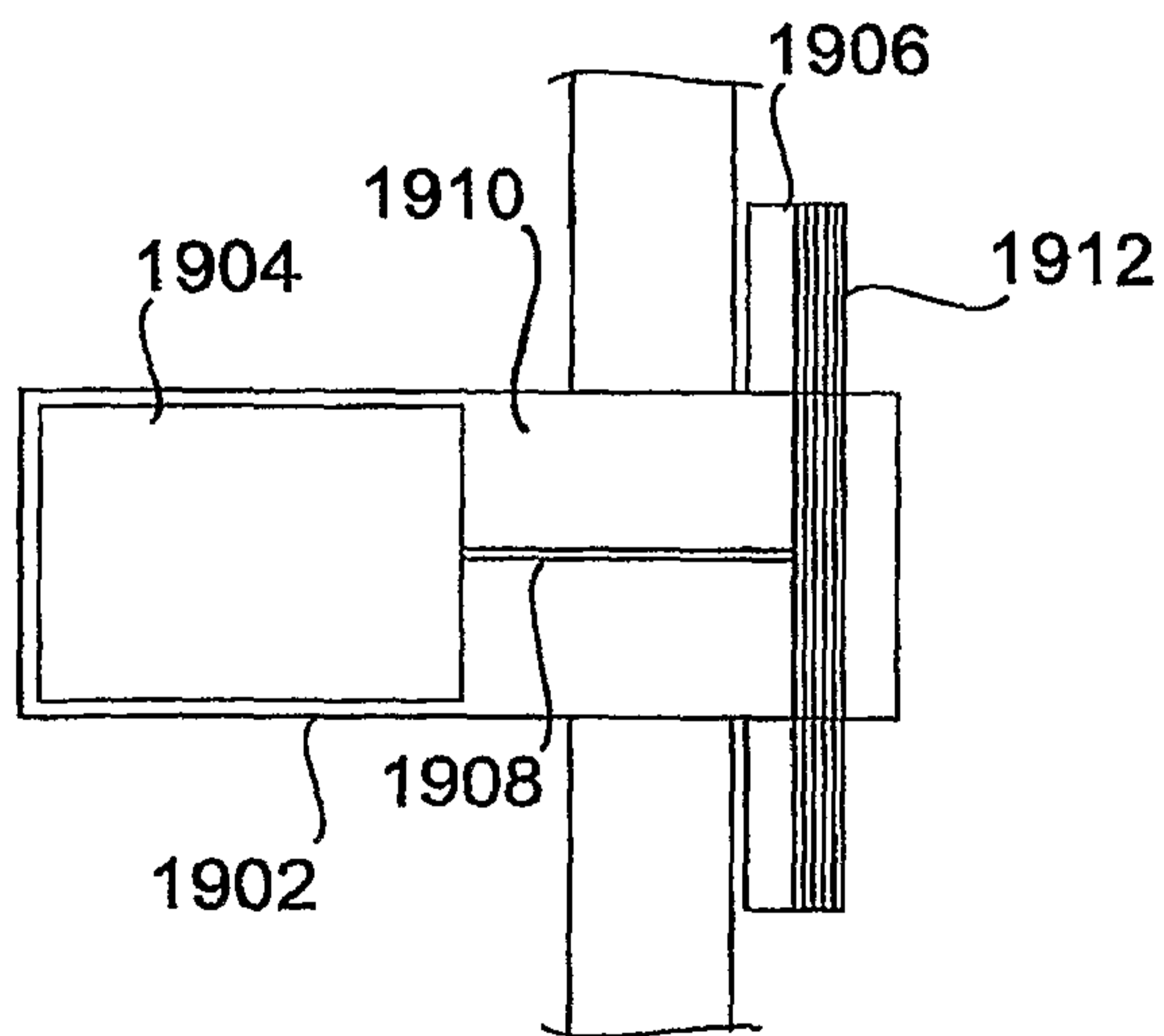

FIG. 19

13/19

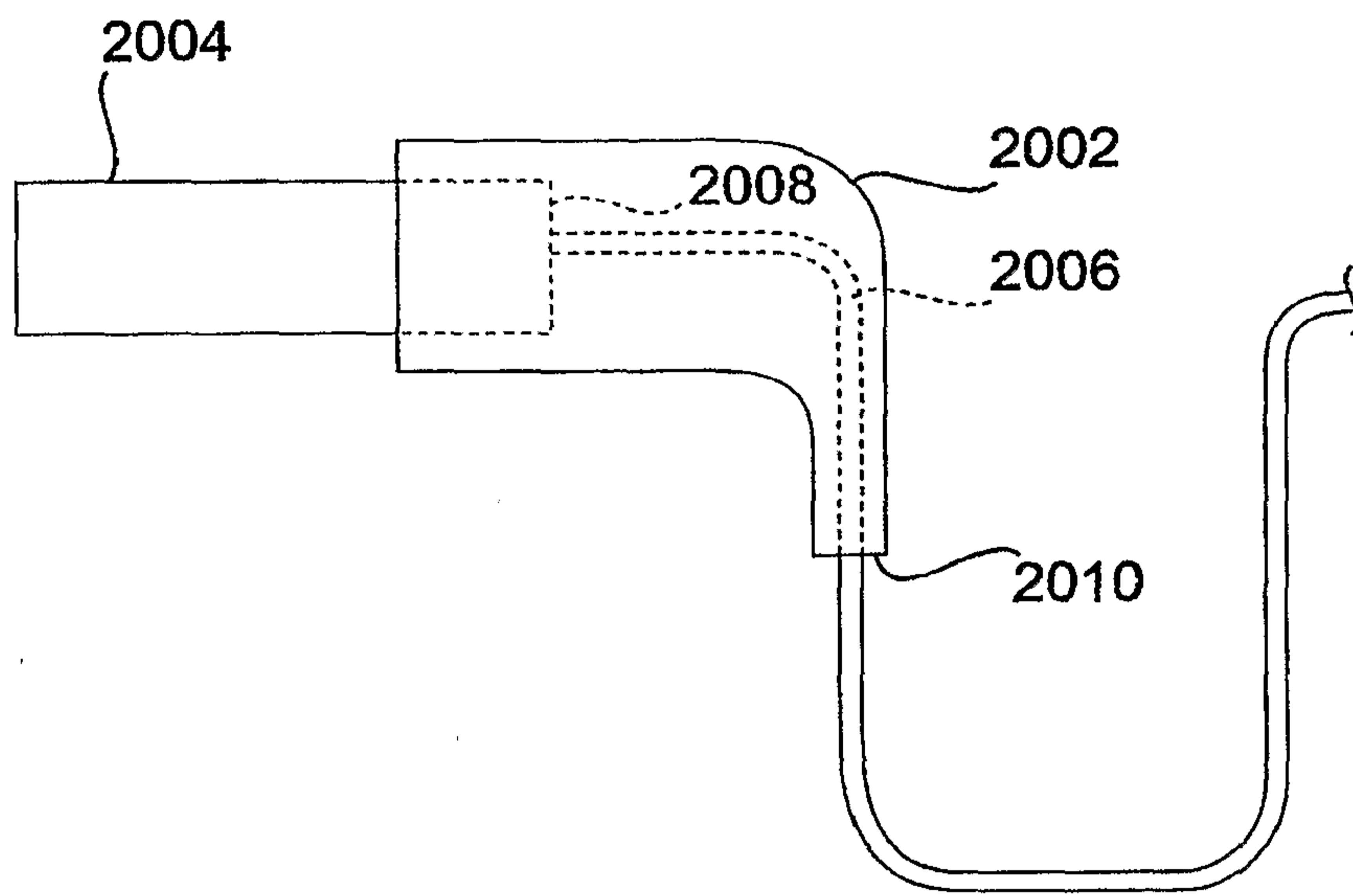

FIG. 20

14/19

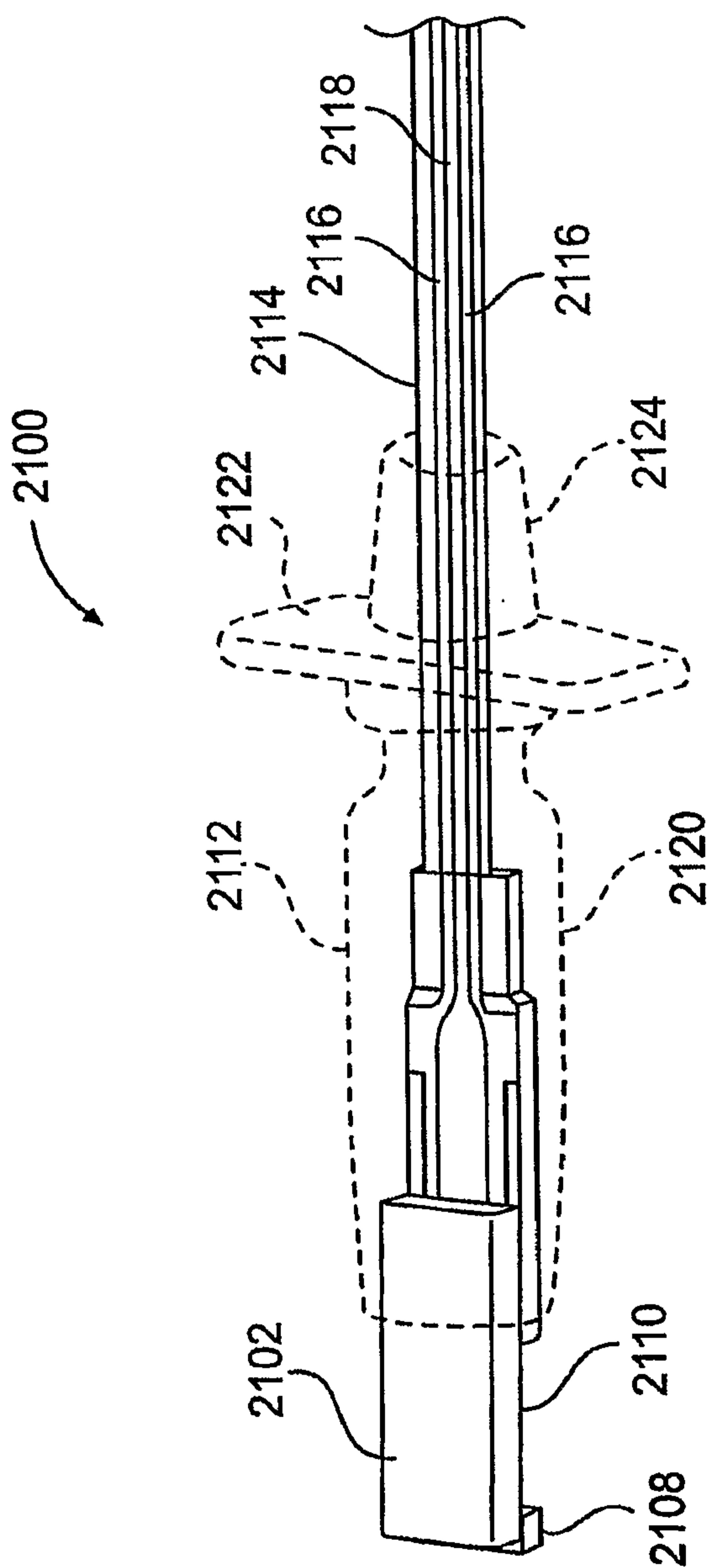

FIG. 21

15/19

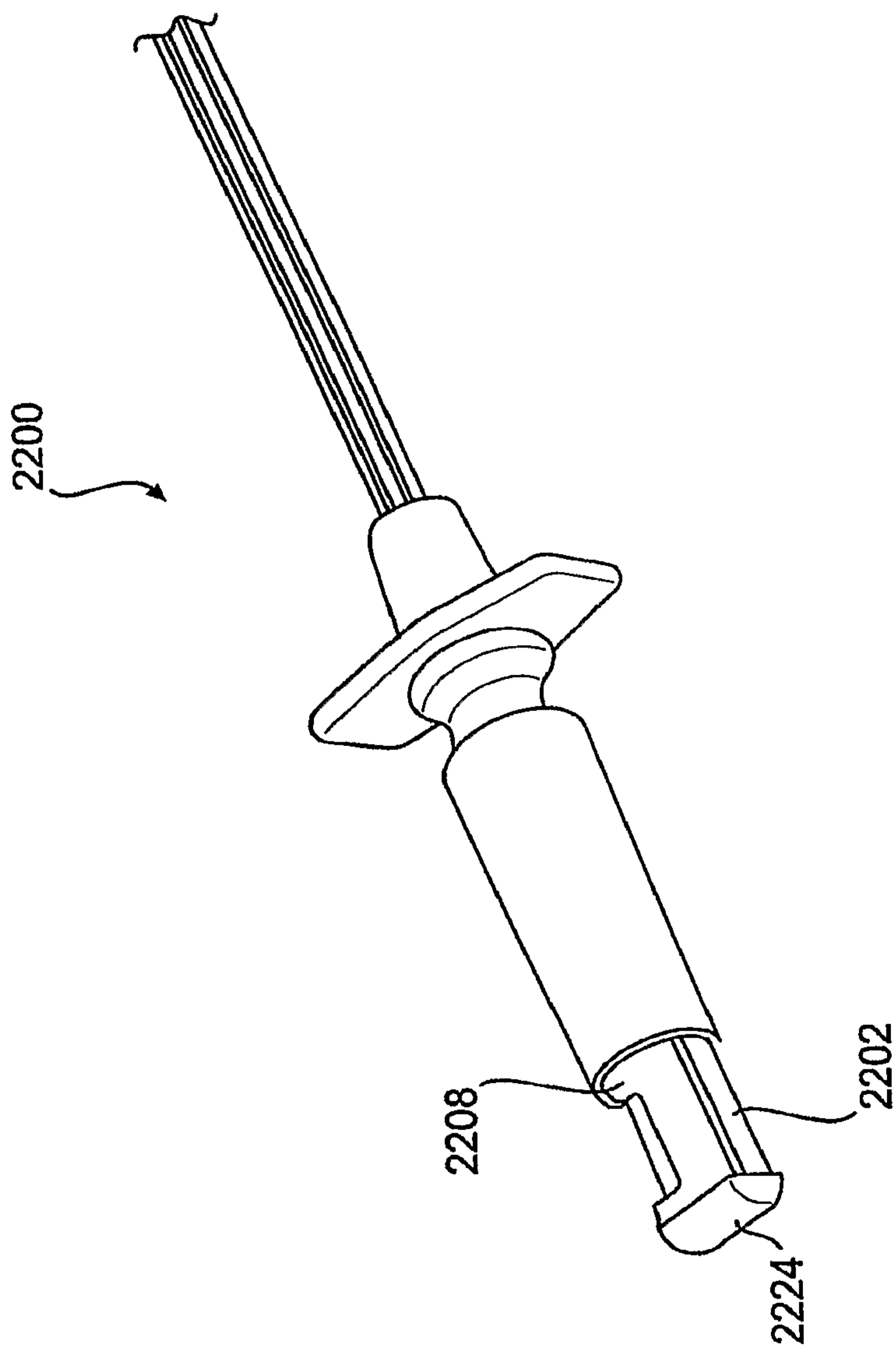

FIG. 22

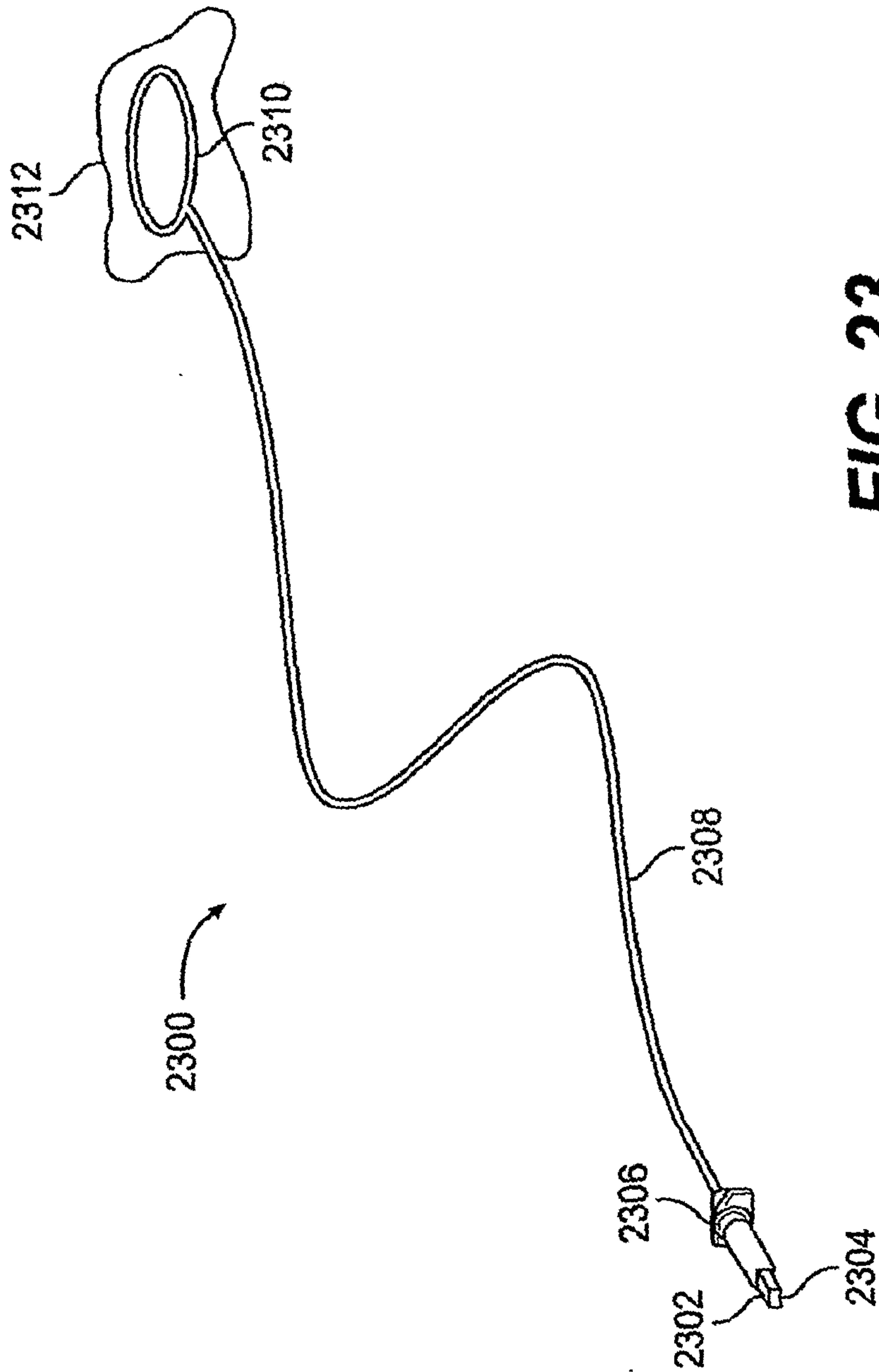

FIG. 23

17/19

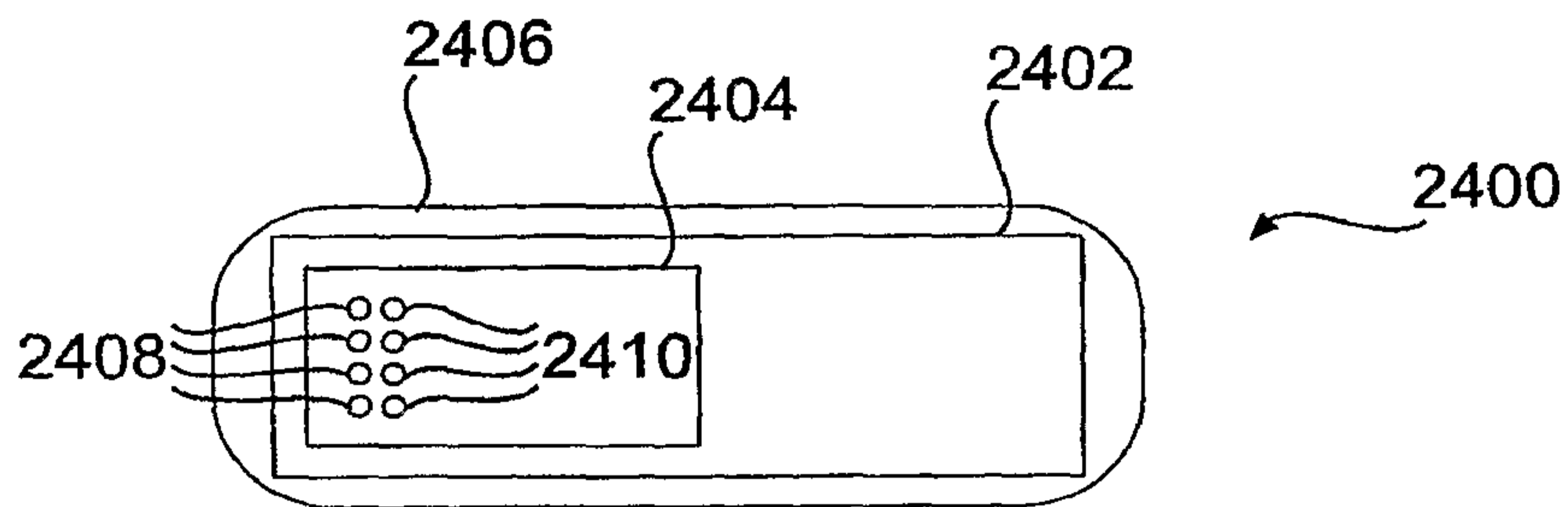

FIG. 24

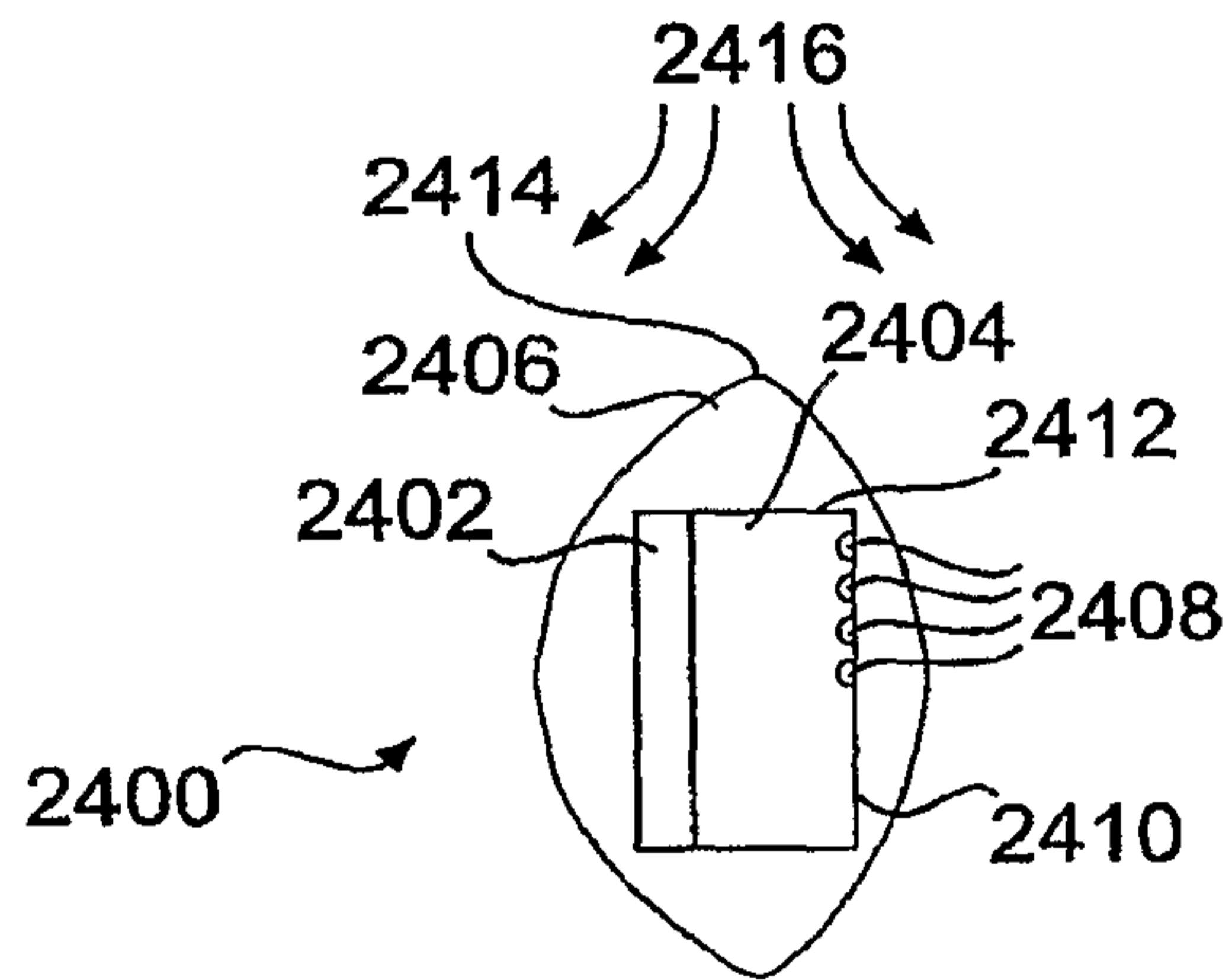

FIG. 25

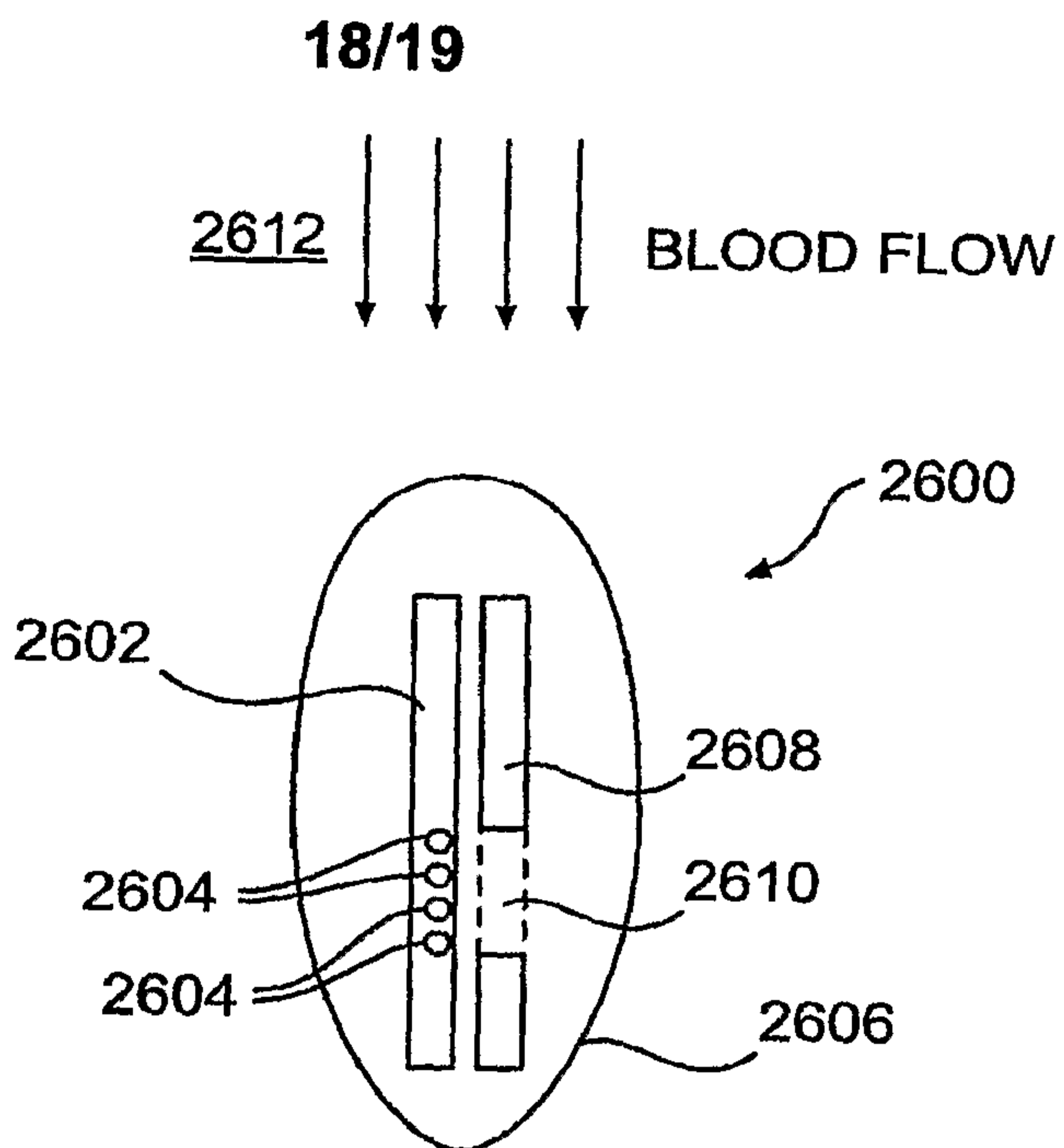

FIG. 26

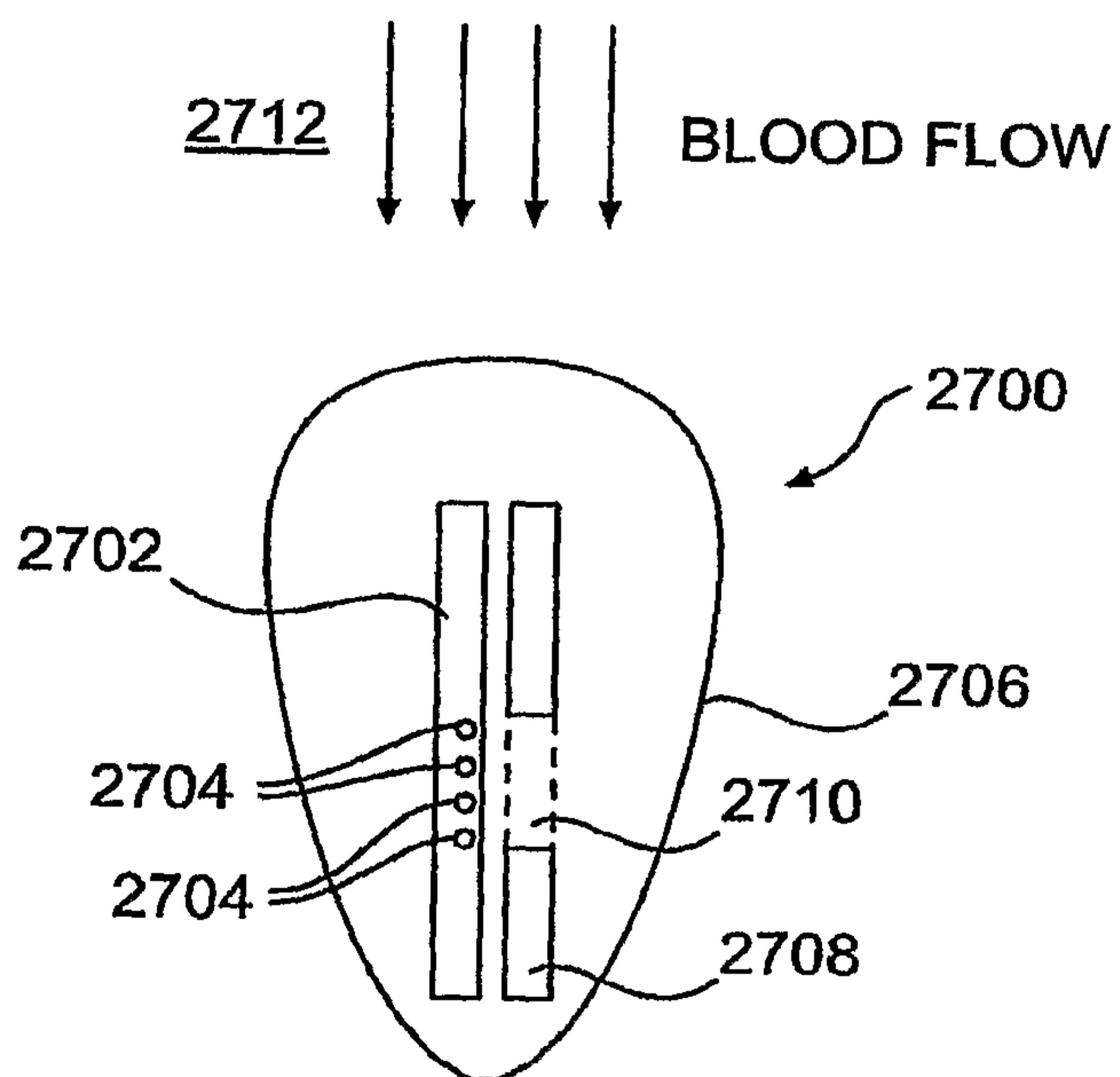

FIG. 27

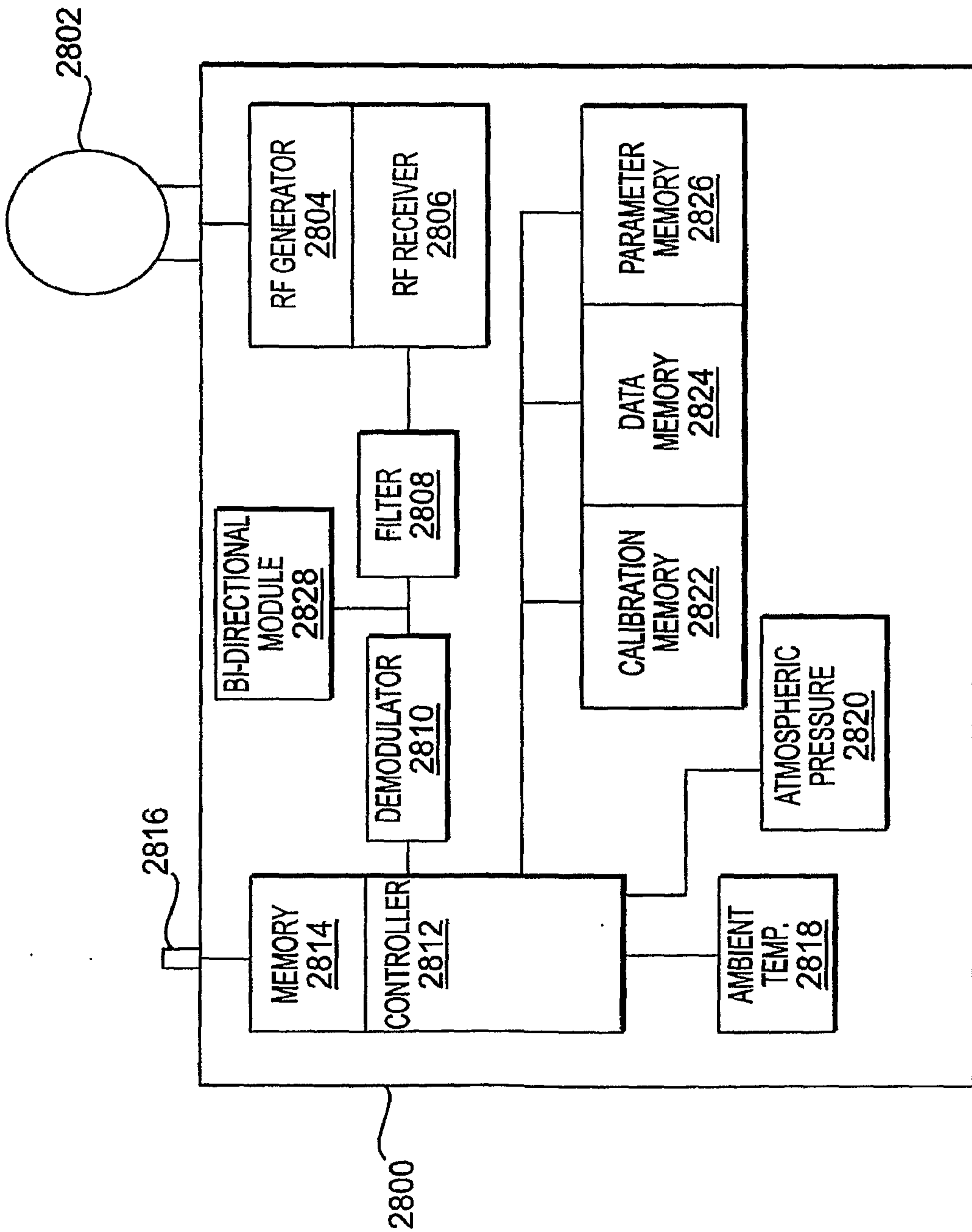

FIG. 28

