

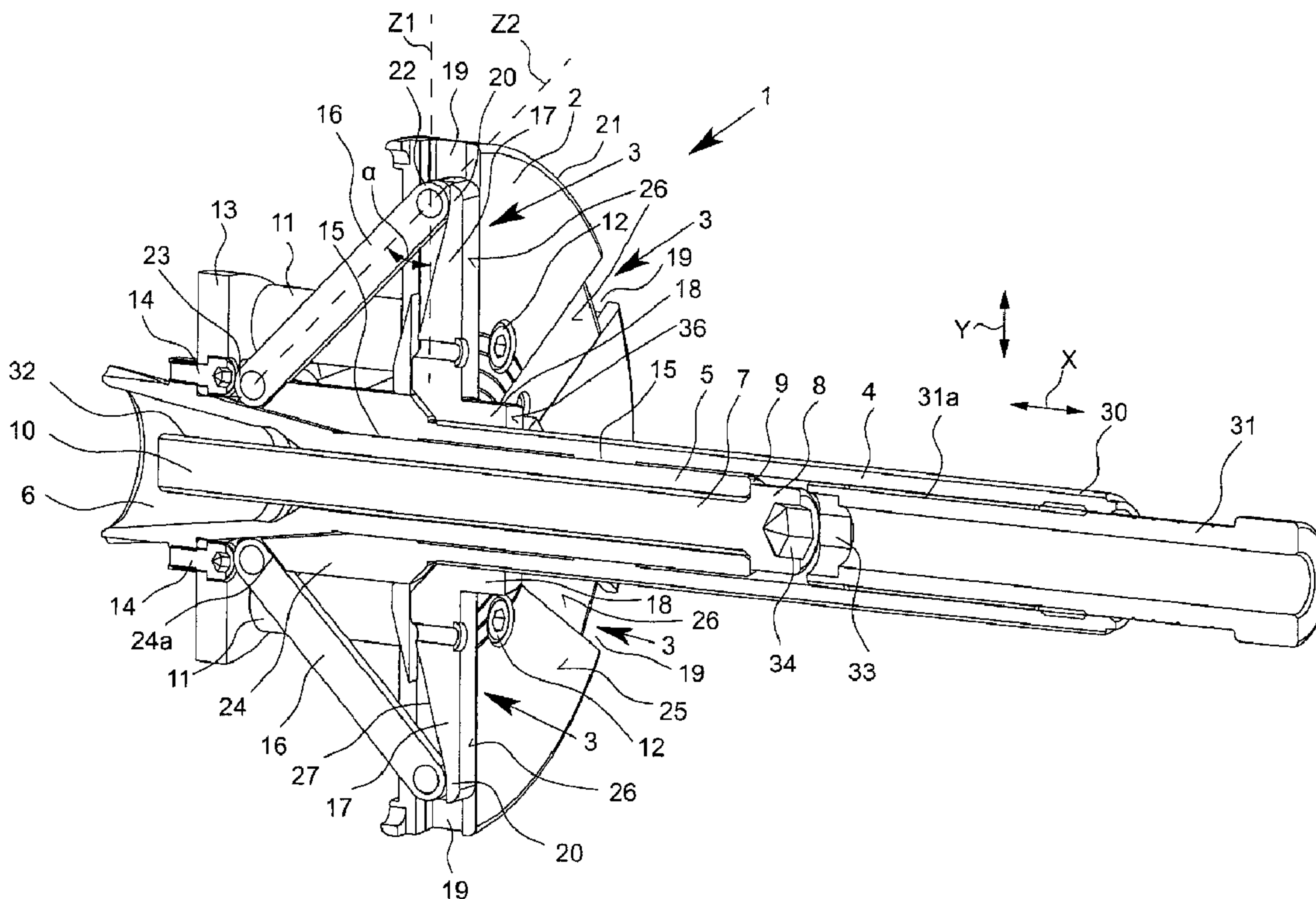

(86) **Date de dépôt PCT/PCT Filing Date:** 2013/08/01  
 (87) **Date publication PCT/PCT Publication Date:** 2014/03/13  
 (45) **Date de délivrance/Issue Date:** 2017/02/14  
 (85) **Entrée phase nationale/National Entry:** 2015/04/21  
 (86) **N° demande PCT/PCT Application No.:** EP 2013/002288  
 (87) **N° publication PCT/PCT Publication No.:** 2014/037074  
 (30) **Priorité/Priority:** 2012/09/10 (DE10 2012 017 789.5)

(51) **Cl.Int./Int.Cl. G01M 1/04** (2006.01)  
 (72) **Inventeurs/Inventors:**  
 WARKOTSCH, DIRK, DE;  
 JANZ, TILO, DE  
 (73) **Propriétaire/Owner:**  
 HAWEKA AG, DE  
 (74) **Agent:** GOWLING WLG (CANADA) LLP

(54) **Titre : DISPOSITIF DE SERRAGE A CENTRAGE**  
 (54) **Title: CLAMPING DEVICE HAVING HUB CENTRING**



(57) **Abrégé/Abstract:**

Illustrated and described is a clamping device (1) having hub centring for securing a vehicle wheel on the shaft of a balancing machine, having an abutment flange (2) with a plurality of centring elements (3), which are guided in a radially movable manner on

**(57) Abrégé(suite)/Abstract(continued):**

the abutment flange (2), for centring engagement in a centring hole in the rim, and having a clamping sleeve (4), which is guided in an axially movable manner with respect to the abutment flange (2), wherein the clamping sleeve (4) and the centring elements (3) are coupled together kinematically such that an axial movement of the clamping sleeve (4) results in a radial movement of the centring elements (3). According to the invention, provision is made for at least one clamping lever (16), which is connected in an articulated manner to the clamping sleeve (4) and a centring element (3), to be provided for the kinematic coupling of the clamping sleeve (4) and the centring element (3).