

L. K. STITTS & S. R. DRESSER.  
Sucker-Rod Elevator.

No. 133,390.

Patented Nov. 26, 1872.

*Fig. 1.*

*Fig. 2.*

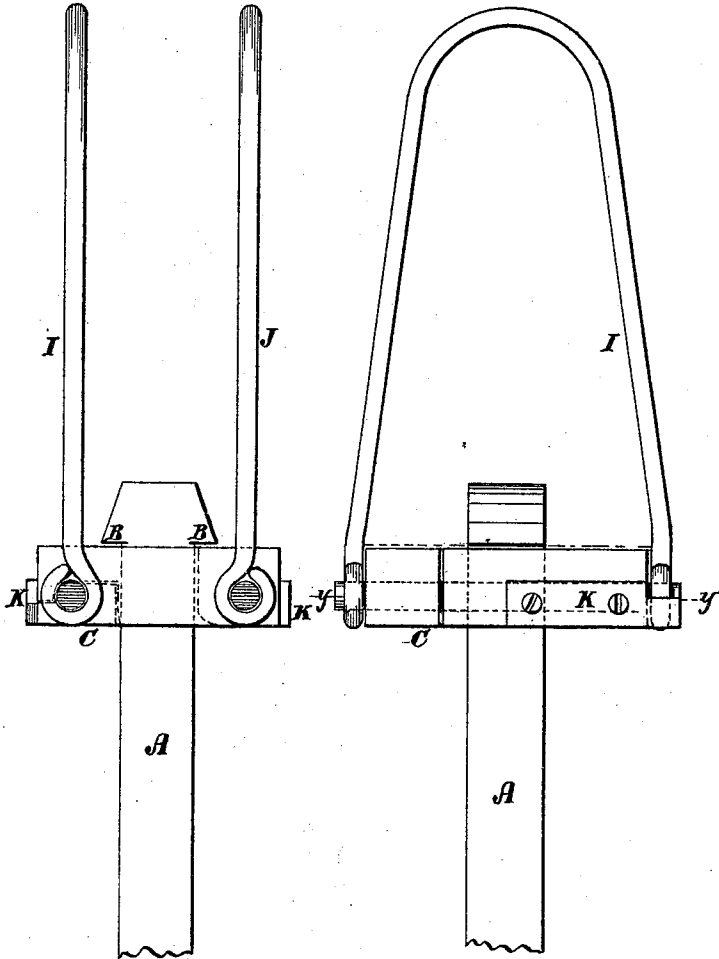

*Fig. 3.*

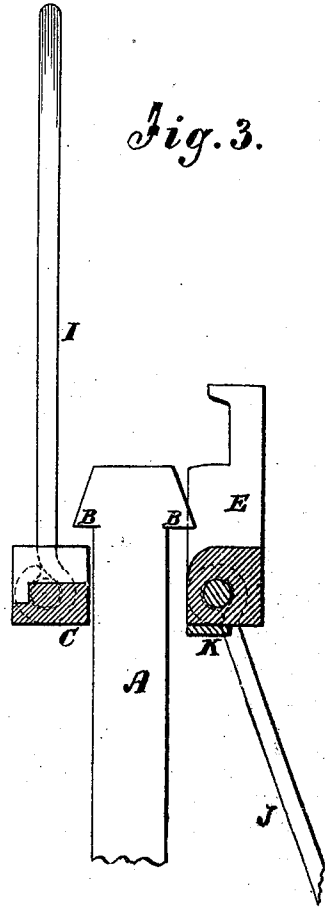

*Fig. 4.*

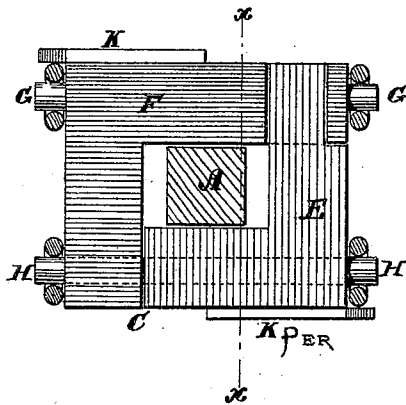

Witnesses:

*A. Bennekenhof.*  
*C. Sedgwick*

Inventor:

*L. K. Stitts*  
*S. R. Dresser*  
*Wm. M. Le*  
Attorneys.

# UNITED STATES PATENT OFFICE.

LEWIS K. STITTS AND SOLOMON R. DRESSER, OF PARKER'S LANDING, PA.

## IMPROVEMENT IN SUCKER-ROD ELEVATORS.

Specification forming part of Letters Patent No. 133,390, dated November 26, 1872.

*To all whom it may concern:*

Be it known that we, LEWIS K. STITTS and SOLOMON R. DRESSER, of Parker's Landing, in the county of Armstrong and State of Pennsylvania, have invented a new and useful Improvement in Sucker-Rod Elevator, of which the following is a specification:

This invention relates to the pumping machinery of oil and salt wells; and consists in a device for elevating the sucker or pump rod, the construction being as hereinafter described.

In the accompanying drawing, Figure 1 is a side view, showing the mode of attaching the bails and the sucker-rod as when confined. Fig. 2 is another view, showing one of the bails with the rod in another position. Fig. 3 is a section of Fig. 4 on the line *x x*, representing the elevator open. Fig. 4 is a horizontal section of Fig. 2 on the line *y y*.

Similar letters of reference indicate corresponding parts.

A is the sucker-rod, the upper end having a shoulder, B, on two sides, as seen in Fig. 1. C is the elevator, consisting of a box or frame made in two parts; one part, E, closes onto the other part, F, and opens as a gate to allow the sucker-rod to be slipped in and out. G G and H H are pivots or journals formed on the parts E F or passing through them, as seen in Fig. 4. I is a bail attached to the pivots G G. J is a bail, which is attached to the pivots H H. K is a stop-plate on the outside of each of the parts E F. The bail I is simply to serve

as a handle to the wrench. The bail J falls back onto the stop-plate K, which is fastened to the gate E of the elevator, so that when the weight of the sucker-rod is removed the weight of the bail will be sufficient to open the gate; hence it is easily removed from the sucker-rod.

In sending the elevator to the swivelman up in the derrick both bails are put onto a hook of the sucker-rod line, leaving the gate of the elevator open, so that the swivelman has nothing to do but to slip the elevator under the shoulders of the sucker-rod and shut the elevator-gate.

This device saves much valuable time and labor.

Having thus described our invention, we claim as new and desire to secure by Letters Patent—

1. The elevator C, bails I and J, and stop K, when the same are constructed and arranged to operate substantially as and for the purposes described.

2. The combination of the parts E and F, as and for the purposes described.

3. The stop-plate K, by means of which the gate E is opened, in combination with the bail J, substantially as described.

LEWIS K. STITTS.

SOLOMON R. DRESSER.

Witnesses:

GEO. W. COOK,

J. R. GOLDSBOROUGH.