

(No Model.)

S. R. DRESSER.  
OIL WELL PACKER.

No. 258,565.

Patented May 30, 1882.

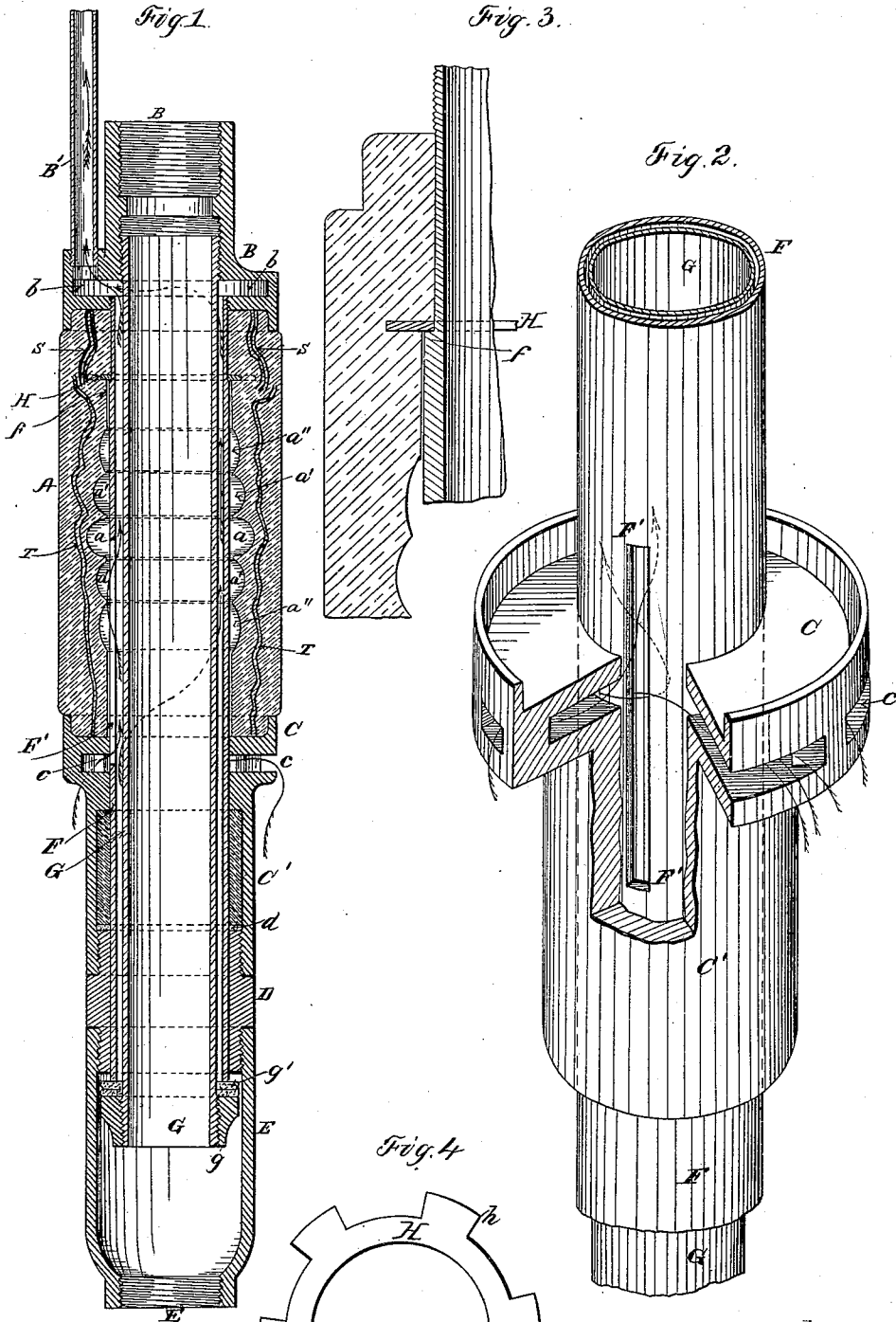

Witnesses  
W. R. Edden  
Robt H. Porter

Inventor  
S. R. Dresser  
Per *Walter T. Hall*  
Att's.

# UNITED STATES PATENT OFFICE.

SOLOMON R. DRESSER, OF BRADFORD, PENNSYLVANIA.

## OIL-WELL PACKER.

SPECIFICATION forming part of Letters Patent No. 258,565, dated May 30, 1882.

Application filed January 9, 1882. (No model.)

To all whom it may concern:

Be it known that I, SOLOMON R. DRESSER, a citizen of the United States; and a resident of Bradford, in the county of McKean, in the State of Pennsylvania, have invented new and useful Improvements in Oil-Well Packers; and I do hereby declare that the following is a full, clear, and exact description thereof, reference being had to the accompanying drawings, and the letters or figures of reference marked thereon.

The object of an oil-well packer is twofold: first, to prevent the water which enters the well from the crevices in the upper rock-strata from mingling with the oil which enters the well from the lower or oil-bearing strata of rock; second, to confine the gas which enters the well from the lower rocks and utilize its force or pressure to expel the oil from the well through the eduction-tube, or, in other words, to cause the well to flow.

When the gas is so much exhausted as not to have pressure sufficient to expel the oil a pump is put into the eduction-tube and the oil is pumped out. When this occurs there is no object served by confining the gas below the packer; but it is still necessary to keep the well packed to shut off the water, and it is desirable to draw off the gas in a separate tube for the purpose of burning the same as a fuel under the steam-boiler, which generates steam for the engine which operates the pump. Hence it is desirable to so construct the packing apparatus as to permit of drawing off the gas when desired without interfering with the packing of the well. Devices for this purpose have been heretofore made; and my present invention consists, first, in improved means for conveying the gas past the packer; second, in improvements in the construction of the rubber annulus; third, in various minor details of construction.

My device is shown in the accompanying drawings as follows: Figure 1 is a longitudinal vertical section of my packing device. Fig. 2 is a detail of construction showing the lower flange and the two pipes F and G. Fig. 3 is a view showing details. Fig. 4 is a view of the shoulder-lining ring H.

The letters of reference indicate parts as follows:

A is the rubber annulus. B is the upper

compressing-flange. *b* is a chamber in the same. *B'* is a tube leading from said chamber. BB is where the upper eduction-tube attaches to the flange B. C is the lower compressing-flange. *c* is a chamber therein. *C'* is a downward extension from flange C. D is coupler. E is a reducer. EE is the point where the lower eduction-tube attaches to the reducer E. F and G are two tubes which extend from the upper flange, B, down through the lower flange, C, its extension *C'* and the coupler D, and end in the reducer E. *g* is a shoulder on the end of the tube G. *g'* is a packing-washer on the shoulder *g* and between it and the pipe F. H is a shoulder-lining ring within the annulus A, and has radial dovetailed extensions *h*. *a a' a' a' a'* are indentations of varying depth in the annulus on its inner surface. *F'* is a slot in the pipe F.

The principle on which my present packer operates to pack the well is precisely similar to that which is shown in my patent of May 11, 1880, No. 227,419, and also several other patented packers, not necessary to mention.

The annulus A, flanges B and C, and the tubes G and E, forming a slip-joint, are old and common elements in a packer.

In my present device the flanges B and C are made with contained chambers; that in B communicates with a tube, *B'*, which leads to the top of the well, while the one in C opens out freely into the well-space. The tube F, which contains the tube G, extends from the chamber *b* in flange B down below the chamber in the flange C, and a slot, *F'*, in said tube F affords communication from said chamber *c* to chamber *b*. Therefore, when the annulus A is expanded in the usual manner, so as to pack the well, there is a passage for gas, as shown by arrows in the drawings. The leather or rubber washers *g'*, between the lower end of tube F and the shoulder *g* on tube G, prevent oil from entering this passage from the lower eduction-tube, and the washer *d* forms a stuffing-box around the tube F and prevents the passage of oil up on the outside of tube F. Both the tubes F and G are attached to and move with the upper flange and slide loosely within the lower flange.

The tube F is provided with a shoulder, *f*, and the rubber A is provided with a shoulder lined with a metal ring, H, and when the tube

F is screwed into the flange B the shoulder *f* comes in contact with the shoulder-ring H and firmly holds the rubber in place within the flange B. The shoulder *g* holds the lower flange, C, in place upon the rubber at its lower end by coming in contact with the shoulder formed by the lower end of the coupler D. The ring H is embedded into the rubber before it is vulcanized, and, having dovetailed radial lugs *h* extending therefrom, as shown in Fig. 4, it is very firmly held in place. The rubber annulus is made properly flexible by being provided on its inner side with a series of corrugations which vary in depth as follows:

15 *a*, which is in the center, is quite deep; *a' a'*, which are just above and below *a*, are of less depth; and *a'' a''*, which are just above and below *a' a'*, are still less in depth. This construction insures a perfectly regular bulge to the rubber when the annulus is under pressure.

I am aware that in the patent to Fowler and Morgan, Reissue No. 8,491, the rubber annulus is made thinner in the center; and I am also aware that packing-rubbers have been made more flexible by being corrugated; but I believe that a series of corrugations on the inside and at the middle of the annulus, and of varying depth, as shown, has not heretofore been used.

I am also aware that in the patent to L. W. Hoadley, No. 203,044, a passage for gas is made between the rubber annulus and the eduction-tube, but the invention is not there shown as adapted to that class of packers wherein the rubber annulus is compressed by the weight of the upper tubing. However, whatever is there shown which is common with the device shown by me I hereby disclaim as forming any part of my invention.

The rubber forming the packer sometimes cracks after usage, and it in time becomes rotten, to a greater or less degree, in places, and when under strain is liable to crack or tear. To avoid the separation of the rubber at such times, and also to give it a more desirable flexibility, I insert in the rubber while soft—that is, when building it up in the mold—pieces of canvas-duck S T. The rubber is subject to the most strain when being drawn from the well, and this strain comes at points outside of and above the ring H; so I place at that point the strip of duck S. The wide strip or

band of duck T is placed, as shown, to receive the strain when the packer is under pressure, namely, along the body at the point where the packer bulges out when under pressure.

What I claim as new is—

1. In an oil-well packer wherein is a rubber annulus arranged between two compressing-flanges which are attached to sections of tubing which telescope together, the combination therewith of chambers within said flanges, and a slotted tube connected with one of said flanges and communicating between said chambers, substantially as and for the purposes mentioned.

2. The combination within an oil-well packer of the following elements: a rubber annulus arranged between two chambered flanges, a tube within said annulus communicating between said chambers and containing a tube which forms part of the eduction-tube, and which is sufficiently smaller to form an annular space between said tubes, which space is closed at its lower end by packing upon a shoulder on the inner tube, substantially as and for the purposes set forth.

3. In an oil-well packer, the combination of the following elements: the rubber annulus A, flanges B and C, with chambers *b* and *c*, tube F, with slot F', tube G, with shoulder *g* and packing *g'*, extension C' of flange C, coupler D, packing *d*, and reducer E, substantially as shown.

4. In combination with the rubber annulus of an oil-well packer, a shoulder-lining ring, H, having radial dovetail lugs *h*, which ring is embedded in the rubber annulus at the time of its formation.

5. In an oil-well packer, a rubber annulus provided with a series of indentations of different depth, arranged in the order shown upon the inner wall of said annulus, for the purposes mentioned.

6. In the rubber annulus of an oil-well packer, the shoulder-lining ring H and a strip of duck cloth or other fabric within the material back of said ring, substantially as and for the purposes mentioned.

In testimony that I claim the foregoing I have hereunto set my hand.

SOLOMON R. DRESSER.

Witnesses:

JNO. K. HALLOCK,  
E. A. SMITH.