

Sept. 25, 1962

G. KRIKORIAN

3,055,251

SPRING TENSIONED CUTTING WIRE DEVICE

Filed March 20, 1961

2 Sheets-Sheet 1

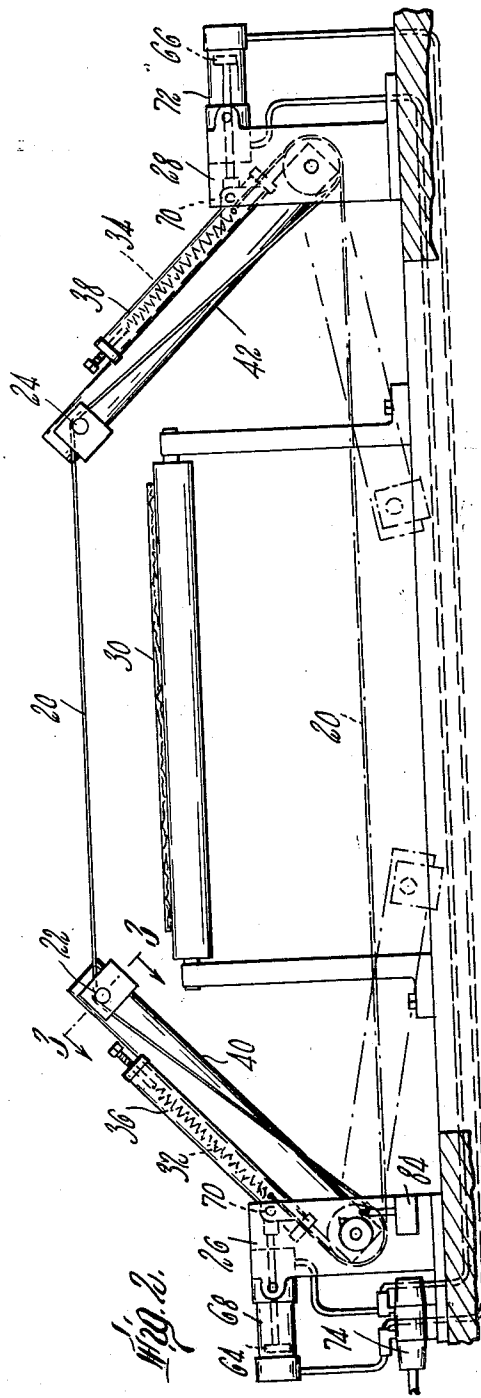
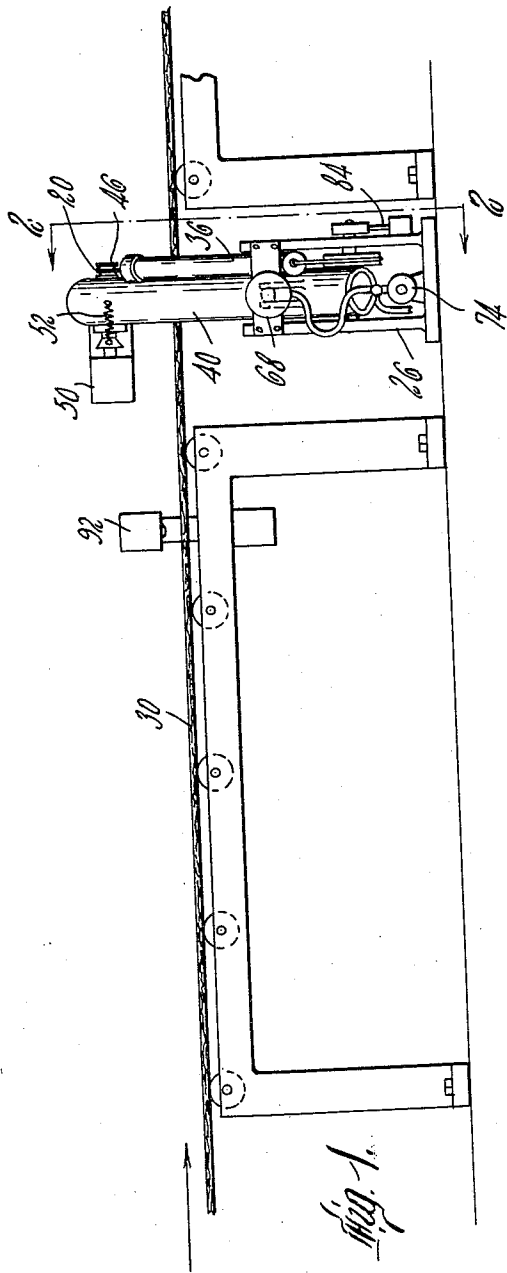

Sept. 25, 1962

G. KRİKORIAN

3,055,251

SPRING TENSIONED CUTTING WIRE DEVICE

Filed March 20, 1961

2 Sheets-Sheet 2

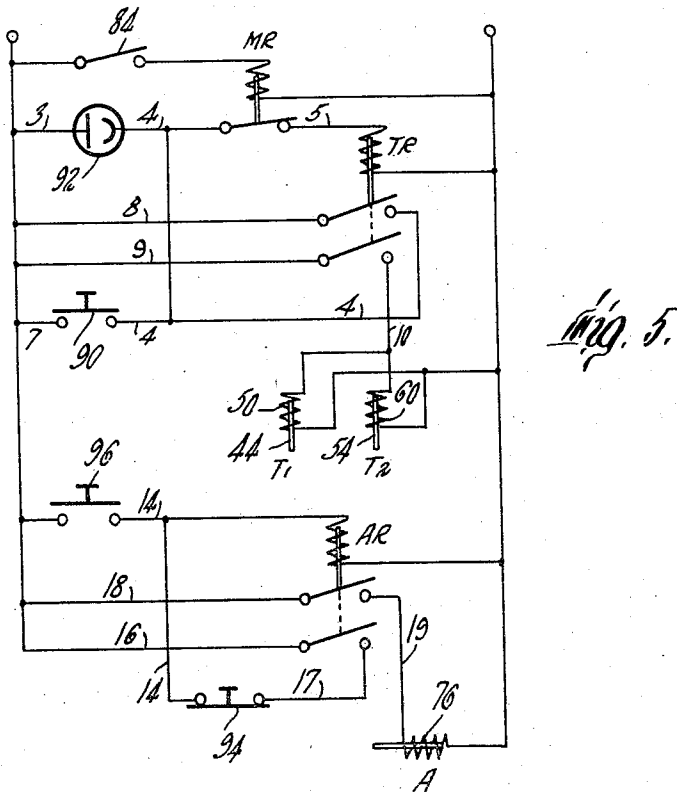
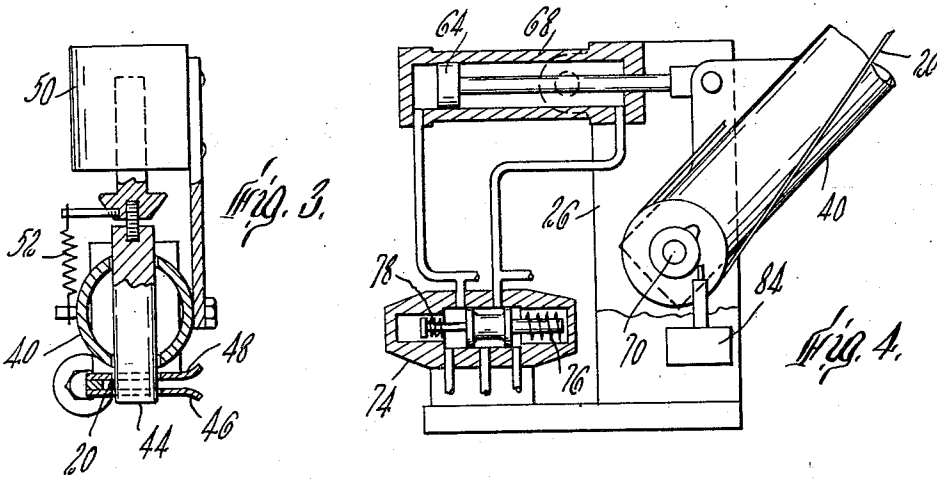

1

3,055,251

SPRING TENSIONED CUTTING WIRE DEVICE  
Garo Krikorian, Worcester, Mass., assignor to Rice  
Barton Corporation, Worcester, Mass., a coporation of  
Massachusetts

Filed Mar. 20, 1961, Ser. No. 97,062  
2 Claims. (Cl. 83—587)

The present invention relates to an improved device for severing a traveling web, and is well adapted for use in a machine for the manufacture and processing of continuous webs, such as paper, for severing the web in the event of an accidental break or other mishap in the operation of the machine.

It is an object of the invention to provide a simple and efficient device for severing a rapidly moving web of paper or other material which will operate at a high rate of speed in response to an electronic or other signal to effect a clean break of the web at the desired point in the process.

In the preferred construction shown the severing of the rapidly moving web is accomplished in a most efficient manner by passing a tensed cutting wire across the web. The cutting wire, stretched between two guides, is maintained at all times under a substantial tension. For fast cutting action with a minimum of effort the wire is held by a trip device in an offset position such that when the trip device is operated to release the wire it will snap across the path of the traveling web to the straight line position between said guides. In the embodiment of the invention shown the trip device comprises one, or a pair of pivoted trip arms each having an axially shiftable pin support for the tensed wire. The arms are moved to cause the pins to engage and raise the wire to the offset ready position preparatory for release when an appropriate signal to cut is given. The two ends of the cutting wire are attached to powerful coiled springs which are suitably mounted as integral units with the trip arms above referred to. An electrical control circuit provides a suitable means for effecting automatic operation of the web cutting device.

The several features of the invention will be readily appreciated by one skilled in the art from the following description taken in connection with the accompanying drawings in which:

FIG. 1 is a somewhat diagrammatic view in side elevation of a traveling web and a web severing device incorporating therein the several features of the invention;

FIG. 2 is a view looking from the right of the web severing device shown in FIG. 1;

FIG. 3 is a partial section taken on a line 3—3 of FIG. 2 illustrating one of the trip pins;

FIG. 4 is a fragmentary view partly in section showing the mechanism for resetting the trip mechanism; and

FIG. 5 is a diagram of the electrical operating devices for the web severing device.

As shown, the web severing device of the present invention is applied to a paper manufacturing process which may be of any ordinary description in which the paper web traveling at a substantial rate is passed through various equipment such as coating baths, dryers, dryer hoods and the like. In the event of an accidental break of said web, it is important to cut the web at a predetermined point at which further increments of the web can be shunted into waste bins and thus avoid the choking up of the equipment referred to with surplus paper stock.

The web severing device shown comprises a web severing wire which is supported in such a manner as to make a web severing pass through the web when tripped into operation.

The web severing wire is shown at 20 supported on two guide rollers 22, 24 one being mounted on a bracket 26 and the other on a bracket 28 at opposite sides of the

2

traveling web designated at 30. The respective ends of said wire are attached to two coiled take-up springs 32, 34 mounted within take-up cylinders 36, 38 which are carried on arms 40 and 42 having pivotal supporting axes which coincide with those of the guide rollers 22, 24. The springs 32, 34 tense the wire 20 which thus tends to be held in a taut straight line position between the guide rollers 22, 24, said line extending across and substantially above the plane of the traveling web.

The arms 40, 42 constitute a trip device by means of which that portion of the tensed wire 20 extending between the guide rollers 22, 24 is supported in an extended or offset position with relation to said guide rollers above and encompassing the web 30.

The arm 40 has mounted on the free end thereof a laterally extending pin 44 which is shiftable axially between a wire engaging position as shown in FIG. 3 and a retracted position in which the wire 20 is allowed to fall against the web 30. The wire is guided in a predetermined path with relation to the pin 44 between two flange type guides 46, 48. The pin 44 is automatically shifted from one to the other position by means of a solenoid 50, which acts when energized to retract the pin 44 to its inoperative position. When the solenoid is deenergized a return spring 52 returns the pin 44 to its extended wire engaging position.

The arm 42 has mounted on the free end thereof a pin 54 which is mounted, and is operated, in a manner identical to the operation of pin 44. The pin 54 projects through an aperture formed between two flange guides and is retracted by a solenoid against the pressure of a return spring. These parts being identical with similar parts for operating pin 40 are not shown.

The arms 40 and 42 are moved between a low inoperative position shown in dot-and-dash lines in FIG. 2 in which the trip pins 44 and 54 are located below the level of the wire when stretched directly from one to the other of the guide rollers 22 and 24, and an alternative raised position in which the trip pins have engaged and have raised the intervening portion of the tensed wire to the off-set position in which the wire encompasses the web traveling along a predetermined path. These movements of the arms 40, 42 are effected by means of two fluid actuated pistons 64, and 66. The piston 64 is carried on a hydraulic cylinder 68 attached to the supporting bracket 26 for the arm 40, and is pivotally connected at 70 to the arm 40. The piston 66 is similarly mounted in a hydraulic cylinder 72 attached to the supporting bracket 28 and is pivotally connected to the arm 42.

The two cylinders 68, 72 are operated by means of a four-way hydraulic valve 74 which is adapted to be shifted between alternative operating positions by means of a solenoid 76 operating against a spring 78.

Electrically operating connections are provided for operating the web severing device as illustrated in the electrical diagram FIG. 5. As shown in this FIGURE the two solenoids 50 and 60 are arranged to be operated by means of a relay TR which acts when energized to close a holding circuit and at the same time to close a circuit through the two solenoids 50 and 60 by means of which pins 44, 54 are withdrawn to release the tensed wire 20. The up and down movement of the arms 40, 42 is controlled by means of the solenoid 76 which is in turn operated by means of a relay switch AR having holding circuit contacts 16—17 and solenoid energizing contacts 18—19. There is also provided a microswitch 84 which operates a relay MR to open the TR contacts 4—5 to deenergize the trip solenoid relay TR. The microswitch is located to be engaged, and to be rendered operative by movement of one of the arms 40 to the fully retracted inoperative position shown in

dotted lines in FIG. 2. The operation of the web severing device will be briefly described in connection with the drawings and more particularly the electrical diagram of FIG. 5 as follows:

It is assumed that the web severing device is in the operative position shown in full lines in the several figures of the drawings, in which the arms 40, 42 are raised. The trip pins 44, 45 carried by said arms are maintained by spring means in a forwardly projecting position in which the tensed web severing wire 20 is supported in the offset raised fully extended web encompassing position. It is further assumed that the device may be tripped into operation to sever the web by operation either by means of the manual switch designated at 90 in the electrical diagram FIG. 5, or alternatively by means of a signal transmitted by an electrically signaling device, for example, the photo-electric cell 92 also diagrammatically shown in FIG. 5.

In the event that the photo-electric cell 92 is now rendered operative as, for example, by a break in the traveling web, contacts 3—4 close energizing TR. TR contacts 9—10 close energizing the trip solenoids 50, 60, designated also at  $T_1$ ,  $T_2$  in the electrical diagram. The energizing of the trip solenoids 50, 60 causes pins 44, 54 to be withdrawn releasing the tensed wire 20 which moves very rapidly downwardly to a straightened position between the guide rollers 22, 24. Since the holding circuit contacts 8—4 are closed, relay TR, and solenoids  $T_1$ ,  $T_2$  remain energized.

In order to reset the machine in operating condition the operator now presses manual down switch 94 thus opening contacts 17—14 to deenergize relay AR which in turn causes AR contacts to be deenergized. AR relay holding circuit contacts 16—17 open. AR contacts 18—19 open deenergizing the solenoid 74, further designated in the electrical diagram FIG. 5 at A. The release of solenoid 76 designated in the electrical diagram at A operates to reverse the position of the four-way valve which shifts, opening the hydraulic cylinders 68, 72 to exhaust.

The arms 40, 42 move downwardly to the dotted line position shown in FIG. 2. In this position the arm 40 engages and closes microswitch 84 thus energizing relay MR. MR contact 4—5 opens deenergizing relay TR. TR holding contact 8—4 drops out. TR contact 9—10 drops out deenergizing the trip solenoids 50, 60, further designated in FIG. 5 at  $T_1$ ,  $T_2$ , so that the trip pins 44, 54 are permitted to return to their advanced operating position under the influence of their respective springs 52, 62. The operator now presses manual switch 96 closing switch contacts 13—14 to energize relay AR. AR holding contacts 16—17 close. AR contacts 18—19 close energizing the solenoid 74 which in turn acts through the four-way valve 74 to supply fluid to the cylinders 68, 72 so that the arms 40, 42 will shift to the raised full line position of FIG. 2.

carrying with them the tensed wire 20 which is thus returned to its offset raised position encompassing the path of movement of the web 30.

The invention having been described what is claimed is:

1. A web severing device for use in a machine for the manufacture and processing of continuous webs, such as paper, having in combination, a cutting wire adapted to be drawn across the web in a cutting movement, a pair of guides spaced from one another around which said wire is passed, means for tensing that portion of said wire extending between said guides, a trip device for supporting said tensed portion of the wire in a position off-set from between said two guides and encompassing the web, said trip device comprising a pair of pivoted arms, a trip element supported on said arm for movement between wire engaging and withdrawn positions, means for moving the arms and trip elements thereon to engage with and draw said tensing wire to the off-set position, and means for moving said trip elements relative to said arms to release the tensed wire and thereby to effect a severing movement of the wire through the web.

2. A web severing device for use in a machine for the manufacture and processing of continuous webs, such as paper, having in combination with a stationary support, a cutting wire adapted to be drawn across the web in a cutting movement, supporting means for said wire including, a pair of guides mounted on said support, spaced from one another around which said wire passes, a pair of arms pivotally mounted on said support, a pair of coaxially shiftable trip pins on said arms adapted to engage a portion of said wire extending between said guide rollers, means for tensing that portion of said wire extending between said guides, means including a solenoid, operable for moving said arms and trip pins thereon to engage with and draw said tensed wire to an offset position relative to said guide rollers and encompassing said web, a trip device including an actuator and solenoids controlled thereby for moving said trip pins to release said tensed wire and thereby to effect a severing movement of the wire through the web, and electrical means including said solenoids acting when rendered operative to move said arms downwardly beneath the straightened wire, to return said pins to the pin engaging position, and to shift said arms and pins engaging said wire to said offset ready position.

#### References Cited in the file of this patent

##### UNITED STATES PATENTS

2,609,047 Wilkoff ----- Sept. 2, 1952

##### FOREIGN PATENTS

663,187 France ----- Mar. 30, 1929  
1,147,300 France ----- June 3, 1957