



(43) International Publication Date
25 September 2014 (25.09.2014)

- (51) International Patent Classification:
C10G 65/02 (2006.01) C10L 1/14 (2006.01)
- (21) International Application Number:
PCT/US2014/015907
- (22) International Filing Date:
12 February 2014 (12.02.2014)
- (25) Filing Language: English
- (26) Publication Language: English
- (30) Priority Data:
61/794,859 15 March 2013 (15.03.2013) US
- (71) Applicant: LUMMUS TECHNOLOGY INC. [US/US];
1515 Broad Street, Bloomfield, NJ 07003-3096 (US).
- (72) Inventors: ARORA, Arun; 1515 Broad Street, Bloomfield, NJ 07003-3096 (US). MUKHERJEE, Ujjal, K.; 6 Grove Terrace, Montclair, NJ 07042 (US). LOUIE, Wai Seung; 1515 Broad Street, Bloomfield, NJ 07003-3096 (US). GREENE, Marvin, I.; 2310 Wickham Terrace, Clifton, NJ 07013 (US).
- (74) Agents: GRIFFITH, Aron, T. et al.; Osha . Liang LLP, 909 Fannin Street, Suite 3500, Houston, TX 77010 (US).
- (81) Designated States (unless otherwise indicated, for every kind of national protection available): AE, AG, AL, AM,

AO, AT, AU, AZ, BA, BB, BG, BH, BN, BR, BW, BY, BZ, CA, CH, CL, CN, CO, CR, CU, CZ, DE, DK, DM, DO, DZ, EC, EE, EG, ES, FI, GB, GD, GE, GH, GM, GT, HN, HR, HU, ID, IL, IN, IR, IS, JP, KE, KG, KN, KP, KR, KZ, LA, LC, LK, LR, LS, LT, LU, LY, MA, MD, ME, MG, MK, MN, MW, MX, MY, MZ, NA, NG, NI, NO, NZ, OM, PA, PE, PG, PH, PL, PT, QA, RO, RS, RU, RW, SA, SC, SD, SE, SG, SK, SL, SM, ST, SV, SY, TH, TJ, TM, TN, TR, TT, TZ, UA, UG, US, UZ, VC, VN, ZA, ZM, ZW.

(84) Designated States (unless otherwise indicated, for every kind of regional protection available): ARIPO (BW, GH, GM, KE, LR, LS, MW, MZ, NA, RW, SD, SL, SZ, TZ, UG, ZM, ZW), Eurasian (AM, AZ, BY, KG, KZ, RU, TJ, TM), European (AL, AT, BE, BG, CH, CY, CZ, DE, DK, EE, ES, FI, FR, GB, GR, HR, HU, IE, IS, IT, LT, LU, LV, MC, MK, MT, NL, NO, PL, PT, QA, RO, RS, SE, SI, SK, SM, TR), OAPI (BF, BJ, CF, CG, CL, CM, GA, GN, GQ, GW, KM, ML, MR, NE, SN, TD, TG).

Declarations under Rule 4.17:

— as to applicant's entitlement to apply for and be granted a patent (Rule 4.17(ii))

Published:

— with international search report (Art. 21(3))

(54) Title: HYDROPROCESSING THERMALLY CRACKED PRODUCTS

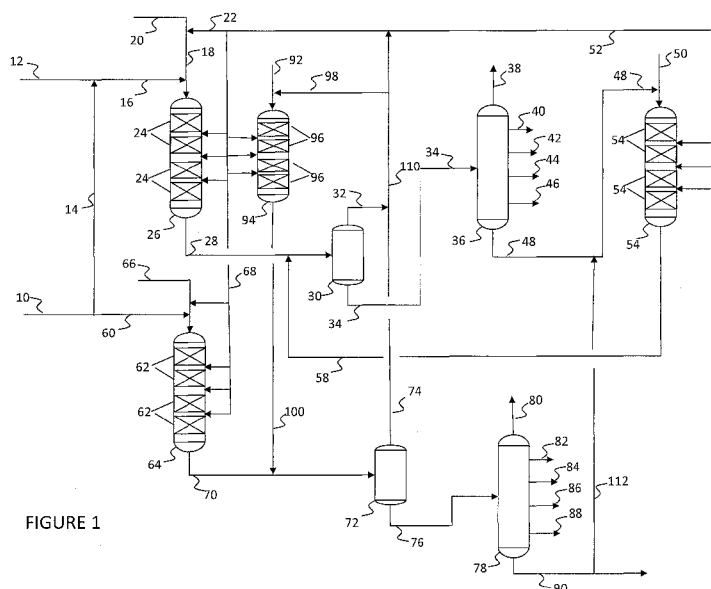

FIGURE 1

(57) Abstract: Embodiments herein relate to a process flow scheme for the processing of gas oils and especially reactive gas oils produced by thermal cracking of residua using a split flow concept. The split flow concepts disclosed allow optimization of the hydrocracking reactor severities and thereby take advantage of the different reactivities of thermally cracked gas oils versus those of virgin gas oils. This results in a lower cost facility for producing base oils as well as diesel, kerosene and gasoline fuels while achieving high conversions and high catalyst lives.

WO 2014/149247 A1

HYDROPROCESSING THERMALLY CRACKED PRODUCTS

FIELD OF THE DISCLOSURE

[0001] Embodiments disclosed herein relate generally to processing of gas oils and especially reactive gas oils produced by thermal cracking of residua using a split flow concept.

BACKGROUND

[0002] Hydrocrackers have always produced environmentally friendly products, even before environmental regulations on products increased. No other process can take low value, highly aromatic, high sulfur, and high nitrogen feedstocks and produce a full slate of desirable sweet products: LPG, high quality diesel fuel, hydrogen-rich FCC feed, ethylene cracker feed, and/or premium lube unit feedstocks.

[0003] Modern hydrocracking was commercialized in the early 1960's. These early units converted light feedstocks (from atmospheric crude towers) into high-value, high-demand gasoline products. In addition, high hydrocracker volume gain (exceeding 20%) added significantly to the refinery bottom line. Because of these strong attributes, hydrocracker capacity has increased steadily over the years.

[0004] Increased environmental regulations on gasoline and diesel have made hydrocracking the most essential process resulting in ever greater increases in worldwide capacity. The most recent grassroots hydrocrackers were designed to maximize the production of middle distillates from increasingly difficult feedstocks such as FCC LCO, Heavy Vacuum Gasoils, and Heavy Coker Gas Oils. Like their predecessors, most modern hydrocrackers produce high-value, environmentally friendly distillate products including massive volumes of ultra-low sulfur diesel (ULSD), even with progressively more demanding feedstocks. Early generation hydrocrackers were in the 10,000 barrel-per-day range while many new units today exceed 100,000 barrels per day.

[0005] Growing demand for middle distillates, declining market for high sulfur fuel oil, and increasingly stringent environmental regulations are putting refineries, especially those with lower Nelson Complexity Index, under immense margin pressures and even forcing many to shut down. This recent trend has led to grassroots projects for distillate-oriented conversion technologies. Very few, if any, refineries

have their conversion strategy focused on FCC technology, and many FCC units are operating in low severity distillate mode or are occasionally being converted to a propylene producer. Hydrocracking offers greater flexibility to process opportunity crudes while producing premium grade clean fuels which improves refinery margins.

[0006] Some refineries have tried to solve the difficulties in dealing with heavy feedstocks by building two separate hydrocracker, one for lube and one for fuels. Another solution investigated was to just hydrotreat the thermally cracked gas oil and then feed the hydrotreated gas oil to FCC and install a high conversion hydrocracker and take a large bleed of UCO to lube base oil production. Others have proposed to solvent deasphalt the residuum feed and process only the deasphalted oil in a Resid Hydrocracking Unit (RHU), e.g., ebullated-bed hydrocracking. Also, others have processed the unconverted vacuum resid from a Resid Hydrocracking Unit in an SDA Unit and recycled the DAO back to the front end of the RHU or further treating the DAO in a residue fixed-bed hydrotreatment unit to produce low sulfur fuel oil or feed to a FCC unit.

SUMMARY OF THE DISCLOSURE

[0007] In one aspect, embodiments disclosed herein relate to a process for upgrading gas oils to distillate hydrocarbons. The process may include: dividing a first gas oil stream into a first and second portions; mixing a second gas oil stream and the first portion of the first gas oil stream to form a mixed gas oil stream; contacting the mixed gas oil stream and hydrogen with a first hydroconversion catalyst in a first hydrocracker reaction system to convert at least a portion of the hydrocarbons in the mixed gas oil stream to distillate hydrocarbons; recovering an effluent from the first hydrocracker reaction system comprising unconverted hydrocarbons and the distillate hydrocarbons; fractionating the effluent from the first hydrocracker reaction system into one or more hydrocarbon fractions including a fraction comprising the unconverted hydrocarbons; contacting hydrogen and the fraction comprising the unconverted hydrocarbons with a second hydroconversion catalyst in a second hydrocracker reaction system to convert at least a portion of the hydrocarbons in the mixed gas oil stream to distillate hydrocarbons; feeding the effluent from the second hydrocracking reaction system to the fractionating step for concurrent fractionation with the effluent from the first hydrocracker reaction system; contacting hydrogen and the second portion of the first gas oil stream with a third hydroconversion catalyst in a

third hydrocracker reaction system to convert at least a portion of the hydrocarbons in the second portion to distillate hydrocarbons; fractionating an effluent from the third hydrocracker reaction system to recover two or more hydrocarbon fractions.

[0008] In another aspect, embodiments disclosed herein relate to a system for upgrading gas oils to distillate hydrocarbons. The system may include: a flow control system for dividing a first gas oil stream into a first and second portions; a mixing device for mixing a second gas oil stream and the first portion of the first gas oil stream to form a mixed gas oil stream; a first hydrocracker reaction system for contacting the mixed gas oil stream and hydrogen with a first hydroconversion catalyst to convert at least a portion of the hydrocarbons in the mixed gas oil stream to distillate hydrocarbons; a separation system for fractionating an effluent from the first hydrocracker reaction system into one or more hydrocarbon fractions including a fraction comprising the unconverted hydrocarbons; a second hydrocracker reaction system for contacting hydrogen and the fraction comprising the unconverted hydrocarbons with a second hydroconversion catalyst to convert at least a portion of the hydrocarbons in the mixed gas oil stream to distillate hydrocarbons; a flow line for feeding the effluent from the second hydrocracking reaction system to the fractionating system for concurrent fractionation with the effluent from the first hydrocracker reaction system; a third hydrocracker reaction system for contacting hydrogen and the second portion of the first gas oil stream with a third hydroconversion catalyst to convert at least a portion of the hydrocarbons in the second portion to distillate hydrocarbons; and a separation system for fractionating an effluent from the third hydrocracker reaction system to recover two or more hydrocarbon fractions.

[0009] Other aspects and advantages will be apparent from the following description and the appended claims.

BRIEF DESCRIPTION OF DRAWINGS

[0010] Figure 1 is a simplified process flow diagram of a process for hydroprocessing gas oils according to embodiments herein.

DETAILED DESCRIPTION

- [0011] In one aspect, embodiments disclosed herein relate to processing of gas oils and especially reactive gas oils produced by thermal cracking of residua using a split flow concept.
- [0012] As used herein, “conversion” refers to the hydrocracking of hydrocarbon materials boiling above about 650F to hydrocarbon materials boiling below about 650F, both temperatures as defined by ASTM D 1160 or equivalent distillation method.
- [0013] As used herein, “reaction severity” refers to the catalyst average temperature in degrees Fahrenheit of the catalysts loaded in the hydrocracking reactors of a hydrocracking reactor system multiplied by the average hydrogen partial pressure of said hydrocracking reactors in Bar absolute and divided by the liquid hourly space velocity in said hydrocracking reactors.
- [0014] As used herein, “first gas oil stream” refers to gas oils derived or recovered from one or more of petroleum crudes, shale oils, tar sands bitumen, coal-derived oils, tall oils, black oils, and bio-oils and having an atmospheric equivalent, initial boiling point of about 650-680F based on ASTM method D1160 or equivalent.
- [0015] As used herein, “second gas oil stream” refers to gas oils produced from thermal or catalytic cracking of heavy oils and having an initial boiling point of about 650-680F based on ASTM method D1160 or equivalent. In some embodiments, the second gas oil stream includes gas oils produced by at least one of delayed coking, fluid coking, visbreaking, steam cracking, and fluid catalytic cracking.
- [0016] Processes for upgrading gas oils to distillate hydrocarbons according to embodiments herein may include dividing the first gas oil stream into a first and second portions. The second gas oil stream may be mixed with the first portion of the first gas oil stream to form a mixed gas oil stream or a blended gas oil stream.
- [0017] The first and second gas oil streams may be mixed at a specified split gas oil ratio (defined herein as the weight ratio of second gas oil stream to that of first gas oil stream) to effect the desired hydroconversion processes and take advantage of the different reactivities of the first and second gas oil streams. In some embodiments, the second gas oil stream is blended with the first gas oil stream in a ratio of at least 0.10 kg of said second gas oil stream per kg first gas oil stream but not more than

about 0.90 kg of said second gas oil stream per kg first gas oil stream. In other embodiments, the second gas oil stream is blended with the first gas oil stream in a ratio of at least 0.65 kg of said second gas oil stream per kg first gas oil stream but not more than about 0.90 kg of said second gas oil stream per kg first gas oil stream. In yet other embodiments, the second gas oil stream is blended with the first gas oil stream in a ratio of at least 0.8 kg of said second gas oil stream per kg first gas oil stream but not more than about 0.90 kg of said second gas oil stream per kg first gas oil stream.

[0018] The mixed gas oil stream and hydrogen may be contacted with a first hydroconversion catalyst in a first hydrocracker reaction system to convert at least a portion of the hydrocarbons in the mixed gas oil stream to distillate hydrocarbons. An effluent recovered from the first hydrocracker reaction system may include unconverted hydrocarbons and the distillate hydrocarbons. The effluent from the first hydrocracker reaction system may be fractionated into one or more hydrocarbon fractions including a fraction comprising the unconverted hydrocarbons.

[0019] Hydrogen and the fraction comprising the unconverted hydrocarbons may be contacted with a second hydroconversion catalyst in a second hydrocracker reaction system to convert at least a portion of the hydrocarbons in the mixed gas oil stream to distillate hydrocarbons. The effluent from the second hydrocracking reaction system may be fed to the fractionating step for concurrent fractionation with the effluent from the first hydrocracker reaction system.

[0020] Hydrogen and the second portion of the first gas oil stream may be contacted with a third hydroconversion catalyst in a third hydrocracker reaction system to convert at least a portion of the hydrocarbons in the second portion to distillate hydrocarbons. The effluent from the third hydrocracker reaction system may then be fractionated to recover two or more hydrocarbon fractions.

[0021] Concurrent separation or fractionation of the effluent from the first and second hydrocracker reaction systems may include initially feeding the effluents from the first and second hydrocracker reaction systems to a vapor-liquid separator to recover a vapor fraction and a liquid fraction. The liquid fraction may then be fractionated in one or more distillation columns into the one or more hydrocarbon fractions including a fraction comprising the unconverted hydrocarbons. In some embodiments, the

liquid fraction may be separated to recover a C4- fraction, a light naphtha fraction, a heavy naphtha fraction, a kerosene fraction, a diesel fraction, and a base oil fraction.

[0022] Separation or fractionation of the effluent from the third hydrocracker reaction system also may include initially feeding the effluent to a vapor-liquid separator to recover a vapor fraction and a liquid fraction. The liquid fraction may then be fractionated in one or more distillation columns into the one or more hydrocarbon fractions including a fraction comprising the unconverted hydrocarbons. In some embodiments, the liquid fraction may be separated to recover a C4- fraction, a light naphtha fraction, a heavy naphtha fraction, a kerosene fraction, a diesel fraction, and a base oil fraction.

[0023] In some embodiments, the effluent from the third hydrocracker reaction system may be fed to a common separation system for processing along with the first and second effluents.

[0024] In some embodiments, an effluent from a diesel hydrotreating unit may also be fed to the separation system processing the effluent from the third hydrocracker reaction system. Where a diesel hydrotreating unit effluent is co-processed, embodiments disclosed herein may include the steps of: hydrotreating a hydrocarbon feedstock in a diesel hydrotreating unit; recovering an effluent from the diesel hydrotreating unit; and feeding the effluent from the diesel hydrotreating unit to the fractionating step for concurrent fractionation with the effluent from the third hydrocracker reaction system.

[0025] The vapor fractions recovered from the vapor-liquid separators may contain unreacted hydrogen. At least a portion of the vapor fraction is recycled in some embodiments to one or more of the first hydrocracker reaction system, the second hydrocracker reaction system, the third hydrocracker reaction system, and the distillate hydrotreating system.

[0026] In some embodiments, at least a portion of the base oil fraction recovered from the effluent from the third hydrocracker reaction system may be fed to the second hydrocracker reaction system. The added process flexibility afforded by flow lines providing this option may allow the system to adjust to seasonal demands for fuels and/or base oils and lube oils as needed.

- [0027] The first hydrocracking reactor system may be operated to achieve at least 30% conversion in some embodiments; at least 40% conversion in other embodiments; and at least 50% conversion in yet other embodiments.
- [0028] The second hydrocracking reactor system may be operated to achieve at least 45% conversion in some embodiments; at least 55% conversion in other embodiments; and at least 70% conversion in yet other embodiments.
- [0029] The third hydrocracking reactor system may be operated to achieve at least 50% conversion in some embodiments; at least 60% conversion in other embodiments; and at least 70% conversion in yet other embodiments.
- [0030] The reaction severity for the first hydrocracking reaction system may be at least about 35,000 °F-Bara-Hr but no more than about 225,000 °F-Bara-Hr. The reaction severity for the second hydrocracking reaction system may be at least about 25,000 °F-Bara-Hr but no more than about 110,000 °F-Bara-Hr. The reaction severity for the third hydrocracking reaction system may be at least about 50,000 °F-Bara-Hr but no more than about 235,000 °F-Bara-Hr.
- [0031] Embodiments disclosed herein also relate to a system for upgrading gas oils to distillate hydrocarbons. The system may include a flow control system for dividing a first gas oil stream into a first and second portions. A mixing device may then be used for mixing a second gas oil stream and the first portion of the first gas oil stream to form a mixed gas oil stream. Mixing devices useful in embodiments herein may include mixing tees, agitated vessels, pumps, pump around loops, and other mixing devices known to those in the art.
- [0032] A first hydrocracker reaction system may then be used for contacting the mixed gas oil stream and hydrogen with a first hydroconversion catalyst to convert at least a portion of the hydrocarbons in the mixed gas oil stream to distillate hydrocarbons. A separation system is used for fractionating an effluent from the first hydrocracker reaction system into one or more hydrocarbon fractions including a fraction comprising the unconverted hydrocarbons.
- [0033] A second hydrocracker reaction system may be used for contacting hydrogen and the fraction comprising the unconverted hydrocarbons with a second hydroconversion catalyst to convert at least a portion of the hydrocarbons in the

mixed gas oil stream to distillate hydrocarbons. The system may also include a flow line for feeding the effluent from the second hydrocracking reaction system to the fractionating system for concurrent fractionation with the effluent from the first hydrocracker reaction system;

[0034] A third hydrocracker reaction system may be used for contacting hydrogen and the second portion of the first gas oil stream with a third hydroconversion catalyst to convert at least a portion of the hydrocarbons in the second portion to distillate hydrocarbons. The effluent from the third hydrocracker reaction system may then be forwarded to a separation system for fractionating an effluent from the third hydrocracker reaction system to recover two or more hydrocarbon fractions.

[0035] Systems according to embodiments herein may also include at least one of a delayed coking system, a fluid coking system, a visbreaking system, a steam cracking system, and a fluid catalytic cracking system for producing the second gas oil stream.

[0036] The flow control system is configured in some embodiments to blend the second gas oil stream with the first gas oil stream in a ratio of at least 0.10 kg of said second gas oil stream per kg first gas oil stream but not more than about 0.90 kg of said second gas oil stream per kg first gas oil stream. In other embodiments, the flow control system is configured to blend the second gas oil stream with the first gas oil stream in a ratio of at least 0.65 kg of said second gas oil stream per kg first gas oil stream but not more than about 0.90 kg of said second gas oil stream per kg first gas oil stream. In yet other embodiments, the flow control system is configured to blend the second gas oil stream with the first gas oil stream at a ratio of at least 0.8 kg of said second gas oil stream per kg first gas oil stream but not more than about 0.90 kg of said second gas oil stream per kg first gas oil stream.

[0037] The separation system for fractionating the effluent from the first and second hydrocracker reaction systems may include: a vapor-liquid separator for separating the first and second hydrocracker reaction systems into a vapor fraction and a liquid fraction, and a fractionation system for fractionating the liquid fraction into the one or more hydrocarbon fractions including a fraction comprising the unconverted hydrocarbons. One or more flow lines may be used to recycle at least a portion of the vapor fraction to one or more of the first hydrocracker reaction system, the second

hydrocracker reaction system, the third hydrocracker reaction system, and a distillate hydrotreating system.

[0038] In some embodiments, the separation system for fractionating the effluent from the third hydrocracker reaction system is a common separation system with that for separating the effluents from the first and second hydrocracker reaction systems.

[0039] The systems for processing gas oils according to embodiments herein may also include a diesel hydrotreating unit for hydrotreating a hydrocarbon feedstock and a flow conduit for feeding the effluent from the diesel hydrotreating unit to the separation system for fractionating step for concurrent fractionation with the effluent from the third hydrocracker reaction system.

[0040] The separation system for fractionating the effluent from the third hydrocracker reaction system may be configured to fractionate the effluent into a C4-fraction, a light naphtha fraction, a heavy naphtha fraction, a kerosene fraction, a diesel fraction, and a base oil fraction. A flow conduit may be provided for feeding at least a portion of the base oil fraction to the second hydrocracker reaction system.

[0041] The system may include an operating system configured to: operate the first hydrocracking reactor system to achieve at least 30% conversion and more preferably at least 40% conversion and most preferably at least 50% conversion; operate the second hydrocracking reactor system to achieve at least 45% conversion and more preferably at least 55% conversion and most preferably at least 70% conversion; and operate the third hydrocracking reactor system to achieve at least 50% conversion and more preferably at least 60% conversion and most preferably at least 70% conversion. The operating system may also be configured to control: the reaction severity for the first hydrocracking reaction system in the range from about 35,000 °F-Bara-Hr to less than about 225,000 °F-Bara-Hr; the reaction severity for the second hydrocracking reaction system in the range from about 25,000 °F-Bara-Hr to less than about 110,000 °F-Bara-Hr; and the reaction severity for the third hydrocracking reaction system in the range from about 50,000 °F-Bara-Hr to less than about 235,000 °F-Bara-Hr.

[0042] Referring now to Figure 1, a simplified process flow diagram of processes for upgrading gas oils according to embodiments herein is illustrated. A first gas oil stream 10 and a second gas oil stream 12 are fed to the system. A portion 14 of the

first gas oil stream 10 may be mixed with the second gas oil stream 14 at a specified split gas oil ratio to form a mixed gas oil stream 16.

- [0043]** The mixed gas oil stream 16 and hydrogen 18 (which may include fresh or make-up hydrogen 20 as well as recycle hydrogen 22) may be contacted with a first hydroconversion catalyst 24 in a first hydrocracker reaction system 26 to convert at least a portion of the hydrocarbons in the mixed gas oil stream to distillate hydrocarbons. Recycle or fresh hydrogen may also be fed intermediate one or more catalyst beds 24 in reaction system 26.
- [0044]** An effluent 28 recovered from the first hydrocracker reaction system may include unconverted hydrocarbons and the distillate hydrocarbons. The effluent 28 from the first hydrocracker reaction system 26 may then be fed to vapor-liquid separator 30 to recover a vapor fraction 32 and a liquid fraction 34. The liquid fraction may then be fed to a fractionation system 36 to fractionate the liquid fraction 34 into a C4- fraction 38, a light naphtha fraction 40, a heavy naphtha fraction 42, a kerosene fraction 44, a diesel fraction 46, and a base oil fraction 48.
- [0045]** Base oil fraction 48 and hydrogen (which may include fresh or make-up hydrogen 50 as well as recycle hydrogen 52) may be contacted with a second hydroconversion catalyst 54 in a second hydrocracker reaction system 56 to convert at least a portion of the hydrocarbons in the base oil stream to distillate hydrocarbons. Recycle or fresh hydrogen may also be fed intermediate one or more catalyst beds 54 in reaction system 56.
- [0046]** The effluent 58 from the second hydrocracking reaction system 56 may be fed to the vapor-liquid separator 30 and frationator 36 for concurrent fractionation with the effluent 28 from the first hydrocracker reaction system 26.
- [0047]** The second portion 60 of the first gas oil stream 10 and hydrogen (which may include fresh or make-up hydrogen 66 as well as recycle hydrogen 68) may be contacted with a third hydroconversion catalyst 62 in a third hydrocracker reaction system 64 to convert at least a portion of the hydrocarbons in the second portion 60 to distillate hydrocarbons. Recycle or fresh hydrogen may also be fed intermediate one or more catalyst beds 62 in reaction system 64.
- [0048]** An effluent 70 recovered from the third hydrocracker reaction system may include unconverted hydrocarbons and distillate hydrocarbons. The effluent 70 from

the third hydrocracker reaction system 64 may then be fed to vapor-liquid separator 72 to recover a vapor fraction 74 and a liquid fraction 76. The liquid fraction may then be fed to a fractionation system 78 to fractionate the liquid fraction 76 into a C4-fraction 80, a light naphtha fraction 82, a heavy naphtha fraction 84, a kerosene fraction 86, a diesel fraction 88, and a base oil fraction 90.

[0049] In some embodiments, a hydrocarbon feed 92 and hydrogen (which may include at least one of fresh or make-up hydrogen feed (not illustrated) and recycle hydrogen 98) may be provided to a diesel hydrotreating reactor 94 hydrotreatment of the hydrocarbon feed over a hydrotreatment catalyst 96. The effluent 100 from diesel hydrotreating reactor 94 may be co-processed with effluent 70 from the third hydrocracker reactor system 64 in vapor-liquid separator 72 and fractionation system 78.

[0050] Vapor fraction 74 and vapor fraction 32 may be rich in unreacted hydrogen. In some embodiments, these vapor fractions may be recycled to one or more of reactor systems 26, 64, and 56, as well as 94 when present. As illustrated in Figure 1, vapor fractions 32, 74 may be combined to form recycle vapor fraction 110 which may then be distributed via flow lines 22, 52, 68 as required to the respective reactor feed lines and interstage feed ports.

[0051] In some embodiments, process flexibility with respect to fuel or oil production may be afforded by feeding a portion of the base oil fraction 90 via flow line 112 to second hydrocracker reaction system 56.

[0052] As described above, the process of Figure 1 is a two stage recycle scheme that may be used to process refractory feeds such as HCGO and HVGO. The process may be used to maximize diesel with severe cold flow property specifications, along with providing the flexibility to produce feed for Group III lube base oils production.

[0053] This processing scheme may be useful, for example, with Heavy Vacuum Gas oil (HVGO) from WestSiberian and Sakhalin crudes and Heavy Coker Gas Oil (HCGO) to maximize the production of Euro-V diesel - with an option to produce feed for the Group III lubes. The system may also be integrated with a hydrotreating unit to upgrade distillates using the split-feed injection technology.

[0054] HVGO and HCGO are processed in parallel first-stage reactor systems with a shared second stage. When the unit operates in fuels mode, the unconverted oil

(UCO) from the VGO section is mixed with UCO from the HCGO section and hydrocracked to extinction in the common second stage. In base oil production mode, the UCO bleed is fed to the lube oil unit.

[0055] Catalyst bed 24, 54, 62 and 96 may include the same or different catalysts. Catalyst beds within the individual reactors may also include a single catalyst in all beds of the reactor, mixtures of catalysts within a single bed or different catalysts in different beds. A catalyst system useful for the first stage hydrocracking reactor system reactor, processing as high as 65% HCGO, may include a primarily Ni-Mo hydrotreating catalyst followed by a high activity middle distillate selective hydrocracking catalysts.

[0056] The third stage hydrocracker reactor, processing HVGO, may be loaded with high middle distillate selective hydrocracking catalyst. The catalyst system is tailored for increasing the Viscosity Index (VI) of the UCO to a level where, after dewaxing, Group III base oils can be produced.

[0057] The second stage hydrocracker reactor system may include a high distillate selective, high hydrogenation function, second-stage catalyst.

[0058] Embodiments disclosed herein provide a novel integrated scheme for the processing of gas oils and especially reactive gas oils produced by thermal cracking of residua using a split flow concept. Table 1 compares the relative reaction severities and feed types for each of the three hydrocracking reaction systems used in processes disclosed herein.

	First Hydrocracker Reaction System	Third Hydrocracker Reaction System	Second Hydrocracker Reaction System
Severity	Intermediate	Highest	Lowest
Feed	Mix of VGO and thermally cracked VGO	VGO	UCO from 1 st and 3 rd hydrocracker reaction systems

[0059] Table 2 compares the operating ranges defined for each reactor stage as described above for some embodiments disclosed herein.

	First Hydrocracker Reaction System	Third Hydrocracker Reaction System	Second Hydrocracker

			Reaction System
Severity Range	Intermediate	Highest	Lowest
Min Temp Range, °F	710	710	650
Max Temp Range, °F	750	760	690
Preferred Temp Range, °F	735-745	730-740	665-685
Min LHSV	0.5	0.5	1.0
Max LHSV	1.1	0.9	1.5
Preferred LHSV range	0.6-0.8	0.5-0.7	1.0-1.4
Max H2 partial pressure range, Bara	145	152	152
Min H2 partial pressure range, Bara	105	115	105
Preferred H2 partial pressure range, Bara	138	138	138
Min % Conversion	40	60	45
Max % Conversion	50	75	75
Preferred % Conversion Range	40-50	60-70	55-70

[0060] For the ranges of conditions shown in the Table 2, the range of maximum and minimum reactor severities is defined as shown in Table 3.

Reactor Severity, °F-Bara-Hr					
First Hydrocracker Reaction System		Third Hydrocracker Reaction System		Second Hydrocracker Reaction System	
Min	Max	Min	Max	Min	Max
36260	220140	51000	236700	24000	110000

[0061] As described above, embodiments disclosed herein provide for a split flow scheme for processing of gas oils. The split flow concept may allow optimization of the hydrocracking reactor severities and thereby take advantage of the different reactivities of thermally cracked gas oils versus those of virgin gas oils. This results in a lower cost facility for producing base oils as well as diesel, kerosene and gasoline fuels while achieving high conversions and high catalyst lives.

[0062] Advantageously, embodiments disclosed herein may effectively integrate fixed-bed residue hydrotreatment with Resid Hydrocracking. Embodiments disclosed herein may also avoid building two separate hydrocrackers, one for lube base oil product

and one for transportation fuel product. Lower investment cost (common recycle compressor, make-up compressor, and other high pressure loop equipment) may also be realized.

[0063] While the disclosure includes a limited number of embodiments, those skilled in the art, having benefit of this disclosure, will appreciate that other embodiments may be devised which do not depart from the scope of the present disclosure. Accordingly, the scope should be limited only by the attached claims.

CLAIMS

What is claimed:

1. A process for upgrading gas oils to distillate hydrocarbons, the process comprising:
 - dividing a first gas oil stream into a first and second portions;
 - mixing a second gas oil stream and the first portion of the first gas oil stream to form a mixed gas oil stream;
 - contacting the mixed gas oil stream and hydrogen with a first hydroconversion catalyst in a first hydrocracker reaction system to convert at least a portion of the hydrocarbons in the mixed gas oil stream to distillate hydrocarbons;
 - recovering an effluent from the first hydrocracker reaction system comprising unconverted hydrocarbons and the distillate hydrocarbons;
 - fractionating the effluent from the first hydrocracker reaction system into one or more hydrocarbon fractions including a fraction comprising the unconverted hydrocarbons;
 - contacting hydrogen and the fraction comprising the unconverted hydrocarbons with a second hydroconversion catalyst in a second hydrocracker reaction system to convert at least a portion of the hydrocarbons in the mixed gas oil stream to distillate hydrocarbons;
 - feeding the effluent from the second hydrocracking reaction system to the fractionating step for concurrent fractionation with the effluent from the first hydrocracker reaction system;
 - contacting hydrogen and the second portion of the first gas oil stream with a third hydroconversion catalyst in a third hydrocracker reaction system to convert at least a portion of the hydrocarbons in the second portion to distillate hydrocarbons;
 - fractionating an effluent from the third hydrocracker reaction system to recover two or more hydrocarbon fractions.
2. The process of claim 1, wherein the first gas oil stream comprises gas oils derived from one or more of petroleum crudes, shale oils, tar sands bitumen, coal-derived oils, tall oils, black oils, and bio-oils and having an atmospheric equivalent, initial boiling point of about 650-680F based on ASTM method D1160 or equivalent, and wherein the second gas oil stream comprises gas oils produced from thermal or catalytic cracking of heavy oils and having an initial boiling point of about 650-680F based on ASTM method D1160 or equivalent.

3. The process of claim 2, wherein the second gas oil stream comprises gas oils produced by at least one of delayed coking, fluid coking, visbreaking, steam cracking, and fluid catalytic cracking.
4. The process of claim 1, wherein the second gas oil stream is blended with the first gas oil stream in a ratio of at least 0.10 kg of said second gas oil stream per kg first gas oil stream but not more than about 0.90 kg of said second gas oil stream per kg first gas oil stream.
5. The process of claim 1, wherein the second gas oil stream is blended with the first gas oil stream in a ratio of at least 0.65 kg of said second gas oil stream per kg first gas oil stream but not more than about 0.90 kg of said second gas oil stream per kg first gas oil stream.
6. The process of claim 1, wherein the second gas oil stream is blended with the first gas oil stream in a ratio of at least 0.8 kg of said second gas oil stream per kg first gas oil stream but not more than about 0.90 kg of said second gas oil stream per kg first gas oil stream.
7. The process of claim 1, wherein fractionating the effluent from the first and second hydrocracker reaction systems comprises:
 - feeding the effluents from the first and second hydrocracker reaction systems to a vapor-liquid separator to recover a vapor fraction and a liquid fraction;
 - fractionating the liquid fraction into the one or more hydrocarbon fractions including a fraction comprising the unconverted hydrocarbons.
8. The process of claim 7, wherein at least a portion of the vapor fraction is recycled to one or more of the first hydrocracker reaction system, the second hydrocracker reaction system, the third hydrocracker reaction system, and a distillate hydrotreating system.
9. The process of claim 1, wherein the effluent from the third hydrocracker reaction system is fractionated in a common fractionation system with the effluents from the first and second hydrocracker reaction systems.
10. The process of claim 1, further comprising:
 - hydrotreating a hydrocarbon feedstock in a diesel hydrotreating unit;
 - recovering an effluent from the diesel hydrotreating unit;
 - feeding the effluent from the diesel hydrotreating unit to the fractionating step for concurrent fractionation with the effluent from the third hydrocracker reaction system.
11. The process of claim 1, wherein the fractionating the effluent from the third hydrocracker reaction system comprises fractionating the effluent into a C4- fraction, a light naphtha

- fraction, a heavy naphtha fraction, a kerosene fraction, a diesel fraction, and a base oil fraction.
12. The process of claim 11, further comprising feeding at least a portion of the base oil fraction to the second hydrocracker reaction system.
13. The process of claim 1, further comprising:
operating the first hydrocracking reactor system to achieve at least 30% conversion and more preferably at least 40% conversion and most preferably at least 50% conversion;
operating the second hydrocracking reactor system to achieve at least 45% conversion and more preferably at least 55% conversion and most preferably at least 70% conversion;
and
operating the third hydrocracking reactor system to achieve at least 50% conversion and more preferably at least 60% conversion and most preferably at least 70% conversion,
wherein conversion is defined as the hydrocracking of hydrocarbon materials boiling above about 650°F to hydrocarbon materials boiling below about 650°F, both temperatures as defined by ASTM D 1160 or equivalent distillation method.
14. The process of claim 13,
wherein the reaction severity for the first hydrocracking reaction system is at least about 35,000 °F-Bara-Hr but no more than about 225,000 °F-Bara-Hr;
wherein the reaction severity for the second hydrocracking reaction system is at least about 25,000 °F-Bara-Hr but no more than about 110,000 °F-Bara-Hr; and
wherein the reaction severity for the third hydrocracking reaction system is at least about 50,000 °F-Bara-Hr but no more than about 235,000 °F-Bara-Hr,
wherein reaction severity is defined as the catalyst average temperature in degrees Fahrenheit of the catalysts loaded in the hydrocracking reactors of a hydrocracking reactor system multiplied by the average hydrogen partial pressure of said hydrocracking reactors in Bar absolute and divided by the liquid hourly space velocity in said hydrocracking reactors.
15. A system for upgrading gas oils to distillate hydrocarbons, the system comprising:
a flow control system for dividing a first gas oil stream into a first and second portions;
a mixing device for mixing a second gas oil stream and the first portion of the first gas oil stream to form a mixed gas oil stream;

- a first hydrocracker reaction system for contacting the mixed gas oil stream and hydrogen with a first hydroconversion catalyst to convert at least a portion of the hydrocarbons in the mixed gas oil stream to distillate hydrocarbons;
 - a separation system for fractionating an effluent from the first hydrocracker reaction system into one or more hydrocarbon fractions including a fraction comprising the unconverted hydrocarbons;
 - a second hydrocracker reaction system for contacting hydrogen and the fraction comprising the unconverted hydrocarbons with a second hydroconversion catalyst to convert at least a portion of the hydrocarbons in the mixed gas oil stream to distillate hydrocarbons;
 - a flow line for feeding the effluent from the second hydrocracking reaction system to the fractionating system for concurrent fractionation with the effluent from the first hydrocracker reaction system;
 - a third hydrocracker reaction system for contacting hydrogen and the second portion of the first gas oil stream with a third hydroconversion catalyst to convert at least a portion of the hydrocarbons in the second portion to distillate hydrocarbons;
 - a separation system for fractionating an effluent from the third hydrocracker reaction system to recover two or more hydrocarbon fractions.
16. The system of claim 15, further comprising at least one of a delayed coking system, a fluid coking system, a visbreaking system, a steam cracking system, and a fluid catalytic cracking system for producing the second gas oil stream.
 17. The system of claim 15, wherein the flow control system is configured to blend the second gas oil stream with the first gas oil stream in a ratio of at least 0.10 kg of said second gas oil stream per kg first gas oil stream but not more than about 0.90 kg of said second gas oil stream per kg first gas oil stream.
 18. The system of claim 15, wherein the flow control system is configured to blend the second gas oil stream with the first gas oil stream in a ratio of at least 0.65 kg of said second gas oil stream per kg first gas oil stream but not more than about 0.90 kg of said second gas oil stream per kg first gas oil stream.
 19. The system of claim 15, wherein the flow control system is configured to blend the second gas oil stream with the first gas oil stream at a ratio of at least 0.8 kg of said

second gas oil stream per kg first gas oil stream but not more than about 0.90 kg of said second gas oil stream per kg first gas oil stream.

20. The system of claim 15, wherein the separation system for fractionating the effluent from the first and second hydrocracker reaction systems comprises:
 - a vapor-liquid separator for separating the first and second hydrocracker reaction systems into a vapor fraction and a liquid fraction;
 - a fractionation system for fractionating the liquid fraction into the one or more hydrocarbon fractions including a fraction comprising the unconverted hydrocarbons.
21. The system of claim 20, further comprising one or more flow lines to recycle at least a portion of the vapor fraction to one or more of the first hydrocracker reaction system, the second hydrocracker reaction system, the third hydrocracker reaction system, and a distillate hydrotreating system.
22. The system of claim 15, wherein the separation system for fractionating the effluent from the third hydrocracker reaction system is a common separation system with that for separating the effluents from the first and second hydrocracker reaction systems.
23. The system of claim 15, further comprising:
 - a diesel hydrotreating unit for hydrotreating a hydrocarbon feedstock;
 - a flow conduit for feeding the effluent from the diesel hydrotreating unit to the separation system for fractionating step for concurrent fractionation with the effluent from the third hydrocracker reaction system.
24. The system of claim 15, wherein the separation system for fractionating the effluent from the third hydrocracker reaction system is configured to fractionate the effluent into a C4-fraction, a light naphtha fraction, a heavy naphtha fraction, a kerosene fraction, a diesel fraction, and a base oil fraction.
25. The system of claim 11, further comprising a flow conduit for feeding at least a portion of the base oil fraction to the second hydrocracker reaction system.
26. The system of claim 1, further comprising an operating system configured to:
 - operate the first hydrocracking reactor system to achieve at least 30% conversion and more preferably at least 40% conversion and most preferably at least 50% conversion;
 - operate the second hydrocracking reactor system to achieve at least 45% conversion and more preferably at least 55% conversion and most preferably at least 70% conversion; and
 - operate the third hydrocracking reactor system to achieve at least 50% conversion and more preferably at least 60% conversion and most preferably at least 70% conversion,

wherein conversion is defined as the hydrocracking of hydrocarbon materials boiling above about 650°F to hydrocarbon materials boiling below about 650°F, both temperatures as defined by ASTM D 1160 or equivalent distillation method.

27. The system of claim 13, wherein the operating system is configured for controlling:
- the reaction severity for the first hydrocracking reaction system in the range from about 35,000 °F-Bara-Hr to less than about 225,000 °F-Bara-Hr;
 - the reaction severity for the second hydrocracking reaction system in the range from about 25,000 °F-Bara-Hr to less than about 110,000 °F-Bara-Hr; and
 - the reaction severity for the third hydrocracking reaction system in the range from about 50,000 °F-Bara-Hr to less than about 235,000 °F-Bara-Hr,
- wherein reaction severity is defined as the catalyst average temperature in degrees Fahrenheit of the catalysts loaded in the hydrocracking reactors of a hydrocracking reactor system multiplied by the average hydrogen partial pressure of said hydrocracking reactors in Bar absolute and divided by the liquid hourly space velocity in said hydrocracking reactors.

INTERNATIONAL SEARCH REPORT

International application No.
PCT/US2014/015907**A. CLASSIFICATION OF SUBJECT MATTER****C10G 65/02(2006.01)i, C10L 1/14(2006.01)i**

According to International Patent Classification (IPC) or to both national classification and IPC

B. FIELDS SEARCHEDMinimum documentation searched (classification system followed by classification symbols)
C10G 65/02; C10G 47/24; C10G 47/16; C10G 51/06; C10G 45/00; C10G 65/18; C10L 1/14Documentation searched other than minimum documentation to the extent that such documents are included in the fields searched
Korean utility models and applications for utility models
Japanese utility models and applications for utility modelsElectronic data base consulted during the international search (name of data base and, where practicable, search terms used)
eKOMPASS(KIPO internal) & keywords: gas oil, dividing, mixing, second hydrocracking, fractionating**C. DOCUMENTS CONSIDERED TO BE RELEVANT**

Category*	Citation of document, with indication, where appropriate, of the relevant passages	Relevant to claim No.
Y	US 5904835 A (THAKKAR, VASANT P.) 18 May 1999 See column 5, line 8 - column 7, line 10; claims 1-9; and figure.	1-27
Y	US 6113775 A (CHRISTOLINI, BEN A. et al.) 5 September 2000 See column 2, line 64 - column 4, line 64, column 7, line 5 - column 9, line 55; claims 1-12; and figure.	1-27
A	US 6787025 B2 (MUKHERJEE, UJJAL KUMAR et al.) 7 September 2004 See column 1, lines 11-35, column 3, line 5 - column 6, line 3; claims 1-15; and figures 1-2	1-27
A	US 2004-0173503 A1 (STUPIN, STEVEN et al.) 9 September 2004 See paragraphs [0021]-[0034]; claims 1-24; and figures 2-3.	1-27
A	US 4404088 A (BACHTEL, ROBERT W. et al.) 13 September 1983 See column 4, line 47 - column 5, line 40; claims 1-4; and figure 2.	1-27

 Further documents are listed in the continuation of Box C. See patent family annex.

* Special categories of cited documents:

"A" document defining the general state of the art which is not considered to be of particular relevance

"E" earlier application or patent but published on or after the international filing date

"L" document which may throw doubts on priority claim(s) or which is cited to establish the publication date of another citation or other special reason (as specified)

"O" document referring to an oral disclosure, use, exhibition or other means

"P" document published prior to the international filing date but later than the priority date claimed

"T" later document published after the international filing date or priority date and not in conflict with the application but cited to understand the principle or theory underlying the invention

"X" document of particular relevance; the claimed invention cannot be considered novel or cannot be considered to involve an inventive step when the document is taken alone

"Y" document of particular relevance; the claimed invention cannot be considered to involve an inventive step when the document is combined with one or more other such documents, such combination being obvious to a person skilled in the art

"&" document member of the same patent family

Date of the actual completion of the international search

19 May 2014 (19.05.2014)

Date of mailing of the international search report

19 May 2014 (19.05.2014)

Name and mailing address of the ISA/KR

 International Application Division
 Korean Intellectual Property Office
 189 Cheongsa-ro, Seo-gu, Daejeon Metropolitan City, 302-701,
 Republic of Korea

Facsimile No. +82-42-472-7140

Authorized officer

LEE, Dong Wook

Telephone No. +82-42-481-8163



INTERNATIONAL SEARCH REPORT

Information on patent family members

International application No.

PCT/US2014/015907

Patent document cited in search report	Publication date	Patent family member(s)	Publication date
US 5904835 A	18/05/1999	None	
US 6113775 A	05/09/2000	None	
US 6787025 B2	07/09/2004	AU 2002-302134 B2 AU 2003-218332 A1 AU 2003-218332 B2 CA 2414441 A1 CA 2414441 C CA 2479287 A1 CA 2479287 C CA 2668788 A1 CN 1245484 C CN 1432629 A DE 60219128 D1 DE 60219128 T2 EP 1319701 A1 EP 1319701 B1 EP 1487941 A1 JP 04434750 B2 JP 04672000 B2 JP 2005-520918 A JP 2008-121019 A KR 10-0930985 B1 KR 10-2003-0051374 A US 2003-0111386 A1 US 2003-0111387 A1 US 6797154 B2 WO 03-080769 A1	06/11/2008 08/10/2003 27/11/2008 17/06/2003 15/09/2009 02/10/2003 22/06/2010 02/10/2003 15/03/2006 30/07/2003 10/05/2007 12/07/2007 18/06/2003 28/03/2007 22/12/2004 17/03/2010 20/04/2011 14/07/2005 29/05/2008 10/12/2009 25/06/2003 19/06/2003 19/06/2003 28/09/2004 02/10/2003
US 2004-0173503 A1	09/09/2004	CA 2481149 A1 CA 2481149 C EP 1492604 A1 JP 04504025 B2 JP 2005-521784 A US 7238275 B2 WO 03-086567 A1	23/10/2003 22/02/2011 05/01/2005 14/07/2010 21/07/2005 03/07/2007 23/10/2003
US 4404088 A	13/09/1983	None	