

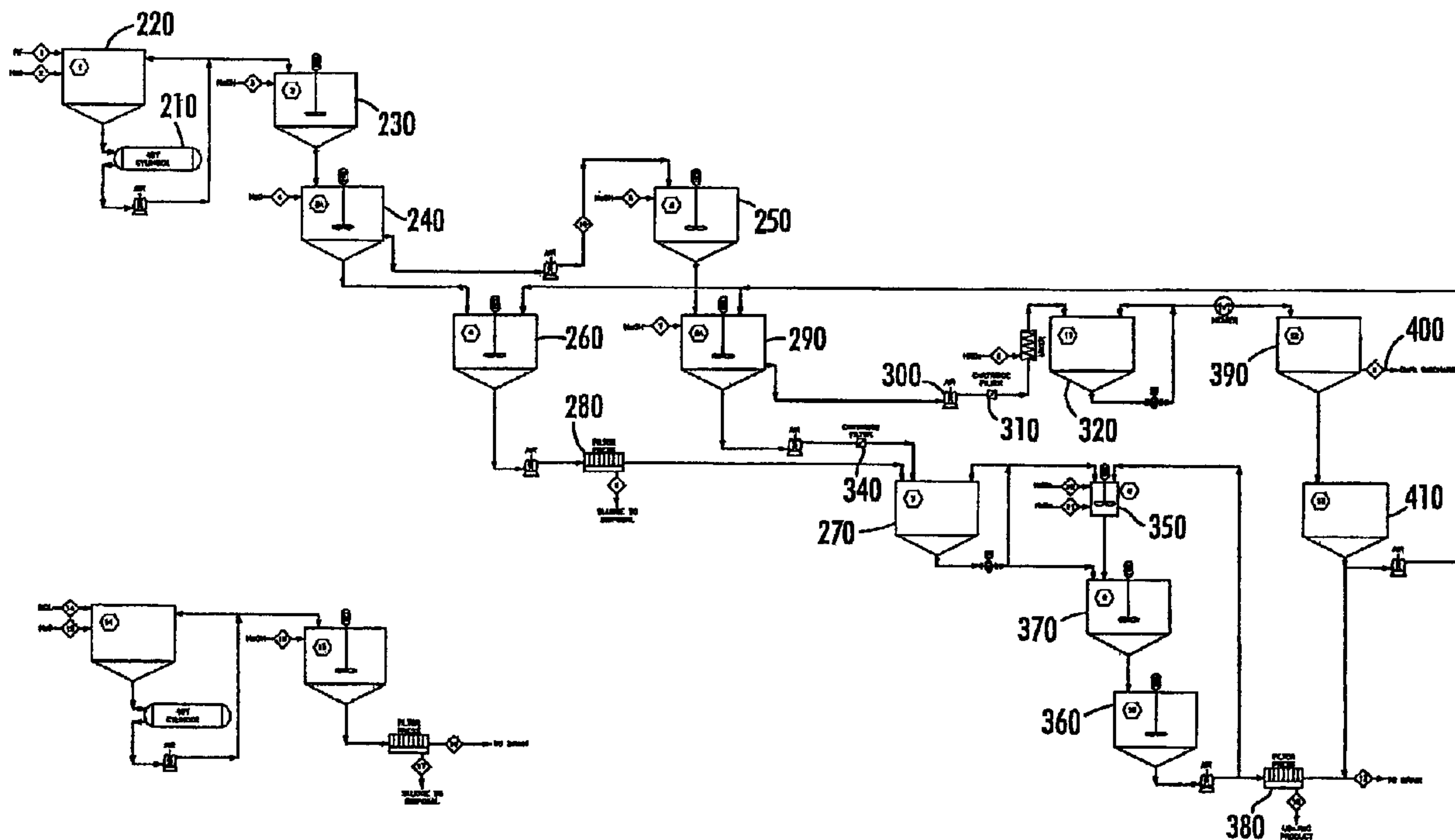

(22) Date de dépôt/Filing Date: 2014/02/24
 (41) Mise à la disp. pub./Open to Public Insp.: 2014/08/26
 (45) Date de délivrance/Issue Date: 2016/02/16
 (30) Priorité/Priority: 2013/02/26 (US13/776,785)

(51) Cl.Int./Int.Cl. *C01G 43/00* (2006.01),
C22B 3/06 (2006.01), *C22B 3/46* (2006.01),
C22B 60/02 (2006.01), *C22B 7/00* (2006.01)
 (72) Inventeur/Inventor:
 NOE, RONALD O., US
 (73) Propriétaire/Owner:
 TRANSPORT LOGISTICS INTERNATIONAL, INC., US
 (74) Agent: GOWLING LAFLEUR HENDERSON LLP

(54) Titre : RECUPERATION D'URANIUM A PARTIR DE CYLINDRES UF₆
 (54) Title: URANIUM RECOVERY FROM UF₆ CYLINDERS



(57) Abrégé/Abstract:

A process for recovering residual uranium from emptied uranium hexafluoride shipping cylinder during cleaning, including rinsing a uranium hexafluoride shipping cylinder with hydrofluoric acid to dissolve a heel of uranium hexafluoride therein to form a mixture of sediment, precipitates and a uranium solution; separating the uranium solution from the sediment and precipitates; mixing sodium hydroxide with the uranium solution to precipitate sodium diuranate; separating the solid sodium diuranate from the sodium fluoride solution formed; re-dissolving the sodium diuranate in sodium carbonate solution to form uranyl carbonate complex solution; and adjusting the pH of uranyl carbonate complex solution further to precipitate uranyl peroxide with the addition of hydrogen peroxide. Sodium fluoride solution produced is further treated to remove fluoride by percolating it through a calcite limestone bed to form calcium fluoride solid.

ABSTRACT OF THE DISCLOSURE

A process for recovering residual uranium from emptied uranium hexafluoride shipping cylinder during cleaning, including rinsing a uranium hexafluoride shipping cylinder with hydrofluoric acid to dissolve a heel of uranium hexafluoride therein to form a mixture of sediment, precipitates and a uranium solution; separating the uranium solution from the sediment and precipitates; mixing sodium hydroxide with the uranium solution to precipitate sodium diuranate; separating the solid sodium diuranate from the sodium fluoride solution formed; re-dissolving the sodium diuranate in sodium carbonate solution to form uranyl carbonate complex solution; and adjusting the pH of uranyl carbonate complex solution further to precipitate uranyl peroxide with the addition of hydrogen peroxide. Sodium fluoride solution produced is further treated to remove fluoride by percolating it through a calcite limestone bed to form calcium fluoride solid.

URANIUM RECOVERY FROM UF₆ CYLINDERS

BACKGROUND OF THE INVENTION

Worldwide, commercial quantities of uranium hexafluoride (UF₆) are stored and shipped in certified steel cylinders having 30-inch and 48-inch diameter. In order to remain in use, each of these UF₆ cylinders must be washed internally and re-certified every five years. As part of the cylinder washing process, a small residue of UF₆, called a heel, in the otherwise empty UF₆ cylinder is first flushed with water from the cylinder's interior. Then the UF₆ cylinder is subjected to a series of tests designed to verify its physical integrity. Successful completion of the physical testing re-certifies the UF₆ cylinder for five additional years of service.

Cylinder washing and re-certification testing are usually performed as an ancillary effort at UF₆ fabricators, enrichment facilities or conversion plants.

SUMMARY OF THE INVENTION

The present invention is method for removing the heel and recovering the residual uranium as part of the process of washing and recertifying an empty UF₆ cylinder and doing so in a facility dedicated to this process so that the more rigorous cylinder washing process can be done with economies of scale and to off-set to some extent the cost of cylinder washing by the resale of the valuable uranium recovered, and thereby result in a cleaner UF₆ cylinder that may remain in use longer. The phrase "empty cylinder" is used not in the literal sense (i. e., completely empty) but in the practical sense, that is, all the uranium hexafluoride has been removed from the cylinder

except the residual heel of UF_6 and that trapped by the scale on the cylinder's interior surface. Inevitably, the repeated use of these UF_6 cylinder results in the build-up of the heel of UF_6 . The present method removes that heel as well as the scale.

The present method not only includes steps to remove the heel and the scale but also to recover uranium from the wash solutions that result from the cylinder wash process. A usable, high-purity uranium by-product can be recovered from washing the UF_6 cylinders. Cylinder integrity testing steps, according to the prior art, follow the washing of the cylinders, which testing steps are not part of the present invention.

The invention also relates to a process for recovering residual uranium from empty uranium hexafluoride shipping cylinders during cleaning. This process includes the steps of:

- (a) collecting plural empty uranium hexafluoride cylinders;
- (b) weighing each cylinder of said plural cylinders to determine the mass of a heel of uranium hexafluoride contained by said each cylinder;
- (c) adding hydrofluoric acid to said each cylinder;
- (d) exposing the interior of said each cylinder to said hydrofluoric acid to dissolve said heel and form a uranium solution;
- (e) emptying said uranium solution from each cylinder into a ~~process~~-tank;
- (f) rinsing said each cylinder with water;
- (g) determining a uranium concentration of said water;
- (h) re-rinsing said each cylinder with water if said uranium concentration exceeds 3000 ppm; and
- (i) processing contents of said tank to recover said uranium

BRIEF DESCRIPTION OF THE DRAWINGS

In the drawings,

Fig. 1 is a schematic diagram of the present process, according to an embodiment of the invention.

DETAILED DESCRIPTION OF EMBODIMENTS

The present invention is directed to a method for removing the heel and recovering the residual uranium as part of the process of washing and recertifying an empty UF₆ cylinder and doing so in a facility dedicated to this process so that the more rigorous cylinder washing process can be done with economies of scale and to off-set to some extent the cost of cylinder washing by the resale of the valuable uranium recovered, and thereby result in a cleaner UF₆ cylinder that may remain in use longer. The phrase "empty cylinder" is used not in the literal sense (i.e., completely empty) but in the practical sense, that is, all the uranium hexafluoride has been removed from the cylinder except the residual heel of UF₆ and that trapped by the scale on the cylinder's interior surface. Inevitably, the repeated use of these UF₆ cylinders results in the build-up of the heel of UF₆. The present method removes that heel as well as the scale.

Each UF₆ cylinder is prepared for washing by checking its weight to estimate the residual heel of UF₆. The weight of the heel is related to the amount of HF needed in the first wash solution. The cylinder is then placed on a roll/tilt table (not shown) and the cylinder valve is attached to a supply hose from an HF wash acid supply tank in which a prepared 15 gallon batch of HF serves as the primary wash solution. After accounting for the amount of UF₆ heel, the rinse solution in wash acid supply tank is adjusted by addition of commercially available 49% HF make-up acid to increase the strength of the wash solution so that 15 gallons of 7% HF wash acid can be delivered into each UF₆ cylinder. After the cylinder valve is opened, the 15 gallons of acid is drained into the cylinder from supply tank. The cylinder valve remains open until the

pressure inside the cylinder equilibrates with ambient pressure. Then the valve is closed and the supply hose is disconnected.

The first UF₆ cylinder then is processed through a horizontal/tilt-up/tilt-down roll program on the table to assure the wash solution contacts all the internal surfaces of the container. The tilt/roll program stops with the cylinder valve in the tilt down position. A pump-out hose is then attached to the cylinder valve, the valve opened, and the wash solution pumped from cylinder into a first reaction tank for its first treatment. The cylinder is then raised to the horizontal position and 14 gallons of rinse water is drained through the pump-out hose into the cylinder. The cylinder valve is again closed and the hose disconnected from the cylinder valve. The cylinder proceeds through a second horizontal/tilt-up/tilt-down roll program to thoroughly rinse the cylinder's interior surface. The roll program again stops with the cylinder valve in the tilt-down position. The hose is re-connected and the valve is opened to allow the rinse solution to be pumped into the rinse water batch tank (not shown). A sample of the rinse solution is analyzed for uranium concentration. If the sample contains less than 3,000 ppm uranium, the cylinder is deemed to have been satisfactorily cleaned. The hose is then disconnected from the valve and the cylinder removed from the tilt/roll table.

If the rinse sample result contains more than 3,000 ppm, the rinse water is pumped from the rinse water batch tank to the first reaction tank thereby adding it to the wash solution for the first treatment step. Next a second 14-gallon increment of rinse water is added to the UF₆ cylinder for a second rinse using the tilt-/tilt-down roll program on the tilt-up/tilt-down roll table. This rinse sequence is repeated until the rinse sample tests below 3,000 ppm for uranium.

The washing chemistry and stoichiometric material balances are as follows:



$$352 \text{ g} + 36 \text{ g} = 308 \text{ g} + 80 \text{ g}$$

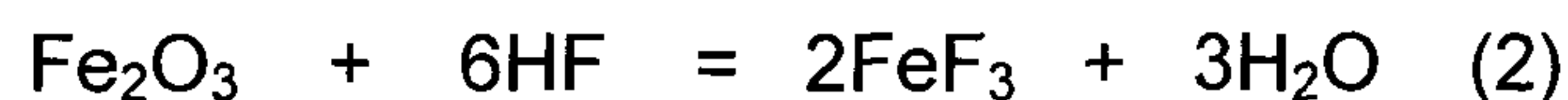

$$160\text{g} + 120 \text{ g} = 226 \text{ g} + 54 \text{ g}$$

The first treatment step takes place in the first reaction tank. Wash solution freshly drawn from a UF_6 cylinder is a mixture of dissolved UO_2F_2 , dissolved contaminant compounds (mostly iron), and 3% – 5% solid sediments (mostly FeF_3). The pH of this mixture is usually 3 – 3.5. The first treatment step is mixing in sufficient NaOH solution to increase the pH to about 5.5 wherein a large part of the soluble contaminants precipitate. Much of the UO_2F_2 will remain in solution at this pH. The 5.5 pH mixture is then pumped into a first settling tank to allow the sediments and precipitates to settle out. The clear liquid portion, which contains nearly all the uranium, is then transferred into a second reaction tank using a conventional floating suction technique that separates a liquid phase from a solid residue or other convenient means for separating liquids from solids.

The settled solids, along with whatever clear liquid is left after the separation, may be slurried using a mixer into a third reaction tank for scavenging, with a $\text{Na}_2\text{CO}_3/\text{NaHCO}_3$ solution, remnant uranium that may have precipitated or is entrained with the sediments. A small amount of NaOH plus the $\text{Na}_2\text{CO}_3/\text{NaHCO}_3$ solution (which

may be recycled from the fluoride removal process of Step 4 below) is added to bring the pH of the solution in the third reaction tank to about 10 where any residual uranium will be converted to soluble carbonate complexes. The sediment and precipitates are then allowed to settle to the bottom of the third reaction tank and the uranium-bearing clear solution is then pumped out, once again using a floating suction technique. This clear solution re-joins the main uranium stream at the carbonate solution storage tank downstream in the process. The remaining sediment solids are then filtered and the filter cake is disposed of as waste.

The initially-separated, clear liquid in the second reaction tank consists is primarily of UO_2F_2 with a small amount of residual HF and a very small remnant of impurities. This solution is treated to separate most of the fluoride content from the uranium by adding enough NaOH solution to bring the mixture to pH 12. This action precipitates the uranium as sodium diuranate (SDU) and leaves fluoride in solution as sodium fluoride. The chemical reactions and stoichiometry are:

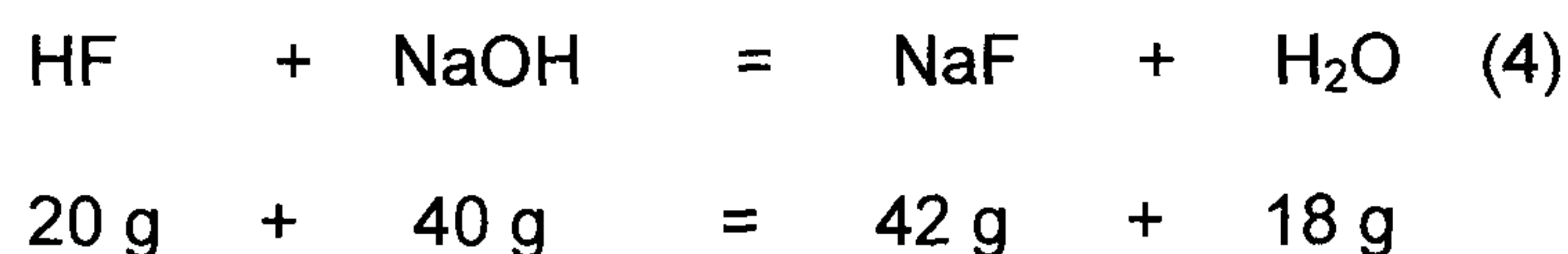
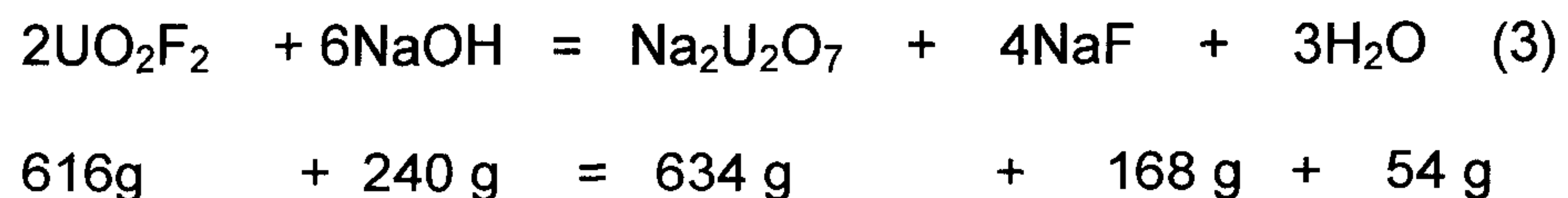

The mixture is stirred to assure the reaction completes before being pumped to a second settling tank, where the SDU is allowed to settle to the bottom of the tank. The clear NaF solution is then separated from SDU using floating suction, or other convenient means, and the separated fluid is passed through polishing cartridge filters 310 to a fourth treatment tank for further processing to remove fluoride.

The remaining SDU precipitate in the second settling tank is slurried with part of the sodium carbonate solution generated from the fluoride removal (described in Step 4 below) and pumped into a fourth reaction tank. There, the mixture is adjusted to pH 10.1 to create the condition where NaHCO_3 is the predominant carbonate species and the SDU precipitate re-dissolves as a uranium carbonate complex. Heating and continued agitation is used to facilitate dissolution. Uranyl carbonate solution, generated from the sediment rinse treatment, is also added to this tank. The chemistry and stoichiometry of this step are:

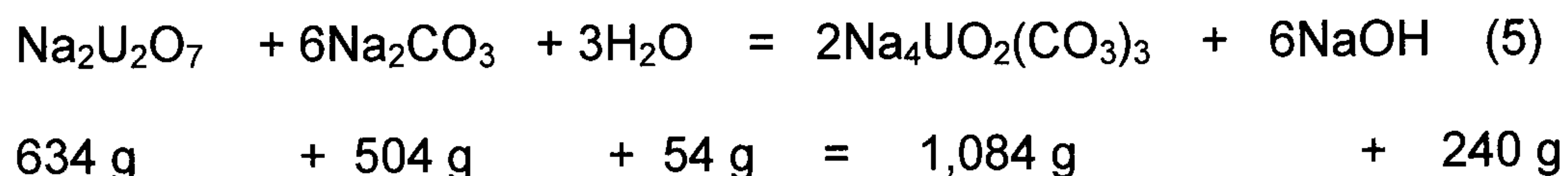

The pH of the NaF solution decanted from the SDU precipitate is adjusted from pH 12 to pH 6.5 – 7.5 by adding 20% nitric acid, heated to about 80 deg C, then percolated through a high-calcium calcite limestone (CaCO_3) bed in the fifth treatment tank 390. The fluoride reacts with the calcium in the calcite to form a calcium fluoride solid which remains in the calcite bed as part of the calcite structure. The reaction also liberates carbonate ion (CO_3) which associates with the sodium left to form a

NaHCO₃/Na₂CO₃ solution mixture as the solution exits the fifth treatment tank. This solution is normally a dischargeable waste, but, within this process, part of it recycles and becomes a reagent for the uranium re-dissolving. The chemistry and stoichiometry of this step are:

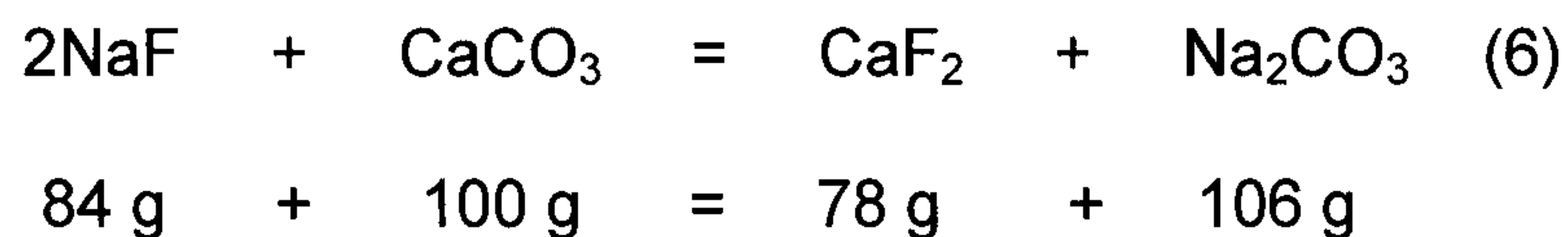

The final step of the process is to recover the uranium as a high-purity uranyl peroxide precipitate. In order to do so, the pH of the reaction mixture for this process needs to be carefully controlled at 4.0 +/- 0.1 for complete uranium recovery. At pH of 2.0 the precipitation reaction stops entirely while, if the pH rises above 4.5, consumption of the precipitation reagent, hydrogen peroxide, increases dramatically. The reaction tank, the sixth reaction tank, for this step can be quite small, about five gallons total volume. Since the main supply of uranyl carbonate complex solution has a pH of about 10, a small amount of nitric acid is added to sixth reaction tank along with a slurry of a small amount of acidified uranyl peroxide seed crystal to initiate the peroxide precipitation reaction. Once the precipitation starts, the reaction will create its own acidification and drive the pH down quickly as the precipitation progresses. The chemistry and stoichiometry of these reactions are:

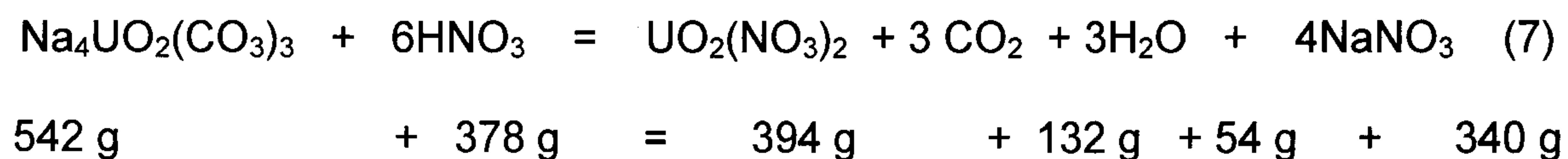

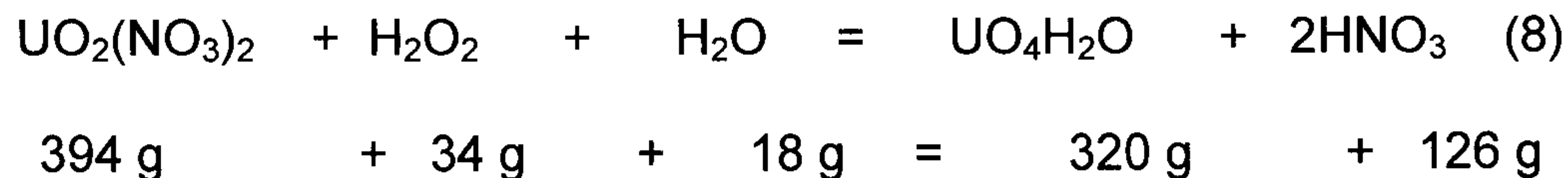

To limit the new acid produced so that a 4.0 pH is maintained, uranyl carbonate solution may be added. With pH control and a metered-in supply of hydrogen peroxide, a continuous, sustained precipitation reaction can be maintained simply by balancing the input flows to keep a steady 4.0 pH condition in sixth reaction tank. The overflow from the sixth reaction tank is routed to an intermediate precipitator tank having a volume of about 30 gallons wherein the precipitation slurry is stirred to promote full precipitation as the reactants are adjusted by small additions if the conditions begin to drift off the target 4.0 pH. Finally, the overflow from the intermediate precipitator tank goes to a large, gently-agitated, digester tank to give several hours of digestion time to complete the precipitation. A small recycle stream from digester tank back to the sixth reaction tank is used to provide the seed crystals to assist initiating the precipitation. Once digester tank is nearly full and given sufficient reaction time, the soluble uranium in it will decrease to about 1 ppm U at which time the stream is drawn off tank through a filter to recover the uranyl peroxide crystals. The filtrate, which is primarily a solution of sodium nitrate, plus excess sodium carbonate generated from the fluoride removal are combined for disposal.

By way of example, the basis for batch material balance calculations is a 5 kg UF₆ heel being washed from a 48Y UF₆ cylinder with 15 gallons (58 liters) of 7% HF wash water.

UO_2F_2 produced (Eq 1): $5,000/352 \times 308 = 4,375$ gm (about 75 gm/l).

HF produced (Eq 1): $5,000/352 \times 80 = 1,136$ gm.

HF in original wash water: $15 \text{ gal} \times 8.42 \text{ lb/gal} \times 0.07 \times 454 \text{ gm/lb} = 4,014$ gm.

Total HF per batch = $1,136 + 4,014 = 5,150$ gm.

Note that a small, indeterminate amount of the HF involved will be consumed by the reaction in the second equation above, but for purposes of material balance, it is ignored.

NaOH needed (Eq 3): $4,375/616 \times 240 = 1,704$ gm.

NaOH needed (Eq 4): $5,150/20 \times 40 = 10,300$ gm.

Total NaOH needed per batch = $1,704 + 10,300 = 12,004$ gm.

If 8M NaOH is supplied (about 25 wt% @ 1,270 gm/l), the amount of NaOH needed is: $12,004/1,270 \times 0.25 = 37.8$ liters or about 10 gallons per batch.

SDU produced (Eq 3): $4,375/616 \times 634 = 4,503$ gm.

For carbonate dissolution of SDU (Eq 5):

Na_2CO_3 is needed (Eq 6): $4,503/634 \times 636 = 4,517$ gm.

Na_2CO_3 generated (Eq 5): $12,008/84 \times 106 = 15,153$ gm.

Therefore, about 30% of the Na_2CO_3 generated from fluoride removal (as described in Step 4) is recycled for SDU dissolution.

$$\text{NaF produced (Eq 3): } 4,375/616 \times 168 = 1,193 \text{ gm.}$$

$$\text{NaF produced (Eq 4): } 5,150/20 \times 40 = 10,815 \text{ gm.}$$

$$\text{Total NaF produced per batch} = 1,193 + 10,815 = 12,008 \text{ gm (about 125 gm/l).}$$

$$\text{Calcite needed for fluoride removal (Eq 6): } 12,008/84 \times 100 = 14,295 \text{ gm.}$$

$$\text{@ 80\% efficiency, calcite needed is: } 14,295/0.8 = 17,869 \text{ gm per batch.}$$

Precipitation of UO_4 from carbonate solution:

$$\text{Na}_4\text{UO}_2(\text{CO}_3) \text{ generated (Eq 6): } 4,503/634 \times 1,084 = 7,699 \text{ gm.}$$

$$\text{HNO}_3 \text{ needed (est) (Eq 7): } 7,699/542 \times 378 = 5,369 \text{ gm.}$$

Note that the HNO_3 requirement is estimated high, since a significant amount is regenerated from the peroxide precipitation itself (see Eq 8) and, with the carbonate addition, helps perpetuate the precipitation via control of the pH.

$$\text{UO}_2(\text{NO}_3)_2 \text{ produced from acidification (Eq 7): } 7,699/542 \times 394 = 5,597 \text{ gm.}$$

$$\text{H}_2\text{O}_2 \text{ needed (Eq 8): } 5,597/394 \times 34 = 483 \text{ gm.}$$

$$\text{@ recommended excess of 40\%, H}_2\text{O}_2 \text{ needed is } 483 \times 1.4 = 676 \text{ gm.}$$

$$\text{If H}_2\text{O}_2 \text{ is supplied as 35 wt\%, the weight of H}_2\text{O}_2 \text{ needed: } 676/0.35 = 1,931 \text{ gm.}$$

@ density of 35% H_2O_2 = 1.14 gm/cc, volume needed is $1,931/1.14 = 1.694$ liters or
 $1.694/3.875 = 0.44$ gallons.

The following is an example of reagent requirements for processing one 48Y UF_6 cylinder through washing and uranium recovery, including the effluents expected. These requirements can be used to estimate different cylinder production rates.

For washing acid preparation, assuming a 49% supply, the HF needed is 8,192 gm. The volume of HF is 6.94 liters (1.79 gallons). In addition, 51.1 liters (13.2 gallons) of new water or water from a previous cylinder rinse are needed.

Wash solution adjustment to pH 5.5 requires approximately 5.8 liters (1.5 gallons) 8M NaOH. Precipitation of SDU at pH 12.0 requires 33 liters (8.5 gallons) 8M NaOH, for a total of 39 liters (10 gallons) 8M NaOH.

Neutralization from pH 12.0 to pH 7.0 of the roughly 93 liters (24 gallons) of NaF solution produced prior to fluoride removal requires about 115 grams of 20% nitric acid. Additionally, initiation of the peroxide precipitation requires an estimated 10% of the stoichiometric amount or about 2,700 grams of 20% nitric acid for a total of about 3 liters (0.8 gallons).

Approximately 17,869 grams or about 18 kg (40 lb) of calcite is required.

Approximately 1,931 (0.5 gallons) of 35 wt% hydrogen peroxide is required.

Process effluent is approximately 100 liters (26 gallons) of liquid containing about 2,530 gm NaNO_3 (25 gm/l) plus 10,635 gm Na_2CO_3 (106 gm/l). Solid waste discharge would be about 14 kg of $\text{CaF}_2/\text{CaCO}_3$ mixture per cylinder plus about 0.5 kg of iron precipitates separated from the wash solution prior to SDU precipitation.

Referring now to Fig. 1, a cylinder 210, such as a 48Y UF₆ cylinders, is not part of the present system but is the work piece for the first portion of the present method. Each cylinder 210 is placed on tilt/roll table, such as the WRU10PT tilt/roll table made by Koike Aronson Ransome Company, or equivalent, and processed through wash and rinse cycles to remove UF₆ heels and interior wall scale developed during cylinder 210's service life. The 7% HF acid wash solution is prepared in a first batch tank 220 and pumped into cylinder 210 for the washing cycle. The liquid from this first washing is pumped into a first reaction tank 230 and rinse water is pumped into cylinder 210. After the rinse cycle is complete, the rinse water is tested for uranium, then brought up to 7% HF strength with added 49% HF to be used as the wash solution for the next cylinder.

After the wash liquid in the first reaction tank 230 is mixed with a small amount (approximately 5.8 liters or 1.5 gallons) of 8M NaOH solution to adjust it to pH 5.5, then it is discharged to a settling tank 240. The mixture settles to an estimated 95% volume clear liquid above 5% volume of sediments and precipitates. Next, settling tank 240 is decanted via a floating suction by a pump that transfers the clear solution into precipitation tank 250. The sediment in settling tank 240 is slurried with 4 liters (1 gallon) water and 2 liters (0.52 gallons) of Na₂CO₃ solution from the fluoride removal process and its contents transferred to a sediment mixing tank 260. The slurry mixture in sediment mixing tank 260 is pH adjusted to pH 10.1 and mixed to convert carry-over uranium into soluble uranyl carbonate. Mixing is then stopped and sediments are allowed to settle. The clear liquid in sediment mixing tank 260 is decanted to uranyl carbonate storage tank 270. The sediments in sediment mixing tank 260 are slurried using another 5 gallons of Na₂CO₃ solution and filtered to remove the solids, which may

be accomplished by using filter press 280. The filtrate is also added to uranyl carbonate storage tank 270. The sediment filter cake may be air-dried and discarded.

The clear UO_2F_2 solution in precipitation tank 250 is precipitated by slowly mixing in enough (est. 25.5 gal) of an 8M NaOH solution to increase the pH to 12.0. The precipitate slurry is mixed for two hours to promote particle size growth, then dumped to a SDU settling tank 290. The slurry settles for a minimum of 12 hours or overnight, perhaps longer if it is slow to settle. The clear liquid from SDU settling tank 290 is decanted through a pump 300 and cartridge filter 310 to a NaF solution storage tank 320. About 22 gallons of Na_2CO_3 solution from the fluoride removal process are mixed in the SDU sediments in SDU settling tank 290 and the pH is adjusted to 10.1, which favors formation of NaHCO_3 . The sediments are mixed for sufficient time to re-dissolve the SDU into soluble carbonates. The carbonate solution is then pumped through a cartridge filter 340 into tank uranyl carbonate storage tank 270. Any un-dissolved sediment caught by cartridge filter 340 is considered an impurity and added to sediment mixing tank 260 for additional Na_2CO_3 treatment and discard.

If uranyl carbonate storage tank 270 is sized to hold plural batches uranyl carbonate solution. It can be set up for peroxide precipitation and uranium recovery in periodic campaigns or on a steady daily operation. The precipitation consists of a three-step operation using three separate tanks. In first precipitation tank 350 all components are vigorously mixed in order to combine them quickly at the start of the precipitation. Flows of uranyl carbonate solution, 20% nitric acid, 35% hydrogen peroxide, and UO_4 seed slurry from a third precipitation tank 360 are all introduced into first precipitation tank 350 in ratios that create a pH of about 2.5 to initiate UO_4 precipitation. Overflow

from first precipitation tank 350 goes into a second precipitation tank 370 where additional uranyl carbonate solution is added to control the pH at about 4.0. Overflow from second precipitation tank 370 goes into third precipitation tank 360 where the mixture is agitated gently for several hours to complete precipitation. After the liquid portion in third precipitation tank 360 falls to 1 ppm U, a side stream of slurry is withdrawn through a filter press 380 to recover the UO_4 crystals. Filtrate from filter press 380 is discarded as a waste stream. The UO_4 crystals recovered from the press are dried and packaged as product.

The NaF solution in NaF solution storage tank 320 is further treated to remove the fluoride by percolating it through a bed of calcite particles contained in calcite bed tank 390. The solution is neutralized to pH 7.0 with 20% nitric acid, heated to about 80 degrees C, and pumped through a distributor pipe 400 at the top of the calcite bed tank 390. As it trickles through the calcite, the fluoride reacts with the calcium in the calcite to form calcium fluoride (CaF_2) solid while the sodium combines with the carbonate ion released to form Na_2CO_3 solution (see Eq 6 above). The CaF_2 forms in such a way as to retain the granular structure and location of the original calcite particles thereby avoiding the need for a filtration separation step. The spent calcite bed is periodically -- perhaps every three months, depending on use -- removed and discarded as the calcite is exhausted then replaced with fresh calcite. The Na_2CO_3 solution is transferred to storage tank 410 for recycle to the SDU dissolution in sediment mixing tank 260 or for effluent waste disposal.

Tanks may be cone-bottomed, full-drain, polyethylene tanks such as those manufactured by U.S. Plastics for most of the process tanks and a stainless steel tank

for calcite bed tank 390 because of their low cost and chemical resistance. Double-diaphragm air-driven pumps and industrial propeller blade mixers are suitable for the present system.

In an embodiment of the present invention, a facility would be established for washing empty uranium hexafluoride shipping containers and recovery of the uranium that results from removal of the heel in those containers. The process is inherently a batch process as each cylinder is washed one at a time, although parallel wash lines can be established. Washed cylinders are forwarded to sources of uranium hexafluoride for refilling.

The scope of the claims should not be limited by the preferred embodiments set forth in the examples, but should be given the broadest interpretation consistent with the description as a whole.

#1366363

WHAT IS CLAIMED IS:

1. A process for recovering residual uranium from an empty uranium hexafluoride shipping container during cleaning, said process comprising the steps of:
 - (a) rinsing the interior of a uranium hexafluoride shipping container with hydrofluoric acid in order to clean the interior wall of the container and to dissolve a heel of uranium hexafluoride therein and form a uranium solution;
 - (b) obtaining said uranium solution from said container;
 - (c) mixing sodium hydroxide with said uranium solution from said container for precipitating sodium diuranate from said solution while also forming sodium fluoride;
 - (d) dissolving said sodium diuranate in a solution that contains carbonate to form a uranium carbonate complex;
 - (e) separating sodium fluoride from said uranium solution; and
 - (f) precipitating uranyl peroxide from said uranium carbonate complex.

2. The process as recited in claim 1, further comprising the step of weighing said shipping container to determine the mass of said heel of uranium hexafluoride.

3. The process as recited in claim 2, further comprising the step of determining the quantity of hydrofluoric acid needed to dissolve said mass of said heel of said uranium hexafluoride heel.

4. The process as recited in claim 1, wherein said rinsing step further comprises the step of using 7% hydrofluoric acid to rinse said shipping container.

5. The process as recited in claim 1, wherein said rinsing step further comprises the step of contacting all interior surfaces of said shipping container by rolling said shipping container while tilting said shipping container.

6. The process as recited in claim 1, further comprising the steps of
(g) rinsing said shipping container with water after said hydrofluoric acid rinsing step; and

(h) then sampling the uranium concentration of said water to verify said uranium concentration of said water is less than 3000 ppm.

7. The process of claim 1, wherein said dissolving step further comprises the steps of slurring of said sodium diuranate with a sodium carbonate solution to form a mixture, and adjusting pH of said mixture to re-dissolve said sodium diuranate in the carbonate solution as uranium carbonate complexes.

8. The process of claim 1, further comprising the step of adjusting pH of said sodium fluoride solution to 7.0 before percolating said solution through a calcite limestone bed to form calcium fluoride for removal from the solution.

9. The process recited in claim 1, further comprising the step of adjusting the pH of said uranium carbonate complex to about 4.0 to precipitate uranyl peroxide.

10. The process recited in claim 9 further comprising the step of controlling the pH of 4.0 to within 0.1 by adding uranyl carbonate solution.

11. A process for recovering residual uranium from empty uranium hexafluoride shipping cylinder during cleaning, said process comprising the steps of:

(a) rinsing the interior of a uranium hexafluoride shipping cylinder with 7% hydrofluoric acid in order to dissolve a heel of uranium hexafluoride therein and form a mixture of sediment, precipitates and a uranium solution;

(b) separating said uranium solution from said sediment and said precipitates;

(c) mixing sodium hydroxide with said separated uranium solution to form a slurry of sodium diuranate solids in sodium fluoride solution;

(d) separating said sodium fluoride solution from said sodium diuranate solids;

(e) reacting sodium fluoride from said separated sodium fluoride solution with calcium carbonate to form calcium fluoride while liberating carbonate ions which associate with sodium to form a solution of sodium carbonates;

(f) dissolving said sodium diuranate solids in a solution that contains carbonate to form a solution of uranium carbonate complexes;

(g) adjusting the pH of said solution of uranium carbonate complexes to about 4.0 to precipitate uranyl peroxide from said solution; and

(h) maintaining said pH at about 4.0.

12. A process for recovering residual uranium from empty uranium hexafluoride shipping cylinders during cleaning, said process comprising the steps of:

(a) collecting plural empty uranium hexafluoride cylinders;

(b) weighing each cylinder of said plural cylinders to determine the mass of a heel of uranium hexafluoride contained by said each cylinder;

(c) adding hydrofluoric acid to said each cylinder;

(d) exposing the interior of said each cylinder to said hydrofluoric acid to dissolve said heel and form a uranium solution;

(e) emptying said uranium solution from each cylinder into a tank;

(f) rinsing said each cylinder with water;

- (g) determining a uranium concentration of said water;
- (h) re-rinsing said each cylinder with water if said uranium concentration exceeds 3000 ppm; and
- (i) processing contents of said tank to recover said uranium.

13. The process as recited in claim 12, wherein said hydrofluoric acid is a 7% hydrofluoric acid solution.

14. The process as recited in claim 12, further comprising the step of forwarding said plural cylinders wherein said concentration of uranium is less than 3000 ppm to a facility for refilling with uranium hexafluoride.

15. The process as recited in claim 13, wherein said processing step further comprises the steps of:

- (j) separating sediment and precipitates from said uranium solution;
- (k) mixing sodium hydroxide with said uranium solution to precipitate sodium diuranate;
- (l) dissolving said sodium diuranate in a solution that contains carbonate to form a solution of uranium carbonate complexes; and
- (m) precipitating uranyl peroxide from said solution.

16. The process as recited in claim 15, wherein said precipitating step further comprises the steps of:
- (n) adjusting the pH of said solution to about 4.0 to precipitate uranyl peroxide from said solution; and
 - (o) maintaining said pH at about 4.0.
17. The process as recited in claim 1, wherein the rinsing of the interior of the container with hydrofluoric acid forms a mixture of sediment, precipitates and a uranium solution.
18. The process as recited in claim 17 which further comprises:
- (p) separating the uranium solution from said sediment and said precipitates.
19. A process for recovering residual uranium from an empty uranium hexafluoride shipping container during cleaning, said process comprising the steps of:
- rinsing the interior of a uranium hexafluoride shipping container with a solution of hydrofluoric acid in order to clean the interior wall of the container and to dissolve a heel of uranium hexafluoride therein and form a uranium solution sediment and precipitates;
 - a treatment step of adding sodium hydroxide to the uranium solution so as to precipitate contaminants while leaving uranium in solution;

a separation step so as to remove the contaminant-containing precipitates from the uranium containing solution;

a precipitation step wherein sodium hydroxide is added to the uranium-containing solution to precipitate sodium diuranate while leaving sodium fluoride in solution;

a separation step so as to remove sodium fluoride from the sodium diuranate;

a reaction step of forming uranyl carbonate by combining the sodium diuranate with sodium carbonate solution; and

forming uranyl peroxide by the addition of nitric acid and hydrogen peroxide to the uranyl carbonate solution wherein the pH is controlled at a value of 4.0 ± 0.1 .

#1366351

