

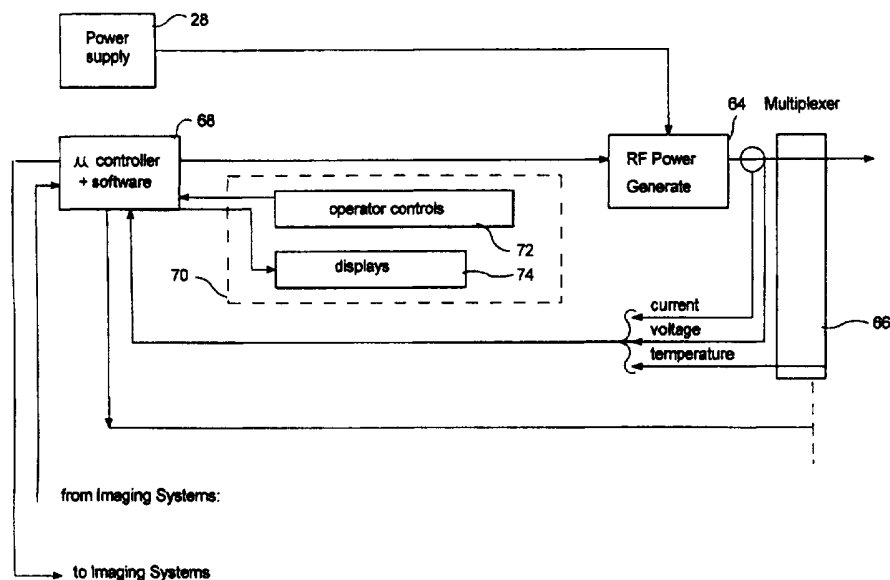

## INTERNATIONAL APPLICATION PUBLISHED UNDER THE PATENT COOPERATION TREATY (PCT)

<p>(51) International Patent Classification <sup>6</sup> : <b>A61B 17/38, 17/36</b></p>	<p><b>A1</b></p>	<p>(11) International Publication Number: <b>WO 97/24992</b></p> <p>(43) International Publication Date: 17 July 1997 (17.07.97)</p>
<p>(21) International Application Number: PCT/US97/00162</p> <p>(22) International Filing Date: 2 January 1997 (02.01.97)</p> <p>(30) Priority Data: 08/583,815                      5 January 1996 (05.01.96)                      US</p> <p>(71)(72) Applicant and Inventor: KNOWLTON, Edward, W. [US/US]; 5478 Blackhawk Drive, Danville, CA 94506 (US).</p> <p>(74) Agent: DAVIS, Paul; Wilson Sonsini Goodrich &amp; Rosati, 650 Page Mill Road, Palo Alto, CA 94304-1050 (US).</p>		<p>(81) Designated States: AL, AM, AT, AU, AZ, BA, BB, BG, BR, BY, CA, CH, CN, CU, CZ, DE, DK, EE, ES, FI, GB, GE, HU, IL, IS, JP, KE, KG, KP, KR, KZ, LC, LK, LR, LS, LT, LU, LV, MD, MG, MK, MN, MW, MX, NO, NZ, PL, PT, RO, RU, SD, SE, SG, SI, SK, TJ, TM, TR, TT, UA, UG, UZ, VN, ARIPO patent (KE, LS, MW, SD, SZ, UG), Eurasian patent (AM, AZ, BY, KG, KZ, MD, RU, TJ, TM), European patent (AT, BE, CH, DE, DK, ES, FI, FR, GB, GR, IE, IT, LU, MC, NL, PT, SE), OAPI patent (BF, BJ, CF, CG, CI, CM, GA, GN, ML, MR, NE, SN, TD, TG).</p> <p><b>Published</b> <i>With international search report.</i></p>

(54) Title: METHOD FOR SCAR COLLAGEN FORMATION AND CONTRACTION



## (57) Abstract

A method is disclosed for forming and contracting scar collagen below a tissue surface in a selected tissue site. An electromagnetic energy apparatus is provided and includes an electromagnetic energy source and a delivery device. The delivery device is positioned on the tissue surface. Electromagnetic energy is produced from the electromagnetic energy source and delivered through the tissue surface to the selected tissue site for a sufficient time to induce scar collagen formation in the selected tissue site. No more than a second degree burn is formed on the tissue surface. The scar collagen is then contracted. This method is particularly useful in tissue sites that are devoid or deficient in collagen.

**FOR THE PURPOSES OF INFORMATION ONLY**

Codes used to identify States party to the PCT on the front pages of pamphlets publishing international applications under the PCT.

AM	Armenia	GB	United Kingdom	MW	Malawi
AT	Austria	GE	Georgia	MX	Mexico
AU	Australia	GN	Guinea	NE	Niger
BB	Barbados	GR	Greece	NL	Netherlands
BE	Belgium	HU	Hungary	NO	Norway
BF	Burkina Faso	IE	Ireland	NZ	New Zealand
BG	Bulgaria	IT	Italy	PL	Poland
BJ	Benin	JP	Japan	PT	Portugal
BR	Brazil	KE	Kenya	RO	Romania
BY	Belarus	KG	Kyrgystan	RU	Russian Federation
CA	Canada	KP	Democratic People's Republic of Korea	SD	Sudan
CF	Central African Republic	KR	Republic of Korea	SE	Sweden
CG	Congo	KZ	Kazakhstan	SG	Singapore
CH	Switzerland	LI	Liechtenstein	SI	Slovenia
CI	Côte d'Ivoire	LK	Sri Lanka	SK	Slovakia
CM	Cameroon	LR	Liberia	SN	Senegal
CN	China	LT	Lithuania	SZ	Swaziland
CS	Czechoslovakia	LU	Luxembourg	TD	Chad
CZ	Czech Republic	LV	Latvia	TG	Togo
DE	Germany	MC	Monaco	TJ	Tajikistan
DK	Denmark	MD	Republic of Moldova	TT	Trinidad and Tobago
EE	Estonia	MG	Madagascar	UA	Ukraine
ES	Spain	ML	Mali	UG	Uganda
FI	Finland	MN	Mongolia	US	United States of America
FR	France	MR	Mauritania	UZ	Uzbekistan
GA	Gabon			VN	Viet Nam

## **METHOD FOR SCAR COLLAGEN FORMATION AND CONTRACTION**

### **Cross-Reference to Related Cases**

5 The present application is a continuation-on-part of U.S. Patent Application Serial No. 08/435,822, filed May 5, 1995, entitled "Method and Apparatus for Controlled Contraction of Collagen Tissue", having the same named inventor Edward W. Knowlton, incorporated herein by reference.

### **BACKGROUND OF THE INVENTION**

#### **Field of the Invention**

10 This invention relates generally to a method for creating scar collagen, and more particularly to a method for initiating the formation and healing of scar collagen or bony callus, and subsequently remodeling the scar collagen or bony callus.

#### **Description of Related Art**

15 The skin is composed of two basic elements, the epidermis and the underlying dermis. The underlying dermis provides the main structural support of the skin. The epidermis contains the epithelial cells and pigment forming cells called melanocytes. The dermis varies in thickness throughout the body. For instance, the skin is 25 times thicker on the back than on the eyelid.

20 The dermis is composed mainly of an extracellular protein called collagen. Collagen exists as a triple helix with three polypeptide chains that are connected with heat labile and heat stable chemical bonds. When collagen is heated, alterations in the physical properties of this protein occur at a characteristic temperature. This structural transition occurs at a specific shrinkage temperature.

25

The phenomenon of thermal shrinkage of collagen begins with a denaturization of the triple helix of the collagen molecule. Thermal energy severs the heat labile bonds that stabilize the triple stranded helix. As a result,

the longitudinal axis of the molecule contracts. Partial denaturation of collagen tissue occurs in second degree burns and is typically applied as a standard thermal gradient that is hotter on the surface and cooler in the underlying dermis. In burn patients, partial denaturation of dermal collagen provides a tightening effect on the skin. By applying a reverse thermal gradient which cools the surface of the skin while heating the underlying collagen-containing layers, contraction of collagen in the absence of a second degree burn (and its inherent blistering and pigmentary irregularities) is possible. Because collagen is found in tendon, bone, cartilage and all other connective tissue throughout the body, reverse thermal gradient contraction of collagen can have many applications.

The selective induction of the basic wound healing process serves as the basis for the second major application of thermal shrinkage of collagen. In higher developed animal species, the wound healing response to injury involves an initial inflammatory process that subsequently leads to the deposition of scar tissue. The initial inflammatory response consists of the infiltration by white blood cells or leukocytes that dispose of cellular debris. Forty-eight hours later, proliferation of fibroblasts at the injured site occurs. These cells then produce scar collagen that functions as the main support structure of a healed wound. The deposition and subsequent remodeling of this nascent scar collagen provides the means to alter the consistency and geometry of soft tissue for both aesthetic and reconstructive purposes.

There exists an aesthetic need to contract skin without the scars, surgical risks or pigmentary side effects of commonly employed technique. These techniques include surgical resection of skin and the use of lasers and chemical peels to achieve a tighter, more youthful skin appearance. Understandably, many patients are hesitant to subject themselves to these procedures, even though an overall aesthetic improvement is likely.

Skin resection procedures are limited in their application due to inherent scars. With face-lift procedures, scars can be hidden around the contour of the ear, thus providing an acceptable trade-off between the surgical scar and the aesthetic improvement. Surgical resection of skin on the hips, thighs, arms,

knees and legs, however, provides only a modest improvement with fairly unsightly scarring. In addition, patients must undergo a post-operative phase of healing that may be both painful and inconvenient. Other risk factors, such as bleeding and infection, may prolong healing.

5           Liposuction is effective at removing fat in some areas, however, it does not tighten the skin envelope. Skin resurfacing techniques that secondarily tighten excess skin (such as laser and chemical peels) employ a standard thermal gradient that requires burning off the superficial skin as a second degree burn. The thermal effects of collagen contraction in the deeper dermis occur, but  
10           require a painful healing phase due to the second degree burn. These modalities depend upon reepithelialization with cell migration from the skin appendages. This process of reepithelialization is similar to the healing of any thermal burn and is more likely to cause pigmentary irregularities due to the destruction of melanocytes in the epidermis.

15           Adipose tissue, more commonly known as fat, is formed of cells containing stored lipid. Adipose tissue is often subdivided into small loculations by connective collagen tissue serving as the fibrous septae.

          There exists a need for subcutaneously contracting of collagen without surgical scarring or pigmentary side effects of more invasive techniques. There  
20           is a further need for subcutaneously inducing the formation and contraction of scar collagen in a selected tissue site while creating no deeper than a second degree burn on the surface of the selected tissue site.

#### SUMMARY OF THE INVENTION

          It is an object of the present invention to provide a method for thermal  
25           remodeling and contraction of collagen without surgical scarring or pigmentary side effects.

          Another object of the present invention is to provide a method for inducing the formation and contraction of scar collagen.

A further object of the present invention is to provide a method for inducing the formation and contraction of scar collagen in a selected tissue site while creating no deeper than a second degree burn on the surface of the selected tissue site.

5 Yet another object of the present invention is to provide a method for inducing the formation and contraction of bony callus in periosteum tissue.

Still a further object of the present invention is to provide a method for contracting collagen tissue no deeper than a second degree burn formed on a tissue surface overlying the contracted collagen tissue, and preferably no deeper  
10 than a first degree burn.

These and other objects of the invention are provided in a method for forming and contracting scar collagen below a tissue surface in a selected tissue site. An electromagnetic energy apparatus is provided and includes an electromagnetic energy source and a delivery device. The delivery device is  
15 positioned on the tissue surface. Electromagnetic energy is produced from the electromagnetic energy source and delivered through the tissue surface to the selected tissue site for a sufficient time to induce scar collagen formation in the selected tissue site. No deeper than a second degree burn is formed on the tissue surface. The scar collagen is then contracted. This method is particularly useful  
20 in soft tissue sites that are devoid or deficient in collagen.

In another embodiment, a method is disclosed for forming callus deposition in a selected periosteum tissue site. An electromagnetic energy apparatus is provided and includes an electromagnetic energy source and a delivery device. The delivery device is positioned on a tissue surface of the  
25 selected periosteum tissue site. Electromagnetic energy is produced from the electromagnetic energy source. Electromagnetic energy is transcutaneously delivered from the delivery device, through the tissue surface, and to the selected periosteum tissue site for a sufficient time to induce callus formation in the selected periosteum tissue site. After scar collagen formation the callus is then  
30 contracted.

Suitable applications for the methods of the present invention include but are not limited to, tightening and firming soft tissue, unstable joints due to collateral ligament laxity, the treatment of unstable spinal column disorders, treatment of weaknesses of the abdominal wall, treatment of other connective  
5 tissues, esophageal hernia with reflux, urinary incontinence in women, dysdynamic segments of the myocardium and other aneurysmal dilatations of the vessel, sleep apnea, laxity and wrinkling of the skin, and the like.

Wrinkling of the skin occurs as a consequence of inadequate support of the epidermis. The induction of scar collagen deposition is used for the  
10 treatment of wrinkles. Improved skin turgor is accomplished by first replenishing the collagen matrix that has been lost with aging. Following the deposition of nascent scar collagen in the dermis, contraction of collagen with a reverse thermal gradient corrects wrinkling of the skin without resorting to resurfacing techniques that require the application of a standard thermal gradient  
15 burn to the skin. This is achieved without undergoing a lengthy post-operative healing process. Bleeding and infection is reduced. Second degree burns to the superficial skin are minimized. The melanocytes are not damaged and pigmentary irregularities are avoided.

One apparatus used to create the reverse thermal gradient is a combined  
20 heating pad that has both cooling elements and electromagnetic delivery devices. The heating pad is configured to the topography of the treatment area and is incorporated into an elastic garment. Partial denaturization of collagen with contraction of skin is achieved with each treatment. Thermal transducers measure the surface temperature of the treatment area to avoid blistering. In one  
25 embodiment the deeper dermis is heated to above 65 degrees for collagen contraction. The temperature can vary depending on local tissue factors. Sequential treatments are designed to allow for more precision of the end result. Areas of application are not confined by requirements to either hide surgical incisions or transition along aesthetic boundaries.

30 Because scarring and pigmentary irregularities are avoided, skin or other tightening occurs in areas previously considered "off-limits" to standard methods

of surgical resection, laser and chemical resurfacing. Skin tightening with a reverse thermal gradient contraction of collagen can correct areas including but not limited to the thighs, knees, arms, back and hips without unsightly scarring of standard techniques. In addition, areas previously corrected by aesthetic  
5 procedures, such as face and neck lifts, can be corrected without requiring surgery or the typical incisions around the ear. Elastosis or stretching of the abdominal skin from pregnancy can be corrected without the extensive incision of an abdominoplasty. The method of the present invention can also be used for mastopexies or breast uplifts.

10 The fibrous septae in subcutaneous fat layers can be contracted to tighten the soft tissue. Along with the extracellular effects of collagen, intracellular effects upon the fat cell, or lipocyte, by thermal induction cause a net reduction of fat in the lipocyte which achieves a net reduction in volume of the treated area. A second thermal device is used in tandem with the initial thermal device  
15 to achieve liposculpture of the treated area. The second device can be designed with a convergent lens that is focused at the appropriate level on the subcutaneous tissue.

A variety of electromagnetic energy sources can be employed. Suitable energy sources include but are not limited to RF, microwave, ultrasound and the  
20 like. In one embodiment, the preferred energy source is RF.

#### BRIEF DESCRIPTION OF THE FIGURES

Fig. 1 is a perspective view of an apparatus for applying electromagnetic energy through the skin in order to cause a partial denaturization of collagen tissue, resulting in a tightening of the skin.

25 Figure 2 is a cross-sectional view of the skin and underlying tissue.

Figure 3 is a schematic representation of the collagen network.

Fig. 4 is a schematic diagram of an apparatus for applying electromagnetic energy to underlying subcutaneous layers or deeper soft tissue layers to create a desired contour effect by partially denaturing collagen tissue,



and without substantially modifying melanocytes and other epithelial cells in the epidermis.

Figure 5 is a block diagram of an RF system which can be utilized with the present invention.

5 Figure 6 is a block diagram of processing circuit of one embodiment of the invention.

### DETAILED DESCRIPTION

For purposes of this specification, the following definitions apply.

10 Pre-existing collagen is the protein substance normally present in the white fibers (collagenous fibers) of skin, tendon, bone cartilage and all other connective tissue.

Thermal induction of scar collagen deposition is a non-ablative neosynthetic process of collagen deposition as a reaction to inflammation induced by thermal injury. The resulting scar collagen is frequently referred to as nascent, as opposed to pre-existing.

15 Standard thermal gradient is the thermal content of tissue that is greater on the skin surface.

Reverse thermal gradient is, (i) the application of electromagnetic energy to alter the biophysical properties of collagen, i.e., contraction, with minimal blistering of the tissue surface, (ii) a gradient in which the tissue surface temperature is cooler than the underlying collagen tissue, (iii) conditions in which a standard thermal gradient is reduced or equalized in temperature between the tissue surface and the underlying collagen, or (iv) monitoring the heat content (temperature and exposure duration) of the tissue surface to avoid blistering during treatment, regardless of the tissue surface temperature relative to the underlying collagen tissue.

25 Transcutaneously means that the delivery device delivers electromagnetic energy directly through the tissue surface.

30 Percutaneously means that the delivery device is inserted through the skin or the tissue surface through an endoscope, arthroscope, and the like.

Transmucosal means that the delivery device delivers electromagnetic energy directly through the mucosal surface.

Permucosal means that a delivery device is inserted through a mucosal surface through an endoscope, arthroscope, and the like.

5 A first degree burn means a burn that involves only the epidermis. It is characterized by erythema.

A second degree burn means a burn that destroys the epithelium and a variable portion of the dermis.

10 A third degree burn means a burn that destroys the entire thickness of skin, including the epithelium and dermis.

The present invention provides a method for forming and contracting scar collagen below a tissue surface in a selected tissue site. The formation or induction of scar collagen formation can be done transcutaneously, with a reverse thermal gradient, percutaneously, transmucosally, permucosally, or  
15 through a device including but not limited to an endoscope. An electromagnetic energy apparatus is provided and includes an electromagnetic energy source and a delivery device. The delivery device is positioned on the tissue surface. Electromagnetic energy is produced from the electromagnetic energy source and delivered through the tissue surface to the selected tissue site for a sufficient time  
20 to induce scar collagen formation in the selected tissue site. No deeper than a second degree burn is formed on the tissue surface. The scar collagen is subsequently contracted. This method is particularly useful in soft tissue sites that are devoid or deficient in collagen.

In another embodiment, a method is disclosed for forming callus  
25 deposition in a selected periosteum tissue site. An electromagnetic energy apparatus is provided and includes an electromagnetic energy source and a delivery device. The delivery device is positioned on a tissue surface of the selected periosteum tissue site. Electromagnetic energy is produced from the electromagnetic energy source. Electromagnetic energy is delivered from the  
30 delivery device, through the tissue surface, and to the selected periosteum tissue site for a sufficient time to induce callus formation in the selected periosteum

tissue site. The callus is subsequently contracted. The method for forming callus can be done transcutaneously, with a reverse thermal gradient, percutaneously, transmucosally permucosally, or through a device including but not limited to an endoscope.

5           The methods of the present invention use an electromagnetic energy source to apply electromagnetic energy to a selected tissue site. The electromagnetic energy can be delivered transcutaneously, with a reverse thermal gradient, percutaneously, transmucosally, permucosally, or through a device including but not limited to an endoscope. The electromagnetic energy  
10 induces scar collagen formation in tissue sites that, (i) have pre-existing collagen, (ii) are deficient in pre-existing collagen, or (iii) lack pre-existing collagen. Following the formation of the scar collagen, the application of electromagnetic energy contracts the scar collagen.

          Additionally, the methods of the present invention provide for the  
15 contraction of collagen tissue underlying a tissue surface area. The overlying layer of tissue is not ablated. No deeper than a second degree burn is produced in the overlying layer of tissue, and preferably no deeper than a first degree burn.

          Suitable applications for the methods of the present invention include but are not limited to, tightening and firming soft tissue, treatment of unstable joints  
20 due to collateral ligament laxity, the treatment of unstable spinal column disorders, treatment of weaknesses of the abdominal wall, treatment of other connective tissues, esophageal hernia with reflux, urinary incontinence in women, dysdynamic segments of the myocardium and other aneurysmal dilatations of the vessels, sleep apnea, laxity and wrinkling of the skin, and the  
25 like.

          Laxity and wrinkling of the skin occurs as a consequence of inadequate support of the epidermis. The induction of scar collagen deposition is used for the treatment of wrinkles. Improved skin turgor is accomplished by first  
30 replenishing the collagen matrix that has been lost with aging. Following the deposition of nascent scar collagen in the dermis, contraction of collagen with a reverse thermal gradient corrects the laxity and wrinkling of the skin without

resorting to resurfacing techniques that require the application of a standard thermal gradient burn to the skin. This is achieved without undergoing a lengthy post-operative healing process. Bleeding and infection are reduced. Second degree burns to the superficial skin are minimized. The melanocytes are not damaged and pigmentary irregularities are avoided.

In one embodiment, skin tightening with a reverse thermal gradient contraction of collagen corrects areas such as the thighs, knees, arms, back, face and neck lifts, and hips without unsightly scarring. Elastosis, or stretching of the abdominal skin from pregnancy is corrected without the long scar commonly associated with an abdominoplasty. Breast uplifts, i.e., mastopexies, no longer require extensive incisions.

Thermal remodeling of collagen can occur with both native (dermal) collagen and collagen produced as part of the healing process. Wound healing involves an initial inflammatory stage that is followed by a period of rapid nascent collagen production that morphologically appears as a scar. The biophysical properties of collagen are the same regardless of its origin.

One apparatus used to create the reverse thermal gradient is a composite heating pad that has both cooling elements and electromagnetic delivery devices. The heating pad is configured to the topography of the treatment area and is incorporated into an elastic garment. Partial denaturation of collagen is achieved with each treatment. Thermal transducers measure the surface temperature of the treatment area to avoid blistering. In one embodiment the deeper dermis is heated to above 65 degrees for collagen contraction. Sequential treatments are designed to allow for more precision of the end result. Areas of application are not confined by requirements to either hide surgical incisions or transition along aesthetic boundaries.

Various types of electromagnetic energy can be utilized with the present invention. Electromagnetic energy may be any kind that can cause cell heating or physical destruction by being applied to collagen tissue. Examples of suitable electromagnetic energy sources include, but are not limited to RF, microwave, ultrasound, laser and the like.

Referring now to Fig. 1, an apparatus 10 applies electromagnetic energy through a skin layer 12, such as the epidermis, and to the underlying collagen tissue 14 without substantially modifying melanocytes and other epithelial cells 16 found in the lower layer of epidermis layer 12.

5 A porous membrane 18 is adapted to receive an electrolytic solution 20. Porous membrane 18 becomes inflated to substantially conform a contacting exterior surface 22 of porous membrane 18 which is in close thermal contact with epidermis 12. Porous membrane 18 includes a cooling lumen 24 for receiving a cooling fluid that imparts a cooling effect on epidermis layer 12.

10 One or more electromagnetic electrodes 26 are positioned at various places in porous membrane 18. In one embodiment, electromagnetic electrodes 26 are positioned on a side that is substantially opposing to contacting exterior surface 22. In other embodiments, electromagnetic electrodes 26 are placed closer to cooling lumen 24. In embodiment particularly suitable for the hips,  
15 porous membrane is about 20 cm by 30 cm, with an oval shape.

An electromagnetic power source 28 is coupled to electromagnetic electrodes 26 and a source of electrolytic solution 30 is coupled to porous membrane 18.

20 In one method of the present invention, collagen tissue in a dermis underlying the epidermis of the skin is transcutaneously contracted with the use of a thermal heating apparatus. Electromagnetic energy is transcutaneously delivered through the epidermis to the underlying dermis. Fibroblast proliferation is initiated in the underlying dermis. Scar collagen is formed in the underlying dermis. The scar collagen is subsequently contracted and the skin is  
25 tightened.

In another embodiment, a method is provided for contracting collagen tissue in a subcutaneous fat layer through an overlying epidermis layer. A thermal heating apparatus produces electromagnetic energy. The electromagnetic energy can be delivered transcutaneously, with a reverse  
30 thermal gradient, percutaneously, transmucosally permucosally, or through a device including but not limited to an endoscope. The electromagnetic energy is

directed through the epidermis to the underlying subcutaneous fat layer. Fibroblast proliferation is initiated in the subcutaneous fat layer. Scar collagen is formed and then tightened.

5 With referenced now to Fig. 2, electromagnetic energy can be applied through epidermis layer 12, to papillary dermis layer 32, to reticular dermis layer 34, to subcutaneous layer 35, as well as to underlying soft tissue 36. The extent of collagen in the various layers is < 5% in the epidermis, ~ 50% in the dermis, ~ 20 % in the subcutaneous, ~ 10% in the muscle with overlying fascia. Shrinking of collagen tissue takes place in a direction parallel to the axis of the collagen  
10 fibers. Thermal shrinkage of collagen begins with the denaturation of the triple helix structure of the collagen fibers. This occurs when electromagnetic energy is applied to the collagen tissue causing the hydrolysis of heat labile cross links of the collagen network.

Fig. 3 is a schematic representation of a collagen network behavior under  
15 the influence of heat. The thickened lines represent the chains originally bound by covalent cross links. The arrows indicate tensions exerted on the collagen chains by the effect of heat. More particularly, Fig. 3 illustrates (i). native collagen network 40, (ii). collagen 42 under isometric conditions, (iii). collagen network without any restraint, (iv). collagen network 46 under isometric  
20 tension as long as the nodes are stable, and (v). collagen network 48 under isometric tension after some cross links have been cleaved.

Electromagnetic electrodes 26 can be RF electrodes comprising a single electrode, or a plurality which can form a segmented flexible circuit. Electromagnetic power source 28 is then an RF generator. Electrolytic solution  
25 20 is introduced into porous membrane 18 and passes by RF electrodes 26. Electrolytic solution 20 transfers RF power from RF electrodes 28 to the desired underlying collagen tissue to achieve partial denaturation of the collagen molecule.

Generally, RF electrodes 26 can be monopolar or bipolar. In the  
30 monopolar mode, RF current flows through body tissue from a return electrode

which can be in a form of a conductive pad applied to the patients outer skin. Maximum heating occurs where the current density is the greatest.

During a treatment phase, the denaturization of collagen molecules can be conducted under feedback control. Treatment can occur without the  
5 attention of medical supervision. Feedback is accomplished by (i). visualization, (ii). impedance, (iii). ultrasound, or (iv). temperature measurement. Optionally included and preferably positioned on contacting exterior surface 22 can be one or more thermal sensors 52, as well as one or more impedance monitors 54. Thermal sensors 52 permit accurate determination of the surface temperature of  
10 epidermis layer 12.

Electrolytic solution 20 can be preheated to a selected temperature and modified as necessary. This reduces the amount of time needed to effect at satisfactory denaturization of collagen molecules and subsequent skin tightening.

Porous membrane 18 can be made of a material that is an insulator. For  
15 purposes of this disclosures, an insulator is a barrier to thermal or electrical energy flow. Porous membrane 18 can be made of a material which permits controlled delivery of electrolytic solution 20 to epidermis layer 12. Porous membrane 18 can be made of a variety of materials including, but not limited to knitted polyester, continuous filament polyester, polyester-cellulose, rayon,  
20 polyamide, polyurethane, polyethylene and the like. Suitable commercial products include, (i). Opcell available from Centinal Products Corp., Hyannis, Mass, and (ii). UltraSorb, HC 4201 or HT 4644 MD from Wilshire Contamination Control, Carlsbad, California. Pockets or zones 56 can be formed around RF electrodes 26. Each pocket 56 has a lower porosity for the  
25 flow of electrolytic solution 20 than all other sections of porous membrane 18. Differences in porosity can be achieved with different types of materials which form porous membrane 18. Electrolytic solution 20 is retained in pockets 56 longer than in non-pocket sections of porous membrane 18, and there is a greater transfer of RF energy to electrolytic solution 20, creating a larger  
30 electrode. The larger electrode produces RF and thermal energy to create a

larger electrode effect. However, this does not effect the creation of the reverse thermal gradient. RF energy is still transferred through porous membrane 18 passing in the vicinity of cooling lumen 24, in order to create a lower temperature at epidermis layer 12 and the temperature increases as deeper layers are reached.

In a skin contracting method of the present invention, a tighter, more youthful skin envelope is achieved. This is accomplished without undergoing a lengthy post-operative healing process. Bleeding and infection is reduced. Second degree burns to the superficial skin are minimized. The melanocytes are not damaged and pigmentary irregularities are avoided.

Because scarring and pigmentary irregularities are avoided, skin or other tightening occurs in areas previously considered "off-limits" to standard methods of surgical resection, laser and chemical resurfacing. Skin tightening with a reverse thermal gradient contraction of collagen can correct areas including but not limited to the thighs, knees, arms, back and hips without unsightly scarring of standard techniques. In addition, areas previously corrected by aesthetic procedures, such as face and neck lifts, can be corrected without requiring surgery or the typical incisions around the ear. Elastosis or stretching of the abdominal skin from pregnancy can be corrected without the extensive incision of an abdominoplasty. The method of the present invention can also be used for mastopexies or breast uplifts..

The fibrous septae in subcutaneous fat layers can be contracted to tighten the soft tissue. Along with these extracellular effects of collagen, intracellular thermal induction effects upon the fat cell or lipocyte results in a net egress of fat from the lipocyte which achieves a net reduction of volume of the treated area. A second thermal device is used in tandem with the initial thermal device to achieve liposculpture of the treated area. The second device can be designed with a convergent lens that is focused at the appropriate level on the subcutaneous tissue.

Referring now to Fig. 4, an apparatus 58 for creating a desired contour effect of underlying subcutaneous layers or deeper soft tissue layers which



include loculations of fat with fibrous septae made of collagen tissue is illustrated. The apparatus 58 of Fig 4, includes a porous membrane 18, electrolytic solution 20, a contacting exterior surface 22, a cooling lumen, electromagnetic electrodes 26, an electromagnetic power source 28, an electrolytic solution source 30, one or more thermal sensors 52, as well as one or more impedance monitors 54. Apparatus 58 also includes a focussing element 60 which focuses electromagnetic energy from electrolytic solution 20 to the underlying collagen tissue. Focussing element 60 and electrolytic solution 20 create a reverse thermal gradient from epidermis layer 12 to the underlying collagen tissue 14. Focussing element 62 can be, in the case of ultrasonic energy, a lens having a flat planer surface on the radiation wave incident side and a concave exit face, see *Ultrasonics Theory and Application*, by G.L. Gberman, Heart Publishing Co., New York (1959), at section 2.6. The use of such a focussing lens for ultrasonic energy with a planer wave receiving face and concave exit face is also described in the article "Deep Local Hypothermia for Cancer Therapy: Extreme Electromagnetic and Ultrasound Technics," A.Y. Cheung and A. Neyzari, *Cancer Research*, Vol. 44, pp.4736-4744, October 1984.

Radio frequencies can be the electromagnetic energy source, and various localizing technique, well known in the art, can be utilized. In one embodiment, radio frequency energy is supplied by capacitive coupling directly to epidermis layer 12 for areas close to the dermal tissue. Radio frequency induction focussing can be achieved with the use of plural focussing coils which are adaptive at the zone of interest and are elsewhere subtractive. Alternatively, radio frequency energy may be focused by having a multiple beam phased array. For concave focussing see, "Tumor reduction by radio frequency therapy response", H.H. Lavien et al., *JAMA*, Vol. 233, at 2198-2200.

Alternative radio frequency focussing methods are disclosed in "Equipment for Local Hypothermia Therapy of Cancer", C.F. Babbs et al., *Medical Instrumentation*, Vol. 16, No. 5, Sept-Oct 1982, pp.245-248.

It will be appreciated that focussing element 60 can be a convergent lens. Further, focussing element 60 can be positioned in porous membrane 18, and at the exterior 16 between epidermis layer 12 and porous membrane 18. Further, a coupling device 62 can be included which couples focussing element 60 with porous membrane 18. In one embodiment, coupling device 62 is a bracket which is positioned around a periphery of porous membrane 18, and supports focussing element 50 in relation to porous membrane 18.

In the method for tightening skin, porous membrane 18 and thermal energy source 26 are provided. A reverse thermal gradient is created which cools a surface of epidermis layer 12 while heating underlying collagen containing layers. Epidermis layer 12 as well as underlying collagen containing tissue are heated, without substantially effecting the melanocytes and other epithelial cells in epidermis layer 12, resulting in a denaturization of collagen molecules, causing a contraction of the collagen tissue and a tightening of the skin. This method can be applied numerous times. In many instances, it may be desirable to tighten the skin to a certain level and then in subsequent treatments the skin is tightened further. There may be four fine treatments to fine tune the contour effects with greater precision. In this method, collagen containing tissue is partial denatured and fat cell destruction is minimized. This is achieved by partially denaturing by cleaving heat labile cross links of the collagen molecules.

The reverse thermal gradient provides a variation in temperature throughout the various tissue layers. For example, in various embodiments, the reverse thermal gradient has a tissue surface temperature range from about 40 to 60 degrees C, and a selected underlying tissue site temperature, i.e., where scar collagen is formed or where collagen is contracted, of about 60 to 80 degrees C. In other embodiments, when the reverse thermal gradient is a diminished or equalized standard thermal gradient the temperature ranges can be much broader.

In another embodiment, a method for liposculpturing an area of the body where there is an underlying area comprised of a loculation of fat that has collagen tissue as a fibrous septae also includes creating a reverse thermal

gradient from epidermis layer 12 to the desired underlying loculation of fat layer. Sufficient electromagnetic energy is supplied through epidermis layer 12, without damaging or substantially modifying the melanocytes and other epithelial cells, through other skin layers and is focused on the collagen tissue of the fibrous  
5 septae. Electromagnetic energy partially denatures the collagen tissue with a minimal destruction of fat cells. Again, this is achieved by partially denaturizing, e.g., by cleaving, heat labial cross links of collagen molecules. The reverse thermal gradient produces a net mobilization of intra-cellular fat with diminished destruction of fat cells.

10 In yet another embodiment of the invention, thermal induction of osteoblasts in the periosteum results in callus (calcium matrix) deposition. Callus contains a higher percentage of collagen than mature bone and subsequent remodeling with thermal contraction is possible. Maturation of the remodeled callus with calcium deposition results in stable bony fusion of treated areas.

15 Without limitation, power source 28 can be an RF source. RF power source 28 feeds energy to an RF power generator 64 and then to RF electrodes 26. A multiplexer 66 measures current, voltage and temperature, at the numerous thermal sensors associated with to each RF electrode 26. RF electrodes 26 can be individually measured. Multiplexer 66 is driven by a  
20 controller 68 which can be a digital or analog controller, or a computer with software. When controller 68 is a computer it can include a CPU coupled through a system bus. On the system can be a keyboard, disk drive, or other non volatile memory systems, a display, and other peripherals, as are well known in the art. Also coupled to the bus are a program memory and a data memory.

25 An operator interface 70 includes operator controls 72 and a display 74. Controller 68 can be coupled to different types of imaging systems including ultrasonic, thermal sensors 52, and impedance monitors 54.

30 Current and voltage are used to calculate impedance. A diagnostic phase can be initially run to determine the level of treatment activity. This can be done through ultrasound as well as other means. Diagnostics can be performed both before and after treatment.

Thermal sensors 52, and thermal sensors 76 contained within RF generator 64 measure voltage and current that is delivered to the desired treatment site. The output for these sensors is used by controller 68 to control the delivery of RF power. Controller 68 can also control temperature and power. An operator set level of power and/or temperature may be determined and this will not be exceeded. Controller 68 maintains the set level under changing conditions. The amount of RF energy delivered controls the amount of power. A profile of power delivered can be incorporated in controller 68, as well as a preset amount of energy to be delivered. Feedback can be the measurement of impedance, temperature, or other indicators and occurs either at control 68 or at RF generator 64, if it incorporates a controller. For impedance measurement, this can be achieved by supplying a small amount of non therapeutic RF energy. Voltage and current are then measured to confirm electrical contact.

Circuitry, software and feedback to controller 68 result in full process control and are used to change, (i). power, (ii). the duty cycle, (iii). monopolar or bipolar energy delivery, (iv). electrolytic solution 20 delivery, flow rate and pressure and (v). can determine when the process is completed through time, temperature and/or impedance. These process variables can be controlled and varied based upon tissue temperature monitored at multiple sites on contacting exterior surface 22 as well as monitoring impedance to current flow at each RF electrode 26, indicating changes in current carrying capability of the tissue during the process. Further, controller 68 can provide multiplexing, monitor circuit continuity, and determine which RF electrode 26 is activated.

A block diagram of one embodiment of suitable processing circuitry is shown in Fig. 6. Thermal sensors 52 can be thermistors which have a resistance that varies with temperature. Analog amplifier 78 can be a conventional differential amplifier circuit for use with thermistors and transducers. The output of analog amplifier is sequentially connected by an analog multiplexer 80 to the input of an analog digital converter 82. The output of amplifier 78 is a voltage which represents the respective sensed temperatures. The digitized amplifier

output voltages are supplied by analog to digital converter 82 to a  
microprocessor 84. Microprocessor 84 calculates the temperature or impedance  
of the tissue. Microprocessor 84 can be a type 6800. However, it will be  
appreciated that any suitable microprocessor or general purpose digital or analog  
5 computer can be used to calculate impedance or temperature.

Microprocessor 84 sequentially receives and stores digital representations  
of impedance and temperature. Each digital value received by microprocessor  
84 corresponds to different temperatures and impedances.

Calculated temperature and impedance values can be indicated on display  
10 74. Alternatively, or in addition to the numerical indication of temperature or  
impedance, calculated impedance or temperature values can be compared by  
microprocessor 84 with temperature and impedance limits. When the values  
exceed predetermined temperature or impedance values a warning can be given  
on display 74 and additionally, the delivery of RF energy to its respective  
15 electrode can be decreased or multiplexed to another electrode. A control signal  
from microprocessor 84 can reduce the power level by RF generator 64, or de-  
energize the power delivered to any particular electrode. Controller 68 receives  
and stores the digital values which represent temperatures and impedances sent.  
Calculated surface temperatures and impedances can be forwarded by controller  
20 68 to display 74. If desired, the calculated surface temperature of epidermis  
layer 12 is compared with a temperature limit and a warning signal can be sent to  
display 74. Similarly, a control signal can be sent to RF power source 26 when  
temperature or impedance values exceed a predetermined level.

The foregoing description of a preferred embodiment of the invention has  
25 been presented for purposes of illustration and description. It is not intended to  
be exhaustive or to limit the invention to the precise forms disclosed. Obviously,  
many modifications and variations will be apparent to practitioners skilled in this  
art. It is intended that the scope of the invention be defined by the following  
claims and their equivalents.

**CLAIMS**

1. A method for forming and contracting scar collagen below a tissue surface in a selected tissue site, comprising:
- 5 providing an electromagnetic energy apparatus including an electromagnetic energy source and a delivery device;
- positioning the delivery device on the tissue surface;
- producing electromagnetic energy from the electromagnetic energy source;
- 10 delivering the electromagnetic energy from the delivery device through the tissue surface to the selected tissue site for a sufficient time to induce scar collagen formation in the selected tissue site; and
- contracting the scar collagen.
2. The method of claim 1, wherein the electromagnetic energy is transcutaneously delivered to the selected tissue site.
- 15 3. The method of claim 1, wherein the electromagnetic energy is percutaneously delivered to the selected tissue site.
4. The method of claim 1, wherein the electromagnetic energy is transmucosally delivered to the selected tissue site.
- 20 5. The method of claim 1, wherein the electromagnetic energy is permucosally delivered to the selected tissue site.
6. The method of claim 1, wherein the electromagnetic energy is transcutaneously delivered to the selected tissue site for a sufficient time to induce scar collagen formation in the selected tissue site with no deeper than a first degree burn formed on the tissue surface.

7. The method of claim 1, wherein the electromagnetic energy is transcutaneously delivered to the selected tissue site for a sufficient time to induce scar collagen formation in the selected tissue site with no deeper than a second degree burn formed on the tissue surface.

5 8. The method of claim 1, wherein a combination of an amount of electromagnetic energy delivered to the tissue surface and to the selected tissue site creates a reverse thermal gradient through the tissue surface to the selected tissue site.

9. The method of claim 1, wherein the selected tissue site is  
10 substantially devoid of collagen.

10. The method of claim 1, wherein the selected tissue site is deficient of collagen.

11. The method of claim 1, wherein the selected tissue site has pre-existing collagen.

15 12. The method of claim 1, wherein the electromagnetic energy source is an RF source.

13. The method of claim 1, wherein the electromagnetic energy source is a microwave source.

14. The method of claim 1, wherein the electromagnetic energy  
20 source is a short wave source.

15. The method of claim 1, wherein scar collagen is formed without ablating the surface of the soft tissue site.

16. The method of claim 1, wherein the surface of the selected tissue site is heated to a temperature range of 40 to 60 degrees C.

17. The method of claim 1, wherein the selected tissue site is heated to a temperature of 60 to 80 degrees or greater.

5 18. The method of claim 1, wherein the selected tissue site comprises soft tissue.

19. The method of claim 1, wherein the formation of the scar collagen alters a consistency of the selected tissue site.

10 20. The method of claim 1, wherein the formation of the scar collagen changes the geometry of the selected tissue site.

21. The method of claim 1, wherein the tissue site is an unstable joint with collateral ligament laxity, and a contraction of the scar collagen reduces a hypermobility of the unstable joints.

15 22. The method of claim 1, wherein the tissue site is one or more sections of an unstable spinal column, and a contraction of the scar collagen reduces a vector of spinal deviation and increases the stability of the spine.

23. A method for contracting collagen below a tissue surface in a selected tissue site, comprising:  
providing an electromagnetic energy apparatus including an  
20 electromagnetic energy source and a delivery device;  
positioning the delivery device on the tissue surface;  
producing electromagnetic energy from the electromagnetic energy  
source;



delivering the electromagnetic energy from the delivery device through  
the tissue surface to the selected tissue site for a sufficient time to contract  
10 collagen in the selected tissue site with no deeper than a first degree burn formed  
on the tissue surface.

24. The method of claim 23, wherein the collagen is contracted with  
no deeper than a second degree burn formed on the tissue surface.

25. The method of claim 23, wherein the electromagnetic energy is  
transcutaneously delivered to the selected tissue site.

5 26. The method of claim 23, wherein the electromagnetic energy is  
percutaneously delivered to the selected tissue site.

27. The method of claim 23, wherein the electromagnetic energy is  
transmucosally delivered to the selected tissue site.

10 28. The method of claim 23, wherein the electromagnetic energy is  
permucosally delivered to the selected tissue site.

29. The method of claim 23, wherein the surface of the selected  
tissue site is heated to a temperature range of 40 to 60 degrees C.

30. The method of claim 23, wherein the selected tissue site is heated  
to a temperature of 60 to 80 degrees or greater.

15 31. A method for forming callus deposition in a selected periosteum  
tissue site, comprising:

providing an electromagnetic energy apparatus including an  
electromagnetic energy source and a delivery device;

- 5                    positioning the delivery device on a surface of the selected periosteum  
tissue site;  
                      producing electromagnetic energy from the electromagnetic energy  
source;  
                      delivering the electromagnetic energy from the delivery device to the  
10                    selected periosteum tissue site for a sufficient time to induce callus formation in  
the selected periosteum tissue site; and  
                      contracting the callus.
32.     The method of claim 31, wherein the electromagnetic energy is  
transcutaneously delivered to the selected periosteum tissue site.
- 15                    33.     The method of claim 31, wherein the electromagnetic energy is  
percutaneously delivered to the selected periosteum tissue site.
34.     The method of claim 31, wherein the electromagnetic energy is  
transmucosally delivered to the selected periosteum tissue site.
35.     The method of claim 31, wherein the electromagnetic energy is  
20                    permucosally delivered to the selected periosteum tissue site.
36.     The method of claim 31, wherein the surface of the selected  
periosteum tissue site is heated to a temperature range of 40 to 60 degrees C.
37.     The method of claim 31, wherein the selected periosteum tissue  
site is heated to a temperature of 60 to 80 degrees or greater.
- 25                    38.     The method of claim 31, wherein a reverse thermal gradient is  
formed through the surface of the selected periosteum tissue site.

- 5                    39.     The method of claim 31, wherein the selected periosteum tissue site is substantially devoid of collagen.
40.     The method of claim 31, wherein the selected periosteum tissue site is deficient of collagen.
41.     The method of claim 31, wherein the selected periosteum tissue site has pre-existing collagen.
- 10                    42.     The method of claim 31, wherein the electromagnetic energy source is an RF source.
43.     The method of claim 31, wherein the electromagnetic energy source is a microwave source.
44.     The method of claim 31, wherein the electromagnetic energy source is a short wave source.
- 15                    45.     The method of claim 31, wherein the electromagnetic energy forms the callus with no more than a first degree burn formed on the surface of the selected periosteum tissue site.
46.     The method of claim 31, wherein the electromagnetic energy forms the callus with no more than a second degree burn formed on the surface of the selected periosteum tissue site.
- 20                    47.     The method of claim 31, wherein the formation of callus alters a consistency of the selected periosteum tissue site.
48.     The method of claim 31, wherein the formation of callus alters a geometry of the selected periosteum tissue site.
- 25

- 5           49. A method for contracting collagen below a tissue surface in a selected tissue site, comprising:
- providing an electromagnetic energy apparatus including an electromagnetic energy source and a delivery device;
  - positioning the delivery device on the tissue surface;
  - 10        producing electromagnetic energy from the electromagnetic energy source;
  - delivering the electromagnetic energy from the delivery device through the tissue surface to the selected tissue site for a sufficient time to contract native collagen in the selected tissue site with no deeper than a first degree burn formed
  - 15        on the tissue surface.
50. The method of claim 49, wherein the native collagen is contracted with no deeper than a second degree burn formed on the tissue surface.
51. The method of claim 49, wherein the electromagnetic energy is percutaneously delivered to the selected tissue site.
- 20        52. The method of claim 49, wherein the electromagnetic energy is permucosally delivered to the selected tissue site.
53. The method of claim 49, wherein the surface of the selected tissue site is heated to a temperature range of 40 to 60 degrees C.
54. The method of claim 49, wherein the selected tissue site is heated
- 25        to a temperature of 60 to 80 degrees or greater.

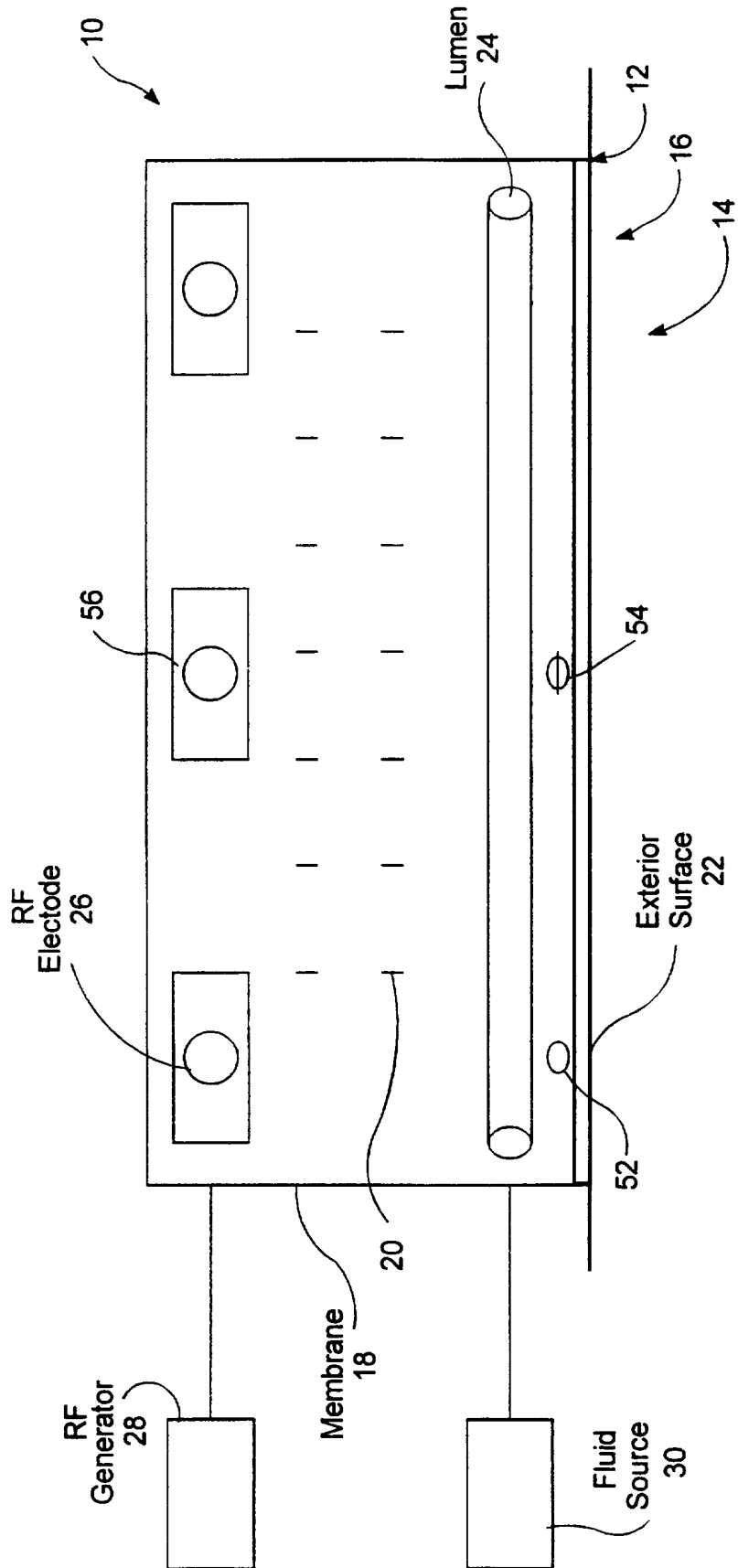

FIG.1

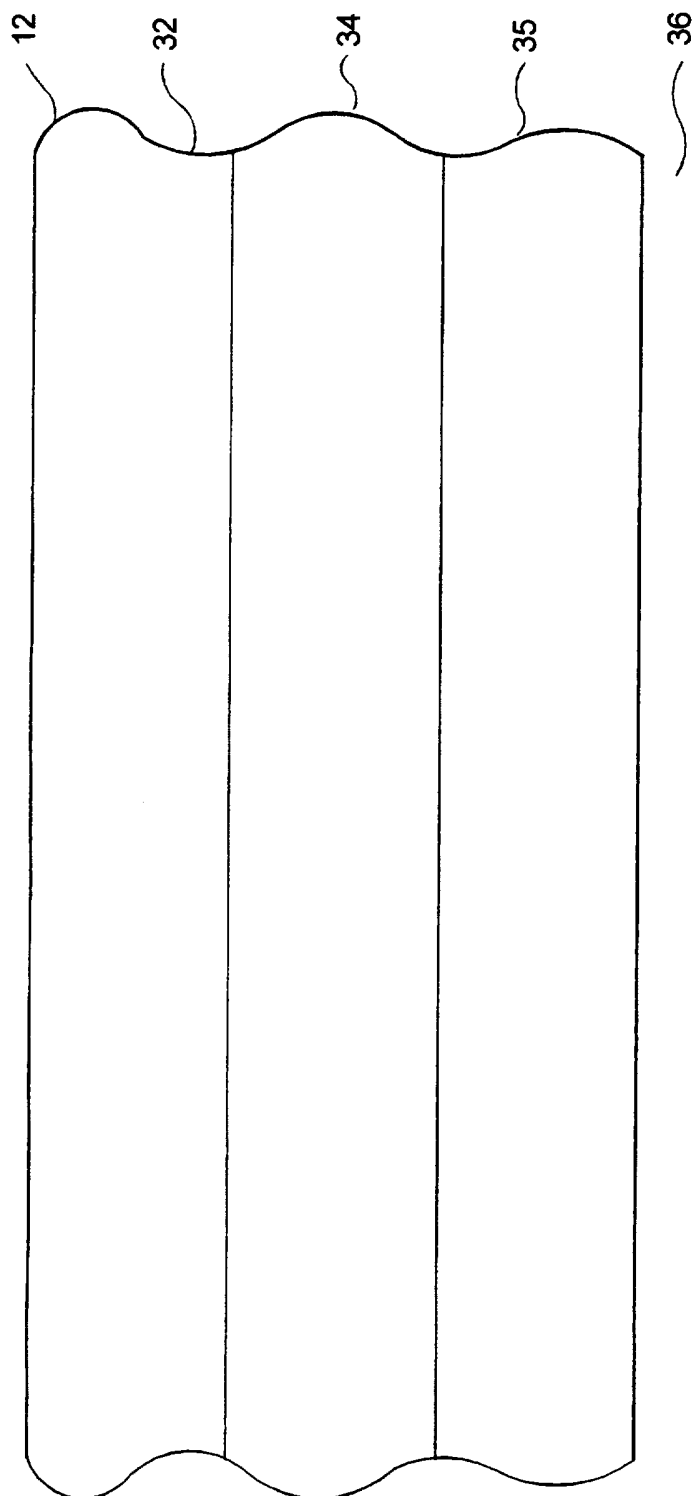

FIG. 2

3/6

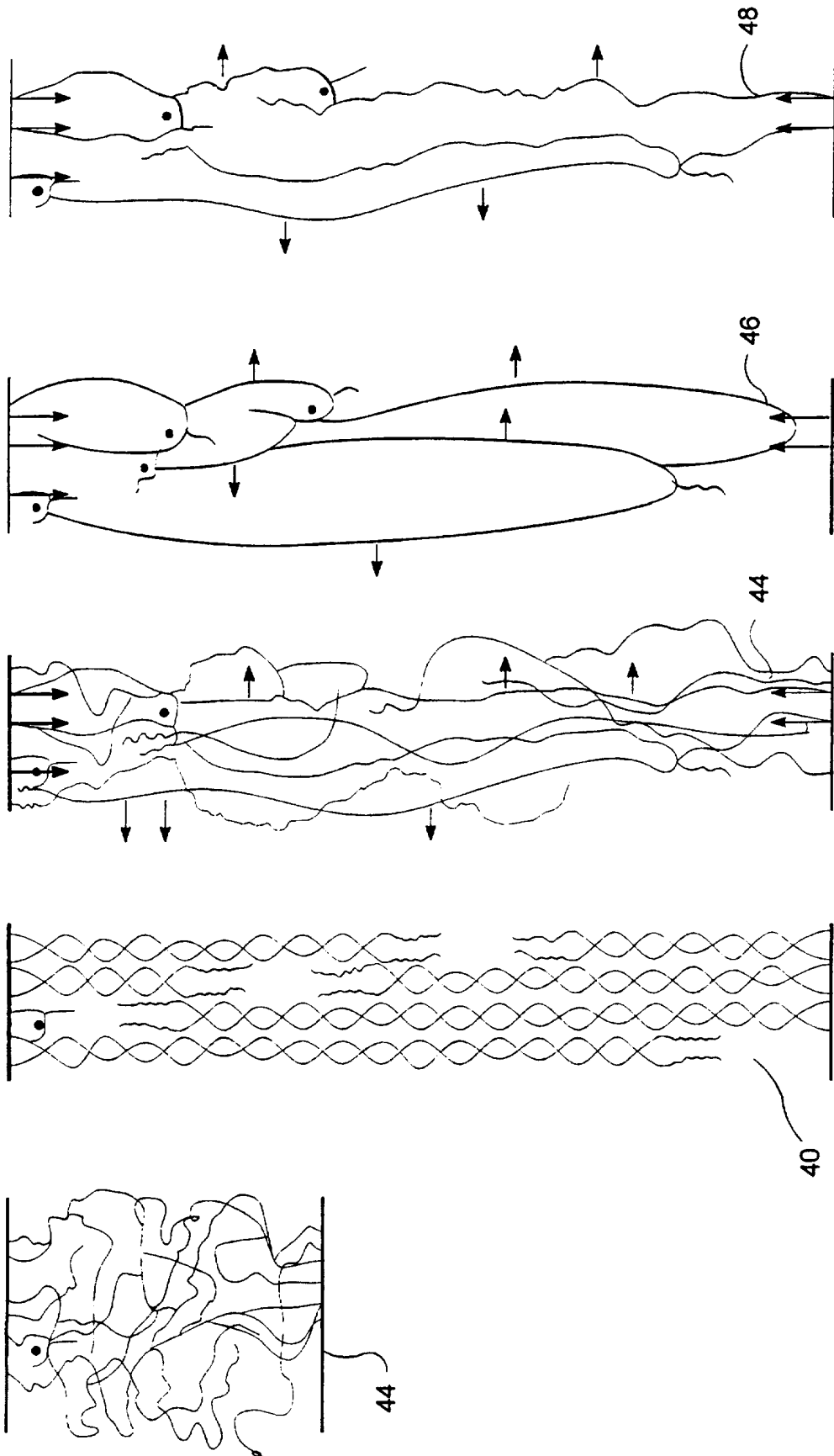

FIG.3

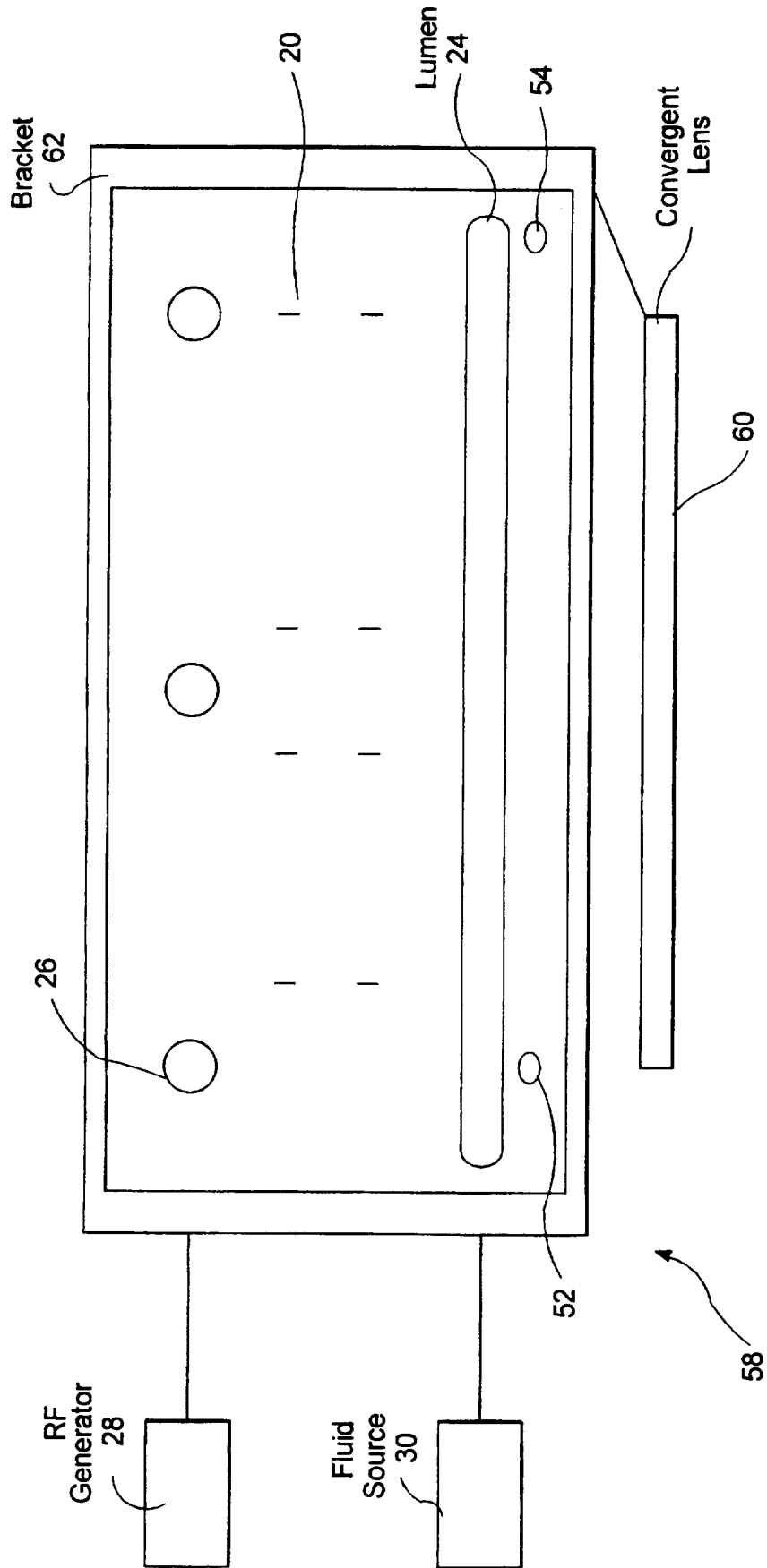

FIG.4



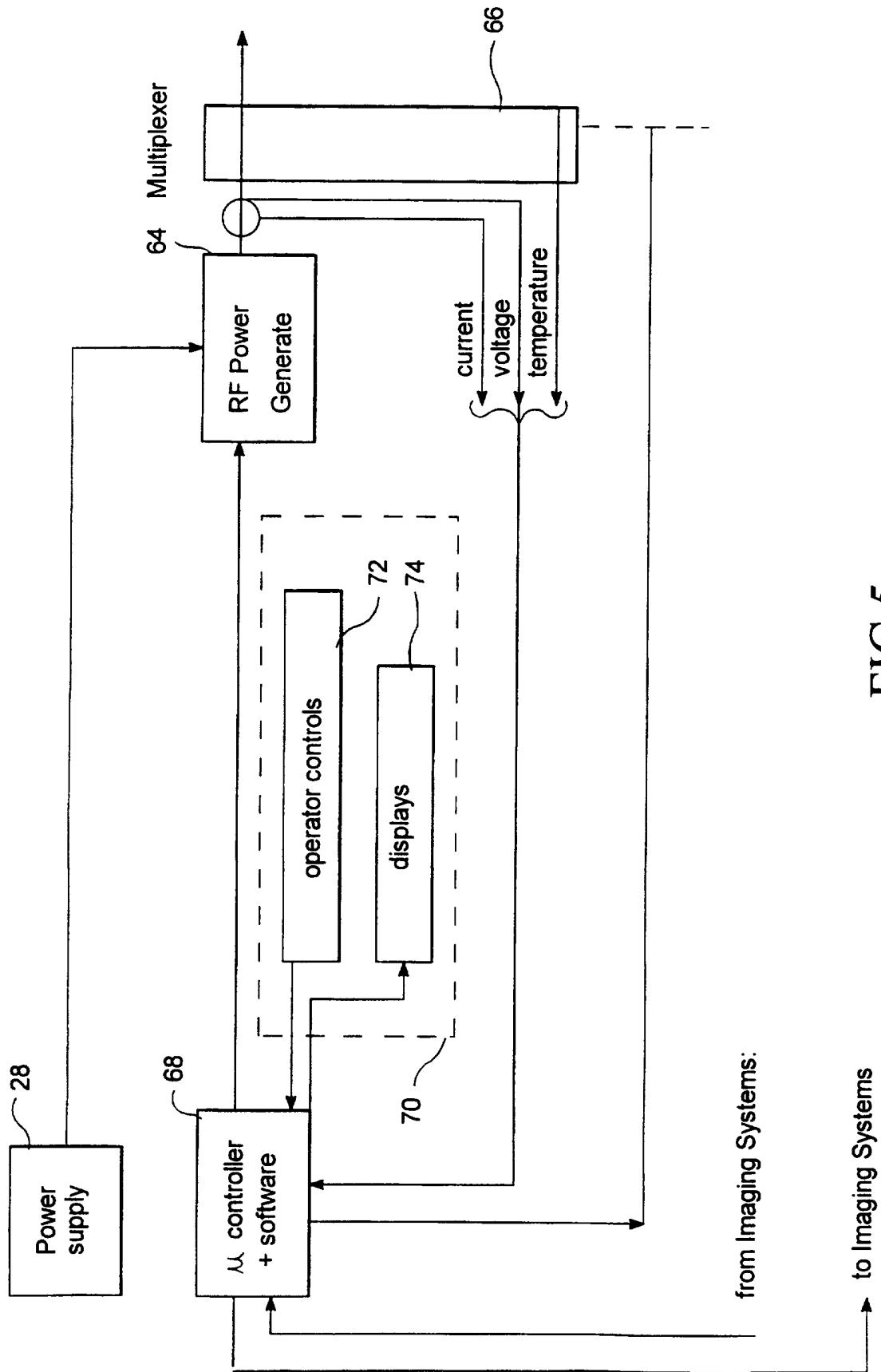

FIG. 5

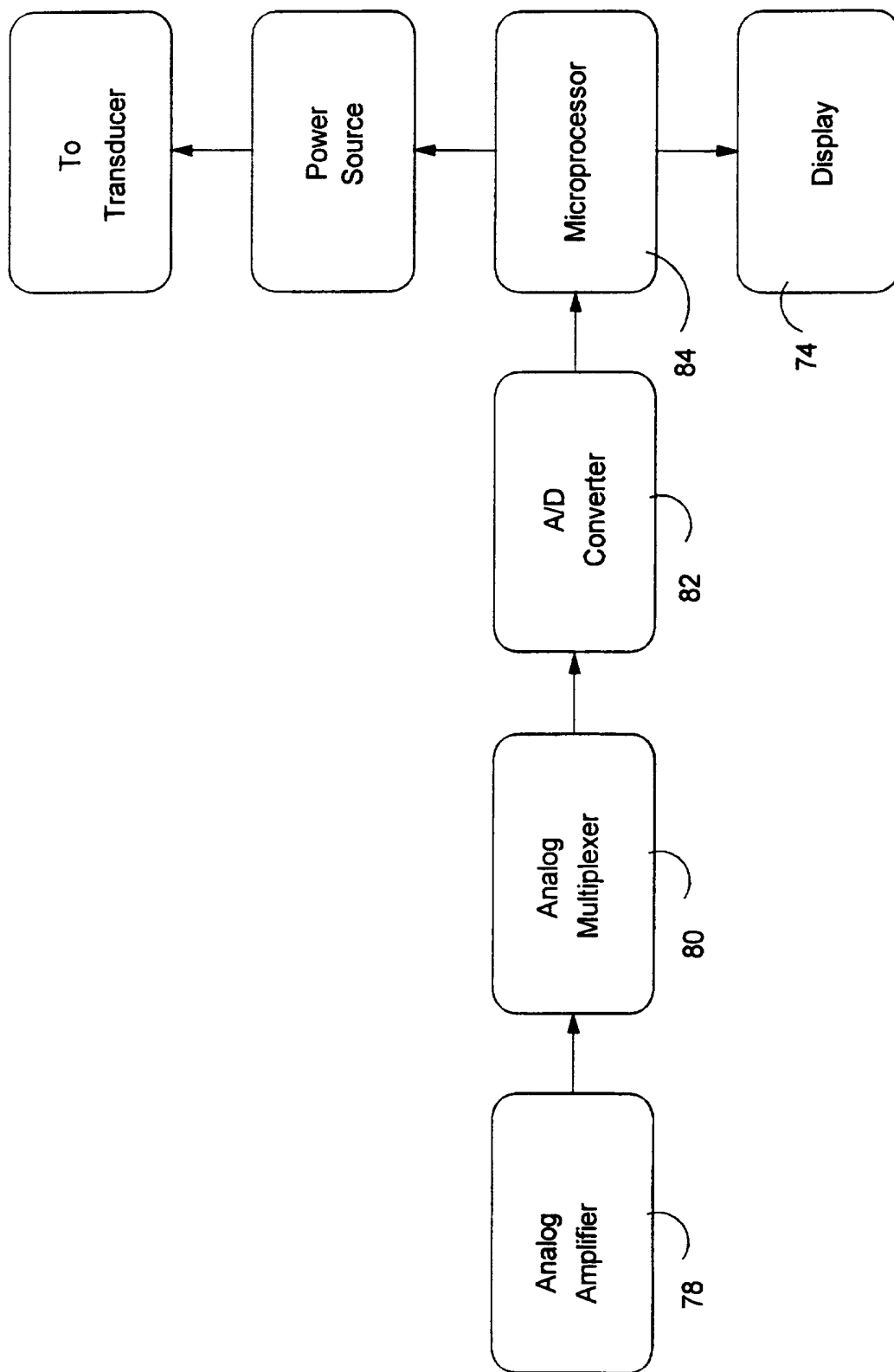

FIG.6

# INTERNATIONAL SEARCH REPORT

Intern. Application No  
PCT/US 97/00162

<b>A. CLASSIFICATION OF SUBJECT MATTER</b> IPC 6 A61B17/38 A61B17/36		
According to International Patent Classification (IPC) or to both national classification and IPC		
<b>B. FIELDS SEARCHED</b>		
Minimum documentation searched (classification system followed by classification symbols) IPC 6 A61B A61N		
Documentation searched other than minimum documentation to the extent that such documents are included in the fields searched		
Electronic data base consulted during the international search (name of data base and, where practical, search terms used)		
<b>C. DOCUMENTS CONSIDERED TO BE RELEVANT</b>		
Category *	Citation of document, with indication, where appropriate, of the relevant passages	Relevant to claim No.
A	EP 0 519 415 A (SEGNALAMENTO) 23 December 1992 ---	
A	US 5 282 797 A (CHESS) 1 February 1994 ---	
A	US 4 889 122 A (WATMOUGH) 26 December 1989 ---	
A	US 4 381 007 A (DOSS) 26 April 1983 ---	
A	US 4 140 130 A (STORM) 20 February 1979 ---	
A	WO 92 19414 A (MMTC) 12 November 1992 ---	
A	DE 31 21 683 A (MUCHA) 16 December 1982 ---	
A	FR 2 609 245 A (PHYSIOLAB) 8 July 1988 ---	
A	US 5 143 063 A (FELLNER) 1 September 1992 -----	
<input type="checkbox"/> Further documents are listed in the continuation of box C.		
<input checked="" type="checkbox"/> Patent family members are listed in annex.		
* Special categories of cited documents :		
*A* document defining the general state of the art which is not considered to be of particular relevance		
*E* earlier document but published on or after the international filing date		
*L* document which may throw doubts on priority claim(s) or which is cited to establish the publication date of another citation or other special reason (as specified)		
*O* document referring to an oral disclosure, use, exhibition or other means		
*P* document published prior to the international filing date but later than the priority date claimed		
*T* later document published after the international filing date or priority date and not in conflict with the application but cited to understand the principle or theory underlying the invention		
*X* document of particular relevance; the claimed invention cannot be considered novel or cannot be considered to involve an inventive step when the document is taken alone		
*Y* document of particular relevance; the claimed invention cannot be considered to involve an inventive step when the document is combined with one or more other such documents, such combination being obvious to a person skilled in the art.		
*&* document member of the same patent family		
Date of the actual completion of the international search	Date of mailing of the international search report	
26 March 1997	03.04.97	
Name and mailing address of the ISA European Patent Office, P.B. 5818 Patentlaan 2 NL - 2280 HV Rijswijk Tel. (+ 31-70) 340-2040, Tx. 31 651 epo nl, Fax (+ 31-70) 340-3016		Authorized officer  Barton, S

# INTERNATIONAL SEARCH REPORT

International application No.

PCT/US 97/00162

## Box I Observations where certain claims were found unsearchable (Continuation of item 1 of first sheet)

This International Search Report has not been established in respect of certain claims under Article 17(2)(a) for the following reasons:

1.  Claims Nos.:  
because they relate to subject matter not required to be searched by this Authority, namely:  
**Meaningful search not possible on the basis of all claims**  
**PCT Rule 39.1 (iv)**
2.  Claims Nos.:  
because they relate to parts of the International Application that do not comply with the prescribed requirements to such an extent that no meaningful International Search can be carried out, specifically:
3.  Claims Nos.:  
because they are dependent claims and are not drafted in accordance with the second and third sentences of Rule 6.4(a).

## Box II Observations where unity of invention is lacking (Continuation of item 2 of first sheet)

This International Searching Authority found multiple inventions in this international application, as follows:

1.  As all required additional search fees were timely paid by the applicant, this International Search Report covers all searchable claims.
2.  As all searchable claims could be searched without effort justifying an additional fee, this Authority did not invite payment of any additional fee.
3.  As only some of the required additional search fees were timely paid by the applicant, this International Search Report covers only those claims for which fees were paid, specifically claims Nos.:
4.  No required additional search fees were timely paid by the applicant. Consequently, this International Search Report is restricted to the invention first mentioned in the claims; it is covered by claims Nos.:

Remark on Protest

- The additional search fees were accompanied by the applicant's protest.
- No protest accompanied the payment of additional search fees.

# INTERNATIONAL SEARCH REPORT

Information on patent family members

International Application No

PCT/US 97/00162

Patent document cited in search report	Publication date	Patent family member(s)	Publication date
EP 519415 A	23-12-92	IT 1247029 B JP 5220230 A	12-12-94 31-08-93
US 5282797 A	01-02-94	US 5057104 A US 5486172 A	15-10-91 23-01-96
US 4889122 A	26-12-89	DE 3683468 A EP 0225120 A	27-02-92 10-06-87
US 4381007 A	26-04-83	CH 656303 A DE 3215832 A JP 57183850 A	30-06-86 18-11-82 12-11-82
US 4140130 A	20-02-79	NONE	
WO 9219414 A	12-11-92	AU 1893692 A CA 2092406 A US 5272301 A	21-12-92 27-10-92 21-12-93
DE 3121683 A	16-12-82	NONE	
FR 2609245 A	08-07-88	NONE	
US 5143063 A	01-09-92	WO 8907468 A	24-08-89