

W. C. HOOPER.
Pinking-Machines.

No. 132,532.

Patented Oct. 29, 1872.

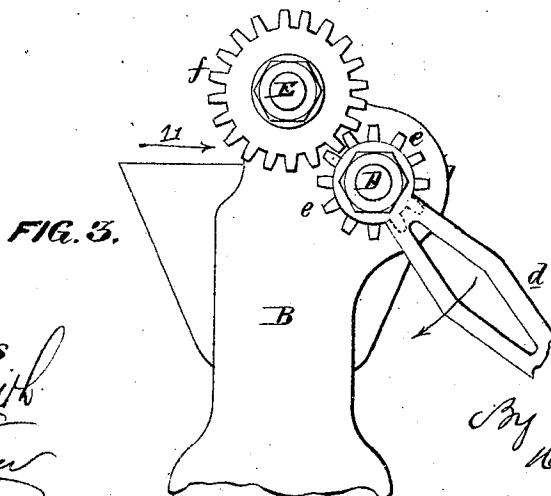
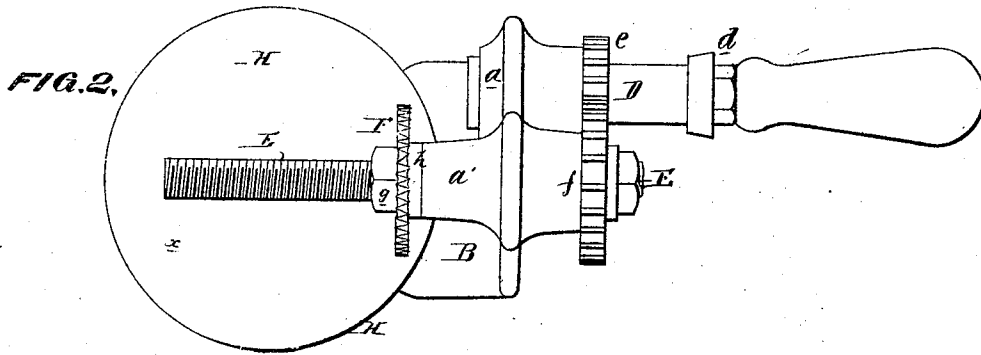
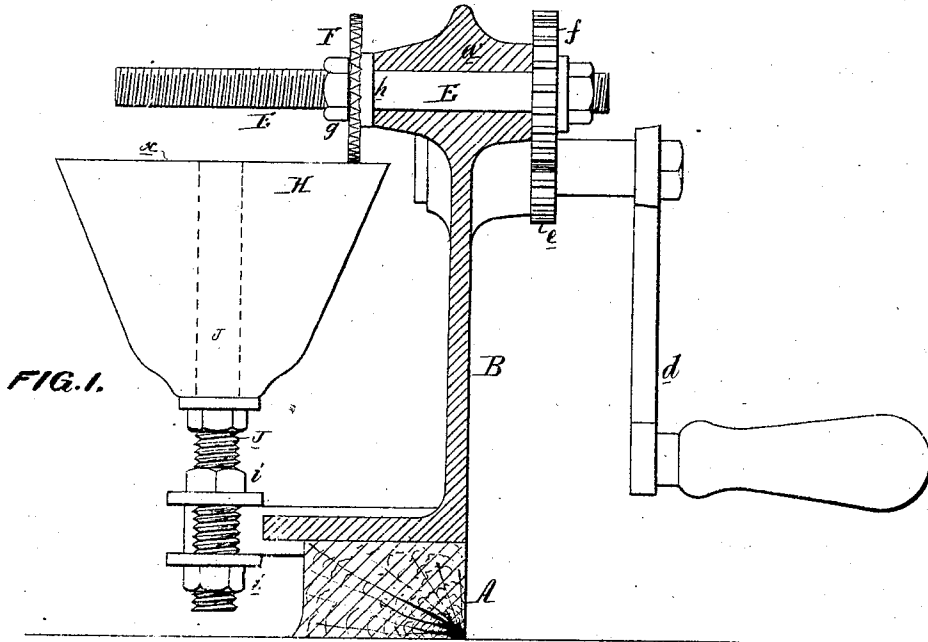

WITNESSES
Harry Smith
John Parker

W. C. Hooper
By his attys.
Howson and Son

UNITED STATES PATENT OFFICE.

WILLIAM C. HOOPER, OF PHILADELPHIA, PENNSYLVANIA.

IMPROVEMENT IN PINKING-MACHINES.

Specification forming part of Letters Patent No. 132,532, dated October 29, 1872; antedated October 25, 1872.

To all whom it may concern:

Be it known that I, WILLIAM C. HOOPER, of Philadelphia, Pennsylvania, have invented an Improved Pinking-Machine, of which the following is a specification:

My invention consists of the combination, in a pinking-machine, of a rotating cutter with a rotating bed, the axis of which is at right angles or nearly so to that of the said cutter; and my invention also consists of certain other improvements, fully described hereafter, in the construction of the machine.

In the accompanying drawing, Figure 1 is a vertical section of my improved pinking-machine; Fig. 2, a plan view; and Fig. 3, an end view of the upper portion of the same.

A represents the base of the machine, arranged to be attached in any suitable manner to a bench or table; and B is the frame secured to the said base, and cast in the present instance in one piece, with bearings *a* and *a'* at the top for the driving-shaft D and cutter-spindle E. The driving-shaft is provided with an operating-crank, *d*, and has also a toothed pinion, *e*, which gears into a pinion, *f*, on the cutter-spindle having a greater number of teeth. These pinions are made interchangeable in order to enable the cutter-spindle to be rotated either slower or faster than the driving-shaft; but it is generally preferable to attach the larger pinion to the cutter-spindle in order to increase the power of the latter. The gearing also enables the cutter-spindle to be rotated in a direction opposite that of the driving-shaft, the object of which will be hereafter described. The cutting-wheel F is of the usual construction, its periphery or cutting edge being waved, scalloped, or zigzagged, according to the nature of the cut which it is desired to make, and the said wheel is secured to the threaded portion of the spindle E, between a nut, *g*, and shoulder *h*, or between two nuts, the said threaded portion of the spindle extending over the cutting-bed H so as to enable the wheel to be adjusted to any desired position in respect to the latter. The bed H is, in the present instance, of a conical form, although this is not material, and it has a flat upper surface, *x*, and is secured to and arranged to turn freely upon a spindle, J, at right angle or thereabout to the cutter-spin-

dle E. The lower threaded end of the spindle J extends through a slot formed for its reception in the frame B, and is secured to the latter by two nuts, *i i*, in the manner plainly shown in Fig. 1; this method of attachment enabling the said spindle and, consequently, the rotating bed H to be raised and lowered, and thus properly adjusted in respect to the cutter F.

In using the machine, the operator turns the crank *d* with his right hand in the direction of the arrow, Fig. 3, and, consequently, rotates the cutter-spindle and its wheel in the opposite direction, the bed H being also rotated by the cutter-wheel, which bears upon it, as shown in Fig. 1. With his left hand the operator passes the fabric or other material to be cut between the wheel F and its bed in the direction indicated by the arrow 1 in Fig. 3, the work as it is cut being carried away from the operator, owing to the direction of the motion of the cutter, so that it therefore can be guided to the latter much more readily than if it moved in the opposite direction, which would be the case if the crank were attached directly to the cutter-spindle, as in other machines of this class, unless the said crank was turned toward instead of from the operator, which would be very inconvenient. The flat upper surface of the bed H affords a convenient rest for the work, and enables the usual fixed rests, used in connection with the cylinders, which are ordinarily combined with the cutters of pinking-machines, to be dispensed with.

Owing to the method of connecting the cutter to its spindle it can be adjusted upon the latter so as to bear upon any portion of the surface of the rotating bed, and when the latter has become irregular from continued use it can be detached from the machine and its upper surface smoothed off, after which it can be reattached and raised, by means of its adjusting-nuts *i i*, until again brought in contact with the cutting-wheel.

I claim as my invention—

1. A pinking-machine in which a cutter, F, is combined with a rotating bed, H, the axis of which is at right angles or nearly so to that of the said cutter.

2. The spindle J of the rotating bed secured

to the frame of the machine, and rendered vertically adjustable thereon by nuts *i i*, as described.

3. The combination, in a pinking-machine, of the driving-shaft *D*, cutter-spindle *E*, its adjustable cutter, and wheels *e* and *f* of different diameters, and interchangeable, as and for the purpose specified.

In testimony whereof I have signed my name to this specification in the presence of two subscribing witnesses.

WM. C. HOOPER.

Witnesses:

WM. A. STEEL,
HARRY W. DOUTY.