

J. GRIFFEN.  
Muzzle-Loading Fire-Arm.

No. 13,984.

Patented Dec. 25, 1855.

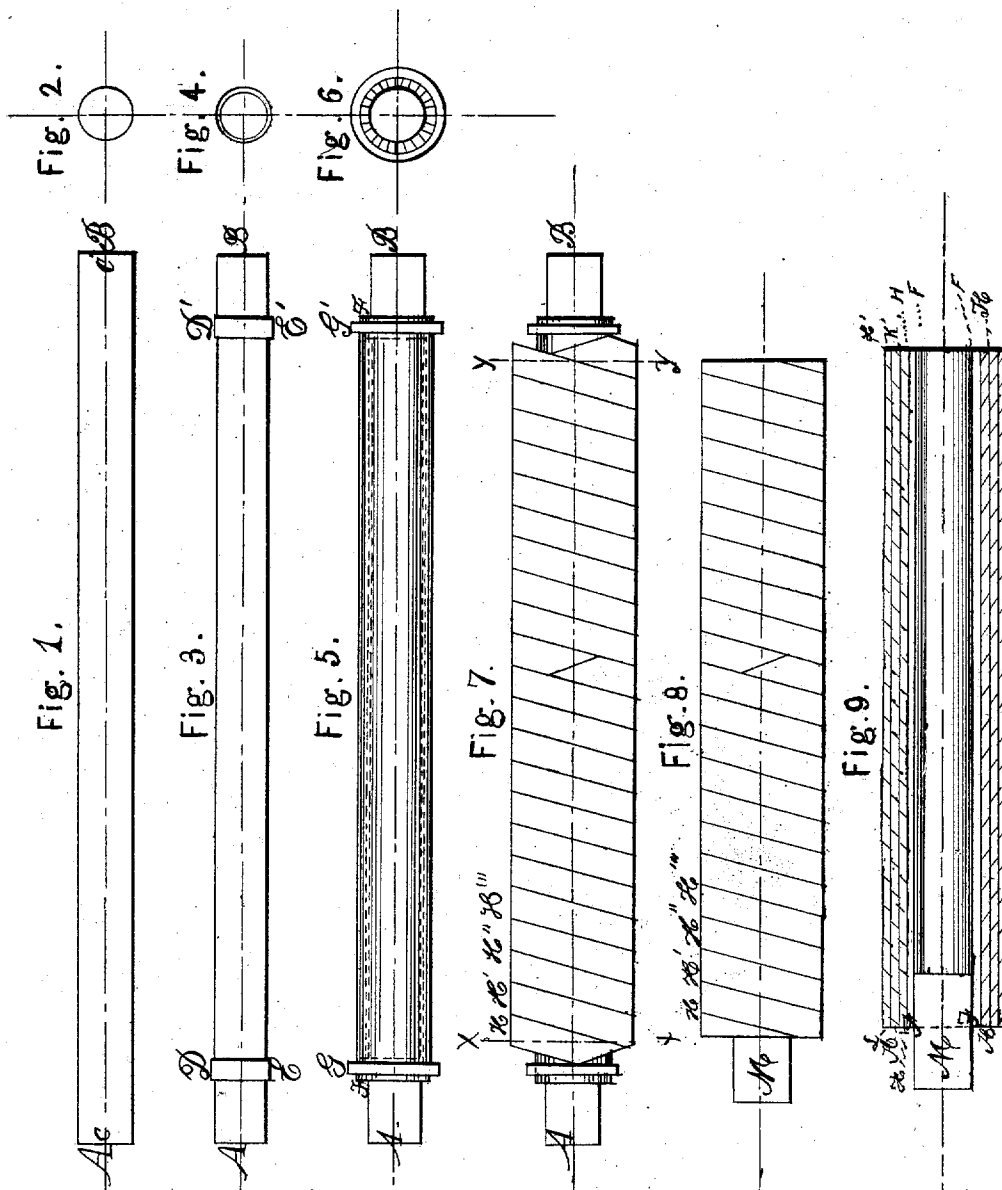

Witnesses:  
*Samuel M. Hughes*  
*Henry B. Ramsey*

Inventor:  
*John Griffen*

# UNITED STATES PATENT OFFICE.

JOHN GRIFFEN, OF SAFE HARBOR, PENNSYLVANIA.

## IMPROVED MANUFACTURE OF WROUGHT-IRON CANNON.

Specification forming part of Letters Patent No. 13,984, dated December 25, 1855.

*To all whom it may concern:*

Be it known that I, JOHN GRIFFEN, of Safe Harbor, Lancaster county, Pennsylvania, have invented a new and useful Improvement in the Manufacture of Wrought-Iron Cannon, of which the following is a full and exact description, reference being had to the annexed description, and to the accompanying drawings, in which—

Figure 1 represents a side view of the mandrel on which is formed the pile or faggot out of which my cannon is made. Fig. 2 is a vertical transverse section of the same. Fig. 3 represents the mandrel with the two end wings fitted to it. Fig. 4 is a vertical transverse section of the same. Fig. 5 is a side view of a series of central longitudinal bars arranged in a cylindrical form around the mandrel to form the bore or interior of the cannon. Fig. 6 represents a vertical transverse section of the same. Fig. 7 represents a side view of the faggot or pile out of which the cannon is to be made in the second stage of preparation, showing a series of iron bands wrapped spirally around the central bars of Figs. 5 and 6. Fig. 8 represents a side view of the faggot or pile turned off at its ends, and having a plug or piece inserted to form the breech. Fig. 9 is a vertical longitudinal section of the same.

Wrought-iron cannons have been heretofore manufactured by bars of iron surrounded by bands of iron, and then the whole mass welded together with the hammer.

The nature of my improvement consists in an improved mode of preparing the faggot or pile from which the cannon is to be made, and an improved process of treating the mass in order effectually to weld and unite the parts together.

In order to enable others skilled in the art to make and use my improvement, I proceed to describe my method or process of manufacture of wrought-iron guns.

I first take a mandrel of round iron about one-half larger than the bore of the cannon is intended to be. This is shown at A B in Figs. 1 and 2. Centers are bored in each extremity of this mandrel at *c* and *c'*. Upon the mandrel, and near each of its extremities, bands D E and D' E' are placed. The distance D D' between these bands must be a little greater than the entire length intended to be given to the pile for the cannon, and the

thickness of these bands must be such that the outer diameter of the band shall be less than the intended bore of the pile for the cannon. The mandrel B thus prepared is placed in a lathe, the mandrel being supported at its centers *c* and *c'* by the points of the lathe in the usual manner. A series of longitudinal bars, F F', are fitted upon the rings D E and D' E', as shown in Figs. 5 and 6. These bars F F' are curved transversely into the form of segments of a circle, as shown by the end view Fig. 6, and are carefully fitted together around the mandrel. These bars F F' extend in length just beyond the rings D E and D' E', and are about three-fourths of an inch thick and three-fourths of an inch wide. Around the outside of these bars I place two temporary rings or clamps, G and G', Fig. 5, for the purpose of holding the longitudinal bars F F' F' F' firmly in their place. I then take flat iron of any convenient width, either square on the edge or beveled, and, having heated this banding soft enough to prevent springing, I commence at one end of the prepared pile of bars, (shown in Fig. 5,) and wind the band of iron spirally around the pile of longitudinal bars, as shown at H H' H'' H''', &c., in Fig. 7. This spiral winding is effected most conveniently by revolving the mandrel A B upon the centers *c* and *c'*. The edges of the bar H H' H'' H''', which compose the spiral, are to be fitted in close contact. The longitudinal bars having been wound from end to end with the spiral coil, as shown in Fig. 7, a second coil, precisely like the first, is in like manner wound upon the first one from end to end of the pile, and upon the second coil a third coil is in like manner wound until the required thickness of the cannon is obtained. Each succeeding coil is so wound as to cover the series of joints in the preceding coil. The ends of the coil are then cut off square in the lathe at the lines X X, Y Y, Fig. 7, which is just inside of the rings D E, D' E', and G and G', and the mandrel A B, being thus released, is withdrawn. The pile then presents the appearance shown externally in Fig. 8 and internally in Fig. 9, being composed of a series of longitudinal bars, F F' F' F', and a series of overlapping spiral coils, H H', K K', L L'. A plug of iron, M, is then inserted into one end of the bore or central hole to form the breech. If the cannon be of small size, this

end piece can be inserted without being first heated; but if the cannon be of large size then the piece M should not be inserted until both it and the rest of the cannon have been brought to a welding-heat. The piece M should always project outward sufficiently to form the knob of the gun.

The pile for the gun, arranged and made as above described, is charged or placed in a heating-furnace, and the entire mass brought to a high welding-heat. The mass is then "upset," as it is technically termed, by placing a heavy mass of iron against one end and striking a series of heavy blows against the other end. By this means all the edges of the spiral coils are brought firmly into contact and practically welded. The pile or faggot is then withdrawn from the furnace, and is passed rapidly through a series of grooves formed between pairs of large rolls similar to those ordinarily used for rolling iron, thus welding the mass and reducing it to its proper size. The taper may then be given to the cannon either by rollers especially prepared for the purpose or by the tilt-hammer. The cannon is then ready to receive the trunnions, which may be welded on at a forge-fire or by a heating-furnace prepared for that purpose. The gun is then to be finished in the ordinary way by turning and boring.

By the above-described process of preparation and manufacture the interior of the cannon is somewhat smaller in diameter than the bore is intended to be, so as to allow for its being bored out to size. The longitudinal bars form the interior surface of the bore, and the fibers of these bars remain in a direction parallel with the bore, and thus give smoothness to the bore, while the fibers composing the enveloping-coils run nearly at right angles to the direction of the bore, and thus give transverse resisting strength to the cannon, and the coils are wound one above another, so as to cover the joints, and thus additional strength is given.

Numerous attempts have been formerly made to manufacture wrought-iron cannon; but these have been defective, either in the mode of preparing the pile or the mode of treating the prepared mass in welding its parts together, or they have been defective from both these causes.

The features of my improvement are the employment of a series of longitudinal central bars to form the bore, (these may be made of cast or other steel, if desired, and thus the wear or injury to the bore by the ball be greatly diminished,) in combination with a series of comparatively-thin overlapping bands wound around the central bars; and the welding of the entire mass at one operation between roll-

ers, instead of by a series of blows under the tilt-hammer.

The advantages of my mode of preparing the pile by combining central bars and surrounding bands is that it is specially adapted to the novel mode of welding cannon adopted by me—namely, between rolls. The pieces of iron composing the bars and coils, being of comparatively small dimensions, can be carefully examined and their quality and condition ascertained, and the effect of the rolls is to cause the welding-force to be so applied as to unite perfectly the contiguous edges and surfaces composing the mass, and thus produce a homogeneous and entire mass, and at the same time there is avoided the necessity for successive heating or reheating of the whole mass, which is required when the welding is effected by means of the tilt-hammer or forge, as has been previously described.

I have discovered by careful observation and experiment that cannon of considerable size, and probably the largest sizes, prepared in the manner above described can be perfectly welded together at one or two passes through each groove of the series of rolls, so as to present a homogeneous mass throughout without injuring the molecular arrangement of the iron by continued reheating, and without crushing or heating the fibers of particular parts, while, on the other hand, I have observed that in guns welded under the tilt-hammer the welding is not uniform throughout. The fiber of the iron in certain parts is crushed by the local action of the tilt-hammer, and the molecular condition of the mass is changed and weakened by the repeated and long-continued heating and reheating thereof.

Having thus discovered that the mode of preparing the pile or faggot above described is specially adapted to being welded under the roller, and that welding such a prepared mass by means of rolling is entirely practicable and will secure a more homogeneous and perfect union of the parts without weakening or rupturing the fiber, I do not desire to claim the above-described mode of preparing the pile or faggot when the faggot so prepared is welded by blows or under the hammer; but

What I do claim, and desire to secure by Letters Patent, is—

The manufacture of wrought-iron cannon by forming the faggot or pile of longitudinal bars surrounded by a series of bands of iron and the welding together the whole mass by passing it between rollers.

JOHN GRIFFEN.

Witnesses:

SAMUEL M. WRIGHT,  
HENRY B. RAMSAY.