

(19)



(11)

EP 4 252 568 B1

(12)

EUROPEAN PATENT SPECIFICATION

(45) Date of publication and mention of the grant of the patent:
12.03.2025 Bulletin 2025/11

(51) International Patent Classification (IPC):
A24F 40/46 ^(2020.01) **A24F 40/20** ^(2020.01)
A24F 40/40 ^(2020.01)

(21) Application number: **23187462.9**

(52) Cooperative Patent Classification (CPC):
A24F 40/46; A24F 40/20; A24F 40/40

(22) Date of filing: **11.12.2020**

(54) **FLAVOR INHALER**

AROMA INHALATOR

INHALATEUR D'ARÔME

(84) Designated Contracting States:
AL AT BE BG CH CY CZ DE DK EE ES FI FR GB GR HR HU IE IS IT LI LT LU LV MC MK MT NL NO PL PT RO RS SE SI SK SM TR

(72) Inventors:
• **SUMII, Tateki**
Sumida-ku, Tokyo, 130-8603 (JP)
• **INOUE, Yasunobu**
Sumida-ku, Tokyo, 130-8603 (JP)
• **YAMADA, Manabu**
Sumida-ku, Tokyo, 130-8603 (JP)

(43) Date of publication of application:
04.10.2023 Bulletin 2023/40

(74) Representative: **Hoffmann Eitle**
Patent- und Rechtsanwälte PartmbB
Arabellastraße 30
81925 München (DE)

(62) Document number(s) of the earlier application(s) in accordance with Art. 76 EPC:
20965137.1 / 4 260 720

(73) Proprietor: **Japan Tobacco Inc.**
Tokyo 105-6927 (JP)

(56) References cited:
WO-A1-2020/074604 US-A1- 2020 008 476

EP 4 252 568 B1

Note: Within nine months of the publication of the mention of the grant of the European patent in the European Patent Bulletin, any person may give notice to the European Patent Office of opposition to that patent, in accordance with the Implementing Regulations. Notice of opposition shall not be deemed to have been filed until the opposition fee has been paid. (Art. 99(1) European Patent Convention).

Description

TECHNICAL FIELD

[0001] The present invention relates to a flavor inhaler and a smoking system comprising the flavor inhaler.

BACKGROUND ART

[0002] Conventionally, there have been known flavor inhalers for inhaling a flavor or the like without burning a material. The flavor inhalers include, for example, a chamber that contains a flavor generation article, a heater that heats the flavor generation article contained in the chamber, and a heat insulation member that suppresses transfer of the heat of the heater to a housing (for example, refer to WO 2020-035454 A1). In WO 2020-035454 A1, a top and a base hold the heat insulation member and a sleeve so as to sandwich them axially.

[0003] WO 2020/074604 A1 is related to the preamble of claim 1.

SUMMARY OF INVENTION

TECHNICAL PROBLEM

[0004] A member disposed near the heater may expand due to the heat of the heater. Therefore, if such a member is completely fixed, the member may be, for example, buckled when the fixed member expands thermally. Further, if a member made from a fragile material such as an aerogel sheet is completely fixed to the housing, this member may also be broken when an impact is applied to the flavor inhaler from outside, due to a failure to buffer this impact and transmission of the impact to the member itself.

[0005] One of objects of the present invention is to prevent a member constituting a flavor inhaler from being broken.

SOLUTION TO PROBLEM

[0006] According to the invention, a flavor inhaler in accordance with claim 1 and a smoking system in accordance with claim 16 are provided.

[0007] According to a first aspect of the present disclosure, the tubular unit is held by the holding unit movably in the axial direction or the first direction. In other words, the tubular unit is not completely fixed and the flavor inhaler includes a space for allowing the tubular unit to move, and therefore the tubular unit can thermally expand in this space and can be prevented from being buckled. Further, even if an impact is applied to the flavor inhaler from outside, the tubular unit can buffer the impact by moving and can be prevented from being broken. In the present specification, the tubular unit can be a tubular member having any shape such as a cylindrical shape or a square tubular shape. Further, "holding" in the present

specification means restricting a movement of a target in such a manner that the target is placed within a predetermined region, and is not limited to physically gripping or holding the target.

[0008] According to a second aspect, in the first aspect, the holding unit includes a first restriction unit configured to restrict a movement of the tubular unit in the first direction.

[0009] According to the second aspect, while the tubular unit is movable in the first direction, the first restriction unit can restrict the movement of the tubular unit in the first direction. Therefore, the tubular unit can be prevented from unlimitedly moving in the first direction, thereby being prevented from colliding with another member (for example, the housing or the containing unit).

[0010] According to a third aspect, in the second aspect, the first restriction unit is configured to restrict a movement in a second direction perpendicular to the axial direction and the first direction.

[0011] According to the third aspect, the first restriction unit restricts the movements of the tubular unit in the first direction and the second direction. Therefore, the tubular unit can be prevented from unlimitedly moving in the first direction and the second direction, thereby being prevented from colliding with another member (for example, the housing or the containing unit).

[0012] According to a fourth aspect, in the second or third aspect, the first restriction unit includes an inner first restriction unit located inside the tubular unit.

[0013] According to the fourth aspect, while the tubular unit is movable in the first direction, the inner first restriction unit can restrict the movement of the tubular unit in the first direction. This eliminates the necessity of providing a member for restricting the movement of the tubular unit in the first direction outside the tubular unit and can omit a space therefor, and therefore can curb an increase in the size of the flavor inhaler.

[0014] According to a fifth aspect, in the fourth aspect, the flavor inhaler satisfies $D1 > D2$, assuming that $D1$ represents an inner diameter of the tubular unit and $D2$ represents a diameter of an imaginary circle circumscribed around the inner first restriction unit as viewed from the axial direction of the tubular unit.

[0015] According to the fifth aspect, a space is created between the inner first restriction unit and the tubular unit when the inner first restriction unit is disposed inside the tubular unit. As a result, while the tubular unit is movable in the first direction, the movement of the tubular unit in the first direction can be restricted by the inner first restriction unit. In the present specification, the inner diameter of the tubular unit in a case where the tubular unit has a shape different from a cylindrical shape such as a square tubular shape refers to a diameter of an imaginary circle inscribed in the inner surface of the tubular unit.

[0016] According to a sixth aspect, in the fifth aspect, a difference between $D1$ and $D2$ is 1 mm or smaller.

[0017] According to the sixth aspect, the inner first

restriction unit can be substantially loosely fitted inside the tubular unit. Due to that, a space required for the movement of the tubular unit can be reduced while the tubular unit is movable in the first direction. As a result, the flavor inhaler can curb an increase in the size thereof. Further, because being able to reduce the range where the tubular unit is movable, the flavor inhaler prevents the position of the tubular unit from being largely misaligned from the designed layout position thereof in the flavor inhaler, thereby preventing the performance of the flavor inhaler from deviating from the designed performance. Further, the tubular unit is prevented from being damaged due to a large swing of the tubular unit.

[0018] According to a seventh aspect, in the fifth or sixth aspect, the inner first restriction unit includes at least two protrusion portions protruding in the first direction. The imaginary circle is circumscribed around the at least two protrusion portions.

[0019] According to the seventh aspect, the protrusion portions of the inner first restriction unit are circumscribed by the imaginary circle, and therefore these protrusion portions can contact the inner surface of the tubular unit. In other words, the inner first restriction unit does not contact the inner surface of the tubular unit throughout the entire circumference thereof. Therefore, compared to a configuration in which the inner first restriction unit contacts the inner surface of the tubular unit throughout the entire circumference thereof, the flavor inhaler can suppress transfer of the heat of the inner first restriction unit to the tubular unit. Accordingly, especially in the case where the containing unit is heated, the flavor inhaler suppresses transfer of the heat to the tubular unit from the inner first restriction unit located closer to the containing unit than the tubular unit is, thereby suppressing dissipation of the heat of the containing unit to outside as a result thereof.

[0020] According to an eighth aspect, in the seventh aspect, the protrusion portions include top portions shaped so as to conform with an inner surface of the tubular unit as viewed from the axial direction, respectively. The imaginary circle is circumscribed around the top portions. The flavor inhaler satisfies $L1 > L2$, assuming that $L1$ represents a circumferential length of the inner surface of the tubular unit and $L2$ represents a sum of lengths of portions of the top portions that are circumscribed by the imaginary circle.

[0021] According to the eighth aspect, the inner first restriction unit does not contact the inner surface of the tubular unit throughout the entire circumference thereof. Therefore, compared to the configuration in which the inner first restriction unit contacts the inner surface of the tubular unit throughout the entire circumference thereof, the flavor inhaler can suppress transfer of the heat of the inner first restriction unit to the tubular unit. Accordingly, especially in the case where the containing unit is heated, the flavor inhaler suppresses transfer of the heat to the tubular unit from the inner first restriction unit located closer to the containing unit than the tubular unit is,

thereby suppressing dissipation of the heat of the containing unit to outside as a result thereof.

[0022] According to a ninth aspect, in the eighth aspect, $L1$ and $L2$ satisfy $L2 < 0.5 \times L1$.

[0023] According to the ninth aspect, the inner first restriction unit can contact the inner surface of the tubular unit over a further smaller area. As a result, the flavor inhaler can suppress transfer of the heat of the inner first restriction unit to the tubular unit. Accordingly, especially in the case where the containing unit is heated, the flavor inhaler further suppresses transfer of the heat to the tubular unit from the inner first restriction unit located closer to the containing unit than the tubular unit is, thereby further suppressing dissipation of the heat of the containing unit to outside as a result thereof.

[0024] According to a tenth aspect, in any of the fourth to sixth aspects, the inner first restriction unit includes an annular portion located between the containing unit and the tubular unit.

[0025] According to the tenth aspect, in a case where the cross-sectional shape of the inner surface of the tubular unit is annular similar to the annular portion, the annular portion can contact the inner surface of the tubular unit over a relatively wide area. Therefore, when the tubular unit contacts the annular portion, an impact applied from the annular portion to the tubular unit at this time is distributed, and the tubular unit can be prevented from being broken.

[0026] According to the eleventh aspect, in the tenth aspect, the annular portion has an outer peripheral surface that faces an inner surface of the tubular unit. The outer peripheral surface has such a tapering surface that an outer diameter is reducing as the outer peripheral surface extends toward a center of the tubular unit in the axial direction.

[0027] According to the eleventh aspect, insertion of the annular portion into the tubular unit can be facilitated when the annular portion is placed into the tubular unit.

[0028] According to a twelfth aspect, in any of the second to eleventh aspects, the first restriction unit includes an outer first restriction unit located outside the tubular unit.

[0029] According to the twelfth aspect, the outer first restriction unit is located outside the tubular unit, and therefore the tubular unit can move in the first direction and the outer first restriction unit can also restrict the movement of the tubular unit in the first direction even without a member for restricting the movement of the tubular unit provided inside the tubular unit. As a result, especially in the case where the containing unit is heated, due to the absence of a member for restricting the movement of the tubular unit at a position closer to the containing unit than the tubular unit is, the flavor inhaler suppresses transfer of the heat to the tubular unit and therefore can suppress dissipation of the heat of the containing unit to outside. In the case where the first restriction unit includes the inner first restriction unit and the outer first restriction unit, the movement of the tubular unit in the first

direction can be restricted by both the inner first restriction unit and the outer first restriction unit. More specifically, when the tubular unit moves in the first direction, both the inner first restriction unit and the outer first restriction unit can contact the tubular unit and restrict the movement of the tubular unit at the same time, and therefore an impact when the first restriction unit contacts the tubular unit is divided and the tubular unit can be prevented from being broken.

[0030] According to a thirteenth aspect, in the twelfth aspect according to any of the fourth to eleventh aspects, the inner first restriction unit and the outer first restriction unit are disposed at positions overlapping each other in the axial direction.

[0031] According to the thirteenth aspect, the movement of the tubular unit in the first direction can be restricted at the same axial position by both the inner first restriction unit and the outer first restriction unit. Therefore, when the first restriction unit contacts the tubular unit, an impact at this time is divided at the same axial position, and the tubular unit can be prevented from being broken.

[0032] According to a fourteenth aspect, in the thirteenth aspect, a space in the first direction is formed between the inner first restriction unit and the outer first restriction unit. The tubular unit is contained in the space.

[0033] According to the fourteenth aspect, the tubular unit is located in the space in the first direction, and can be held movably in the first direction in this space. In other words, the tubular unit is sandwiched without being fixed by the inner first restriction unit and the outer first restriction unit.

[0034] According to a fifteenth aspect, in any of the second to fourteenth aspects, the tubular unit includes a first end portion, and a second end portion opposite from the first end portion. The first restriction unit is disposed inside or outside at least one of the first end portion or the second end portion of the tubular unit in the first direction.

[0035] According to a sixteenth aspect, in the fifteenth aspect, the first restriction unit is disposed inside or outside both the first end portion and the second end portion of the tubular unit in the first direction.

[0036] According to the sixteenth aspect, the movement in the first direction can be restricted at two portions, the first end portion and the second end portion of the tubular unit, and therefore the tubular unit can be prevented from unlimitedly moving in the first direction at the both end portions of the tubular unit, thereby being further reliably prevented from colliding with another member (for example, the housing or the contained unit). Further, when the first restriction unit contacts the tubular unit, an impact at this time is divided to the both end portions, and the tubular unit can be prevented from being broken.

[0037] According to a seventeenth aspect, in any of the first to sixteenth aspects, the tubular unit includes a base portion and a heat insulation layer provided on an outer peripheral surface of the base portion.

[0038] According to the seventeenth aspect, the base

portion and the heat insulation layer can be prevented from being broken. Especially in the case where the heat insulation layer is made from a fragile material such as an aerogel sheet, the heat insulation layer is supported by the base portion, and the base portion can be held in such a manner that the holding unit is kept out of contact with the heat insulation layer.

[0039] According to an eighteenth aspect, in the seventeenth aspect according to the fourteenth aspect, the base portion includes a protrusion portion on one end of the tubular unit. The protrusion portion protrudes from the heat insulation layer in the axial direction. The protrusion portion is contained in the space.

[0040] According to the eighteenth aspect, a movement of the base portion constituting the tubular unit in the first direction is restricted by the inner first restriction unit and the outer first restriction unit. Therefore, the tubular unit can be prevented from being broken by making the base portion from, for example, a material having predetermined strength, such as resin such as PEEK.

[0041] According to a nineteenth aspect, in the seventeenth aspect according to any of the twelfth to fourteenth aspects, the outer first restriction unit is out of contact with the heat insulation layer.

[0042] According to the nineteenth aspect, no impact is directly applied from the outer first restriction unit to the heat insulation layer, and therefore the heat insulation layer can be prevented from being broken even when the heat insulation layer is made from a fragile material such as an aerogel sheet.

[0043] According to a twentieth aspect, in any of the first to nineteenth aspects, the containing unit includes a tubular sidewall portion. The sidewall portion includes a contact portion in contact with the consumable when the consumable is contained in the containing unit, and a separation portion located circumferentially adjacent to the contact portion and spaced apart from the consumable. An air flow path in communication with an end surface of the consumable in the containing unit and an opening of the containing unit is formed between the separation portion and the consumable when the consumable is contained in the containing unit.

[0044] According to the twentieth aspect, air supplied from the opening of the containing unit can reach inside a user's mouth via the air flow path and the end surface of the consumable, which eliminates the necessity of providing the flavor inhaler with an additional flow path for introducing the air to supply to the consumable, thereby contributing to simplification of the structure of the flavor inhaler.

[0045] According to a twenty-first aspect, any of the first to twentieth aspects includes a heating unit disposed on an outer periphery of the containing unit and configured to heat the consumable contained in the containing unit.

[0046] In the case where the consumable contained in the containing unit is heated, the tubular unit surrounding the contained unit may expand due to the heat of the

heating unit. According to the twenty-first aspect, even when the tubular unit expands due to the heat from the heating unit, the tubular unit can expand in the space in which the tubular unit is movable, and can be prevented from being subjected to a stress.

[0047] According to a twenty-second aspect, in any of the first to twenty-first aspects, the holding unit includes a second restriction unit configured to restrict a movement of the tubular unit in the axial direction, and is configured to hold the tubular unit movably in the axial direction.

[0048] According to the twenty-second aspect, while the tubular unit is movable in the axial direction, the movement thereof in the axial direction can be restricted by the second restriction unit. Therefore, the tubular unit can be prevented from unlimitedly moving in the axial direction, thereby being prevented from colliding with another member (for example, the housing or the contained unit).

BRIEF DESCRIPTION OF DRAWINGS

[0049]

Fig. 1A is a schematic front view of a flavor inhaler according to a present embodiment.

Fig. 1B is a schematic top view of the flavor inhaler according to the present embodiment.

Fig. 1C is a schematic bottom view of the flavor inhaler according to the present embodiment.

Fig. 2 is a schematic side cross-sectional view of a consumable.

Fig. 3 is a cross-sectional view of the flavor inhaler as viewed from arrows 3-3 illustrated in Fig. 1B.

Fig. 4A is a perspective view of a chamber.

Fig. 4B is a cross-sectional view of the chamber as viewed from arrows 4B-4B illustrated in Fig. 4A.

Fig. 5A is a cross-sectional view of the chamber as viewed from arrows 5A-5A illustrated in Fig. 4B.

Fig. 5B is a cross-sectional view of the chamber as viewed from arrows 5B-5B illustrated in Fig. 4B.

Fig. 6 is a perspective view of the chamber and a heating unit.

Fig. 7 is a cross-sectional view illustrated in Fig. 5B in a state that the consumable is placed at a desired position in the chamber.

Fig. 8 is an enlarged cross-sectional view of a first holding unit.

Fig. 9 is a cross-sectional view of a heat insulation unit taken along an X-Y plane.

Fig. 10 is a plan view of a ring.

Fig. 11 is a plan view of a heater cushion.

Fig. 12A is an enlarged cross-sectional view of a second holding unit.

Fig. 12B is an enlarged view of a portion A illustrated in Fig. 12A.

Fig. 13 is a plan view of a gasket as viewed from an annular portion side.

DESCRIPTION OF EMBODIMENTS

[0050] In the following description, an embodiment of the present invention will be described with reference to the drawings. In the drawings that will be described below, identical or corresponding components will be indicated by the same reference numerals, and redundant descriptions will be omitted.

[0051] Fig. 1A is a schematic front view of a flavor inhaler 100 according to the present embodiment. Fig. 1B is a schematic top view of the flavor inhaler 100 according to the present embodiment. Fig. 1C is a schematic bottom view of the flavor inhaler 100 according to the present embodiment. In the drawings that will be described in the present specification, an X-Y-Z orthogonal coordinate system may be set for convenience of the description. In this coordinate system, a Z axis extends vertically upward. An X-Y plane is laid so as to cut across the flavor inhaler 100 horizontally. A Y axis is disposed so as to extend from the front side to the back side of the flavor inhaler 100. The Z axis can also be said to be an insertion direction of a consumable contained in a chamber 50 of an atomization unit 30, which will be described below, or an axial direction of a tubular heat insulation unit. Further, the X axis can also be said to be a first direction perpendicular to the axial direction, and the Y axis can also be said to be a second direction perpendicular to the axial direction and the first direction. Further, the X-axis direction can also be said to be a device longitudinal direction in a plane perpendicular to the insertion direction of the consumable or a direction in which a heating unit and a power source unit are lined up. The Y-axis direction can also be said to be a device lateral direction in the plane perpendicular to the insertion direction of the consumable.

[0052] The flavor inhaler 100 according to the present embodiment is configured to, for example, generate an aerosol that contains a flavor by heating a stick-type consumable provided with a flavor source including an aerosol source.

[0053] As illustrated in Figs. 1A to 1C, the flavor inhaler 100 includes an outer housing 101 (corresponding to one example of a housing), a slide cover 102, and a switch unit 103. The outer housing 101 constitutes the outermost housing of the flavor inhaler 100, and is sized so as to be contained inside a user's hand. When the user uses the flavor inhaler 100, the user can inhale the aerosol while holding the flavor inhaler 100 with his/her hand. The outer housing 101 may be constructed by assembling a plurality of members. The outer housing 101 can be made from resin such as PEEK (polyetheretherketone).

[0054] The outer housing 101 includes a not-illustrated opening for receiving the consumable, and the slide cover 102 is slidably attached to the outer housing 101 so as to close this opening. More specifically, the slide cover 102 is configured movably along the outer surface of the outer housing 101 between a closing position (the position illustrated in Figs. 1A and 1B), at which the slide

cover 102 closes the above-described opening of the outer housing 101, and an opening position, at which the slide cover 102 opens the above-described opening. For example, the user can move the slide cover 102 to the closing position and the opening position by operating the slide cover 102 manually. Due to that, the side cover 102 can permit or restrict access of the consumable to inside the flavor inhaler 100.

[0055] The switch unit 103 is used to switch on and off the actuation of the flavor inhaler 100. For example, the user can cause power to be supplied from a not-illustrated power source to the not-illustrated heating unit and the heating unit to heat the consumable without burning it by operating the switch unit 103 in a state that the consumable is inserted in the flavor inhaler 100. The switch unit 103 may be a switch provided outside the outer housing 101 or may be a switch located inside the outer housing 101. In the case where the switch is located inside the outer housing 101, the switch is indirectly pressed by pressing of the switch unit 103 on the surface of the outer housing 101. The present embodiment will be described citing the example in which the switch of the switch unit 103 is located inside the outer housing 101.

[0056] The flavor inhaler 100 may further include a not-illustrated terminal. The terminal can be an interface that connects the flavor inhaler 100 to, for example, an external power source. In a case where the power source provided to the flavor inhaler 100 is a rechargeable battery, the external power source can supply a current to the power source to recharge the power source by being connected to the terminal. Further, the flavor inhaler 100 can be configured in such a manner that data relating to the actuation of the flavor inhaler 100 can be transmitted to an external apparatus by connecting a data transmission cable to the terminal.

[0057] Next, the consumable used in the flavor inhaler 100 according to the present embodiment will be described. Fig. 2 is a schematic side cross-sectional view of the consumable 110. In the present embodiment, a smoking system can be constituted by the flavor inhaler 100 and the consumable 110. In the example illustrated in Fig. 2, the consumable 110 includes a smokable substance 111, a tubular member 114, a hollow filter unit 116, and a filter unit 115. The smokable substance 111 is wrapped with first rolling paper 112. The tubular member 114, the hollow filter unit 116, and the filter unit 115 are wrapped with second rolling paper 113 different from the first rolling paper 112. The second rolling paper 113 is also wrapped around a part of the first rolling paper 112 wrapped around the smokable substance 111. As a result, the tubular member 114, the hollow filter unit 116, and the filter unit 115, and the smokable substance 111 are joined with each other. However, the second rolling paper 113 may be omitted, and the tubular member 114, the hollow filter unit 116, and the filter unit 115, and the smokable substance 111 may be joined with each other using the first rolling paper 112. A lip release agent 117, which is used to make it difficult for the user's lip to

stick to the second rolling paper 113, is applied to the outer surface near the end portion of the second rolling paper 113 on the filter unit 115 side. A portion of the consumable 110 to which the lip release agent 117 is applied functions as a mouthpiece of the consumable 110.

[0058] The smokable substance 111 can include the flavor source such as tobacco and the aerosol source. Further, the first rolling paper 112 wrapped around the smokable substance 111 can be a breathable sheet member. The tubular member 114 can be a paper tube or a hollow filter. The consumable 110 includes the smokable substance 111, the tubular member 114, the hollow filter unit 116, and the filter unit 115 in the illustrated example, but the configuration of the consumable 110 is not limited thereto. For example, the hollow filter unit 116 may be omitted, and the tubular member 114 and the filter unit 115 may be disposed adjacent to each other.

[0059] Next, the inner structure of the flavor inhaler 100 will be described. Fig. 3 is a cross-sectional view of the flavor inhaler 100 as viewed from arrows 3-3 illustrated in Fig. 1B. As illustrated in Fig. 3, an inner housing 10 (corresponding to one example of a housing) is provided inside the outer housing 101 of the flavor inhaler 100. The inner housing 10 is made from, for example, resin, and, especially, can be made from polycarbonate (PC), ABS (Acrylonitrile-Butadiene-Styrene) resin, PEEK (polyetheretherketone), a polymer alloy containing a plurality of kinds of polymers, or the like, or metal such as aluminum. The inner housing 10 is preferably made from PEEK from viewpoints of heat resistance and strength. However, the material of the inner housing 10 is not especially limited. A power source unit 20 and the atomization unit 30 are provided in an inner space of the inner housing 10. Further, the outer housing 101 is made from, for example, resin, and, especially, can be made from polycarbonate (PC), ABS (Acrylonitrile-Butadiene-Styrene) resin, PEEK (polyetheretherketone), a polymer alloy containing a plurality of kinds of polymers, or the like, or metal such as aluminum.

[0060] The power source unit 20 includes a power source 21. The power source 21 can be, for example, a rechargeable battery or a non-rechargeable battery. The power source 21 is electrically connected to the atomization unit 30. Due to that, the power source 21 can supply power to the atomization unit 30 so as to appropriately heat the consumable 110.

[0061] As illustrated, the atomization unit 30 includes a chamber 50 (corresponding to one example of a containing unit) extending in the insertion direction of the consumable 110 (the Z-axis direction), the heating unit 40 surrounding a part of the chamber 50, a heat insulation unit 32 (corresponding to one example of a tubular unit), and a substantially tubular insertion guide member 34. The chamber 50 is configured to contain the consumable 110. The heating unit 40 is configured to heat the consumable 110 contained in the chamber 50 in contact with the outer peripheral surface of the chamber 50. As illu-

strated, a bottom member 36 may be provided on the bottom portion of the chamber 50. The bottom member 36 can function as a stopper that positions the consumable 110 inserted in the chamber 50. The bottom member 36 has a recess/protrusion on a surface with which the consumable 110 is in abutment, and can define a space capable of supplying air to the surface with which the consumable 110 is in abutment. The bottom member 36 can be made from, for example, a resin material such as PEEK, metal, glass, or ceramic, but is not especially limited thereto. Further, the material for making the bottom member 36 may be a low thermally conductive member compared to the material for making the chamber 50. In a case where the bottom member 36 is joined with a bottom portion 56 of the chamber 50 (refer to Fig. 6B), an adhesive that can be made from a resin material such as epoxy resin or an inorganic material can be used therefor. The details of the chamber 50 and the heating unit 40 will be described below.

[0062] The heat insulation unit 32 is generally substantially tubular, and is disposed so as to surround the chamber 50. The heat insulation unit 32 can include, for example, an aerogel sheet. The insertion guide member 34 is made from a resin material such as PEEK, PC, or ABS, and is provided between the slide cover 102 located at the closing position and the chamber 50. In the present embodiment, the insertion guide member 34 can contact the chamber 50, and therefore the insertion guide member 34 is preferably made from PEEK from a viewpoint of heat resistance. When the slide cover 102 is located at the opening position, the insertion guide member 34 is in communication with outside the flavor inhaler 100, and guides insertion of the consumable 110 into the chamber 50 in reaction to insertion of the consumable 110 into the insertion guide member 34.

[0063] Next, the structure of the chamber 50 will be described. Fig. 4A is a perspective view of the chamber 50. Fig. 4B is a cross-sectional view of the chamber 50 as viewed from arrows 4B-4B illustrated in Fig. 4A. Fig. 5A is a cross-sectional view of the chamber 50 as viewed from arrows 5A-5A illustrated in Fig. 4B. Fig. 5B is a cross-sectional view of the chamber 50 as viewed from arrows 5B-5B illustrated in Fig. 4B. Fig. 6 is a perspective view of the chamber 50 and the heating unit 40. As illustrated in Figs. 4A and 4B, the chamber 50 can be a tubular member including an opening 52 via which the consumable 110 is inserted, and a tubular sidewall portion 60 containing the consumable 110. The chamber 50 is preferably made from a material heat-resisting and having a low coefficient of thermal expansion, and can be made from, for example, metal such as stainless steel, resin such as PEEK, glass, or ceramic.

[0064] As illustrated in Figs. 4B and 5B, the sidewall portion 60 includes a contact portion 62 and a separation portion 66. When the consumable 110 is placed at a desired position in the chamber 50, the contact portion 62 contacts or presses a part of the consumable 110, and the separation portion 66 is spaced apart from the con-

sumable 110. The "desired position in the chamber 50" in the present specification refers to a position at which the consumable 110 is appropriately heated or a position of the consumable 110 when the user smokes. The contact portion 62 has an inner surface 62a and an outer surface 62b. The separation portion 66 has an inner surface 66a and an outer surface 66b. As illustrated in Fig. 6, the heating unit 40 is disposed on the outer surface 62b of the contact portion 62. Preferably, the heating unit 40 is disposed on the outer surface 62b of the contact portion 62 without a space created therebetween. The heating unit 40 may include an adhesion layer. In this case, preferably, the heating unit 40 including the adhesion layer is disposed on the outer surface 62b of the contact portion 62 without a space created therebetween.

[0065] As illustrated in Figs. 4B and 5B, the outer surface 62b of the contact portion 62 is a flat surface. Since the outer surface 62b of the contact portion 62 is a flat surface, a band-shaped electrode 48 can be prevented from being deflected when the band-shaped electrode 48 is connected to the heating unit 40 disposed on the outer surface 62b of the contact portion 62 as illustrated in Fig. 6. As illustrated in Figs. 4B and 5B, the inner surface 62a of the contact portion 62 is a flat surface. Further, as illustrated in Figs. 4B and 5B, the contact portion 62 has an even thickness.

[0066] As illustrated in Figs. 4A, 4B, and 5B, the chamber 50 includes two contact portions 62 in the circumferential direction of the chamber 50, and the two contact portions 62 are located opposite from each other so as to extend in parallel with each other. Preferably, the distance between the inner surfaces 62a of the two contact portions 62 is at least partially shorter than the width of a portion of the consumable 110 inserted in the chamber 50 that is disposed between the contact portions 62.

[0067] As illustrated in Fig. 5B, the inner surface 66a of the separation portion 66 can have a generally circular arc-shaped cross-section in a plane perpendicular to the longitudinal direction of the chamber 50 (the Z-axis direction). Further, the separation portion 66 is disposed so as to be located circumferentially adjacent to the contact portion 62.

[0068] As illustrated in Fig. 4B, the chamber 50 can include a hole 56a on the bottom portion 56 thereof so as to allow the bottom member 36 illustrated in Fig. 3 to be disposed inside the chamber 50 while extending through the bottom portion 56. The bottom member 36 can be fixed inside the bottom portion 56 of the chamber 50 using an adhesive or the like. The bottom member 36 provided on the bottom portion 56 can support a part of the consumable 110 inserted in the chamber 50 in such a manner that the end surface of the consumable 110 is at least partially exposed. Further, the bottom portion 56 can support a part of the consumable 110 in such a manner that the exposed end surface of the consumable 110 is in communication with a space 67 (refer to Fig. 7), which will be described below.

[0069] As illustrated in Figs. 4A and 4B, preferably, the

chamber 50 includes a tubular portion 54 between the opening 52 and the sidewall portion 60. A space can be formed between the tubular portion 54 and the consumable 110 in the state that the consumable 110 is positioned at the desired position in the chamber 50. Further, as illustrated in Figs. 4A and 4B, preferably, the chamber 50 includes a first guide portion 58 having a tapering surface 58a connecting the inner surface of the tubular portion 54 and the inner surface 62a of the contact portion 62.

[0070] As illustrated in Fig. 6, the heating unit 40 includes a heating element 42. The heating element 42 may be, for example, a heating track. Preferably, the heating element 42 is disposed so as to heat the contact portion 62 without contacting the separation portion 66 of the chamber 50. In other words, preferably, the heating element 42 is disposed only on the outer surface of the contact portion 62. The heating element 42 may have a difference in heating capability between a portion that heats the separation portion 66 of the chamber 50 and a portion that heats the contact portion 62. More specifically, the heating element 42 may be configured to heat the contact portion 62 to a higher temperature than the separation portion 66. For example, the layout density of the heating track in the heating element 42 can be adjusted on the contact portion 62 and the separation portion 66. Alternatively, the heating element 42 may be wrapped around the outer periphery of the chamber 50 while keeping a substantially constant heating capability throughout the entire circumference of the chamber 50. As illustrated in Fig. 6, preferably, the heating unit 40 includes an electric insulation member 44 covering at least one surface of the heating element 42, in addition to the heating element 42. In the present embodiment, the electric insulation member 44 is disposed so as to cover the both surfaces of the heating element 42.

[0071] Fig. 7 is a cross-sectional view illustrated in Fig. 5B in the state that the consumable 110 is placed at the desired position in the chamber 50. As illustrated in Fig. 7, when the consumable 110 is placed at the desired position in the chamber 50, the consumable 110 can be pressed in contact with the contact portions 62 of the chamber 50. On the other hand, the space 67 is formed between the consumable 110 and each of the separation portions 66. The space 67 can be in communication with the opening 52 of the chamber 50 and the end surface of the consumable 110 positioned in the chamber 50. Due to that, air introduced via the opening 52 of the chamber 50 can flow into the consumable 110 by passing through the space 67. In other words, an air flow path (the space 67) is formed between the consumable 110 and the separation portion 66.

[0072] Next, how the heat insulation unit 32 is held according to the present embodiment will be described in detail. If the heat insulation unit 32 surrounding the chamber 50 is completely fixed to the inner housing 10 or the outer housing 101, the heat insulation unit 32 may be broken when an impact is applied to the flavor inhaler

100 from outside, due to a failure to buffer this impact. Further, if the heat insulation unit 32 expands due to the heat of the chamber 50 (or the heating unit 40), the fixed heat insulation unit may also be buckled due to the thermal expansion. In light thereof, in the present embodiment, the flavor inhaler 100 includes a first holding unit 37 and a second holding unit 38 (each corresponds to one example of a holding unit), which hold the heat insulation unit 32 movably in the axial direction of the chamber 50 or the first direction perpendicular to this axial direction (for example, the X-axis direction or the Y-axis direction). The first holding unit 37 and the second holding unit 38 will be described citing an example in which they hold the heat insulation unit 32 movably in the axial direction of the chamber 50 and the first direction in the present specification, but are not limited thereto and may hold the heat insulation unit 32 movably only in the axial direction or movably only in the first direction. Further, the first holding unit 37 and the second holding unit 38 can be made from, for example, elastomer such as silicone rubber.

[0073] As illustrated in Fig. 3, the first holding unit 37 holds a first end portion 39a of the heat insulation unit 32 on the terminal side (the Z-axis negative direction side) movably in the axial direction of the chamber 50 or the first direction. The second holding unit 38 holds a second end portion 39b of the heat insulation unit 32 on the slide cover 102 side (the Z-axis positive direction side) movably in the axial direction of the chamber 50 or the first direction. In other words, in the present embodiment, the heat insulation unit 32 is not completely fixed, and the flavor inhaler 100 includes a space for allowing the heat insulation unit 32 to move. Therefore, even if the heat insulation unit 32 expands due to the heat from the heating unit 40, the heat insulation unit 32 can expand in this space and therefore can be prevented from being buckled. Further, even if an impact is applied to the flavor inhaler 100 from outside, the heat insulation unit 32 can buffer the impact by moving and can be prevented from being broken.

[0074] Fig. 8 is an enlarged cross-sectional view of the first holding unit 37. As illustrated, the bottom member 36 provided inside the bottom portion 56 of the chamber 50 includes a shaft portion 36a protruding out of the chamber 50 via the hole 56a of the chamber 50. The flavor inhaler 100 includes a substantially tubular bottom member cap 72 that receives the shaft portion 36a of the bottom member 36. The bottom member cap 72 includes a flange portion 72a on one end thereof on the chamber 50 side.

[0075] The heat insulation unit 32 includes a support member 32a (corresponding to one example of a base portion) and a heat insulation layer 32b provided on the outer peripheral side of the support member 32a. Now, the outer peripheral side of the support member 32a refers to an opposite side from one side of the support member 32a that faces the chamber 50. The support member 32a is, for example, substantially tubular, and is disposed so as to surround the chamber 50. The support

member 32a can be made from resin such as PEEK, metal such as stainless steel, paper, glass, or the like. The support member 32a is not limited thereto, and can be made from any material capable of being tubularly shaped. The heat insulation layer 32b can be, for example, an aerogel sheet. In the present embodiment, the heat insulation layer 32b can be fixed to the outer surface of the support member 32a using an adhesive or the like. Further, the heat insulation layer 32b can be glued or fixed to the outer surface of the support member 32a via a PI (polyimide) substrate including silicon adhesion layers on the both sides thereof. The heat insulation unit 32 may further include a heat shrinkable tube 32c disposed on the outer surface of the heat insulation layer 32b. The shrinkable tube 32c can be made from, for example, thermoplastic resin such as PFA or FEP. The present embodiment employs the heat shrinkable tube 32c for the purpose of keeping the heat insulation layer 32b in a state in contact with the support member 32a, but can employ any member capable of serving a similar purpose without being limited thereto. For example, an elastic tube can be employed instead of the heat shrinkable tube 32c. A heat-resisting tape (for example, a PI tape) or a coating agent (for example, varnish) can be used as the elastic tube. As illustrated, in the present embodiment, the support member 32a may include a protrusion portion 33 axially protruding from the heat insulation layer 32b on one end of the heat insulation unit 32.

[0076] Fig. 9 is a cross-sectional view of the heat insulation unit 32 taken along the X-Y plane. As illustrated in Fig. 9, the support member 32a, the heat insulation layer 32b, and the heat shrinkable tube 32c constituting the heat insulation unit 32 are generally annular. The support member 32a has an inner diameter D_1 and an outer diameter D_4 . Further, the support member 32a has a circumferential length L_1 of the inner surface thereof. As illustrated, the heat insulation unit 32 is cylindrical in the present embodiment, but is not limited thereto and may have any shape such as a square tubular shape.

[0077] Referring to Fig. 8, the first holding unit 37 includes a ring 80 (corresponding to one example of a first restriction unit and an inner first restriction unit) and a heater cushion 74 (corresponding to one example of the first restriction unit and an outer first restriction unit). The ring 80 is located at a position axially overlapping the support member 32a of the heat insulation unit 32 and inside the support member 32a in the first direction. At least a part of the heater cushion 74, more specifically, a circumferential wall portion 75 illustrated in Fig. 11 is located at a position axially overlapping the support member 32a of the heat insulation unit 32 and outside the support member 32a in the first direction. The ring 80 and the heater cushion 74 hold the heat insulation unit 32 movably in the first direction while restricting a movement of the heat insulation unit 32 in the first direction by sandwiching the heat insulation unit 32 with a space created from the heat insulation unit 32. Therefore, the first holding unit 37 can prevent the heat insulation unit 32

from unlimitedly moving in the first direction, thereby preventing a collision between the heat insulation unit 32 and another member (for example, the inner housing 10 or the chamber 50).

[0078] Next, the details of the ring 80 will be described. Fig. 10 is a plan view of the ring 80. As illustrated in Figs. 8 and 10, the ring 80 includes an opening 80a in which the bottom member cap 72 is inserted, and can be fixed by being sandwiched between the flange portion 72a of the bottom member cap 72 and the heater cushion 74. As illustrated in Fig. 10, the ring 80 includes a ring main body 81, which defines the opening 80a, at least two (three in the illustrated example) protrusion portion 82, protrusion portion 83, and protrusion portion 84, which protrude from the ring main body 81 in a direction perpendicular to the axial direction of the chamber 50. The protrusion portion 83 and the protrusion portion 84 are provided at positions of -90° and $+90^\circ$, respectively, from the protrusion portion 82 in the circumferential direction with respect to the center of the opening 80a of the ring 80 in the plan view illustrated in Fig. 10. Further, as illustrated in Figs. 8 and 10, the ring 80 includes a cutout portion 85 for forming a space in which the electrode 48 of the heating unit 40 extends. The provision of the cutout portion 85 to the ring 80 allows the electrode 48 of the heating unit 40 to extend substantially in parallel with the axial direction.

[0079] The protrusion portion 82, the protrusion portion 83, and the protrusion portion 84 include a top portion 82a, a top portion 83a, and a top portion 84a shaped so as to conform with the inner surface of the support member 32a of the heat insulation unit 32 as viewed from the axial direction, i.e., in the plane illustrated in Fig. 10, respectively. Further, a diameter of an imaginary circle circumscribed around the protrusion portion 82, the protrusion portion 83, and the protrusion portion 84 of the ring 80 is a diameter D_{21} as viewed from the axial direction, i.e., in the plane illustrated in Fig. 10. In other words, this imaginary circle is circumscribed around the top portion 82a, the top portion 83a, and the top portion 84a.

[0080] Now, in the present embodiment, the diameter D_{21} of the imaginary circle circumscribed around the ring 80 is preferably smaller than the inner diameter D_1 of the support member 32a of the heat insulation unit 32 (i.e., $D_1 > D_{21}$ is preferable). In other words, a space is created between the ring 80 and the heat insulation unit 32 when the ring 80 is disposed inside the heat insulation unit 32. As a result, while the heat insulation unit 32 is movable in the first direction, the heat insulation unit 32 contacts the ring 80 by moving in the first direction and the movement of the heat insulation unit 32 in the first direction can be restricted by the ring 80.

[0081] Further, in the present embodiment, the protrusion portion 82, the protrusion portion 83, and the protrusion portion 84 of the ring 80 are circumscribed by the imaginary circle, and therefore these protrusion portion 82, protrusion portion 83, and protrusion portion 84 can contact the inner surface of the heat insulation unit 32 when the heat insulation unit 32 moves in the first direc-

tion. In other words, the ring 80 does not contact the inner surface of the heat insulation unit 32 throughout the entire circumference thereof. Therefore, compared to a configuration in which the ring 80 contacts the inner surface of the heat insulation unit 32 throughout the entire circumference thereof, the present embodiment can suppress transfer of the heat of the ring 80 to the heat insulation unit 32. Accordingly, especially in the case where the chamber 50 is heated, the present embodiment suppresses transfer of the heat to the heat insulation unit 32 from the ring 80 located closer to the chamber 50 than the heat insulation unit 32 is, thereby suppressing dissipation of the heat of the chamber 50 to outside as a result thereof.

[0082] Preferably, the difference between the inner diameter D1 and the diameter D21 is 1 mm or smaller. Due to that, the present embodiment allows the ring 80 to be substantially loosely fitted inside the heat insulation unit 32, and therefore can reduce the space required for the movement of the heat insulation unit 32 while the heat insulation unit 32 is movable in the first direction. As a result, the present embodiment can curb an increase in the size of the flavor inhaler 100. Further, because being able to reduce the range where the heat insulation unit 32 is movable, the present embodiment prevents the position of the heat insulation unit 32 from being largely misaligned from the designed layout position thereof in the flavor inhaler 100, thereby preventing the performance of the flavor inhaler 100 from deviating from the designed performance.

[0083] Assuming that a length L2 refers to the sum of the circumferential lengths of the top portion 82a, the top portion 83a, and the top portion 84a of the ring 80 (the lengths of portions thereof circumscribed by the imaginary circle of the ring 80), the length L2 is preferably smaller than the circumferential length L 1' (refer to Fig. 9) of the inner surface of the support member 32a of the heat insulation unit 32 (i.e., $L1' > L2$ is preferable). In other words, the ring 80 preferably does not contact the inner surface of the heat insulation unit 32 throughout the entire circumference thereof. In this case, compared to the configuration in which the ring 80 contacts the inner surface of the heat insulation unit 32 throughout the entire circumference thereof, the present embodiment can suppress transfer of the heat of the ring 80 to the heat insulation unit 32.

[0084] Further, assuming that a length L1 refers to the circumferential length of the imaginary circle circumscribed around the ring 80 illustrated in Fig. 10, the length L1 is preferably larger than the length L2, which is the sum of the circumferential lengths of the top portion 82a, the top portion 83a, and the top portion 84a of the ring 80 (the lengths of the portions thereof circumscribed by the imaginary circle of the ring 80), (i.e., $L1 > L2$ is preferable). This case leads to a reduction in the length of a portion along which the ring 80 is in proximity to the heat insulation unit 32 compared to a configuration in which the outer periphery of the ring 80 is circular in the planar view illustrated in Fig. 10, and therefore can suppress

transfer of the heat of the ring 80 to the heat insulation unit 32. Accordingly, especially in the case where the chamber 50 is heated, the present embodiment suppresses transfer of the heat to the heat insulation unit 32 from the ring 80 located closer to the chamber 50 than the heat insulation unit 32 is, thereby suppressing dissipation of the heat of the chamber 50 to outside as a result thereof.

[0085] Further preferably, the length L1 and the length L2 satisfy $L1 < 0.5 \times L2$. This configuration can further reduce the length of the portion along which the ring 80 is in proximity to the inner surface of the heat insulation unit 32. As a result, the present embodiment can further suppress the transfer of the heat of the ring 80 to the heat insulation unit 32. Further, most preferably, the length L1 and the length L2 satisfy $0.2 \times L2 < L1 < 0.4 \times L2$. If the length L1 is $0.2 \times L2$ or shorter, the ring 80 may be deformed and bring the axes (the central axes) of the chamber 50 and the heat insulation unit 32 out of alignment with each other. The length L1 equal to $0.2 \times L2$ and shorter than $0.4 \times L2$ allows the axial positions of the chamber 50 and the heat insulation unit 32 to be appropriately maintained while a heat leak can be further efficiently suppressed.

[0086] The ring 80 can restrict the movement of the heat insulation unit 32 in the first direction since the heat insulation unit 32 contacts the protrusion portion 82 when moving in the arbitrary first direction. Further, the ring 80 preferably restricts a movement in the second direction perpendicular to the axial direction and the first direction. More specifically, preferably, the ring 80 includes the protrusion portion 83 or the protrusion portion 84, and the protrusion portion 83 or the protrusion portion 84 contacts the heat insulation unit 32 to also restrict the movement in the second direction when the heat insulation unit 32 moves in the second direction perpendicular to the axial direction and this arbitrary first direction. Due to that, the present embodiment can prevent the heat insulation unit 32 from unlimitedly moving in the first direction and the second direction, thereby preventing a collision between the heat insulation unit 32 and another member (for example, the inner housing 10 or the chamber 50).

[0087] Further, since the ring 80 is located inside the heat insulation unit 32, the present embodiment can omit a space for providing a member for restricting the movement of the heat insulation unit 32 (for example, the heater cushion 74) outside the heat insulation unit 32, thereby curbing an increase in the size of the flavor inhaler 100.

[0088] Next, the heater cushion 74 will be described. Fig. 11 is a plan view of the heater cushion 74. The heater cushion 74 can be made of an elastic member such as rubber. As illustrated in Figs. 8 and 11, the heater cushion 74 includes a central recessed portion 74a, an annular protrusion portion 74b, a flat portion 74c, and the circumferential wall portion 75. The central recessed portion 74a is configured to contain and support one end of the bottom member cap 72. The annular protrusion portion

74b defines the central recessed portion 74a, and axially sandwiches the ring 80 together with the flange portion 72a of the bottom member cap 72.

[0089] The flat portion 74c extends from the annular protrusion portion 74b outward in the first direction while being spaced apart from the ring 80. The circumferential wall portion 75 extends from the outermost periphery of the flat portion 74c in the Z-axis positive direction, and is located on the outer peripheral side of the protrusion portion 33 of the support member 32a. As illustrated in Fig. 11, a diameter of an imaginary circle circumscribed around the inner surface of the circumferential wall portion 75 of the heater cushion 74 as viewed from the axial direction is a diameter D3. In the present embodiment, this diameter D3 is preferably larger than the outer diameter D4 of the support member 32a of the heat insulation unit 32 (i.e., $D3 > D4$ is preferable). In other words, a space is created between the support member 32a and the circumferential wall portion 75 when the support member 32a of the heat insulation unit 32 is disposed inside the circumferential wall portion 75 of the heater cushion 74. As a result, while the heat insulation unit 32 is movable in the first direction, the heat insulation unit 32 contacts the circumferential wall portion 75 by moving in the first direction and the movement of the heat insulation unit 32 in the first direction can be restricted by the heater cushion 74.

[0090] Preferably, the difference between the diameter D3 and the outer diameter D4 is 1 mm or smaller. Due to that, the present embodiment allows the support member 32a to be substantially loosely fitted inside the circumferential wall portion 75, and therefore can reduce a space required for the movement of the heat insulation unit 32 while the heat insulation unit 32 is movable in the first direction. As a result, the present embodiment can curb an increase in the size of the flavor inhaler 100. Further, because being able to reduce the range where the heat insulation unit 32 is movable, the present embodiment prevents the position of the heat insulation unit 32 from being largely misaligned from the designed layout position thereof in the flavor inhaler 100, thereby preventing the performance of the flavor inhaler 100 from deviating from the designed performance.

[0091] Due to the circumferential wall portion 75 of the heater cushion 74 located outside the heat insulation unit 32, the heat insulation unit 32 can move in the first direction and the circumferential wall portion 75 can also restrict the movement of the heat insulation unit 32 in the first direction even without a member for restricting the movement of the heat insulation unit 32 (for example, the ring 80) provided inside the heat insulation unit 32. Especially in the case where the chamber 50 is heated, a member for restricting the movement of the heat insulation unit 32 (for example, the ring 80) does not have to be provided at a position closer to the chamber 50 than the heat insulation unit 32 is. Therefore, the present embodiment suppresses transfer of the heat to the heat insulation unit 32 via this member, thereby suppressing dis-

sipation of the heat of the chamber 50 to outside as a result thereof.

[0092] Further, in the case where the ring 80 and the heater cushion 74 are provided like the present embodiment, the movement of the heat insulation unit 32 in the first direction can be restricted by both the ring 80 and the heater cushion 74. More specifically, when the heat insulation unit 32 moves in the first direction, both the ring 80 and the heater cushion 74 contact the heat insulation unit 32 at the same time and can restrict the movement of the heat insulation unit 32. Therefore, when the ring 80 and the heater cushion 74 contact the heat insulation unit 32, an impact at this time is divided and the heat insulation unit 32 can be prevented from being broken. The flavor inhaler 100 includes the ring 80 and the circumferential wall portion 75 of the heater cushion 74 in the present embodiment, but is not limited thereto and may be configured to include only any one of them.

[0093] Further, preferably, the ring 80 and the circumferential wall portion 75 of the heater cushion 74 are disposed at axially overlapping positions as illustrated in Fig. 8. Due to that, the movement of the heat insulation unit 32 in the first direction can be restricted at the same axial position by both the ring 80 and the heater cushion 74. Therefore, when the ring 80 and the heater cushion 74 contact the heat insulation unit 32, an impact at this time is divided at the same axial position, and the heat insulation unit 32 can be prevented from being broken.

[0094] Since the diameter D21 of the ring 80 is smaller than the diameter D3 of the imaginary circle of the circumferential wall portion 75, a space S1 in the first direction is formed between the ring 80 and the circumferential wall portion 75 of the heater cushion 74 as illustrated in Fig. 8. The protrusion portion 33 of the support member 32a is contained in this space S1. Therefore, the protrusion portion 33 of the support member 32a can be held in this space S1 movably in the first direction. In other words, the protrusion portion 33 of the support member 32a is sandwiched by the ring 80 and the circumferential wall portion 75 without being fixed thereto. Therefore, the heat insulation unit 32 can be prevented from being broken by making the support member 32a from, for example, a material having predetermined strength, such as resin such as PEEK.

[0095] Further, as illustrated in Fig. 8, the circumferential wall portion 75 is positioned so as to be out of contact with the heat insulation layer 32b of the heat insulation unit 32. Due to that, no impact is directly applied from the circumferential wall portion 75 to the heat insulation layer 32b, and therefore the heat insulation layer 32b can be prevented from being broken even when the heat insulation layer 32b is made from a fragile material such as an aerogel sheet.

[0096] The heater cushion 74 may include an end surface support portion 76 that can contact the end surface of the protrusion portion 33 of the support member 32a. As will be described below, the end surface support portion 76 of the heater cushion 74 can hold the heat

insulation unit 32 axially movably in cooperation with a gasket 90 of the second holding unit 38.

[0097] Fig. 12A is an enlarged cross-sectional view of the second holding unit 38. Fig. 12B is an enlarged view of a portion A illustrated in Fig. 12A. As illustrated in Fig. 12A, the second holding unit 38 includes the gasket 90 disposed around the tubular portion 54 of the chamber 50 in the present embodiment. The gasket 90 includes an annular portion 92, which is disposed between the chamber 50 and the heat insulation unit 32 as viewed from the axial direction (the Z-axis direction), and a flange portion 90a, which has a larger outer diameter than the annular portion 92. Then, "between the chamber 50 and the heat insulation unit 32" means a space in the first direction between the chamber 50 and the heat insulation unit 32, and "disposed between the chamber 50 and the heat insulation unit 32" means being located so as to overlap the chamber 50 and the heat insulation unit 32 in the axial direction (the Z-axis direction) and sandwiched between the chamber 50 and the heat insulation unit 32. The annular portion 92 has an outer peripheral surface 92a that faces the inner surface of the heat insulation unit 32, i.e., the inner surface of the support member 32a.

[0098] Fig. 13 is a plan view of the gasket 90 as viewed from the annular portion 92 side. Assume that a diameter D22 refers to a diameter of an imaginary circle circumscribed around the outer peripheral surface 92a of the annular portion 92 as illustrated in Fig. 13. Now, in the present embodiment, this diameter D22 is preferably smaller than the inner diameter D1 (refer to Fig. 9) of the support member 32a of the heat insulation unit 32 (i.e., $D1 > D22$ is preferable). In other words, a space is created between the annular portion 92 and the heat insulation unit 32 when the annular portion 92 is disposed inside the heat insulation unit 32. As a result, while the heat insulation unit 32 is movable in the first direction, the heat insulation unit 32 contacts the outer peripheral surface 92a of the annular portion 92 by moving in the first direction and the movement of the heat insulation unit 32 in the first direction can be restricted by the annular portion 92. Further, in the case where the cross-sectional shape of the inner surface of the heat insulation unit 32 is annular similar to the annular portion 92 like the present embodiment, the annular portion 92 can contact the inner surface of the heat insulation unit 32 over a relatively wide area. Therefore, when the heat insulation unit 32 contacts the annular portion 92, an impact applied from the annular portion 92 to the heat insulation unit 32 at this time is distributed, and the heat insulation unit 32 can be prevented from being broken.

[0099] Preferably, the difference between the inner diameter D1 and the diameter D22 is 1 mm or smaller. Due to that, the present embodiment allows the annular portion 92 of the gasket 90 to be substantially loosely fitted inside the heat insulation unit 32, and therefore can reduce a space required for the movement of the heat insulation unit 32 while the heat insulation unit 32 is movable in the first direction. As a result, the present

embodiment can curb an increase in the size of the flavor inhaler 100. Further, because being able to reduce the range where the heat insulation unit 32 is movable, the present embodiment prevents the position of the heat insulation unit 32 from being largely misaligned from the designed layout position thereof in the flavor inhaler 100, thereby preventing the performance of the flavor inhaler 100 from deviating from the designed performance.

[0100] Further, preferably, the outer peripheral surface 92a of the annular portion 92 includes such a tapering surface 92a that an outer diameter thereof is reducing as the outer peripheral surface 92a extends toward the central portion of the chamber 50 in the axial direction as illustrated in Figs. 12A and 12B. This can facilitate insertion of the annular portion 92 into the heat insulation unit 32 when the annular portion 92 is disposed inside the heat insulation unit 32.

[0101] Further, in the present embodiment, the flange portion 90a of the gasket 90 can contact the end surface of the support member 32a of the heat insulation unit 32 as illustrated in Fig. 12A. As illustrated in Fig. 12B, the support member 32a protrudes toward the flange portion 90a slightly beyond the heat insulation layer 32b. Therefore, the present embodiment is configured in such a manner that the flange portion 90a is kept out of contact with the heat insulation layer 32b when the flange portion 90a contacts the support member 32a. This flange portion 90a of the gasket 90 and the end surface support portion 76 of the heater cushion 74 illustrated in Fig. 8 can hold the heat insulation unit 32 axially movably and restrict an axial movement of the heat insulation unit 32. More specifically, the gasket 90 and the heater cushion 74 are positioned in such a manner that an axial distance L3 between the flange portion 90a and the end surface support portion 76 of the heater cushion 74 exceeds an axial length L4 of the support member 32a of the heat insulation unit 32. In other words, the distance $L3 > L4$ can be established in the present embodiment. In the state illustrated in Fig. 12B, the support member 32a is supported in contact with the end surface support portion 76 of the heater cushion 74 illustrated in Fig. 8, and therefore a slight space is formed between the support member 32a and the flange portion 90a. Accordingly, the heat insulation unit 32 can axially move between the flange portion 90a of the gasket 90 and the end surface support portion 76 of the heater cushion 74. Further, the axial movement of the heat insulation unit 32 is restricted by the flange portion 90a and the end surface support portion 76. Due to that, the present embodiment can prevent the heat insulation unit 32 from unlimitedly axially moving, thereby preventing a collision between the heat insulation unit 32 and another member (for example, the inner housing 10 or the chamber 50).

[0102] On the other hand, the gasket 90 and the heater cushion 74 may be positioned in such a manner that the axial distance between the flange portion 90a and the end surface support portion 76 of the heater cushion 74

substantially matches the axial length of the support member 32a of the heat insulation unit 32. In this case, the both ends of the support member 32a of the heat insulation unit 32 contact both the flange portion 90a and the end surface support portion 76, respectively. Even in this case, the heat insulation unit 32 is movable in the first direction although a frictional force is applied from the flange portion 90a and the end surface support portion 76 to the support member 32a.

[0103] In the present embodiment, the ring 80 is disposed inside the first end portion 39a of the heat insulation unit 32 and the circumferential wall portion 75 of the heater cushion 74 is disposed outside the first end portion 39a, and the gasket 90 is disposed inside the second end portion 39b of the heat insulation unit 32. Due to that, the movement of the heat insulation unit 32 in the first direction can be restricted at two portions, the first end portion 39a and the second end portion 39b of the heat insulation unit 32. Therefore, the present embodiment can prevent the heat insulation unit 32 from unlimitedly moving in the first direction at the both end portions of the heat insulation unit 32, thereby further reliably preventing a collision between the heat insulation unit 32 and another member (for example, the inner housing 10 or the chamber 50). Further, when the ring 80, the heater cushion 74, or the gasket 90 contacts the heat insulation unit 32, an impact at this time is divided to the both end portions, and the heat insulation unit 32 can be prevented from being broken. However, without being limited thereto, a member for restricting the movement of the heat insulation unit 32 in the first direction may be provided on at least one of the inner side or the outer side of only any one of the first end portion 39a and the second end portion 39b of the heat insulation unit 32.

[0104] Having described the embodiment of the present invention, the present invention shall not be limited to the above-described embodiment, and various modifications are possible within the scope of the technical idea disclosed in the claims, specification, and drawings. Note that any shape and material not directly described or illustrated in the specification and drawings are still within the scope of the technical idea of the present invention insofar as they allow the present invention to achieve the actions and effects thereof. For example, the flavor inhaler 100 according to the present embodiment includes a so-called counterflow-type air flow path in which the air introduced via the opening 52 of the chamber 50 is supplied to the end surface of the consumable 110, but is not limited thereto and may include a so-called bottom flow-type air flow path in which air is supplied from the bottom portion 56 of the chamber 50 into the chamber 50. Further, the heating element 42 is not limited to the resistance heating-type element and may be an induction heating-type element. In this case, the heating element 42 can heat the chamber 50 by induction heating. Further, in a case where the consumable 110 includes a susceptor, the heating element 42 can heat the susceptor of the consumable 110 by induction heating.

REFERENCE SIGNS LIST

[0105]

5	10	inner housing
	32	heat insulation unit
	32a	support member
	32b	heat insulation layer
	33	protrusion portion
10	37	first holding unit
	38	second holding unit
	39a	first end portion
	39b	second end portion
	40	heating unit
15	42	heating element
	50	chamber
	60	sidewall portion
	62	contact portion
	66	separation portion
20	67	space
	74	heater cushion
	75	circumferential wall portion
	76	end surface support portion
	80	ring
25	82	protrusion portion
	82a	top portion
	83	protrusion portion
	83a	top portion
	84	protrusion portion
30	84a	top portion
	90	gasket
	90a	flange portion
	92	annular portion
	92a	outer peripheral surface
35	100	flavor inhaler
	101	outer housing
	110	consumable
	D1	inner diameter
	D2	diameter
40	D3	outer diameter
	S1	space

Claims

- 45 1. A flavor inhaler (100) comprising:
- 50 a housing (10);
a chamber (50) contained in the housing (10) and including a first opening (52) via which a consumable (110) is to be inserted and a tubular sidewall portion (60) adapted to contain the consumable (110);
55 a heat insulation unit (32) including a first end portion (39a), and a second end portion (39b) opposite from the first end portion (39a), and surrounding the chamber (50), the first end portion (39a) being positioned on the Z-axis negative direction side and the second end portion

- (39b) being positioned on the Z-axis positive side, the Z-axis positive direction being opposite to an insertion direction of the consumable (110); and
 a first holding unit (37) holding the first end portion (39a) of the heat insulation unit (32), the first holding unit (37) including an inner first restriction unit located inside the heat insulation unit and an outer first restriction unit located outside the heat insulation unit,
 wherein the heat insulation unit (32) includes a base portion (32a) and a heat insulation layer (32b) provided on an outer peripheral side of the base portion (32), **characterized in that** the base portion (32a) includes a protrusion portion (33) on one end of the heat insulation unit (32), the protrusion portion (33) protruding from the heat insulation layer (32b) in the axial direction,
 a space in a first direction perpendicular to the axial direction is formed between the inner first restriction unit and the outer first restriction unit, the protrusion portion is contained in the space, and
 the first holding unit (37) holds the base portion (32a) of the heat insulation unit (32) so as to be out of contact with the heat insulation layer (32b).
2. The flavor inhaler (100) according to claim 1, wherein a heater cushion (74) of the first holding unit (37) includes an end surface support portion (76) that contacts the end surface of the protrusion portion (33).
 3. The flavor inhaler (100) according to claim 1 or 2, further comprising a second holding unit (38) holding the second end portion (39b) of the heat insulation unit (32), wherein the second end portion (39b) includes a gasket (90) which is disposed around a tubular unit (54) of the chamber (50) and includes an annular portion (92), which is disposed between the chamber (50) and the heat insulation unit (32), as viewed from the axial direction, and a flange portion (90a), which has a larger outer diameter than the annular portion (92).
 4. The flavor inhaler (100) according to claim 3, wherein an outer peripheral surface (92a) of the annular portion (92) includes a tapering surface (92a) that an outer diameter thereof is reducing as the outer peripheral surface (92a) extends toward a central portion of the chamber (50) in the axial direction.
 5. The flavor inhaler (100) according to claim 3 or 4, wherein the base portion (32a) protrudes toward the flange portion (90a) slightly beyond the heat insula-
- tion layer (32b).
6. The flavor inhaler (100) according to any one of claims 3 - 5 depending from claim 2, wherein an axial distance between the flange portion (90a) and the end surface support portion (76) of the heater cushion (74) exceeds an axial length of the base portion (32a).
 7. The flavor inhaler (100) according to any one of claims 1 - 6, wherein the heat insulation layer (32b) includes an aerogel sheet.
 8. The flavor inhaler (100) according to any one of claims 1 - 7, wherein the chamber (50) is made from metal.
 9. The flavor inhaler (100) according to any one of claims 1 - 8, wherein the heat insulation unit (32) includes a shrinkable tube made from thermoplastic resin disposed on the outer surface of the heat insulation layer (32b).
 10. The flavor inhaler (100) according to any one of claims 1 - 9, wherein the first holding unit (37) includes a ring located at a position axially overlapping the base portion (32a) and inside the base portion (32a) in the first direction.
 11. The flavor inhaler (100) according to any one of claims 1 - 10, further comprising a bottom member (36) provided on a bottom portion (56) of the chamber (50), wherein the chamber (50) and the bottom member (36) are made from different members.
 12. The flavor inhaler (100) according to claim 11, wherein the bottom member (36) includes a shaft portion (36a) protruding from the bottom portion (56) of the chamber (50), and the flavor inhaler (100) includes a tubular member (72) that receives the shaft portion (36a).
 13. The flavor inhaler (100) according to any one of claims 1 - 10, further comprising a bottom member (36) provided on a bottom portion (56) of the chamber (50), wherein the chamber (50) includes a second opening (56a) on the bottom portion (56) thereof.
 14. The flavor inhaler (100) according to any one of claims 1 - 13, wherein the chamber (50) is spaced apart from the heat insulation unit (32) in a direction perpendicular to the axial direction.
 15. The flavor inhaler (100) according to any one of claims 1 - 14, wherein an atomization unit (30) is provided in an inner space of the housing (10), the

atomization unit (30) including the chamber (50) and a heating unit (40), the heating unit (40) including a heating element (42), and the heating element (42) being an induction heating type element.

16. A smoking system comprising the flavor inhaler (100) according to any one of claims 1 - 15, and a consumable (110).

Patentansprüche

1. Aromainhalator (100), umfassend:

ein Gehäuse (10);
 eine Kammer (50), die im Gehäuse (10) enthalten ist und eine erste Öffnung (52), über die ein Verbrauchsmaterial (110) einzuführen ist, und einen röhrenförmigen Seitenwandabschnitt (60) einschließt, der zum Aufnehmen des Verbrauchsmaterials (110) angepasst ist;
 eine Wärmeisolationseinheit (32), die einen ersten Endabschnitt (39a) und einen dem ersten Endabschnitt (39a) gegenüberliegenden zweiten Endabschnitt (39b) einschließt, und die Kammer (50) umgibt, wobei der erste Endabschnitt (39a) auf der Seite der negativen Z-Achsenrichtung positioniert ist und der zweite Endabschnitt (39b) auf der Seite der positiven Z-Achse positioniert ist, wobei die positive Z-Achsenrichtung entgegengesetzt zu einer Einführrichtung des Verbrauchsmaterials (110) ist; und eine erste Halteeinheit (37), die den ersten Endabschnitt (39a) der Wärmeisolationseinheit (32) hält, wobei die erste Halteeinheit (37) eine innere erste Begrenzungseinheit, die sich innerhalb der Wärmeisolationseinheit befindet, und eine äußere erste Begrenzungseinheit einschließt, die sich außerhalb der Wärmeisolationseinheit befindet, wobei die Wärmeisolationseinheit (32) einen Basisabschnitt (32a) und eine Wärmeisolationsschicht (32b) einschließt, die an einer äußeren Umfangsseite des Basisabschnitts (32) vorgesehen ist, **dadurch gekennzeichnet, dass** der Basisabschnitt (32a) an einem Ende der Wärmeisolationseinheit (32) einen Vorsprungsabschnitt (33) einschließt, wobei der Vorsprungsabschnitt (33) in der axialen Richtung von der Wärmeisolationsschicht (32b) vorsteht, zwischen der inneren ersten Begrenzungseinheit und der äußeren ersten Begrenzungseinheit ein Raum in einer ersten Richtung senkrecht zur Axialrichtung ausgebildet ist, der Vorsprungsabschnitt in dem Raum enthalten ist, und die erste Halteeinheit (37) den Basisabschnitt (32a) der Wärmeisolationseinheit (32) hält, so

dass sie keinen Kontakt mit der Wärmeisolationsschicht (32b) hat.

2. Aromainhalator (100) nach Anspruch 1, wobei ein Heizkissen (74) der ersten Halteeinheit (37) einen Endflächen-Stützabschnitt (76) einschließt, der die Endfläche des Vorsprungsabschnitts (33) berührt.
3. Aromainhalator (100) nach Anspruch 1 oder 2, weiter umfassend eine zweite Halteeinheit (38), die den zweiten Endabschnitt (39b) der Wärmeisolationseinheit (32) hält, wobei die zweite Endabschnitt (39b) eine Dichtung (90) einschließt, die um eine röhrenförmige Einheit (54) der Kammer (50) angeordnet ist und einen ringförmigen Abschnitt (92) einschließt, der von der axialen Richtung aus gesehen zwischen der Kammer (50) und der Wärmeisolationseinheit (32) angeordnet ist, und einen Flanschabschnitt (90a) einschließt, der einen größeren Außendurchmesser als der ringförmige Abschnitt (92) aufweist.
4. Aromainhalator (100) nach Anspruch 3, wobei eine äußere Umfangsfläche (92a) des ringförmigen Abschnitts (92) eine sich verjüngende Oberfläche (92a) einschließt, deren Außendurchmesser sich verringert, wenn sich die äußere Umfangsfläche (92a) in der axialen Richtung in Richtung eines zentralen Abschnitts der Kammer (50) erstreckt.
5. Aromainhalator (100) nach Anspruch 3 oder 4, wobei der Basisabschnitt (32a) in Richtung des Flanschabschnitts (90a) geringfügig über die Wärmeisolationsschicht (32b) hinausragt.
6. Aromainhalator (100) nach einem der Ansprüche 3 - 5, in Abhängigkeit von Anspruch 2, wobei ein axialer Abstand zwischen dem Flanschabschnitt (90a) und dem Endflächen-Stützabschnitt (76) des Heizkissens (74) eine axiale Länge des Basisabschnitts (32a) überschreitet.
7. Aromainhalator (100) nach einem der Ansprüche 1 - 6, wobei die Wärmeisolationsschicht (32b) eine Aerogelfolie einschließt.
8. Aromainhalator (100) nach einem der Ansprüche 1 - 7, wobei die Kammer (50) aus einem Metall hergestellt ist.
9. Aromainhalator (100) nach einem der Ansprüche 1 - 8, wobei die Wärmeisolationseinheit (32) einen Schrumpfschlauch, hergestellt aus thermoplastischem Harz, einschließt, der auf der äußeren Oberfläche der Wärmeisolationsschicht (32b) angeordnet ist.
10. Aromainhalator (100) nach einem der Ansprüche 1 -

- 9, wobei die erste Halteeinheit (37) einen Ring einschließt, der sich an einer Position befindet, die den Basisabschnitt (32a) axial überlappt und sich in der ersten Richtung innerhalb des Basisabschnitts (32a) befindet. 5
11. Aromainhalator (100) nach einem der Ansprüche 1 - 10, weiter umfassend ein Bodenelement (36), das an einem Bodenabschnitt (56) der Kammer (50) vorgesehen ist, wobei die Kammer (50) und das Bodenelement (36) aus unterschiedlichen Elementen hergestellt sind. 10
12. Aromainhalator (100) nach Anspruch 11, wobei das Bodenelement (36) einen Schaftabschnitt (36a) einschließt, der aus dem Bodenabschnitt (56) der Kammer (50) herausragt, und der Aromainhalator (100) ein röhrenförmiges Element (72) einschließt, das den Schaftabschnitt (36a) aufnimmt. 20
13. Aromainhalator (100) nach einem der Ansprüche 1 - 10, weiter umfassend ein Bodenelement (36), das an einem Bodenabschnitt (56) der Kammer (50) vorgesehen ist, wobei die Kammer (50) eine zweite Öffnung (56a) an ihrem Bodenabschnitt (56) einschließt. 25
14. Aromainhalator (100) nach einem der Ansprüche 1 - 13, wobei die Kammer (50) in einer Richtung senkrecht zur Axialrichtung von der Wärmeisolationseinheit (32) beabstandet ist. 30
15. Aromainhalator (100) nach einem der Ansprüche 1 - 14, wobei in einem Innenraum des Gehäuses (10) eine Zerstäubungseinheit (30) vorgesehen ist, wobei die Zerstäubungseinheit (30) die Kammer (50) und eine Heizeinheit (40) einschließt, wobei die Heizeinheit (40) ein Heizelement (42) einschließt, wobei das Heizelement (42) ein Element vom Induktionsheiztyp ist. 35
16. Rauchsystem, umfassend den Aromainhalator (100) nach einem der Ansprüche 1 - 15, und ein Verbrauchsmaterials (110). 40

Revendications

1. Inhalateur (100) d'arôme comprenant : 50
- un boîtier (10) ;
 - une chambre (50) contenue dans le boîtier (10) et incluant une première ouverture (52) par laquelle un consommable (110) doit être inséré et une partie (60) de paroi latérale tubulaire adaptée pour contenir le consommable (110) ; 55
 - une unité (32) d'isolation thermique incluant une

première partie (39a) d'extrémité, et une seconde partie (39b) d'extrémité opposée à la première partie (39a) d'extrémité, et entourant la chambre (50), la première partie (39a) d'extrémité étant positionnée du côté direction négative de l'axe Z et la seconde partie (39b) d'extrémité étant positionnée du côté positif de l'axe Z, la direction positive de l'axe Z étant opposée à une direction d'insertion du consommable (110) ; et

une première unité (37) de maintien maintenant la première partie (39a) d'extrémité de l'unité (32) d'isolation thermique, la première unité (37) de maintien incluant une première unité de restriction intérieure située à l'intérieur de l'unité d'isolation thermique et une première unité de restriction extérieure située à l'extérieur de l'unité d'isolation thermique,

dans lequel l'unité (32) d'isolation thermique inclut une partie (32a) de base et une couche (32b) d'isolation thermique prévue sur un côté périphérique extérieur de la partie (32) de base, **caractérisé en ce que**

la partie (32a) de base inclut une partie (33) de saillie sur une extrémité de l'unité (32) d'isolation thermique, la partie (33) de saillie faisant saillie de la couche (32b) d'isolation thermique dans la direction axiale,

un espace dans une première direction perpendiculaire à la direction axiale est formé entre la première unité de restriction intérieure et la première unité de restriction extérieure,

la partie de saillie est contenue dans l'espace, et la première unité (37) de maintien maintient la partie (32a) de base de l'unité (32) d'isolation thermique de façon à ce qu'elle soit hors de contact avec la couche (32b) d'isolation thermique.

2. Inhalateur (100) d'arôme selon la revendication 1, dans lequel un coussin (74) chauffant de la première unité (37) de maintien inclut une partie (76) de support de surface d'extrémité qui entre en contact avec la surface d'extrémité de la partie (33) de saillie.
3. Inhalateur (100) d'arôme selon la revendication 1 ou la revendication 2, comprenant en outre une seconde unité (38) de maintien maintenant la seconde partie (39b) d'extrémité de l'unité (32) d'isolation thermique, dans lequel la seconde partie (39b) d'extrémité inclut un joint (90) d'étanchéité qui est disposé autour d'une unité (54) tubulaire de la chambre (50) et inclut une partie (92) annulaire, qui est disposée entre la chambre (50) et l'unité (32) d'isolation thermique, vu depuis la direction axiale, et une partie (90a) de bride, qui a un diamètre extérieur plus grand que la partie (92) annulaire.

4. Inhalateur (100) d'arôme selon la revendication 3, dans lequel une surface (92a) périphérique extérieure de la partie (92) annulaire inclut une surface (92a) d'effilement dont un diamètre extérieur se réduit à mesure que la surface (92a) périphérique extérieure s'étend vers une partie (50) centrale de la chambre dans la direction axiale. 5
5. Inhalateur (100) d'arôme selon la revendication 3 ou la revendication 4, dans lequel la partie (32a) de base fait saillie vers la partie (90a) de bride légèrement au-delà de la couche (32b) d'isolation thermique. 10
6. Inhalateur (100) d'arôme selon l'une quelconque des revendications 3 à 5 lorsqu'elles dépendent de la revendication 2, dans lequel une distance axiale entre la partie (90a) de bride et la partie (76) de support de surface d'extrémité du coussin (74) chauffant dépasse une longueur axiale de la partie (32a) de base. 15 20
7. Inhalateur (100) d'arôme selon l'une quelconque des revendications 1 à 6, dans lequel la couche (32b) d'isolation thermique inclut une feuille d'aérogel. 25
8. Inhalateur (100) d'arôme selon l'une quelconque des revendications 1 à 7, dans lequel la chambre (50) est constituée de métal. 30
9. Inhalateur (100) d'arôme selon l'une quelconque des revendications 1 à 8, dans lequel l'unité (32) d'isolation thermique inclut un tube rétractable constitué de résine thermoplastique disposé sur la surface extérieure de la couche (32b) d'isolation thermique. 35
10. Inhalateur (100) d'arôme d'arôme selon l'une quelconque des revendications 1 à 9, dans lequel la première unité (37) de maintien inclut une bague située à une position chevauchant axialement la partie (32a) de base et à l'intérieur de la partie (32a) de base dans la première direction. 40 45
11. Inhalateur (100) d'arôme selon l'une quelconque des revendications 1 à 10, comprenant en outre un organe (36) bas prévu sur une partie (56) basse de la chambre (50), dans lequel la chambre (50) et l'organe (36) bas sont constitués d'organes différents. 50
12. Inhalateur (100) d'arôme selon la revendication 11, dans lequel l'organe (36) bas inclut une partie (36a) d'arbre faisant saillie de la partie (56) basse de la chambre (50), et l'inhalateur (100) d'arôme inclut un organe (72) tubulaire qui reçoit la partie (36a) d'arbre. 55
13. Inhalateur (100) d'arôme selon l'une quelconque des revendications 1 à 10, comprenant en outre un organe (36) bas prévu sur une partie (56) basse de la chambre (50), dans lequel la chambre (50) inclut une seconde ouverture (56a) sur sa partie (56) basse. 5
14. Inhalateur (100) d'arôme selon l'une quelconque des revendications 1 à 13, dans lequel la chambre (50) est espacée de l'unité (32) d'isolation thermique dans une direction perpendiculaire à la direction axiale. 10
15. Inhalateur (100) d'arôme selon l'une quelconque des revendications 1 à 14, dans lequel une unité (30) d'atomisation est prévue dans un espace intérieur du boîtier (10), l'unité (30) d'atomisation incluant la chambre (50) et une unité (40) chauffante, l'unité (40) chauffante incluant un élément (42) chauffant, et l'élément (42) chauffant étant un élément de type chauffant par induction. 15 20
16. Système à fumer comprenant l'inhalateur (100) d'arôme selon l'une quelconque des revendications 1 à 15, et un consommable (110). 25

Fig. 1A

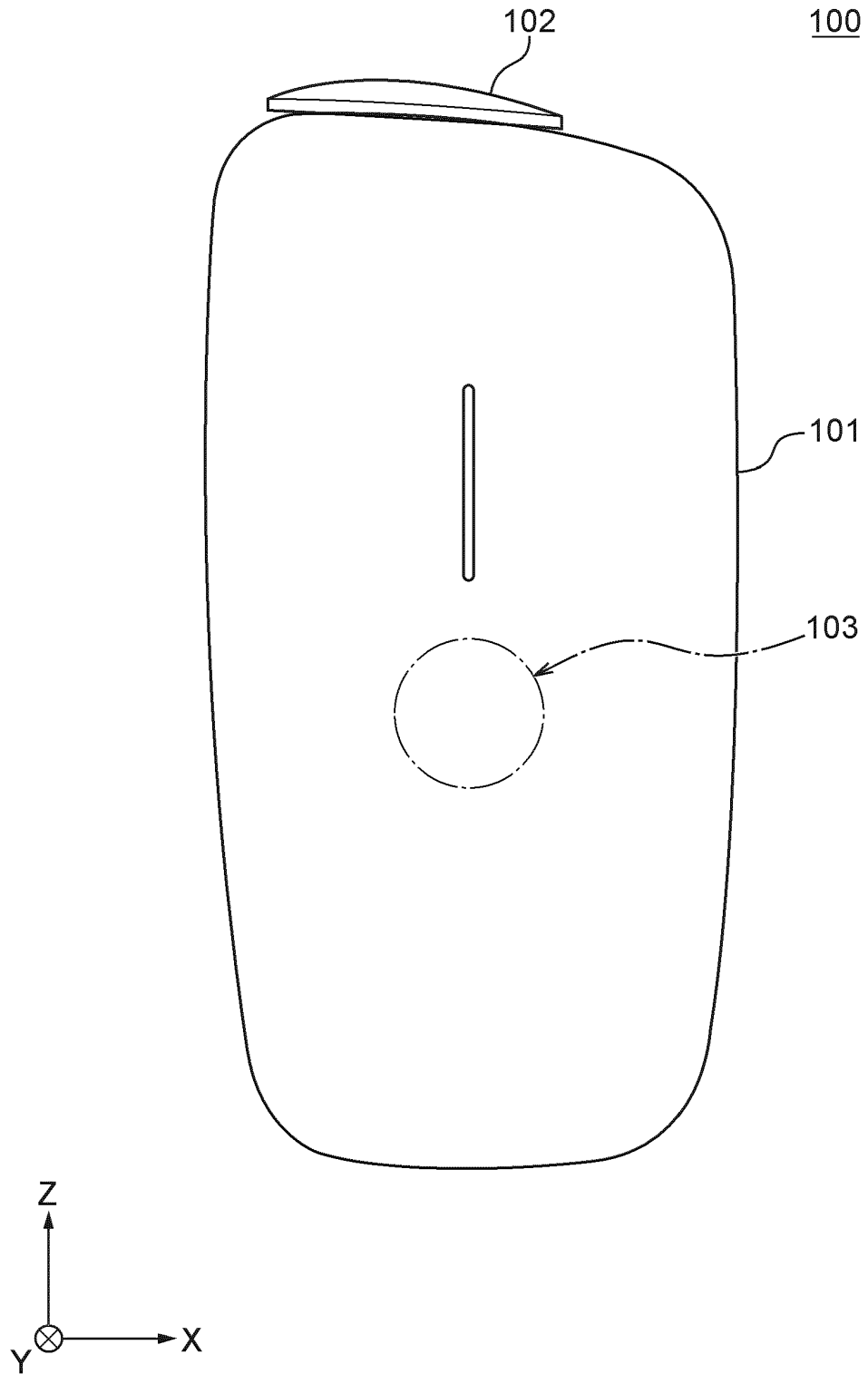

Fig. 1B

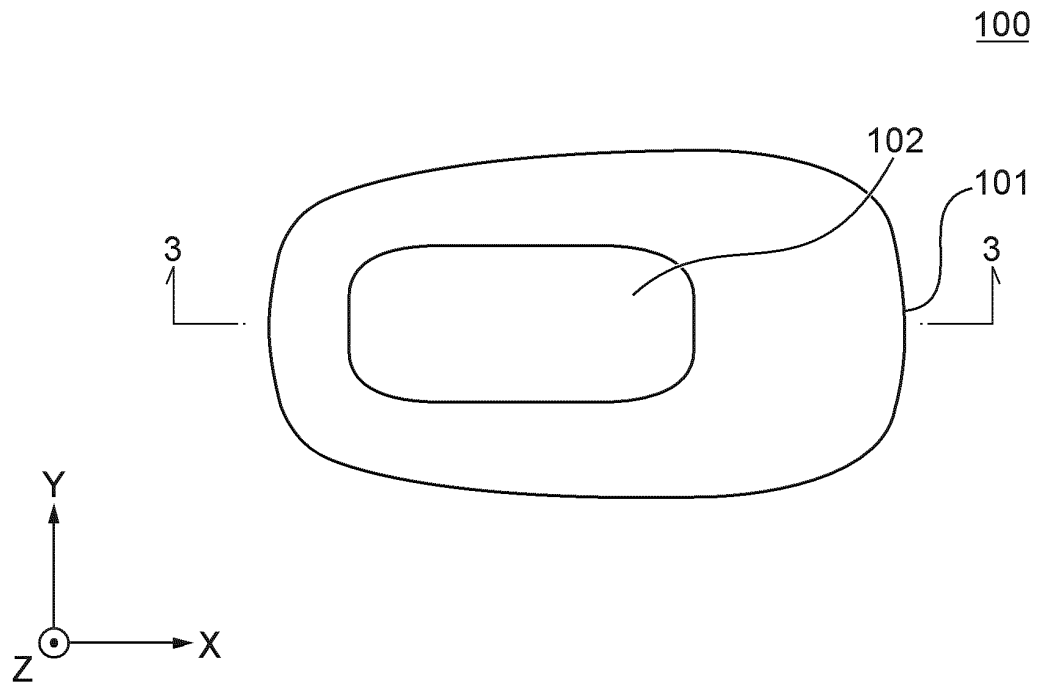

Fig. 1C

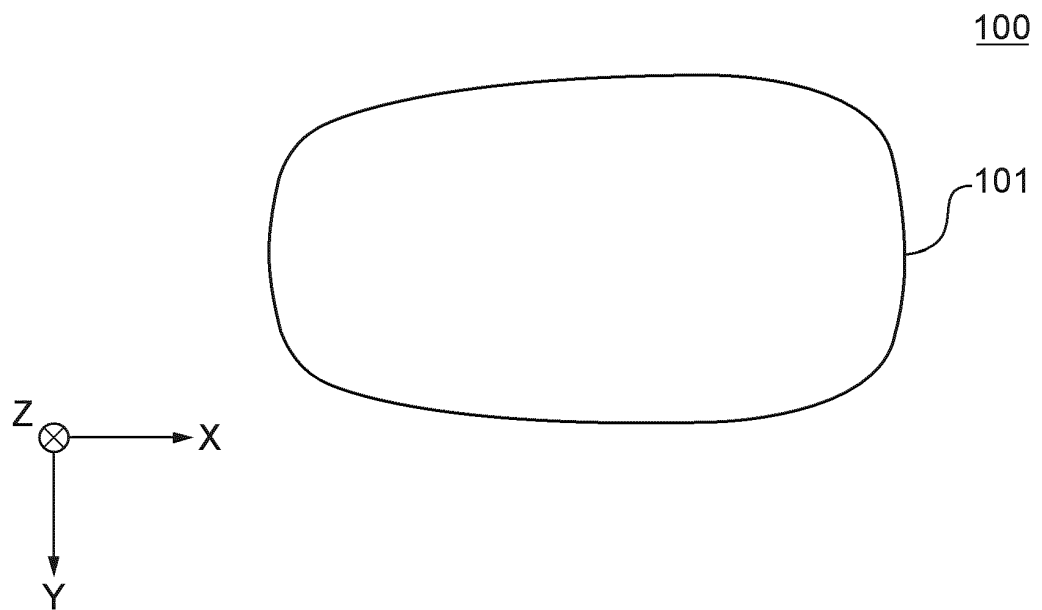

Fig. 2

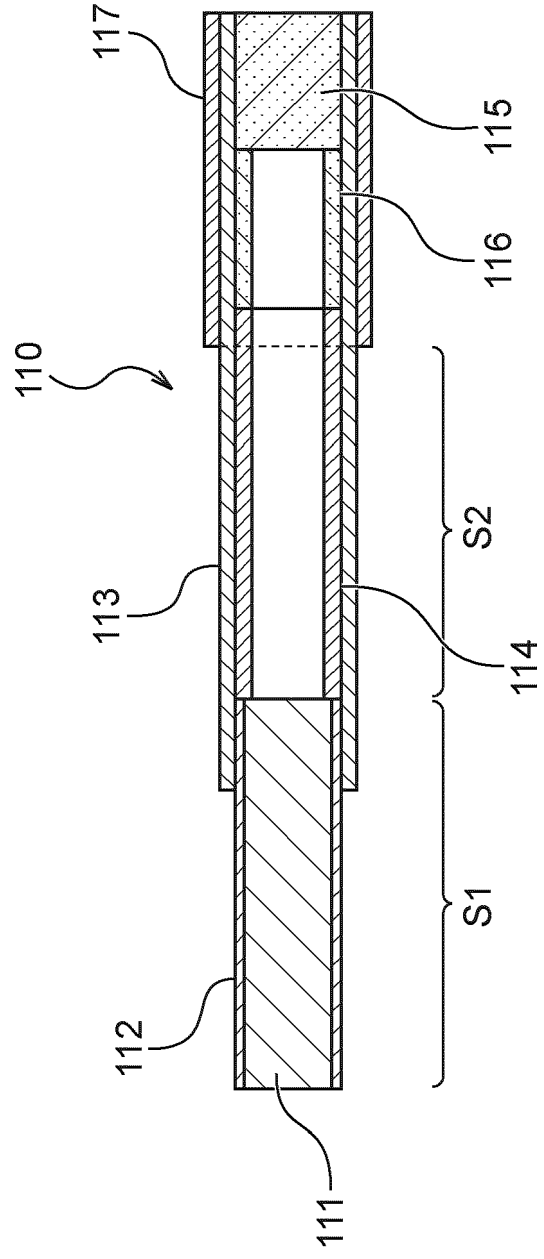

Fig. 3

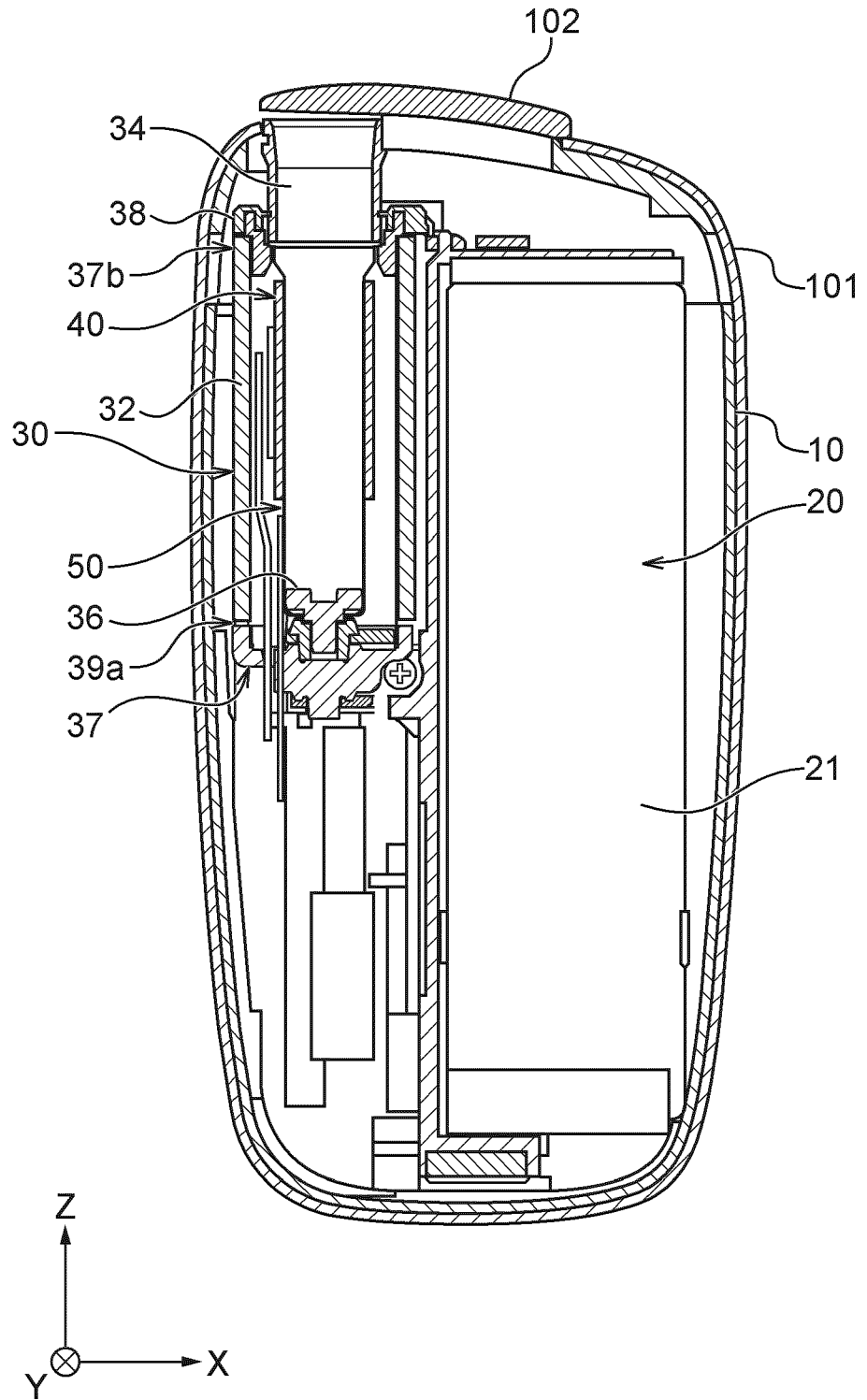

Fig. 4A

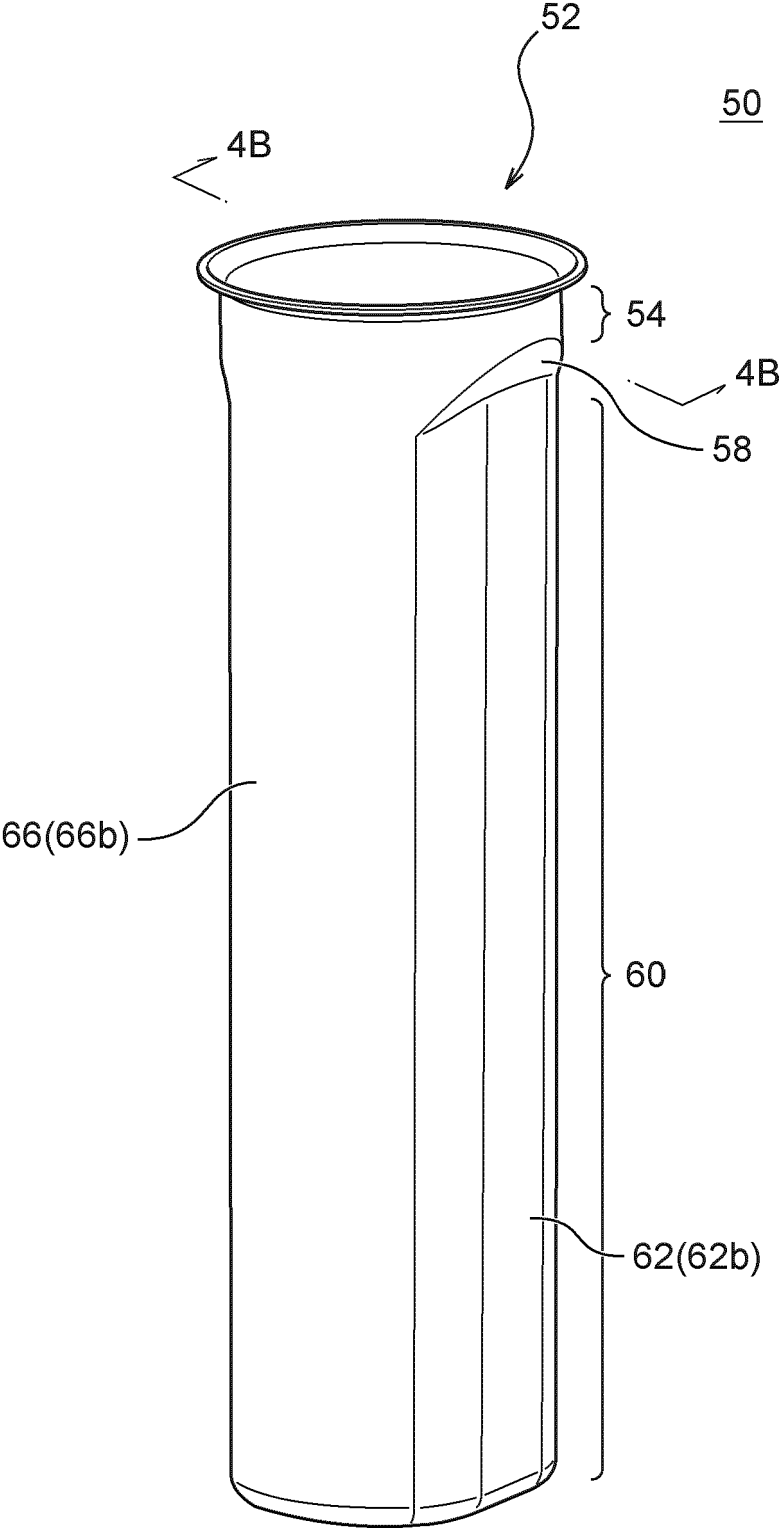

Fig. 4B

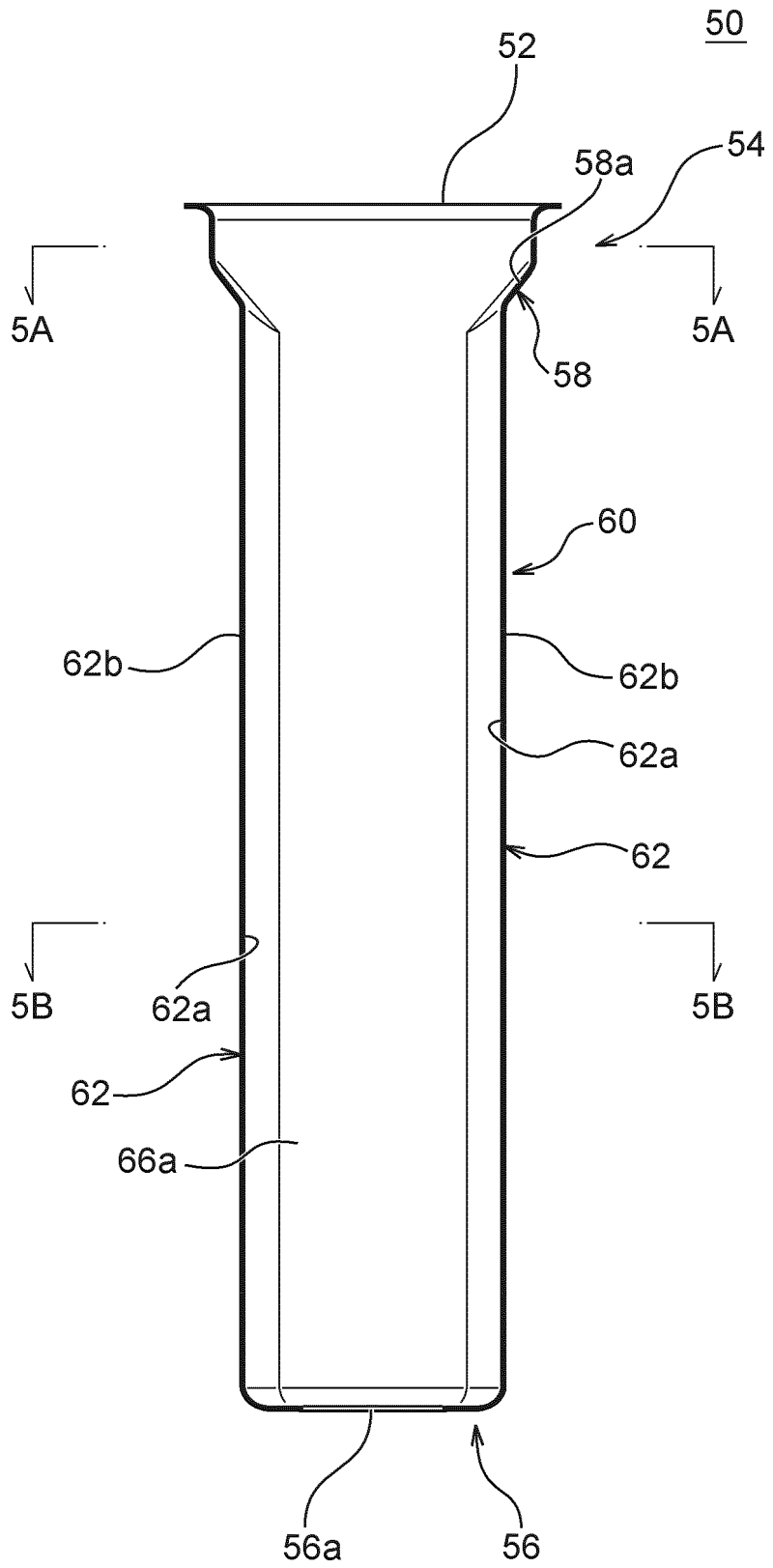

Fig. 5A

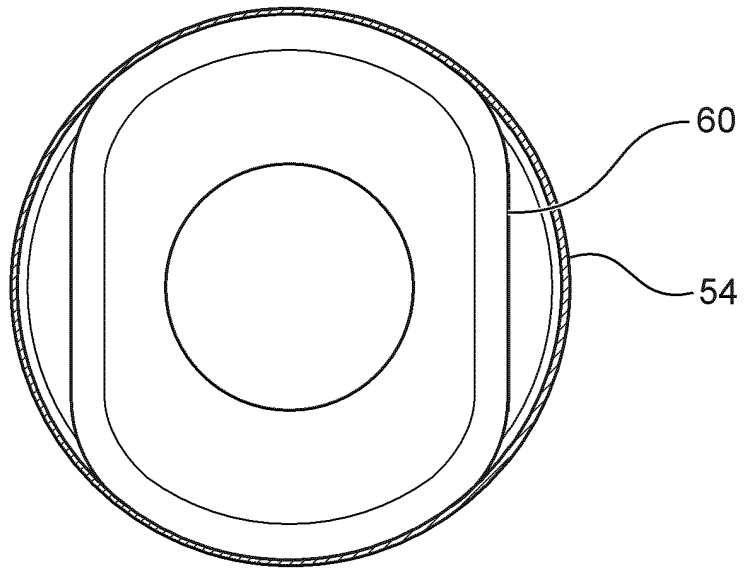

Fig. 5B

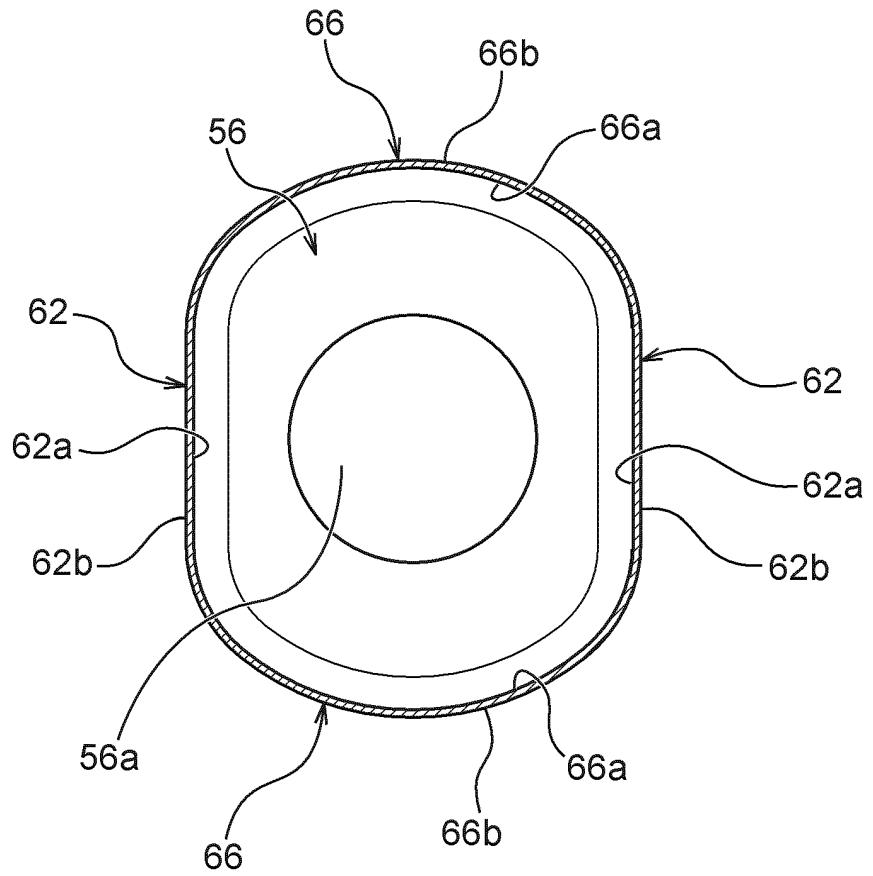

Fig. 6

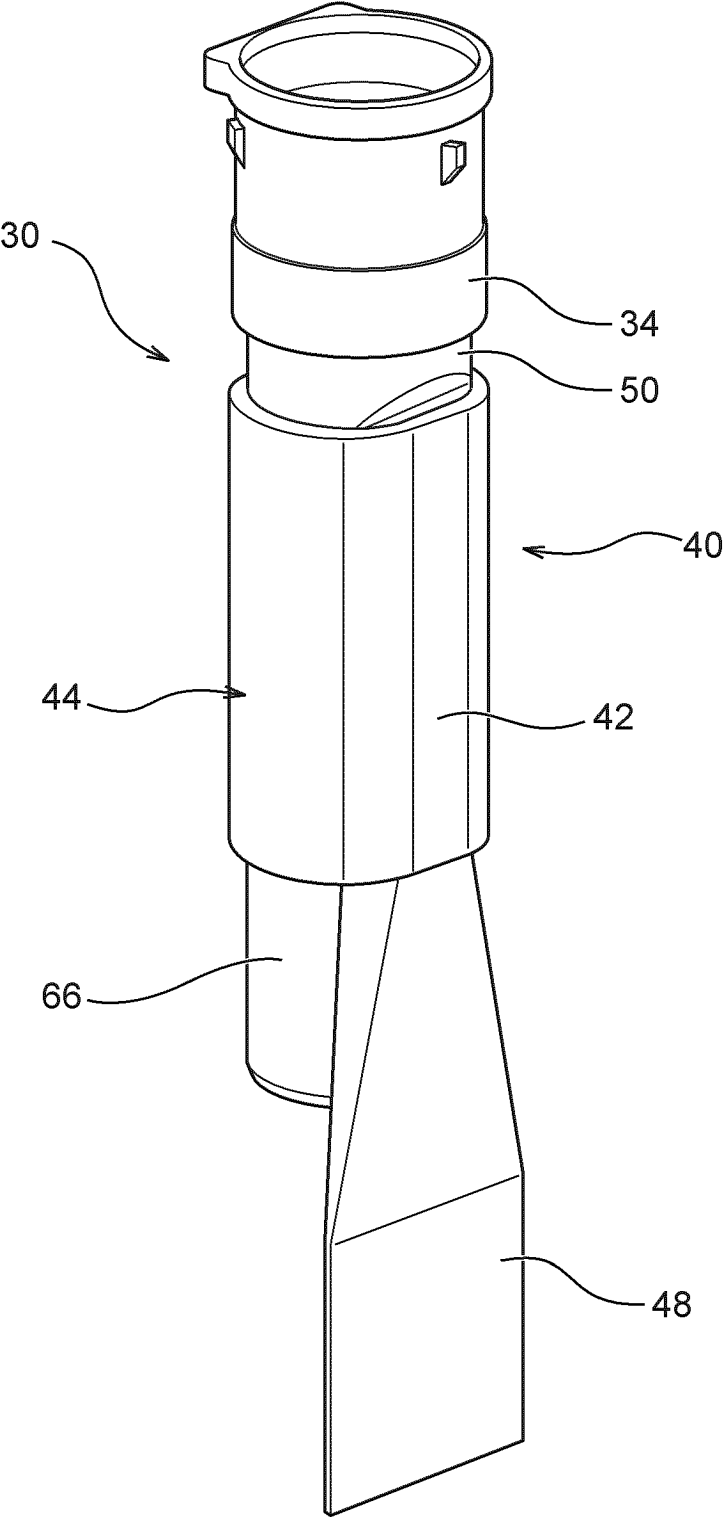

Fig. 7

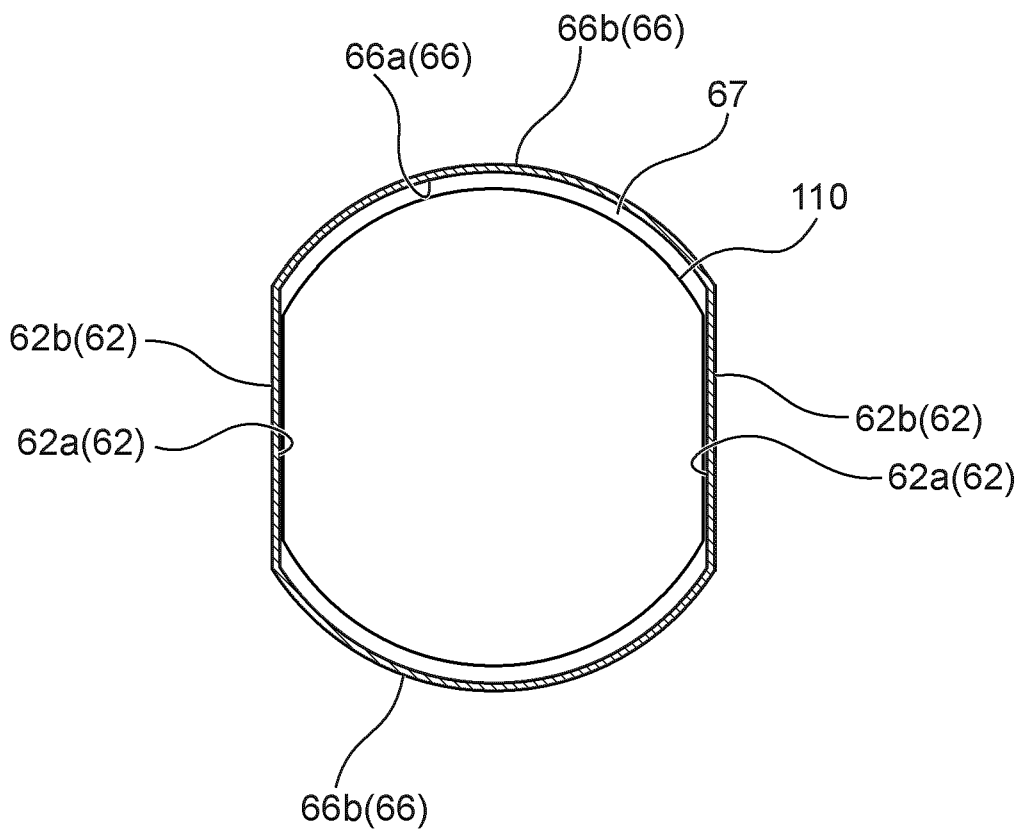

Fig. 8

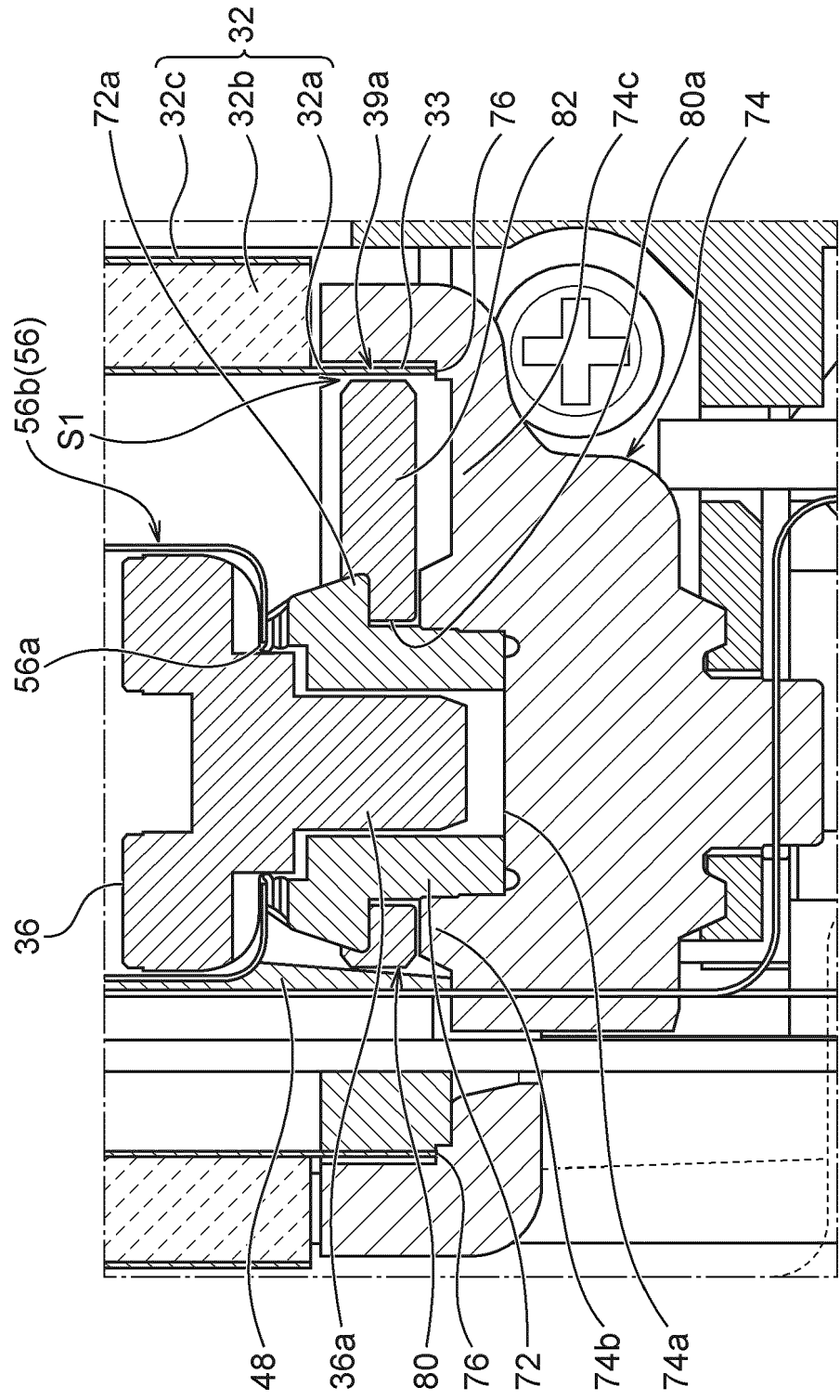

Fig. 9

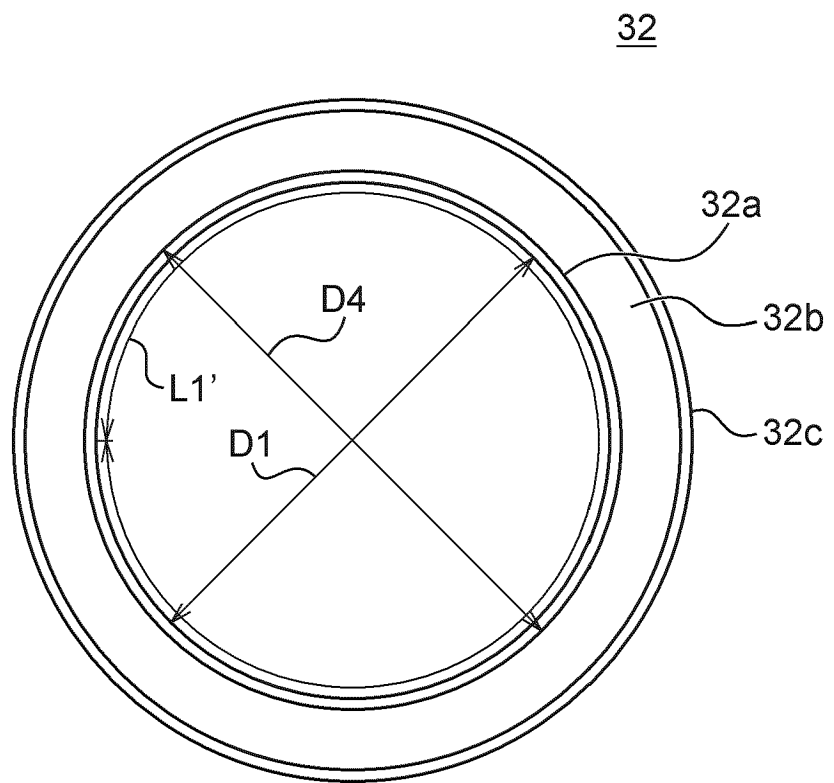

Fig. 10

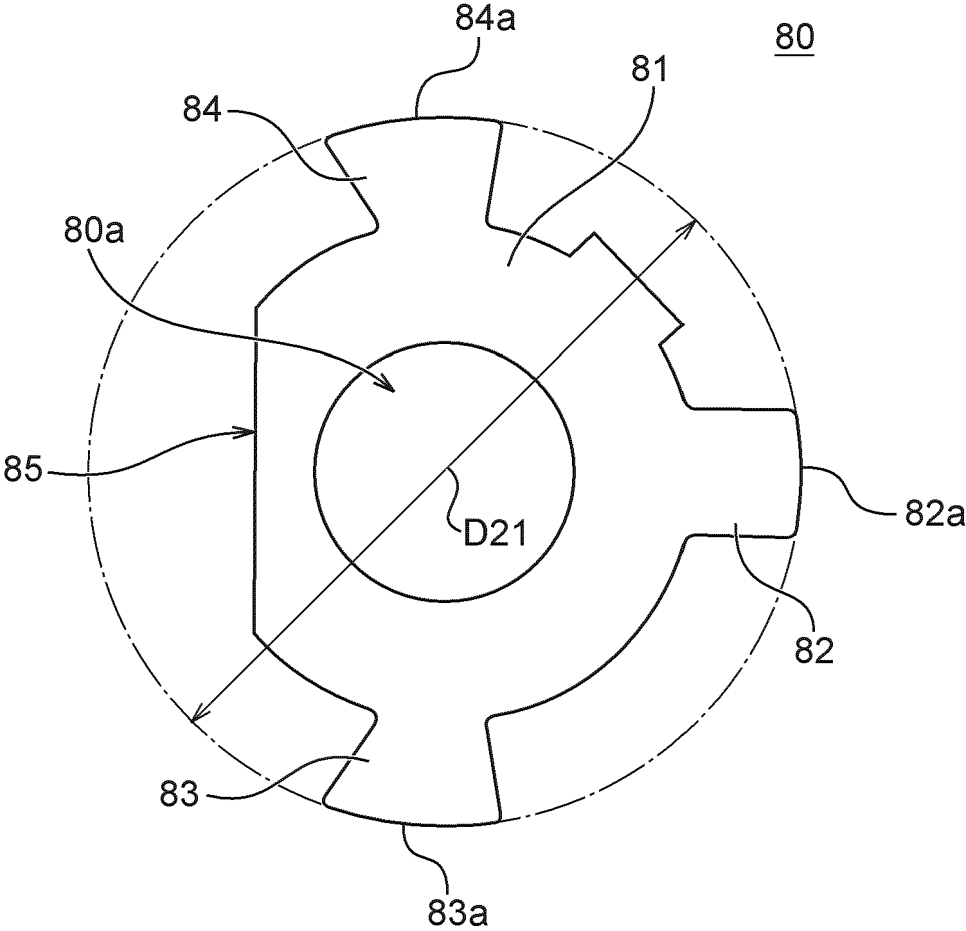

Fig. 11

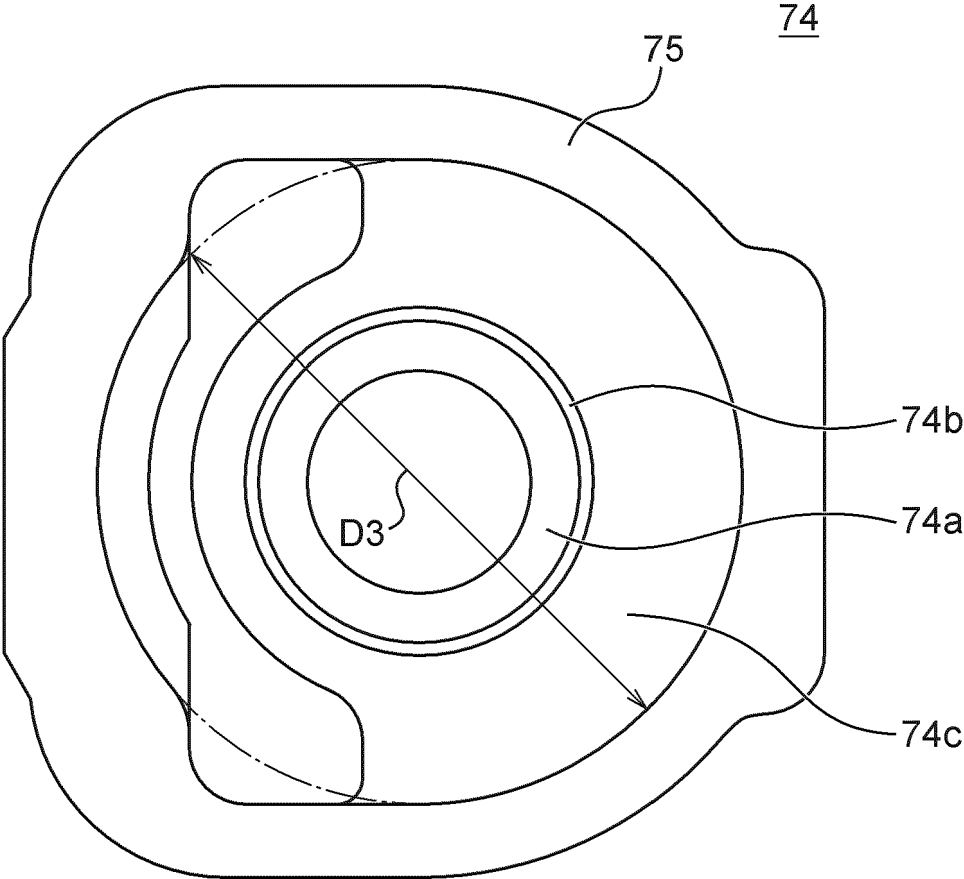

Fig. 12A

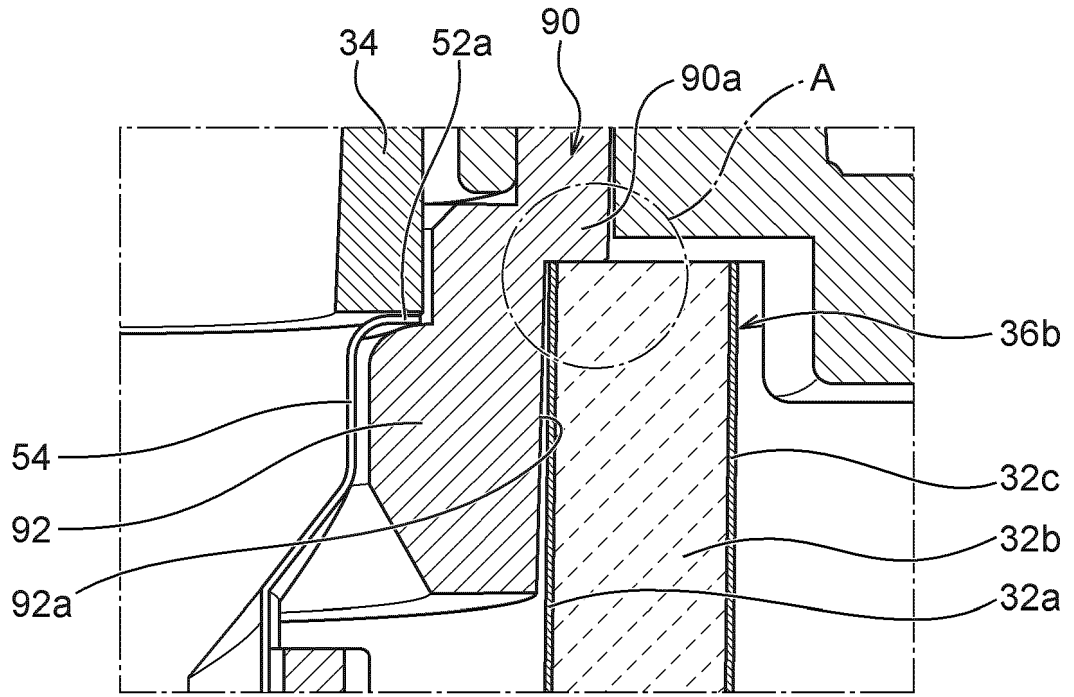

Fig. 12B

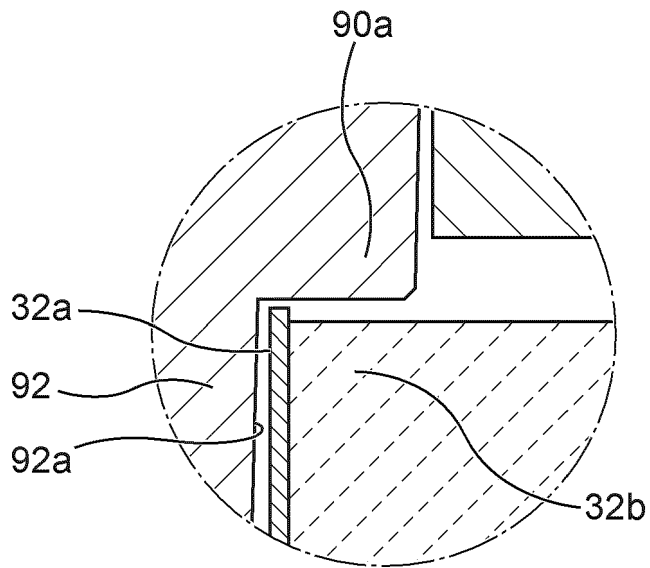
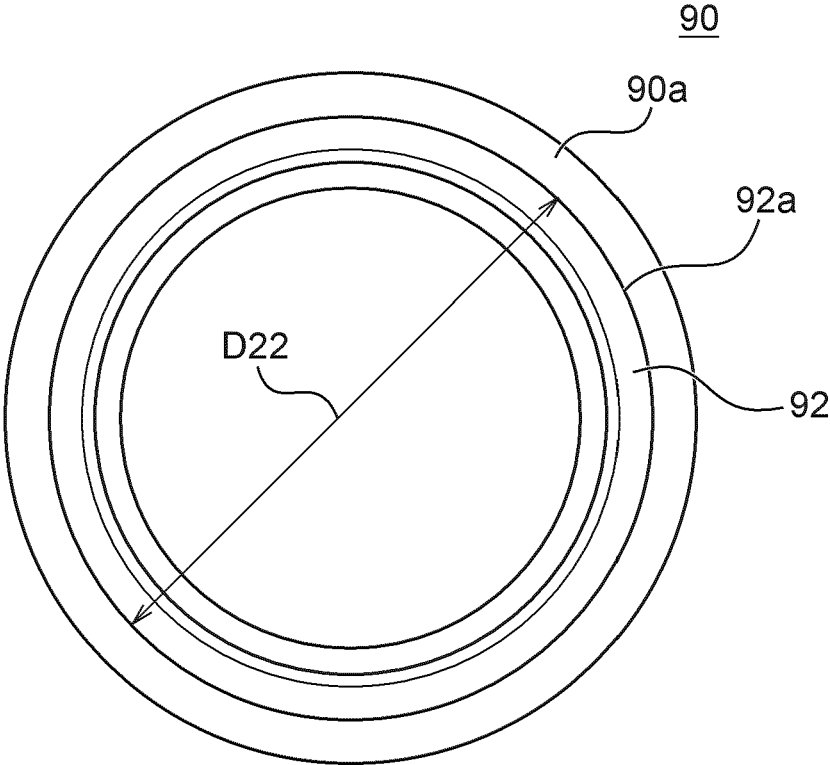

Fig. 13



REFERENCES CITED IN THE DESCRIPTION

This list of references cited by the applicant is for the reader's convenience only. It does not form part of the European patent document. Even though great care has been taken in compiling the references, errors or omissions cannot be excluded and the EPO disclaims all liability in this regard.

Patent documents cited in the description

- WO 2020035454 A1 [0002]
- WO 2020074604 A1 [0003]