

(19) World Intellectual Property Organization
International Bureau



(43) International Publication Date
16 October 2003 (16.10.2003)

PCT

(10) International Publication Number
WO 03/084437 A2

- (51) International Patent Classification⁷: **A61F 2/01**, 2/06
- (21) International Application Number: PCT/US03/07780
- (22) International Filing Date: 13 March 2003 (13.03.2003)
- (25) Filing Language: English
- (26) Publication Language: English
- (30) Priority Data:
10/113,724 1 April 2002 (01.04.2002) US
- (71) Applicant: **GORE ENTERPRISE HOLDINGS, INC.**
[US/US]; 551 Paper Mill Road, P.O. Box 9206, Newark,
DE 19714-9206 (US).
- (72) Inventors: **CULLY, Edward, H.**; 940 North Sinagua
Heights Drive, Flagstaff, AZ 86004 (US). **VONESH,
Michael, J.**; 3885 Kokopelli Lane, Flagstaff, AZ 86004
(US).
- (74) Agents: **CAMPBELL, John, S.** et al.; W.L. Gore & Associates, Inc., 551 Paper Mill Road, P.O. Box 9206, Newark, DE 19714-9206 (US).
- (81) Designated States (*national*): AE, AG, AL, AM, AT, AU, AZ, BA, BB, BG, BR, BY, BZ, CA, CH, CN, CO, CR, CU, CZ, DE, DK, DM, DZ, EC, EE, ES, FI, GB, GD, GE, GH, GM, HR, HU, ID, IL, IN, IS, JP, KE, KG, KP, KR, KZ, LC, LK, LR, LS, LT, LU, LV, MA, MD, MG, MK, MN, MW, MX, MZ, NO, NZ, OM, PH, PL, PT, RO, RU, SC, SD, SE, SG, SK, SL, TJ, TM, TN, TR, TT, TZ, UA, UG, UZ, VC, VN, YU, ZA, ZM, ZW.
- (84) Designated States (*regional*): European patent (AT, BE, BG, CH, CY, CZ, DE, DK, EE, ES, FI, FR, GB, GR, HU, IE, IT, LU, MC, NL, PT, RO, SE, SI, SK, TR).
- Published:**
— *with declaration under Article 17(2)(a); without abstract; title not checked by the International Searching Authority*
- For two-letter codes and other abbreviations, refer to the "Guidance Notes on Codes and Abbreviations" appearing at the beginning of each regular issue of the PCT Gazette.*



WO 03/084437 A2

(54) Title: ENDOLUMINAL DEVICES, EMBOLIC FILTERS, METHODS OF MANUFACTURE AND USE

(57) Abstract:

**ENDOLUMINAL DEVICES, EMBOLIC FILTERS, METHODS OF
MANUFACTURE AND USE**

FIELD OF THE INVENTION:

The present invention relates to seamless endoluminal devices including frame patterns for filters, their manufacture and use in the filtration and/or removal of embolic matter from fluids flowing in tubular body lumens including, but not limited to: blood flow in arteries and veins; airflow within the respiratory tract; and the flow of urine in the urinary tract. The seamless filter of the present invention may be self-expanding, is deployable via a guidewire-based system and has a low profile.

BACKGROUND OF THE INVENTION:

Embolic protection is a concept of growing clinical importance directed at reducing the risk of embolic complications associated with interventional (i.e., transcatheter) and surgical procedures. In therapeutic vascular procedures, liberation of embolic debris (e.g., thrombus, clot, atheromatous plaque, etc.) can obstruct perfusion of the downstream vasculature, resulting in cellular ischemia and/or death. The therapeutic vascular procedures most commonly associated with adverse embolic complications include: carotid angioplasty with or without adjunctive stent placement and revascularization of degenerated saphenous vein grafts. Additionally, percutaneous transluminal coronary angioplasty (PTCA) with or without adjunctive stent placement, surgical coronary artery by-pass grafting, percutaneous renal artery revascularization, and endovascular aortic aneurysm repair have also been associated with complications attributable to atheromatous embolization. Intra-operative capture and removal of embolic debris, consequently, may improve patient outcomes by reducing the incidence of embolic complications.

The treatment of stenoses of the carotid bifurcation provides a good example of the emerging role of adjuvant embolic protection. Cerebrovascular stroke is a principle source of disability among adults, and is typically associated with stenoses of the carotid bifurcation. The current incidence of cerebrovascular stroke in Europe and the United States is about 200 per 100,000 population per annum (Bamford, *Oxfordshire community stroke project. Incidence of stroke in Oxfordshire. First year's experience of a community stroke register. BMJ 287: 713-717, 1983*; Robins, *The national survey of stroke: the National Institute of Neurological and Communicative Disorders and Stroke. Office of Biometry and Field Studies Report. Chapter 4. Incidence. Stroke 12 (Suppl. 1): 1-57, 1981*). Approximately half of the patients suffering ischemic stroke have carotid artery stenoses (Hankey, *Investigation and imaging strategies in acute stroke and TIAs. Hospital Update 107 - 124,*

1992). Controlled studies have shown that the surgical procedure carotid endarterectomy (CEA) can reduce the incidence of stroke in patients compared to medical therapy with minimal perioperative complications (<6% for symptomatic patients with stenoses >70% [NASCET, *Beneficial effect of carotid endarterectomy in symptomatic patients with high grade stenoses. NEJM 325: 445 - 453, 1991*] and <3% for asymptomatic patients with 60% stenoses [ACAS, *Endarterectomy for asymptomatic carotid artery stenosis. JAMA 273: 1321-1461, 1995*]). These results provide convincing evidence of the benefit of treating carotid stenoses. Surgery, however, does have several limitations, including: increased mortality in patients with significant coronary disease (18%), restriction to the cervical portion of the extra-cranial vasculature, a predilection for cranial palsies (7.6%-27%), and restenosis (5%-19%; Yadav, *Elective stenting of the extracranial carotid arteries. Circulation 95: 376-381, 1997*).

Carotid angioplasty and stenting have been advocated as potential alternatives to CEA. Percutaneous techniques have the potential to be less traumatic, less expensive, viable in the non-cervical extracranial vasculature, and amenable to patients whom might otherwise be inoperable (Yadav, *Elective stenting of the extracranial carotid arteries. Circulation 95: 376-381, 1997*). Despite the potential benefits of this approach, emboli liberated during trans-catheter carotid intervention can place the patient at risk of stroke. Emboli can be generated during initial accessing of the lesion, balloon pre-dilatation of the stenosis, and/or during stent deployment. Additionally, prolapse of atheromatous material through the interstices of the stent can embolize after the completion of the procedure.

The fear of dislodging an embolus from an atherosclerotic plaque has tempered the application of angioplasty and endovascular stenting to the supraaortic arteries and, particularly, to the carotid bifurcation (Theron, *New triple coaxial catheter system for carotid angioplasty with cerebral protection. AJNR 11: 869-874, 1990*). This concern is warranted due to the significant morbidity and/or mortality that such an event might produce. While the incidence of stroke may be at an acceptable level for the highly skilled practitioner, it is likely to increase as the procedure is performed by less experienced clinicians.

Emboic protection devices typically act as an intervening barrier between the source of the clot or plaque and the downstream vasculature. In order to address the issue of distal embolization, numerous apparatus have been developed and numerous methods of embolic protection have been used adjunctively with percutaneous interventional procedures. These techniques, although varied, have a number of desirable features including: intraluminal delivery, flexibility, trackability, small delivery profile to allow crossing of stenotic lesions, dimensional compatibility with conventional interventional implements, ability to minimize flow perturbations, thromboresistance, conformability of the barrier to the entire luminal

cross-section (even if irregular), and a means of safely removing the embolic filter and trapped particulates.

For example, occlusion balloon techniques have been taught by the prior art and involve devices in which blood flow to the vasculature distal to the lesion is blocked by the inflation of an occlusive balloon positioned downstream to the site of intervention. Following therapy, the intraluminal compartment between the lesion site and the occlusion balloon is aspirated to evacuate any thrombus or atheromatous debris that may have been liberated during the interventional procedure. These techniques are described in Theron, *New triple coaxial catheter system for carotid angioplasty with cerebral protection*. *AJNR* 11: 869-874, 1990, and Theron, *Carotid artery stenosis: Treatment with protected balloon angioplasty and stent placement*. *Radiology* 201: 627-636, 1996, and are commercially embodied in the PercuSurge Guardwire Plus™ Temporary Occlusion and Aspiration System (Medtronic AVE). The principle drawback of occlusion balloon techniques stem from the fact that during actuation distal blood flow is completely inhibited, which can result in ischemic pain, distal stasis/thrombosis, and difficulties with fluoroscopic visualization due to contrast wash-out through the treated vascular segment.

Another prior system combines a therapeutic catheter (e.g., angioplasty balloon) and integral distal embolic filter. By incorporating a porous filter or embolus barrier at the distal end of a catheter, such as an angioplasty balloon catheter, particulates dislodged during an interventional procedure can be trapped and removed by the same therapeutic device responsible for the embolization. One known device includes a collapsible filter device positioned distal to a dilating balloon on the end of the balloon catheter. The filter comprises a plurality of resilient ribs secured to the circumference of the catheter that extend axially toward the dilating balloon. Filter material is secured to and between the ribs. The filter deploys as a filter balloon is inflated to form a cup-shaped trap. The filter, however, does not necessarily seal around the interior vessel wall. Thus, particles can pass between the filter and the vessel wall. The device also presents a large profile during positioning and is difficult to construct.

The prior art has also provided systems that combine a guidewire and an embolic filter. The filters are incorporated directly into the distal end of a guidewire system for intravascular blood filtration. Given the current trends in both surgical and interventional practice, these devices are potentially the most versatile in their potential applications. These systems are typified by a filter frame that is attached to a guidewire that mechanically supports a porous filter element. The filter frame may include radially oriented struts, one or more circular hoops, or a pre-shaped basket configuration that deploys in the vessel. The filter element typically includes a polymeric mesh net, which is attached in whole or in part to

the filter frame and/or guidewire. In operation, blood flowing through the vessel is forced through the mesh filter element thereby capturing embolic material in the filter.

Early devices of this type include a removable intravascular filter mounted on a hollow guidewire for entrapping and retaining emboli. The filter is deployable by manipulation of an actuating wire that extends from the filter into and through the hollow tube and out the proximal end. During positioning within a vessel, the filter material is not fully constrained so that, as the device is positioned through and past a clot, the filter material can potentially snag clot material creating freely floating emboli, prior to deployment.

In another prior art system an emboli capture device is mounted on the distal end of a guidewire. The filter material is coupled to a distal portion of the guidewire and is expanded across the lumen of a vessel by a fluid activated expandable member in communication with a lumen running the length of the guidewire. During positioning, as the device is passed through and beyond the clot, filter material may interact with the clot to produce emboli. This device may also be difficult to manufacture.

Another prior art device is adapted for deployment in a body vessel for collecting floating debris and emboli in a filter that includes a collapsible proximally tapered frame for operably supporting the filter between a collapsed insertion profile and an expanded deployment profile. The tapered collapsible frame includes a mouth that is sized to extend to the walls of the body vessel in the expanded deployed profile to seal the filter relative to the body vessel for collecting debris floating in the body vessel.

A further example of an embolic filter system involves a filter material fixed to cables or spines of a central guidewire. A movable core or fibers inside the guidewire can be utilized to transition the cables or spines from approximately parallel to the guidewire to approximately perpendicular to the guidewire. The filter, however, may not seal around the interior vessel wall. Thus, particles can pass between the filter and the entire vessel wall. This umbrella-type device is shallow when deployed so that, as it is being closed for removal, particles have the potential to escape.

Other disadvantages associated with the predicate devices are that the steerability of the guidewire may be altered as compared to the conventional guidewires due to the presence and size of the filter. The guidewire, for example, may bend, kink, and/or loop around in the vessel, making insertion of the filter through a complex vascular lesion difficult. Also, delivery of such devices in a low-profile pre-deployment configuration can be difficult. Further, some devices include complex and cumbersome actuation mechanisms. Also, retrieving such capture devices after they have captured emboli may be difficult. Further, when deployed in curved segments, the interaction of the guidewire and/or tether elements can deform the filter frame in such a way as to limit apposition to the host vessel wall, thereby allowing potential channels for passage of embolic debris. Also, the filter media of

the prior art maintains a pore diameter of approximately 80 to 120 microns. It is desirable to minimize the pore size without adversely perturbing blood flow or being prone to clogging.

Current filter designs suffer from numerous disadvantages due to their construction. A typical wire filter is formed by manipulating multiple wires together through welding or some other form of attachment. After the wire frame is constructed, it is formed into the desired shape and a filter element is affixed onto the wire cage. A typical wire frame constructed in this manner is subject to a limited range of manipulation after the wires are adhered, since the welds or attachment areas are at an increased risk of failure due to the physical constraints of the welds themselves. A wire pair is more inclined to fracture at the weakest point, typically, a wire frame, composed of numerous wire pairs, will separate at the weld before separating in the length of the wire. Additionally, the welding of metal involves the application of increased heat to join a wire pair and a risk exists of the mesh, formed by the pairs, dripping or otherwise malforming due to the proclivity of metal to run before cooling.

A further disadvantage to a typical wire filter is that the filter element is difficult to apply to the frame since the filter is normally applied as a sock, tube, or other such shape. The typical wire frame is formed by welding and bending into the desired shape. The filter is then affixed onto the shaped wire frame by pulling the formed filter over the shaped wire frame. An additional problem evident in this construction is that the filter element could be abraded by a protrusion formed by a weld in a wire pair. Such an abrasion could form a weakness or a tear in the filter and undermine its desired functionality.

Simple and safe blood filtering and guidewire systems that can be temporarily placed in the vasculature to prevent distal embolization during endovascular procedures, and that can be used to introduce and/or exchange various instruments to a region of interest without compromising the position of the filter or guidewire, are required. Existing guidewire-based embolic filtering devices are inadequate for these and other purposes. The present apparatus, in contrast, provides a novel means of providing these and other functions, and has the further benefit of being easier to manufacture than the devices of the prior art.

SUMMARY OF THE INVENTION:

The present invention relates to seamless implantable devices, filters, methods of manufacture, systems for deployment and methods of use.

One aspect of the present invention is to provide a low profile filter formed from a single piece of material.

Another aspect of the present invention is to provide a self-expanding filter that is seamless.

A further aspect of the present invention is to provide an integral self-expanding filter frame that is seamless.

A still further object of the present invention is to provide a seamless, low-profile filter that minimally perturbs flow.

A further aspect of the present invention to provide a low profile, seamless filter that is readily connected to the guidewire of a endoluminal deployment system.

A further aspect of the invention is to provide a filter apparatus, which maintains vessel wall apposition and a maximally open mouth when deployed in tortuous anatomy.

A further aspect of the invention is to provide a filter frame, which can be rendered sufficiently radiopaque.

A further aspect of the present invention is to provide filters which have increased capture efficiency and are capable of providing drug delivery.

A further aspect according to the present invention includes providing a seamless frame having a proximal end, a longitudinal axis, a seamless support member circumscribing the axis and distally spaced from the proximal end, and at least one attachment strut, and optionally at least one filter strut seamlessly extending from the support member.

Another aspect of the present invention is to provide a seamless frame having a proximal end, a longitudinal axis, a seamless support member circumscribing the axis and distally spaced from the proximal end, and at least one attachment strut, optionally at least one filter strut seamlessly extending from the support member, and at least one or more filter media layers.

Another aspect of the present invention is to provide implantable devices that may be configured as detachable devices designed for permanent implantation and/or subsequent retrieval and are used for: temporary vascular occluders; exclusion of bleeding varices or aneurysmal vascular segments; a stent, or similar means of providing structural support to an endoluminal cavity; a thrombectomy/atherectomy instrument; an implantable prosthetic vascular conduit wherein the proximal filter frame functions as an anchoring stent, and the distal filter is configured into an open-ended, tubular configuration (similar to a windsock) allowing endoluminal lining of a vascular segment with a biocompatible liner.

An aspect of the present invention is to provide seamless implantable devices formed from a single piece of material.

Another aspect of the present invention is to provide seamless implantable devices that have regions of articulation and/or radiopaque markers.

A further aspect of the present invention to provide seamless implantable devices that include radiopaque markers.

A still further aspect of the present invention is to provide stents or similar means of providing structural support to an endoluminal cavity, and which may include regions of articulation and/or radiopaque markers.

A further aspect of the present invention to provide a seamless stent, or similar means of providing structural support to an endoluminal cavity.

A still further aspect of the present invention is to provide a delivery system for the inventive seamless devices, stents, occluders, filters and its use. These and other features and aspects of the invention will become more apparent in view of the following detailed description, non-limiting examples, appended claims and drawings.

BRIEF DESCRIPTION OF THE DRAWINGS:

Figures 1A, 1B and 1C illustrate the steps of constructing a first two-dimensional frame, whereas **Figures 1D and 1E** illustrate a resulting three-dimensional shape with a filter media attached thereto.

Figures 2A, 2B and 2C respectively illustrate an alternate configuration of a two-dimensional frame, a resulting three-dimensional shape after annealing and a depiction of the frame with a filter media attached.

Figures 3A, 3B and 3C respectively illustrate an alternate configuration of a two-dimensional frame, a resulting three-dimensional shape after annealing and a depiction of the frame with a filter media attached.

Figures 4A, 4B and 4C respectively illustrate an alternate configuration of a two-dimensional frame, a resulting three-dimensional shape after annealing and a depiction of the frame with a filter media attached.

Figures 5A, 5B and 5C respectively illustrate an alternate configuration of a two-dimensional frame, a resulting three-dimensional shape after annealing and a depiction of the frame with a filter media attached.

Figures 6A, 6B and 6C respectively illustrate an alternate configuration of a two-dimensional frame, a resulting three-dimensional shape after annealing and a depiction of the frame with a filter media attached.

Figures 7A, 7B and 7C respectively illustrate an alternate configuration of a two-dimensional frame, a resulting three-dimensional shape after annealing and a depiction of the frame with a filter media attached.

Figure 7D illustrates an annealed frame pattern having articulation segments in the attachment struts and **Figure 7E** illustrates a frame pattern having longitudinally spaced support members interconnected by articulation segments.

Figures 8A, 8B and 8C respectively illustrate an alternate configuration of a two-dimensional frame, a resulting three-dimensional shape after annealing and a depiction of the frame with a filter media attached.

Figures 9A, 9B and 9C respectively illustrate an alternate configuration of a two-dimensional frame, a resulting three-dimensional shape after annealing and a depiction of the frame with a filter media attached.

Figures 10A, 10B and 10C respectively illustrate an alternate configuration of a two-dimensional frame, a resulting three-dimensional shape after annealing and a depiction of the frame with an integral filter media.

Figures 11A, 11B and 11C respectively illustrate an alternate configuration of a two-dimensional frame, a resulting three-dimensional shape after annealing and a depiction of the frame with a filter media attached.

Figures 12A, 12B, 12C, 12D and 12E respectively illustrate alternate apex and strut configurations adapted to accept and house radio-opaque markers.

Figure 13 illustrates a three-dimensional frame with an attached filter media positioned between a guidewire and an atraumatic tip.

Figures 14A and 14B depict the filtering apparatus as deployed within a vessel having tortuous anatomy.

Figure 15 illustrates an alternate system for assembling an alternate embolic filter configuration.

Figure 16 illustrates a system for assembling a filter-in-filter device.

Figure 17 illustrates the filter-in-filter assembled using the system of **Figure 16**.

Figures 18A, 18B and 18C respectively illustrate a tooling device, a two-dimensional frame being formed into a three-dimensional configuration, and the tooling device supporting the three-dimensional frame for annealing.

Figures 19A, 19 B and 19C respectively illustrate the steps for converting a conical filter into "sombbrero" shaped filter configuration.

Figure 19D illustrates a three-dimensional frame supporting a "sombbrero" shaped filter media.

Figures 19 E and 19F depict an alternative filter sack configuration in which the sack resembles an asymmetric cone.

Figures 20A, 20B and 20C respectively illustrate a filter-in-filter configuration with a pharmacological agent loaded in the space between the filter media, an alternate filter configuration with the filter media pre-loaded with the pharmacological agent, and the elution of the pharmacological agent in a lumen/vessel of a host.

Figures 21A and 21B respectively illustrate deployment of an occluder device in a lumen/vessel of a host and the detachment of the occluder.

Figures 22A and 22B respectively illustrate the deployment of an obstruction remover and collection of removed lesion debris in a lumen/vessel of a host.

Figures 23A, 23B and 23C illustrate the use of an anchoring device for treatment of a lesion in tortuous vessels associated with renal anatomy.

Figures 24A, 24B, 24C, 24D and 24E respectively illustrate a two dimensional frame, a three-dimensional resulting shape, an endovascular device formed from the three-dimensional frame and an open-ended windssock, the occlusion of a sacular aneurysm in a host lumen/vessel with the endovascular device and optional use of a stent lining the device.

Figure 25A illustrates a delivery catheter having a guidewire lumen and guidewire supported filter.

Figures 25B, 25C, 25D and 25E respectively illustrate views of alternate distal catheter delivery tips.

Figures 25F, 25G and 25H respectively illustrate three-dimensional top views of catheter tube having a channel indented in its surface adjacent its distal end, a sleeve covering the indented channel and a guidewire located in the sleeve covered-indented channel.

Figures 26A, 26B, 26C, 26D and 26E respectively illustrate steps followed in treating a lesion in a host lumen/vessel.

Figures 27A, 27B and 27C respectively illustrate a view of the distal tip a delivery catheter with an alternate auxiliary lumen configuration, a three-dimensional top view of the auxiliary lumen configuration and an auxiliary lumen mounted guidewire.

Figure 28 illustrates a configuration of the present invention deployed as an implantable vena cava filter.

Figures 29A and 29B respectively illustrate an alternate two-dimensional planar configuration of the present invention, and a three-quarter isometric view of this configuration formed into a three-dimensional shape designed for use as an implantable stent.

Figure 30 is a flat pattern view of a filter frame and integral tether elements as would be cut from a tube.

Figure 31 is a flat pattern view of a filter frame and integral tether elements after being formed and annealed at a functional size.

Figures 32A, 32B, 32C, 32D and 32E respectively show variations in the tether geometry, designed to allow the tethers to articulate with respect to one another and to the filter frame itself.

DETAILED DESCRIPTION OF THE INVENTION:

As used herein the following terms are defined as followed:

The term "proximal" is defined as the location closest to the catheter hub and "distal" is the location most distant from the catheter hub. With respect to the inventive three-dimensional uni-body frame, the term "proximal" is the frame end attached to the guidewire or the frame side through which debris enters to be collected by an associated filter.

The term "uni-body" refers to a frame pattern formed from a single piece of material and therefore considered "seamless."

Terms such as unitary, integral, one-piece are synonymous with "uni-body" and also refer to a frame pattern that is formed from a single or common piece of material.

Filament, wire or ribbon are alternate terms used to describe the portions/sections of pattern material that remain after etching a planar precursor frame material and form the attachment struts, the support struts, the filter/filter support struts that extend in the longitudinal, circumferential, or any other direction necessary to define a frame pattern.

Figures 1A -1D schematically show the four method steps that are followed to manufacture a uni-body, self-expanding filter device in accordance with the present invention. **Figure 1A** shows a flat sheet material **110**, preferably a shape memory alloy material, e.g., a NiTi alloy, Nitinol, or any other suitable bioacceptable material, such as a metal, e.g., stainless steel, or bioacceptable polymer. The flat sheet material **110** is used to form the "uni-body" frame pattern **115** of **Figure 1C**, or other frame patterns described hereinafter.

A desired pattern is formed on sheet material **110**, as in the case of **Figure 1B**, which shows a radially symmetric filter frame pattern having six "pie" shaped wedges **120**. The wedges **120** are removed by etching in a chemical photo-etching process, or any other suitable technique, to form a frame defined by filament sized material. The frame pattern can also be obtained by using a laser or any other cutting procedure or process capable of precisely etching, stamping, or otherwise cutting the flat sheet **110** into the preferred shape.

Radial sides **125**, **130** and arcuate side **135** circumscribe the wedges **120**. Slits **145** are formed and center section **150** is removed by any suitable cutting technique. After the slits **145** are formed, and wedges **120** and center section **150** removed, flashing **140** is removed (such as by trimming with fine scissors or diagonal cutters), leaving the desired skeletal two-dimensional filter frame/pattern **115**, shown in **Figure 1C**.

Skeletal frame **115** includes attachment struts **155** with proximal ends **165** that are to be fixed or attached to proximal connecting member **170** of **Figure 1D**, adapted to cooperate with a guidewire (not shown). Attachment struts **155** extend seamlessly from support struts **156** because they are formed from the same precursor material. Support struts **156** are seamlessly connected to or seamlessly interconnected with one another.

Seamlessly interconnected support struts **156** define a boundary, perimeter or cell having the configuration of a six-pointed “star.” When frame **115** is converted into a three-dimensional configuration, the seamlessly associated/interconnected struts **156** typically form a “closed” support member **156A** that circumscribes the longitudinal axis of the three-dimensional frame, thereby providing a radial or transverse dimension to the three-dimensional frame. The boundary, perimeter, cell or support member **156A** can be any geometric configuration so long as it provides a radial dimension (transverse to the longitudinal axis) for the frame. The support member circumscribes the longitudinal axis of the frame and may also be described as being ring-shaped. In addition to providing the frame with a radial dimension, as shown in **Figure 1D**, the support member **156A** is typically the location for attaching the proximal open end **161** of the filter **160**. Thus the support member also functions to maintain the proximal end of filter media **160** in the open operative configuration. Filter media **160** may be formed from any suitable material, and also includes a closed distal end **162**.

The planar, two-dimensional frame pattern of **Figure 1C** is then annealed, normally by thermal annealing, into a three-dimensional configuration. The three-dimensional annealed frame configuration **175**, may be further processed, as described hereinafter, to include a filter media resulting in filter **100** which includes the frame **175** and filter media **160**, as in **Figures 1D** and **1E**. For ease of consistency and brevity throughout the remainder of the application and without relinquishing equivalents thereof, Nitinol is used as the filter frame material in each and every embodiment shown and described hereinafter. However, as discussed above, other suitable materials, such as, titanium nickel alloys, shape memory materials, biocompatible metals, e.g., stainless steel, or plastic may be used for the uni-body filter frame.

Figures 2A – 2C through **11A – 11C** depict alternate filter frame patterns that can be formed following the procedures described with reference to **Figures 1A – 1E**. As a result, the various struts are seamlessly interconnected since they are formed from the same precursor material.

Figure 2A illustrates a plan view of an alternate frame pattern **215** having hoop shaped struts **256** connected to attachment struts **255**. **Figure 2B** illustrates the three dimensional filter frame **275** after annealing with proximal ends of the attachment struts **255** fixed to the proximal connecting member **270** and struts **256** seamlessly connected to one another and forming a closed support member **256A**. As with **Figure 1C**, struts **255** seamlessly extend from support member **256A**. **Figure 2C** illustrates a filter **200** attached to a guidewire **280**. The filter **200** includes the three-dimensional frame **275** with a filter media **260** having a “butterfly” configuration. The configuration of filter media **260** can also be described as substantially parabolic.

Figure 3A illustrates an alternate two-dimensional (plan view) frame pattern **315** having attachment struts **355**, attachment strut proximal ends **365**, filter struts **385** which may also support optional filter media **360** of **Figure 3D**. Filter pattern **315** also includes support struts **356**. Support struts **356** and filter struts **385**, which are seamlessly associated with one another, cooperate to define cell **357**, which is configured in the shape of a diamond. Struts **355**, **356** and **385** are seamlessly associated with one another since they are formed from the same precursor material. Struts **356** define a boundary around six cells **357** and form a closed support member **356A** for maintaining the three-dimensional filter of **Figure 3C** in an open, operative configuration. **Figure 3B** illustrates three-dimensional frame **375** that is obtained after the two dimensional filter frame pattern is annealed, with the proximal ends **365** of the attachment struts **355** fixed to proximal connecting member **370**. In the embodiment of **Figure 3B**, the filter struts **385** allow the device to be used as a filter, without the filter media shown in **Figure 3C**. While the filter pattern of **Figure 3B** shows six filter struts **385**, any number of filter struts or support struts can be used, including, but not limited to **4**, **5**, **7**, **8**, **9**, **10**, **11**, **12**, etc. In addition, although **Figure 3A** depicts the filter frame **315** with diamond shaped cells/openings **357**, cells **357** can be of any geometrical shape or size, so long as the openings are of sufficient size to permit blood flow and/or filtering. **Figure 3C** illustrates the annealed filter frame pattern of **Figure 3B** with filter media **360** attached to a guidewire **380**.

Figure 4A illustrates a two-dimensional alternate seamless frame pattern **415** having attachment struts **455**, support struts **456**, and filter/filter media support struts **485**. The pattern is seamless because it is formed from the same precursor material. **Figures 4B** and **4C** illustrate three-dimensional views of filter frame pattern **475** after annealing, with the proximal ends of the attachment struts **455** fixed to the proximal connecting member **470**, support struts **456** forming support member **456A**, and filter media support struts **485** extending in a distal direction. **Figure 4C** illustrates the annealed filter frame pattern **475** of **Figure 4B** with filter media **460** attached to a guidewire **480**.

Figure 5A illustrates the two-dimensional alternate seamless filter pattern **515** having attachment struts **555**, support struts **556**, filter media support members **590**, and filter support struts **585**. The pattern is seamless because it is formed from the same precursor material. **Figures 5B** and **5C** illustrate three-dimensional views of the filter frame pattern **515** of **Figure 5A** after annealing, frame **575**, with proximal ends of the attachment struts **555** fixed to the connecting member **570**, support struts **556** of **Figure 5A** form closed support member **556A**, and filter media support struts **585** extend distally away from the proximal connector **570**. **Figure 5C** illustrates the annealed filter frame pattern **575** of **Figure 5B** with filter media **560** attached to a guidewire **580**.

Figure 6A illustrates the two-dimensional alternate seamless filter pattern **615** having attachment struts **655**, support struts **656** and filter support struts **685**. The pattern is seamless because it is formed from the same precursor material. **Figures 6B** and **6C** illustrate three-dimensional views of filter frame pattern **615** of **Figure 6A** after annealing, with the proximal ends of the attachment struts **655** fixed to the connecting member **670**, support struts **656** of **Figure 6A** forming support member **656A** and filter media support struts **685**. **Figure 6C** illustrates the annealed filter frame pattern **675** of **Figure 6B** with filter media **660** attached to a guidewire **680**.

Figure 7A illustrates a two-dimensional view of a seamless alternate filter pattern **715** having attachment struts **755** and support member struts **756**. The pattern is seamless because it is formed from the same precursor material, for supporting the open end of filter media **760** of **Figure 7C**. **Figures 7B** and **7C** illustrate side views of the three-dimensional filter frame **775**, after annealing, with the proximal ends of the attachment struts **755** fixed to the connecting member **770** and support struts **756** of **Figure 7A** forming support member **756A**. **Figure 7C** illustrates the annealed filter frame pattern of **Figure 7B** with filter media **760** attached to a guidewire **780**. **Figure 7D** illustrates the annealed frame pattern having articulation segments **790** in the attachment struts **755**. **Figure 7E** illustrates an alternate design, wherein there are two longitudinally spaced support members **756A** seamlessly interconnected to one another by articulation segments **790**, described in greater detail hereinafter.

Figure 8A illustrates a two-dimensional view of an alternate spirally configured filter pattern **815**. **Figures 8B** and **8C** illustrate three-dimensional views of the filter frame pattern **815** of **Figure 8A** after annealing, frame **875**, with a proximal end of the frame **875** fixed to the connecting member **870**. **Figure 8C** illustrates the annealed filter frame pattern of **Figure 8B** with filter media **860** attached to a guidewire **880**. In the filter frame illustrated in **Figure 8B**, one of the turns of the spirally shaped frame, which is not "closed," forms the support member that provides radial dimension to the frame.

Figure 9A illustrates a two-dimensional view of an alternate seamless filter pattern **915** having attachment struts **955** and filter media support struts **985**. The pattern is seamless because it is formed from the same precursor material. **Figures 9B** and **9C** illustrate three-dimensional views of the filter frame pattern after annealing, frame **975**, with the proximal ends of the attachment struts **955** fixed to the proximal connecting member **970**. In this embodiment the filter media support struts **985** closest to the proximal connector also function as the closed support member described herein to provide the transverse dimension of the frame and support the proximal end of the filter **960**. **Figure 9C** illustrates the annealed filter frame pattern **975** of **Figure 9B** and filter media **960** attached to a guidewire **980**.

Figure 10A illustrates a two-dimensional view of an alternate seamless filter pattern **1015** having attachment struts **1055** and a central portion of the planar Nitinol precursor material **1010** rendered porous **1090**. **Figures 10B** and **10C** illustrate three-dimensional views of the filter frame pattern **1015** of **Figure 10A** after annealing, frame **1075**, with the proximal ends of the attachment struts **1055** fixed to the connecting member **1070**, and the porous precursor material **1090** having pleats **1095**. **Figure 10C** illustrates the annealed filter frame pattern **1075** of **Figure 10B** attached to a guidewire **1080**. A separate filter media is not necessary in the embodiment illustrated in **Figures 10A- 10C** because the porous precursor portion **1090** serves as the filter media.

Figure 11A illustrates a two-dimensional view of an alternate seamless filter pattern **1115** having attachment and filter strut **1156** which will also function as the closed support member **1156A** shown in **Figure 11B**. **Figures 11B** and **11C** illustrate three-dimensional views of the filter frame pattern **1115** of **Figure 11A** after annealing, frame **1175**, with the proximal end of the closed support member **1156A** fixed to the connecting member **1170**. **Figure 11C** illustrates the annealed filter frame pattern **1175** of **Figure 11B** with filter media **1160** attached to a guidewire **1180**.

Although the above embodiments show a single support member **156A, 256A, 356A, 456A, 556A, 656A, 756A, 956A**, etc., it is clearly within the scope of the invention to have a plurality of longitudinally spaced support members, i.e., members that circumscribe the longitudinal axis of the frame, that are seamlessly interconnected with one another via struts or articulation segments, as in **Figure 7E**. Similarly other embodiments described hereinafter may also include a plurality of seamlessly interconnected support members where the mechanism for interconnection includes struts, and/or the articulation segments which are defined hereinafter. In addition, when there are more than two support members connected to one another, some or all may be interconnected with struts and some or all may be interconnected via articulation segments. Thus, there could be a series of two, three, four or more members, and in the case with at least three support members that circumscribe the pattern's longitudinal axis, both struts and articulation segments can be used in an alternating pattern.

Figures 12A, 12B, 12C, 12D and 12E illustrate alternate configurations of stent strut, and apex designs which allow for, accept and house ancillary components. **Figure 12A** depicts a housing **1210**, which could be machined, stamped, lasered or etched into the stent frame. Housing **1210** is then filled with a material **1250** such as gold or platinum-iridium (to provide enhanced radio-opacity) or with a therapeutic agent such as a drug (to provide a prescribed biological response). **Figure 12B** depicts housing **1210** located along the side of a strut. **Figure 12C** depicts multiple housings **1210** along a strut. **Figure 12D** depicts multiple housings **1210** located within the strut periphery. **Figure 12E** depicts an alternate

shape (arrowhead) housing **1210** (to be used as a radiopaque marker housing) located within the strut periphery. It should be noted that multiple shapes and sizes of housings could be configured. The radiopaque markers could be located in any strut or support member of the frame of the filter or the stent. Advantages of the application of radio-opaque markers in the fashions shown are: 1) stent cross section thickness is not increased (lending to reduction in introductory device profiles), 2) allows for precise and uniform spacing of markers, and 3) allows for a multitude of shapes (dots, arrows and other characters such as letters or words) to be easily incorporated into the frame. The housings may also provide a cavity in which to insert and/or attach onboard electronics or sensors.

Figure 13 illustrates an embolic filter assembly system **1300** that includes three functionally distinct regions. Section **1300A** includes a support wire that terminates at its distal end in connecting member **1370**. The support wire may be the guidewire **1380** used to deliver a therapeutic device, e.g., a deployment catheter or angioplasty balloon. Section **1300B** is any one of the embolic filter devices described in **Figures 1A-1E** through **11A-11C** described herein, or another other device described hereinafter. Section **1300C** may include an atraumatic tip **1396** or other suitable tip known to those skilled in the art having a proximal end fixed/attached/cooperating with distal connecting member.

Figure 14A depicts the filter apparatus **1400** as deployed in a vessel **1420** with tortuous anatomy. As shown, such a condition results in a non-linear apparatus deployment configuration. In order for filter frame **1410** to maintain sufficient vessel wall apposition (which eliminates peri-device channel formations), the tether elements **1430** must be capable of deforming and/or articulating.

Figure 14B depicts the filter apparatus **1400** as deployed at a different site within the same vessel **1420** anatomy of **Figure 14A**, once again demonstrating the flexibility required of the deflecting and articulating tether elements **1430**. It is clear in this depiction that the guidewire **1440** does not necessarily follow the host vessel centerline. This phenomenon, coupled with anatomical variances and the requirement of complete vessel wall apposition of the filter frame **1410** makes the inclusion of articulating tether elements **1430** a benefit and necessity for safe and confident embolic protection of downstream vasculature.

Figure 15 illustrates an arrangement to attach a filter media to any of the annealed filter frames described herein. The frame **1515**, is sandwiched between filter media portions **1560A** and **1560B**, which are respectively sandwiched between cushion elements **1500C** and **1500D**, which layered assembly is located between heated top plate **1500A** and heated base plate **1500B**. Thus, resulting three-dimensional lamination of **Figure 15** has a cross-sectional view that is substantially conical. Application of heat and pressure, via heated platens **1500A** and **1500B**, result in the integral bonding of the filter media **1560A** and **1560B**, and the interposed frame **1515**. The filter frame configuration via the lamination

procedure depicted in **Figure 15** results in a filter assembly configuration resembling a “butterfly net.”

Figure 16 schematically shows an alternate procedure for attaching filter media to an annealed filter frame. In **Figure 16**, an annealed filter frame **1615** is sandwiched between adjacent laminae of inner filter media **1660A** and outer filter media **1660B**. Heat and pressure are applied via upper and lower punch and die platens **1600A** and **1600B**. The application of heat and pressure results in an integral bonding of the filter media **1660A** and **1660B** and interposed frame **1615**. During the heating and pressure lamination process, a vacuum may be applied in the lower platen **1600B** thereby bonding the filter media and skeletal filter frame together. The filter media shown in **Figure 16** is normally interposed only within the immediate vicinity of the filter frame **1615**. Additionally, the application of the vacuum can be used to optimize the filter frame geometry. The method shown in **Figure 16** can produce a filter frame configuration that resembles a butterfly net, such as the one shown in the device of **Figures 7A–7C**. This method can also be used to produce a frame-supported “filter-in-filter,” which is shown in further detail in **Figure 17**, described below.

Figure 17 shows an alternate embodiment of the present invention incorporating a two stage “filter-in-filter” design. The filter-in-filter design will provide improved filtration efficiencies, such as allowing each filter lamina to have a different porosity by using an inner filter media **1760A** and an outer filter media **1760B**. Alternatively, either filter media **1760A** or **1760B** can incorporate an integral Nitinol frame as one of the filter members. Alternatively still, both the inner and outer filter media **1760A** and **1760B** could be an integral Nitinol filter frame. Use of an uni-body Nitinol frame, such as those described herein, would provide additional structural benefits in the completed filter frame apparatus.

Figures 18A, 18B, and 18C schematically illustrate an annealing method in which a planar, two-dimensional filter frame is converted into a three-dimensional configuration with the use of an appropriate fixturing/tooling device, e.g., a mandrel. Mandrel **1800A**, shown in **Figure 18A**, is used to form the filter frame **1815** of **Figure 18B** into the desired shape. After cutting a flat metal sheet into the desired two dimensional configuration, such as that described above, the proximal ends **1865** of attachments struts **1855**, i.e., the endpoints of the two-dimensional filter frame **1815**, are collected at a point along the axis of radial symmetry as shown in **Figure 18B**. As depicted in **Figure 18C**, the filter frame **1815** is placed onto the fixturing device, which, in this case, is the mandrel **1800A** of **Figure 18A** to impart a defined, three-dimensional configuration, and the frame **1815** of **Figure 18B** is annealed to preserve the desired configuration. After annealing, the three-dimensional filter frame **1875** can be elastically deformed into its original two-dimensional shape where a filter media can be applied according to any of the methods described and illustrated herein.

Following the attachment of the filter media, the three-dimensional filter configuration is readily obtained.

Figures 19A, 19B, 19C and 19D illustrate an alternate filter configuration using a “sombbrero” shaped filter media **1960B** with a supporting frame. To form the sombrero frame and filter shown in **Figure 19D**, a conical filter **1960**, as shown in **Figure 19A**, has its closed distal end **1962** inverted toward the open proximal end **1961** of the conical filter **1960**, to form a convex, hat-like base as shown in **Figure 19B**. This inversion shortens the filter length, but retains the original area of the filter element **1960**. Next, the convexity is increased until the apex **1963** extends beyond the open end **1961**, as shown in **Figure 19C**. The filter **1960** thus has been shortened further, but the effective filter area still remains identical to the original conical filter area. The sombrero filter **1960B** is attached to frame **1975**, **Figure 19D**. The frame includes attachment struts that are fixed to a connecting member **1970**, which in turn is cooperatively associated with a guidewire **1955**. Compared to conventional conical filter frame designs, the sombrero filter frame allows more surface area per unit length, or, alternatively, reduces filter length without compromising filter surface area and deflection of the trapped debris away from the vessel centerline. The desired sombrero filter frame configuration will also increase the reliable removal of entrapped debris.

Figures 19E and 19F depict an alternate filter sack configuration, also designed to collect and hold embolic debris away from the vessel centerline. In this case, an asymmetric cone shaped filter media sack **1990** is produced and attached to the filter frame **1960**. Collected emboli will tend to collect at the tip of the sack **1990** and are held offset in the vessel, thus allowing relatively unperturbed flow at the vessel centerline.

As shown in **Figures 20A, 20B and 20C**, a filter in accordance with the present invention can be used to deliver a pharmaceutical substance, anti-thrombotic agent, drug, etc., into the blood flow in a host lumen/vessel by deploying the filter in a lumen/vessel of interest. In **Figure 20A**, a filter device such as that described in **Figure 17** above, can be loaded with a pharmacological agent in one or more different areas before delivery into the host. Thus, the drug can be loaded between layers of the filter media. The drug **2098** may be retained within the zone/space/area between the inner filter media **2060A** and outer filter media **2060B** ready to be delivered to the host.

Instead of using the filter-in-filter design of **Figure 17**, any of the other filter configurations described herein can be used by imbibing the drug into the filter media itself. As shown in **Figure 20B**, the drug **2098** can be imbibed into the media **2060** itself.

Figure 20C illustrates drug administration in the host by deploying the drug delivering system of **Figures 20A or 20B** in a host lumen/vessel so that the blood flows through the filter media to elute the pharmacological agent, e.g., drugs. This method of localized drug

delivery is effective for eluting a pharmacological agent contained either between adjacent layers of filter media or imbibed directly into the filter media. Fluid flow through the filter device of **Figures 20A** or **20B**, or any other filter configuration described herein containing pharmacological agents provides a mechanism of mass transfer to downstream perfusion beds. The pharmacological agent could be pre-loaded into the filter or injected post deployment perhaps through an extension of the support/guidewire.

As shown in **Figures 21A** and **21B**, occluding device **2175** can be formed as a detachable endoluminal filter frame that can be implanted in the host. The occluding device **2175** thus implanted can either be permanently implanted or retrieved at a later point in time, such as is required in vena cava filtering applications. As shown in **Figure 21A**, blood flow through the host can be obstructed by the implantation of the filter frame apparatus **2100**. The filter frame apparatus **2100**, used as an indwelling or implantable occlusion device is shown in **Figure 21A**. As shown in **Figure 21B**, a guidewire or support wire **2180** includes a distal end **2181** that may be detached from proximal connector **2170** that is connected to the occluding device **2175** or filter frame apparatus **2100**. The support wire **2180** is used to position or remove occluding device **2175** or filter frame apparatus **2100** from a lumen in a host. The guidewire tip **2181** may be of any design for detachment from or reattachment to proximal connector **2170**. Thus, the guidewire **2180** can have any capture capability, including screw threads, magnetic, ball-and-socket, male-female attachment, bayonet, or any type of coupling that will allow the guidewire **2180** to detach or reattach to the proximal connector **2170** for placement or movement therein.

Figures 22A and **22B** illustrate the use of a filter (similar to the filters **100** or **700**, respectively shown in **Figures 1D** or **7C**) to remove flow obstructions or to function as a thrombectomy device to remove intraluminal thrombus, for example. **Figure 22A** shows an obstruction at the lumen wall in a blood vessel of the host. Though commonly the lesion will have formed in a restrictive manner, the lesion is shown in a cross-sectional area with an upper and a lower component, that has narrowed the effective diameter of the lumen. Filter **2200** includes sharpened support members **2285** to enable the filter to be used as a type of scraper. The frame **2275** shown herein includes a filter media **2260** as a "catch bag." In **Figure 22B**, the filter **2200** is pulled with sharpened members **2285**, effectively shearing the obstruction/lesion from the vessel wall of the host. As the lesion is sheared from the wall, sheared lesion parts are collected in the catch bag or filter media **2260**. In this manner, the present filter frame can be used to remove lesions and collect the debris dislodged into the blood stream, to lessen the possibility of clotting downstream of the host vessel. This approach can likewise be used to capture and remove foreign objects from bodily passageways.

Figures 23A, 23B and 23C respectively illustrate the use of the inventive filter as an anchoring guidewire to facilitate the retention of a guidewire position in tortuous vessels of the renal circulatory system, and in particular for branch lumens offset at angles of approximately 90°. Using the inventive filter frame as an anchor avoids or minimizes damage to the host vessel, and specifically avoids or minimizes damage to the endothelium of the host lumen/vessel. **Figure 23A** shows a lesion **2300A** in a branch lumen/vessel **2300B** associated with the renal anatomy of a host. In the non-limiting embodiment of **Figures 23A – 23C**, the branch lumen **2300B** includes an approximate 90° turn toward the existing anatomy shown. As illustrated in **Figure 23B** a filter frame **2375** is positioned and anchored in a renal circulatory vessel **2300B** to fix the position of the support wire **2380**. A slight pressure is imposed on the support wire **2380** and the approximate 90° turn is extended to more than 90° without dislodging or altering the position of the guidewire in relation to the host anatomy as shown in **Figure 23B**.

As shown in **Figure 23C**, a therapeutic catheter **2300C** can be inserted over the support wire **2380** of the filter frame to perform the intervention. As a result, therapy devices can more easily negotiate a greater than 90° bend as shown in **Figures 23B and 23C**. Such therapy devices include, but are not limited to balloons, stents, etc. A further useful aspect of this embodiment is that, during its use, a long “exchange length” guidewire is unnecessary. Since this device is capable of maintaining its positioning after deployment, the necessity of “rapid exchange” or “monorail” catheters are obviated.

Figures 24A, 24B, 24C, 24D and 24E show a further embodiment of the present filter frame assembly, which is intended to function as an implantable endoprosthesis **2476**. As shown in **Figures 24A and 24B**, the initial seamless filter frame **2475** is formed from a loop-type frame **2415** from the same precursor material. In **Figure 24C**, the proximal end of an open-ended “windsock” shaped graft component **2477** is attached to the loop of the filter frame **2475** to form an endoprosthesis **2476**. In **Figure 24D**, the loop-type frame **2475** with the attached open-ended windsock is deployed proximal to an aneurysmal defect, and the windsock shaped graft component **2477** extends downstream of the frame, effectively excluding the aneurysm **2400A**. Thus, frame and the opened ended sock function as an implantable prosthetic vascular conduit where the filter frame **2475** functions as an anchoring stent, and the open-ended sock functions as a biocompatible liner. This device, shown in **Figure 24E**, may then be optionally lined with a stent **2480**. This embodiment finds use as a stent and graft combination where the stent element would be deployed proximal to the intended therapy site and the graft element would be configured to be deployed by blood pressure.

Figures 25A–25H illustrate an exemplary delivery system for deploying the present filter frame **2575** or filter **2500** of the present invention. **Figure 25A** illustrates a frame **2575**

or frame-filter **2500**, such as frame **175** or frame-filter **100** of **Figures 1D** or **1E**, frame **375** or frame-filter **300** of **Figures 3B** and **3C**, or any of the other frame or frame - filter assembly herein described, attached to a support or guidewire **2580** and positioned within a tubular delivery sheath **2500A** of a delivery catheter. **Figures 25B-25D** illustrates front views taken from sectional plane A-A of **Figure 25A**, but without the frame **2575** or frame-filter **2500**. The section A-A1 (**Figure 25B**) illustrates a dual lumen extrusion catheter sheath. Section A-A2 (**Figure 25C**) illustrates a single lumen extrusion having an additional covering formed from a shrink tube. Section A-A3 (**Figure 25D**) illustrates a second lumen adhered to the inner diameter of the tubular delivery sheath **2500A** of **Figure 25A**.

Figure 25E – 25H illustrate the perspective detail of external guidewire **2580** loading of a catheter lumen. **Figure 25E** is a front view of the **Figure 25G**. **Figure 25F** illustrates the catheter having a longitudinally extending indented channel, which, as seen in **Figure 25G** is circumscribed by a tubular section **2500C**. The guidewire **2580** is inserted into the longitudinally extending channel **2500B** between the external wall of the catheter and the tubular section **2500C**. In use, a filter frame or filter-frame construct is pre-loaded into the distal end of the sheath adjacent to an exterior wire guide channel. The exterior wire guide is adapted to receive a guidewire in a rapid exchange configuration, however, unlike the prior art, the filter frame and guidewire **2580** are completely segregated and no aperture exists.

Figures 26A, 26B, 26C, 26D and **26E** illustrate a method of using a filter frame assembly **2600** in accordance with the present invention. In **Figure 26A**, a lumen/vessel **2600A** of the host has a lesion **2600B**. A guidewire **2680** is deployed into the lumen/vessel **2600A** past the target lesion **2600B**. Thereafter, guidewire **2680** is back-loaded into the delivery system **2600C**, such as the one described in **Figures 25B-25D, 25F-25G**, or **Figure 27B**. Then the delivery sheath **2600C** is advanced across the target lesion **2600B**. The delivery sheath **2600C** is withdrawn, thereby allowing a self-expanding filter **2600** to deploy. The self-expanding filter **2600** is normally designed to deploy spontaneously after the delivery sheath **2600C** has been withdrawn in this manner. Thus, as shown in **Figure 26C**, the filter **2600** is deployed downstream of the lesion **2600B**. A therapeutic catheter **2600D**, such as an angioplasty balloon, is routed over the support wire **2680** in **Figure 26D** to treat target lesion **2600B**. As also shown in **Figure 26D**, when the therapy is performed, the filter **2600** functions to capture any emboli dislodged or removed by the therapeutic catheter **2600D**. Thereafter, as illustrated in **Figure 26E**, the filter **2600** is removed via insertion of a tubular capturing catheter **2600E** over the support wire and retraction of the filter **2600** into the capture catheter **2600E** is performed. This retraction can be performed by pulling the filter **2600** partially back into the capture catheter lumen **2600E**, effectively trapping the

emboli **2600F**. In this manner, the lesion is dissipated through a therapeutic catheter without the result of any of the dislodged emboli or debris dislodging into the host.

Figures 27A, 27B and 27C illustrate a lumen **2710** having an auxiliary, internally positioned channel **2720** for receiving a guidewire **2730**. **Figure 27A** illustrates the tip of the sheath having an internally located, peripherally positioned auxiliary channel **2720** formed by "pinching" the end of the tube wall as shown in **Figure 27B**. **Figure 27C** shows the guidewire **2730** inserted through into the slit opening in the side of the catheter and exiting the tip.

Figure 28 illustrates the use of the inventive filter **2800**, as a vena cava filter. Since the inventive filters described herein may be readily detachable, the filter **2800** can be readily detached from a deployment guidewire.

Figure 29A illustrates a planar two-dimensional seamless pattern, formed from metallic material, or any other suitable biocompatible material. **Figure 29B** illustrates a three-dimensional stent member formed from the planar two-dimensional pattern of **Figure 29A**, for use as an intraluminal stent. When extremely thin wall sections are required, such as in coronary stents, it is appropriate to fabricate the device from a planar sheet of material. Planar material can be manufactured thinner than tubing due to the extra requirements of concentricity placed upon tubing stock. It should be noted that although only one design has been depicted, a wide variety of patterns and cell geometries may be produced from planar material. The various cell geometries are defined by the interconnected struts of the stent. In **Figures 29A and 29B** four interconnected struts **2910** define the four sided cell **2920**. This planar material may be metallic or polymeric or a combination thereof, and in any case, may also be porous. Once the flat pattern is fabricated, it is formed into a 3-D shape (in the depicted instance, an open mesh tube). The formed stent may be either plastically deformable (and thus made from a malleable starting material) or may be self-expanding, in which case a super-elastic, pseudo-elastic or shape memory material may be used. Subsequent processing such as thermal treatment, diametric reduction, de-burring and polishing may be incurred, depending upon the specific stent design. It should be understood that multiple 3-D stent "units" could be manufactured in such a way and attached together to form a much longer device.

Figure 30 depicts a view of a flat pattern of filter frame **3010A** and integral tether element **3010B** geometry as it would be cut from a tube. This tube may be made of a shape memory alloy such as Nitinol. Cutting could be accomplished by a variety of methods including machining, laser cutting, stamping or etching.

Figure 31 depicts the flat pattern geometry of **Figure 30** subsequent to forming and annealing at a larger, functional size. Upon annealing, the filter frame **3010A** resiliently

maintains this larger diametrical profile and the at least one tether element **3010B** extends seamlessly from it.

Figures 32A-32E depict alternate articulation segments formed as an integral part of the tether element thereby forming different tether element geometries, which allow articulation of the tether elements **3010B** in relation to the filter frame **3010A**. **Figure 32A** depicts the tether element **3010B** with an area of reduced strut width e.g. reduced cross-sectional area, to allow increased flexibility. **Figure 32B** depicts tether element **3010B** with several individual areas of reduced strut width to allow increased flexibility. **Figure 32C** depicts tether element **3010B** with a reduced width and formed "hinging" area to increase flexibility. **Figure 32D** depicts tether element **3010B** with a reduced width and several formed "hinging" areas to increase flexibility. **Figure 32E** depicts tether element **3010B** divided in two for a portion of its length. This division effectively increases the tether element flexibility so as to allow articulation. The articulation segment of the tether element, therefore, is configured to enhance the flexibility of the filter apparatus (and thus, conformance to the host vessel wall) as well as to minimize inadvertent trauma translated to the host vessel wall by movement or manipulation of the guidewire.

An articulation segment of the tether elements or struts is a desirable feature in that it allows adequate vessel wall apposition of the filter frame when the filter device is deployed in a curved segment of anatomy. In a curved segment, the tether element articulates and deflects to adjust for a non-linear deployment situation (See **Figure 14**). Thus, the filter frame itself can maintain an uncompromised and fully deployed condition. Likewise, because of its ability to attenuate longitudinal translation, the articulation segment provides a means of mitigating trauma of the host vessel wall due to guidewire manipulation. It should also be noted that the required deflection and articulation of the tether elements could be brought about by metallurgical means rather than, or in combination with, geometrical means. For instance, the tether **3010B** and frame **3010A** elements of **Figures 32A-E**, although seamless and integral, may be exposed to different thermal processing parameters (for example: through the use of fixturing to provide differential heat sink qualities), thus rendering the tether **3010B** ductile and pliable while the frame **3010A** maintains the stiffness required for adequate vessel wall apposition.

The articulation segments, though described with respect to the various frame patterns can be incorporated into any of the endovascular devices described herein. An articulation segment is a localized region that provides enhanced longitudinal flexibility. A localized region may have a cross-sectional area that is the same as the remaining part a strut, but differs in geometry. Alternatively, the localized region could have the same geometry but a different cross-sectional area, or both the cross-sectional area and geometry

of the localized region differ from the remaining part of the strut. An endovascular stent can have articulation segments in any of the interconnected struts of **Figures 29A** and **29B**.

EXAMPLES OF THE PRESENT INVENTION:

EXAMPLE 1: Nitinol Sheet Filter Frame and integral Tethers

A radially-symmetric geometrical pattern comprising interconnected struts forming closed polygonal shaped cells was chemically etched from a sheet of Nitinol (NiTi) to produce a skeletal filter frame. The etching, preferably photoetching of Nitinol (Kemac Technologies, Irwindale, CA) is continued to achieve a desirable material thickness, to optimize the moment of inertia of the struts and to polish the surface finish.

This filter frame is then subjected to a thermal treatment to set the phase transition temperature of the NiTi to approximately 37°C by heating the filter frame to a temperature of about 450°C for about 10 minutes in an air convection oven (Carbolite Corporation, Sheffield, England) followed by a rapid quench in ambient temperature water.

The NiTi filter frame was then laminated between two (2) layers of an adhesive-coated porous polymer. The layers were positioned with the adhesive sides facing toward each other, and facing toward the NiTi. The adhesive was used to adhere the layers of film together as well as to the NiTi wire framework. A sacrificial porous polymer cushion material was used on each side of the device during this lamination procedure to provide compliance of the surface during compression. This compliance allows the earlier mentioned porous polymer membrane to conform to the wire shape. The composite sub-assembly which included cushion, porous polymer/adhesive laminate, NiTi, adhesive/porous polymer laminate, and cushion layers was then compressed in a SST fixture and heat treated at 320°C for 45 minutes in an air convection oven (Grieve Oven, The Grieve Corporation, Round Lake, IL).

Once the 'sandwiched' device was removed from the heat source and allowed to cool, the sacrificial cushion material was peeled away from each side of the device and the NiTi wires were disengaged from the fixture. A circular shape of approximately 0.625" in diameter was trimmed into the porous polymer using a 20-watt carbon dioxide laser. The remainder of porous polymer was trimmed from the wire frame by hand and discarded.

Following the laser trimming operation (which can also be used to create the necessary pores in the filter media), the radially-oriented arms (struts) of the device were folded up and back on themselves to achieve a hollow, three dimensional, semi-conical shape. To maintain the device in this configuration, the NiTi struts were inserted into a SST tube. This tube measured approximately 0.05" in length X 0.035" outer diameter X 0.025" inner diameter. This tube and indwelling NiTi wires were then crimped to a 0.014" diameter

guidewire to provide a guidewire based endoluminal embolic protection device. The device resembled a three dimensional "whisk" shape with a pleated porous polymer filter element attached to it.

The resulting pleats are designed to increase filter media surface area over the generally conical shapes found in the prior art. This increase in surface area also allows for a shorter filter length which enhances deliverability of the device by a) decreasing friction in the delivery catheter and b) improving device overall flexibility.

EXAMPLE 2: Nitinol Tube Filter Frame and Integral Tethers.

A 1.3 mm Nitinol tube with a wall thickness of approx 0.1mm (obtained from Nitinol Devices and Components, Fremont, CA) was laser cut (Lasera Technology Inc, Waukegan, IL) to a single, undulating 6 apex ring geometry with integral tethers. This frame was then lightly grit blasted at 40 psi with 20 micron silicon carbide media in a grit blasting machine made by Comco Inc, Burbank, CA. The ring with integral tethers was then gently pushed up a tapered mandrel until it achieved a functional size of approx. 6mm. The ring, tethers and mandrel were then subjected to a thermal treatment to set the phase transition temperature of the NiTi to approximately 37⁰C in an air convection oven (Carbolite Corporation, Sheffield, England) One skilled in the art will realize that variances in the geometry, metallurgy, thickness and heat treating of the filter frame can all be varied to create alternate embodiments with varying desirable properties. The ring and tethers (now at functional size) were then lightly coated with a fluorinated ethylene propylene (FEP) powder (FEP 5101, available from Dupont Corp, Wilmington, DE) by first stirring the powder in a kitchen blender (Hamilton Beach Blendmaster, Wal-Mart) after the powder was mixed into a "cloud", the frame was hung into the blender for enough time for FEP to build up onto the surface of the ring. The frame, now coated with FEP powder was hung in an air convection oven (Grieve Oven, The Grieve Corporation, Round Lake, IL) set at 320⁰C for approx. one minute followed by air cooling to room temp.

The NiTi frame was then set atop a filter sack and attached through the application of localized heat (the heat causing the FEP coating on the ring to re-melt and flow onto the surface of the filter sack, thus providing a biocompatible thermoplastic adhesive). The tether lines were then routed through a gold tube (Johnson Matthey, San Diego, CA) radiopaque marker. The tethers were pulled until they began to apply tension to the frame. A guidewire was then inserted into the gold band (from the opposite direction of the tether lines). The marker band was then crimped to secure the tethers and guidewire together. A small amount of instant adhesive (Loctite 401, Loctite Corp, Rocky Hill, CT) was applied to create a smooth transition from the guidewire to the OD of the gold band. One skilled in the art will

realize that attachment of the filter to the guidewire could be accomplished by adhesion, welding, soldering, brazing, a combination of these, or a number of other methods.

Upon drying, this embodiment of the endoluminal embolic filter is ready for testing.

Various illustrative examples of the invention have been described in detail. In addition, however, many modifications and changes can be made to these examples without departing from the nature and spirit of the invention.

CLAIMS:

What is claimed is:

1. A filter comprising:
a seamless frame having a proximal end and a longitudinal axis, said frame having a seamless support member circumscribing said axis and distally spaced from said proximal end, said support member having at least one attachment strut seamlessly extending therefrom and terminating at said proximal end, and a filter media having an open, proximal end cooperating with said support member and a closed end extending distally away from said open end and defining the end of said filter.
2. The filter according to claim 1 further including at least one filter strut seamlessly extending distally from support member and having a mid-point that is distally spaced from said support member, said at least one filter strut engaging and supporting said filter media.
3. The filter according to claim 1, wherein said at least one attachment strut comprises a plurality of attachment struts each seamlessly extending from said support member and terminating at said proximal end.
4. The filter according to claim 2, wherein said at least one filter strut comprises a plurality of filter struts seamlessly extending distally away from said support member.
5. The filter according to claim 1, further including a plurality of filter struts seamlessly extending distally away from said support member.
6. The filter according to claim 2, wherein there are at least two filter struts.
7. The filter according to claim 2, wherein there are at least three filter struts.
8. The filter according to claim 3, wherein there are between 4 and 12 filter struts.
9. The filter according to claim 3, wherein there are at least 6 filter struts.
10. The filter according to claim 3, wherein there is between 6 and 18 filter struts.

11. The filter according to claim 1, wherein said at least one attachment strut and said support member are respectively formed from different portions of a helically configured frame having multiple turns, with one turn forming said support member.
12. An endovascular device comprising:
a seamless frame having a proximal end, a distal end and a longitudinal axis extending therebetween, said frame having a seamless support member circumscribing said axis and located between said proximal and distal ends, a first set of struts extending seamlessly from said support member towards said proximal end and a second set of struts extending seamlessly from said support member towards said distal end.
13. The device of claim 12, wherein at least one strut of said first and second struts sets includes radiopaque markers.
14. The filter according to claim 1, wherein said filter media includes a plurality of filter media layers.
15. The filter according to claim 14, wherein there are two filter media layers which are separated from one another.
16. The filter according to claims 1, wherein the filter media includes a pharmacological agent.
17. The filter according to claim 14, wherein at least one of said layers includes a pharmacological agent.
18. The filter according to claim 15, wherein a pharmacological agent is located in a space between the separated filter media layers.
19. The filter according to claim 14, wherein each of said plurality of filter media layers possesses different physical or chemical properties.
20. An endovascular device comprising:
a seamless frame having a proximal end, a seamless circular support member having a proximally and seamlessly extending attachment strut terminating in a proximal connecting end, and a biocompatible, open ended tubular member having a proximal end attached to said support member.

21. The device according to claim 20, wherein said tubular member has a symmetrically tapered terminal end similar to a windsock.
22. The device according to claim 20, wherein said tubular member is an endovascular graft.
23. The filter according to claim 1, wherein said filter media is sombrero shaped.
24. The filter according to claim 1, wherein said filter media is conically shaped.
25. The filter according to claim 1, where said support member and said at least one attachment strut is formed from a biocompatible material.
26. The filter according to claim 25, wherein the biocompatible material is self-expanding.
27. The filter according to claim 25, wherein the biocompatible material is a polymer.
28. A method of constructing a uni-body, self-expanding filter frame comprising:
extracting a substantially two-dimensional filter frame pattern from common planar sheet of precursor material by cutting;
configuring said two-dimensional pattern into a three-dimensional configuration; and
thermally annealing said three-dimensional configuration.
29. The method according to claim 28, wherein said pattern includes attachment struts and support struts.
30. The method according to claim 28, wherein said pattern includes attachment struts, support struts and filter support struts.
31. The method of claim 29, wherein the precursor material is a shape memory alloy.
32. The method according to claim 28, wherein the two-dimensional filter frame has at least one closed cell, the at least one cell including an area that has a circumference defined by a seamlessly continuous ribbon or strut of the same precursor material.

33. The method according to claim 28, further comprising attaching a filter media to the filter frame before or after annealing.
34. The method according to claim 33, wherein the filter media includes a pharmacological agent.
35. The method of claim 28, wherein a portion of said anneal frame is positioned between two layers or portions thereof of filter media and the layers assembly laminated together.
36. A method of attaching a biocompatible, permeable filter media to a three dimensional filter frame comprising:
providing a three-dimensional filter frame;
deforming the three-dimensional frame into a substantially planar, two dimensional configuration; and
adhering at least one layer of filter media on the frame.
37. A method of assembly a filter comprising
providing a conical filter element;
providing a three-dimensional seamless filter frame; and
laminating said filter element and frame together.
38. The filter according to claim 3, wherein said plurality of attachment struts include at least one integral articulation segment.
39. The filter according to claim 38, wherein said at least one integral articulation segment includes a geometrically altered cross-sectional attachment strut section.
40. The filter according to claim 38, wherein said at least one integral articulation segment includes a zig-zag or undulating configuration.
41. The filter according to claim 2, wherein at least one filter strut includes a radiopaque marker.
42. The device according to claim 21, wherein said tubular member has an asymmetrically tapered terminal end.

43. The filter according to claim 1, wherein said filter media is asymmetrically cone shaped.
44. A method of constructing a uni-body, frame comprising:
extracting a substantially two-dimensional plastically deformable frame pattern from a common planar sheet of plastically deformable material by cutting;
configuring said two-dimensional pattern into a three-dimensional configuration; and
thermally treating said three-dimensional configuration.
45. A method of constructing a uni-body, self-expanding frame comprising:
extracting a substantially two-dimensional frame pattern from a common planar sheet of a shape-memory alloy, self-expanding material by cutting;
configuring said two-dimensional pattern into a three-dimensional configuration; and
thermally annealing said three-dimensional configuration.
46. The method according to claim 29, wherein said attachment struts have at least one articulation region.
47. The method according to claim 30, wherein said filter struts are adapted to incorporate a radio-opaque marker without adding thickness.
48. The method according to claim 44, wherein said pattern includes attachment struts and/or support struts.
49. The method according to claim 44, wherein said pattern includes attachment struts, and/or support struts and/or filter support struts.
50. The method according to claim 45, wherein said pattern includes attachment struts and/or support struts.
51. The method according to claim 45, wherein said pattern includes attachment struts and/or support struts and/or filter support struts.
52. The method according to claim 49, wherein any of said struts are adapted to incorporate a radio-opaque marker without adding thickness.

53. The method according to claim 51, wherein any of said struts are adapted to incorporate a radio-opaque marker without adding thickness.
54. The filter according to claim 3, wherein said at least one attachment strut includes metallurgical articulation segments.
55. The filter according to claim 3, wherein said at least one attachment strut includes different articulation segments.
56. The filter according to claim 1, wherein said at least one attachment strut includes at least one seamless and integral articulation segment.
57. The filter according to claim 56, wherein said at least one seamless and integral articulation segment includes a geometrically altered cross-sectional attachment strut section.
58. The filter according to claim 1, wherein said at least one attachment strut includes at least one seamless and integral metallurgical articulation segment.
59. A filter comprising:
a seamless frame having a proximal end and a longitudinal axis, said frame having a seamless support member circumscribing said axis and distally spaced from said proximal end, said support member having at least one attachment strut seamlessly extending therefrom and terminating at said proximal end, and at least one filter media having an open, proximal end cooperating with said support member and a closed end.
60. A device comprising:
a seamless frame having a proximal end, a distal end and a longitudinal axis extending therebetween, said frame having at least one seamless support member circumscribing said axis and located between said proximal and distal ends, at least one of a first set of struts extending seamlessly from said support member towards said proximal end and at least one of a second set of struts extending seamlessly from said support member towards said distal end.
61. The device according to claim 60, wherein a plurality of seamless support members circumscribe said axis.

62. The device according to claim 60, wherein at least one of said struts of said first and second sets of struts and said at least one support member includes at least one of an integral articulation member and a radio-opaque marker.
63. The device according to claim 60, further including at least one seamless and integral articulation segment.
64. The device according to claim 62, further including a plurality of circumscribing members, and at least one integral articulation segment, one of which seamlessly interconnects said members.
65. An endovascular device comprising:
a seamless frame having open proximal and distal ends and a plurality of seamless integral struts formed from a common precursor material, at least some of said struts being seamlessly interconnected with one another to define a plurality of closed cells, and at least one of said plurality of seamless struts optionally having at least one articulation segment and/or radiopaque marker.
66. The device according to claim 65, wherein same frame is a tubular stent.
67. The device according to claim 65, wherein said frame includes integral articulation segments.
68. The device according to claim 65, wherein said frame includes radiopaque markers.
69. The device according to claim 65, wherein said frame includes integral articulation segments and radiopaque markers.
70. The filter according to claim 5, wherein said distally extending filter struts terminate at a common seamless distal end.
71. The filter according to claim 12, wherein said distally extending filter struts terminate at a common seamless distal end.

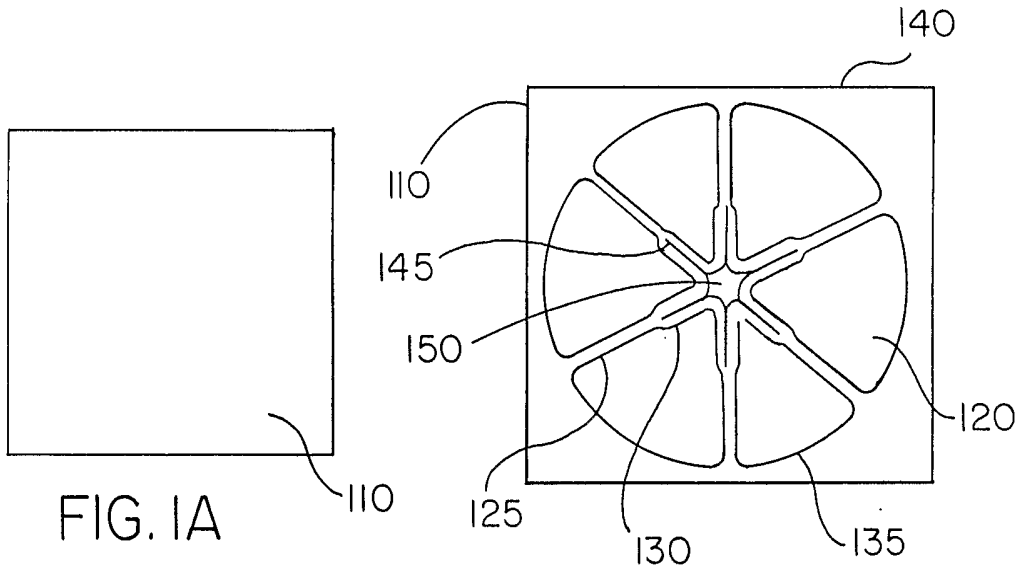

FIG. IA

FIG. IB

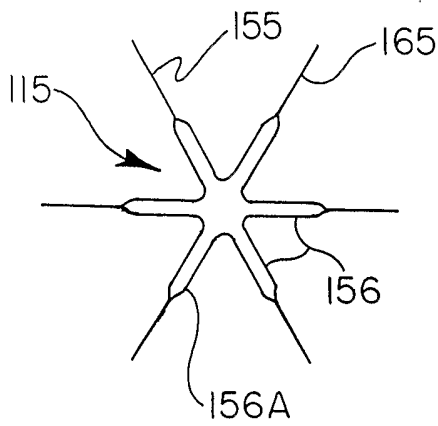

FIG. IC

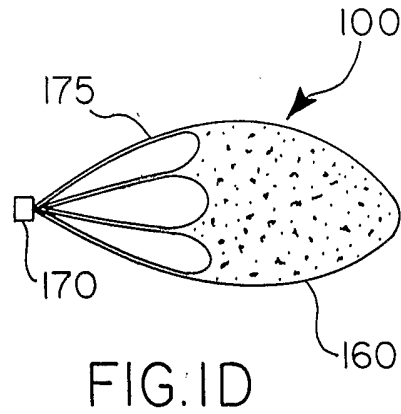

FIG. ID

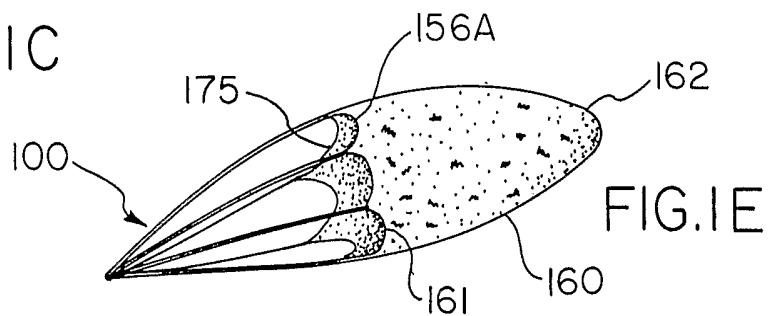

FIG. IE

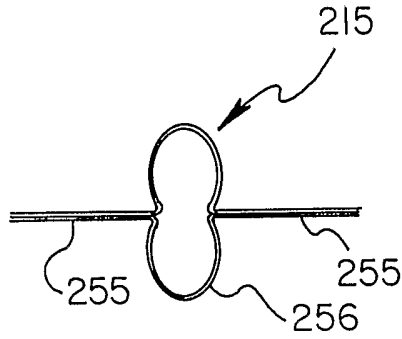

FIG. 2A

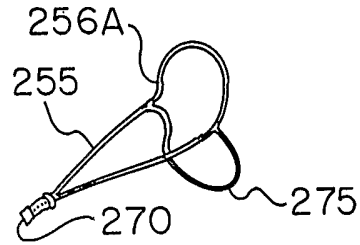

FIG. 2B

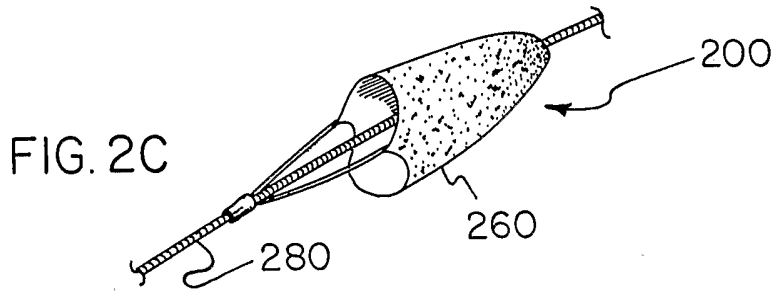

FIG. 2C

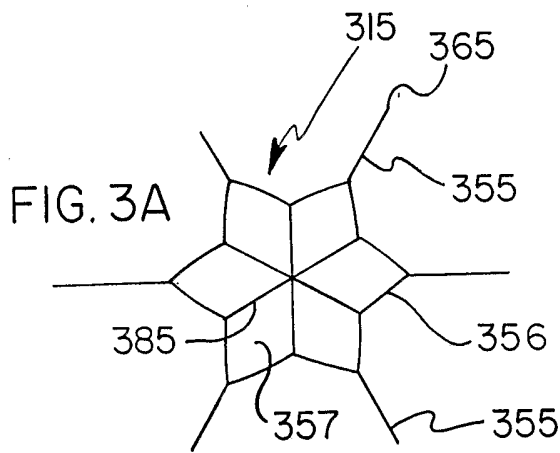

FIG. 3A

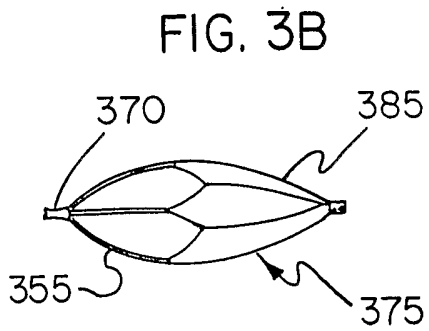

FIG. 3B

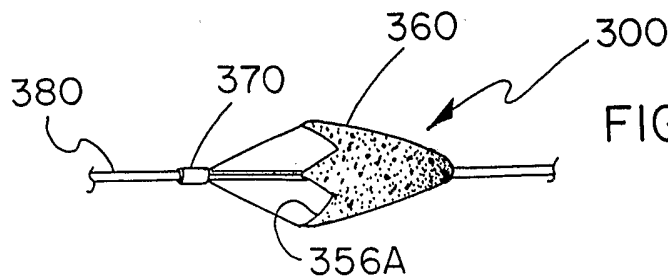
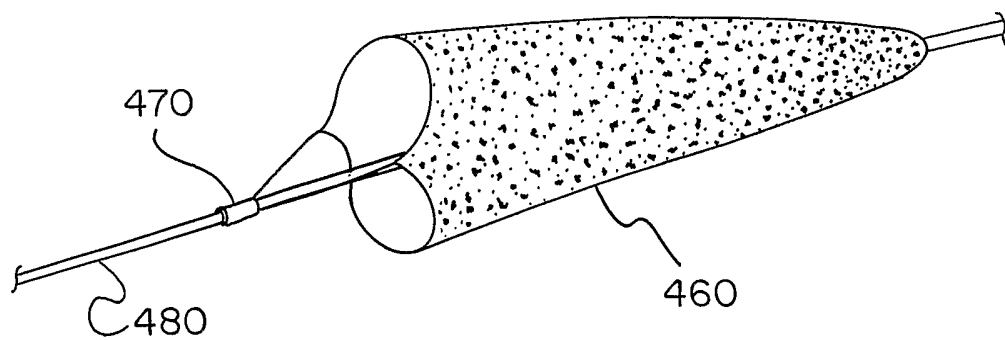
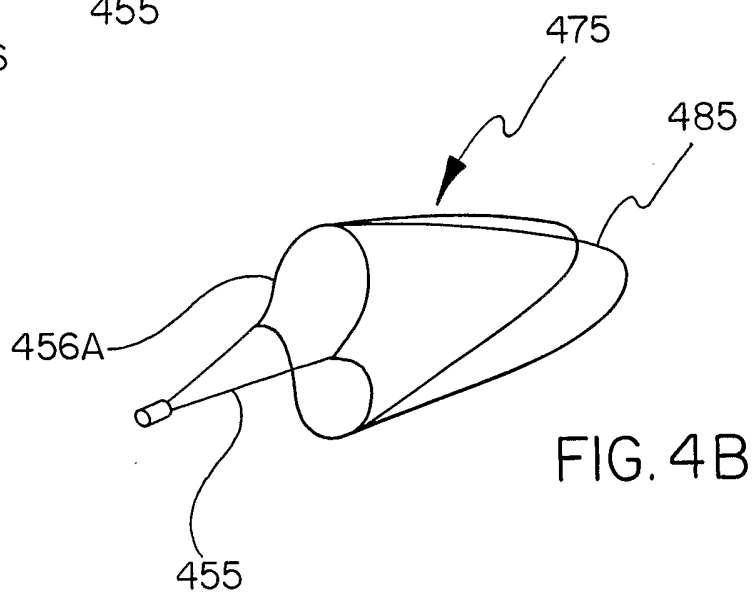
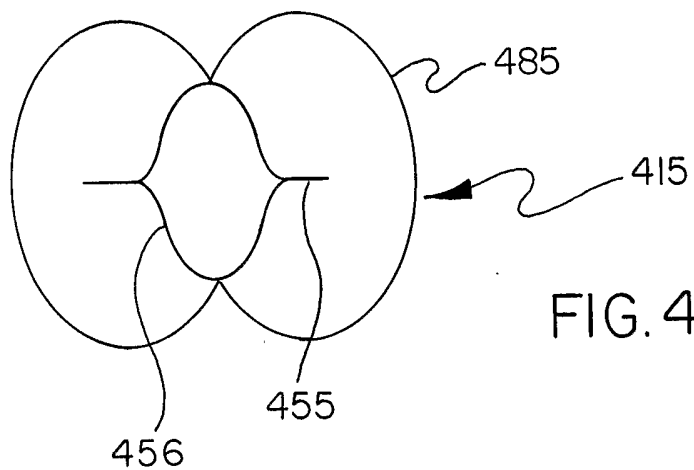
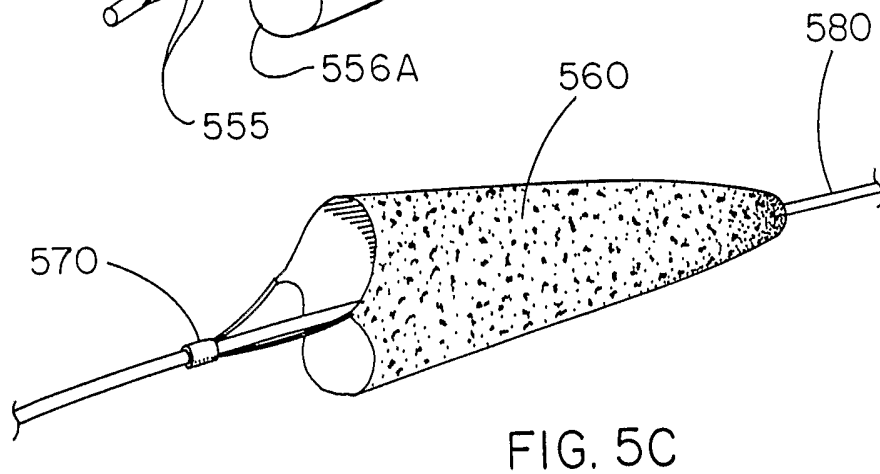
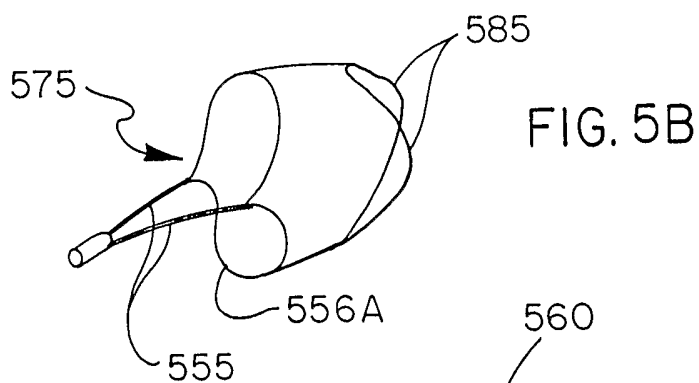
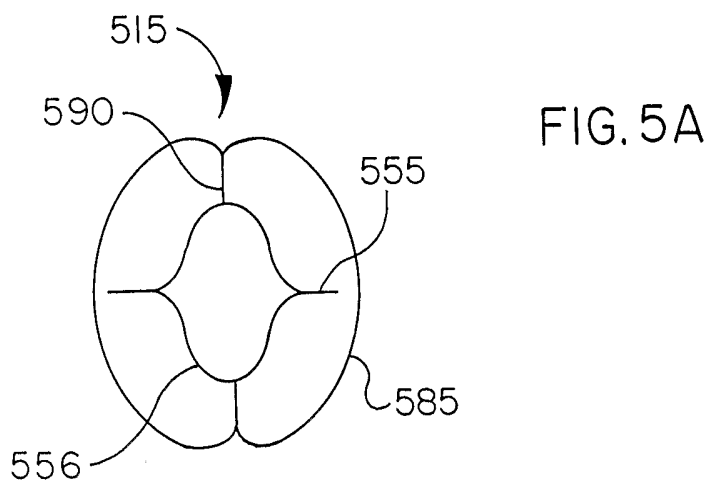

FIG. 3C





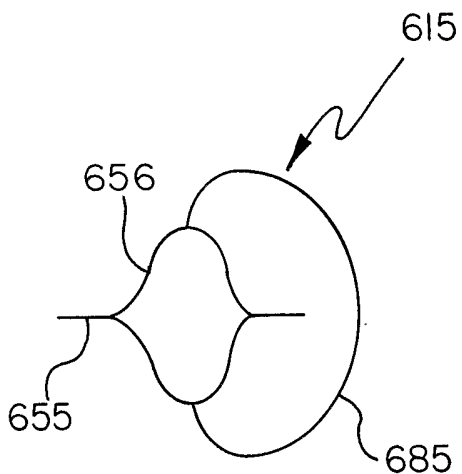

FIG. 6A

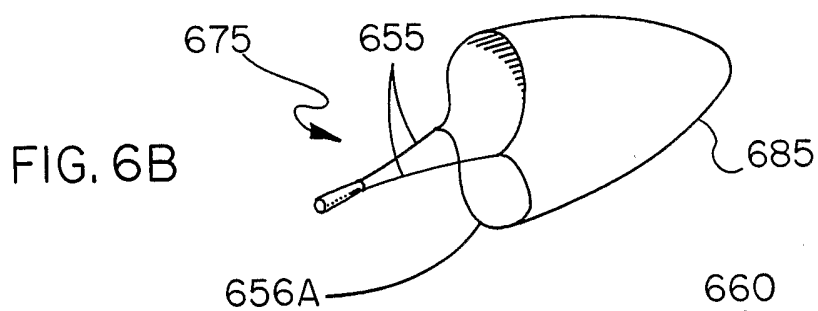

FIG. 6B

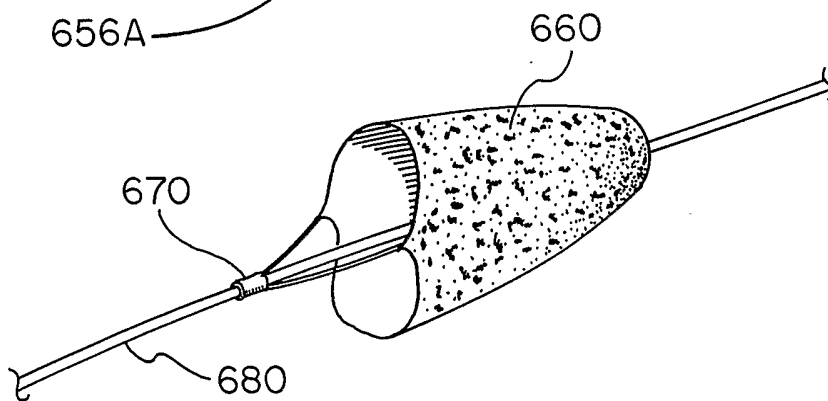

FIG. 6C

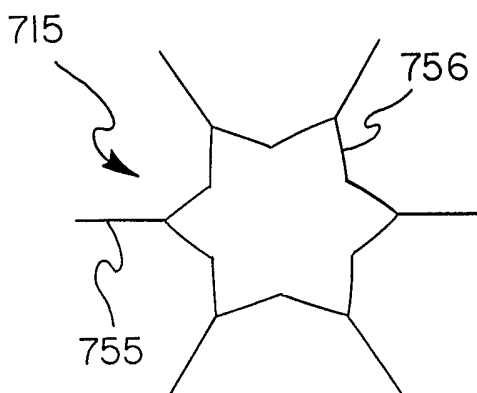

FIG. 7A

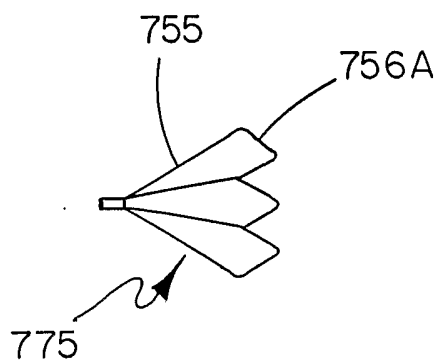

FIG. 7B

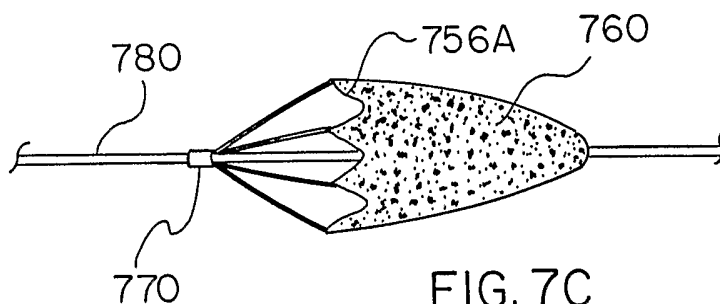

FIG. 7C

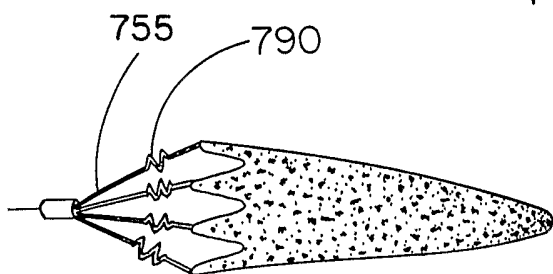

FIG. 7D

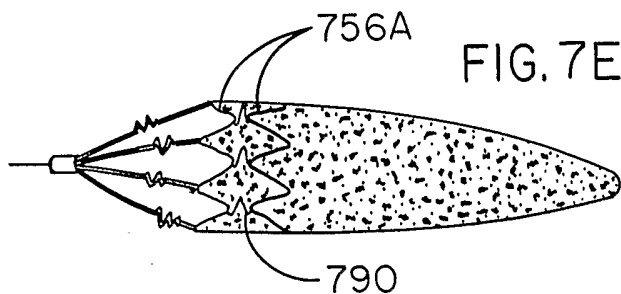

FIG. 7E

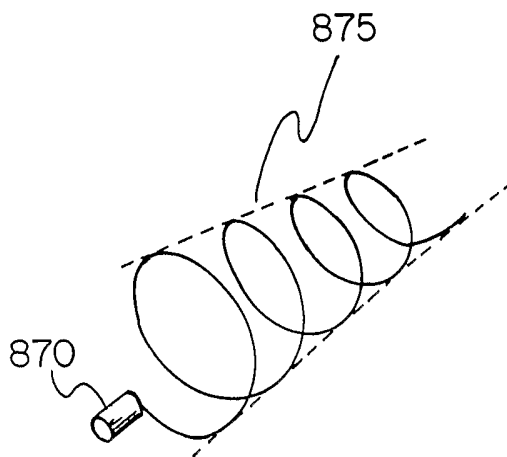
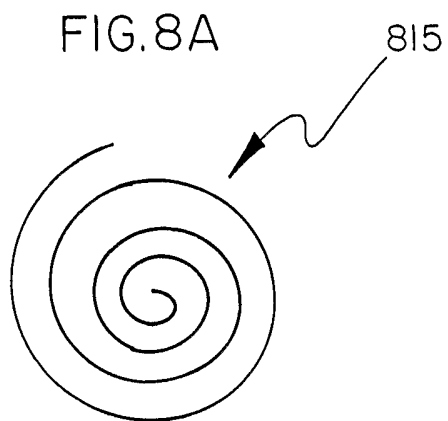

FIG. 8B

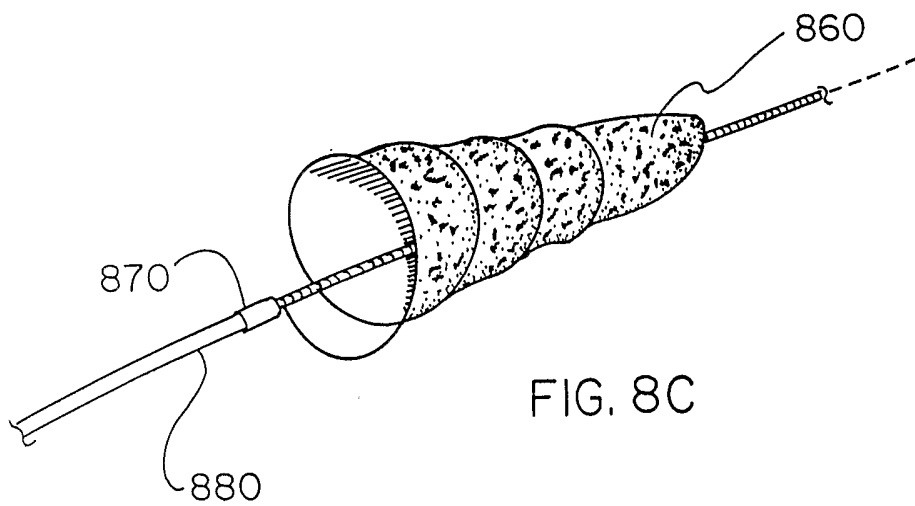

FIG. 8C

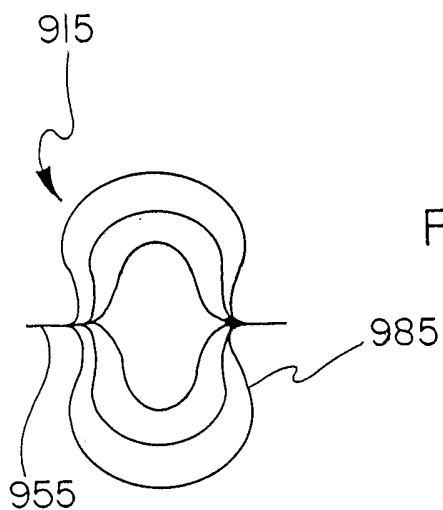

FIG. 9A

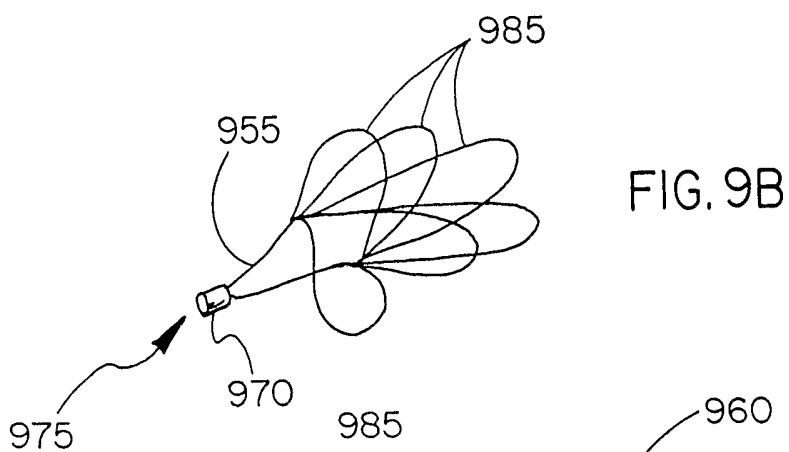

FIG. 9B

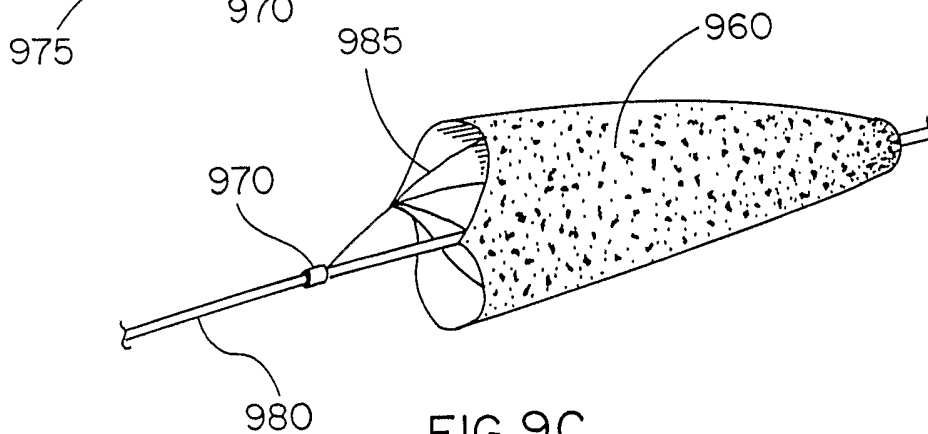
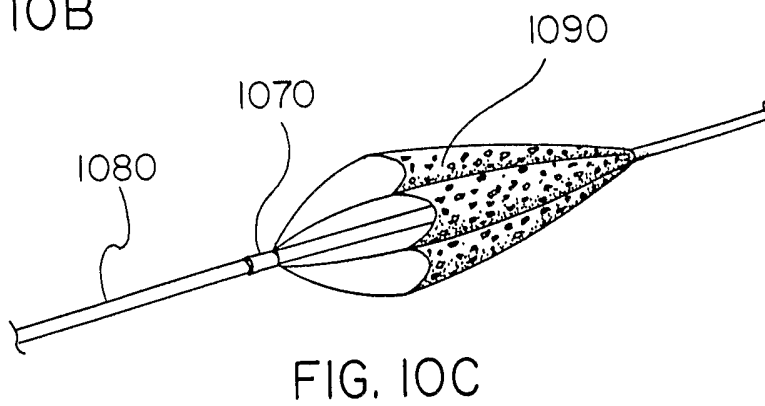
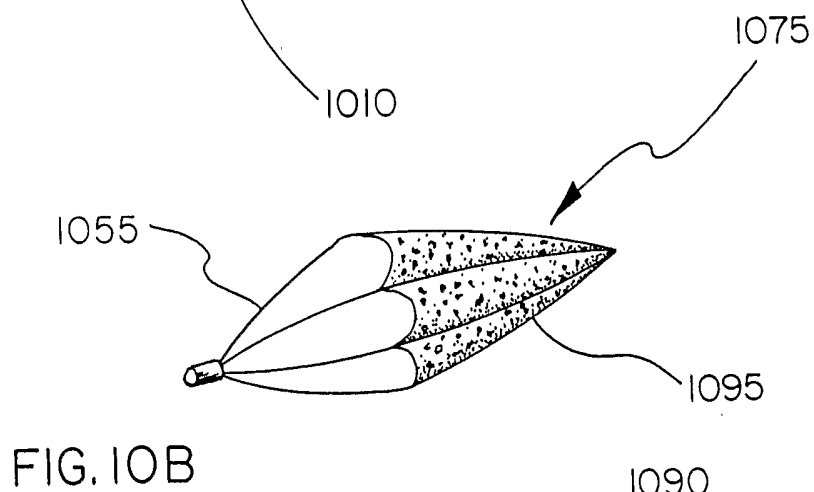
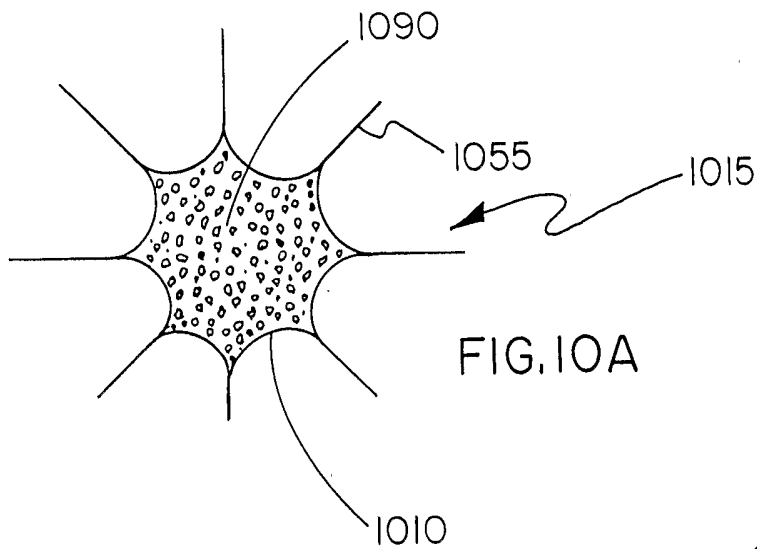

FIG. 9C



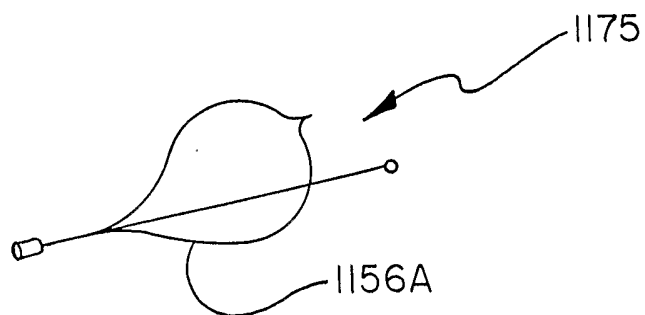
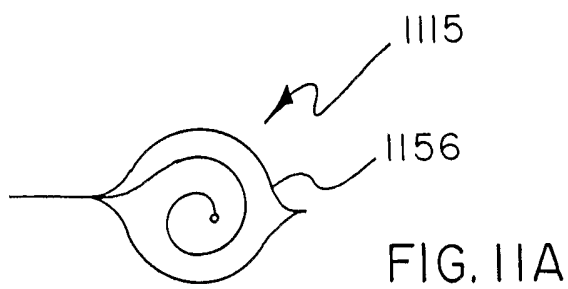

FIG. IIB

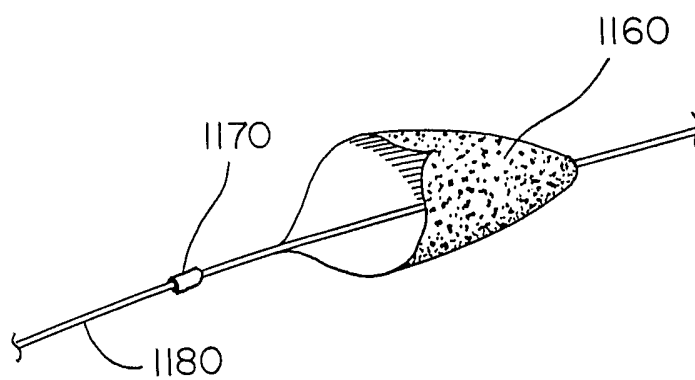

FIG. IIC

FIG. 12A

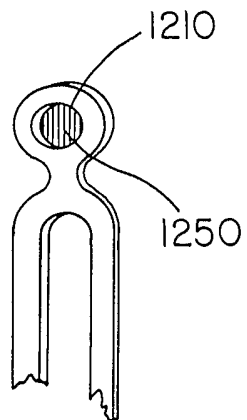

FIG. 12B

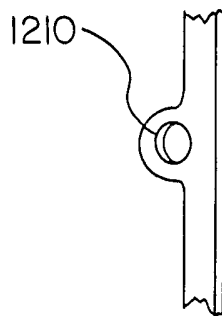

FIG. 12C

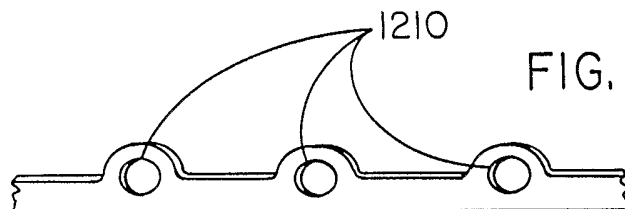
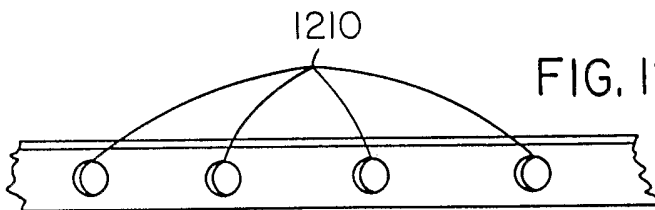

FIG. 12D



1210

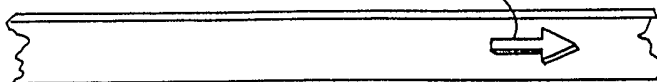

FIG. 12E

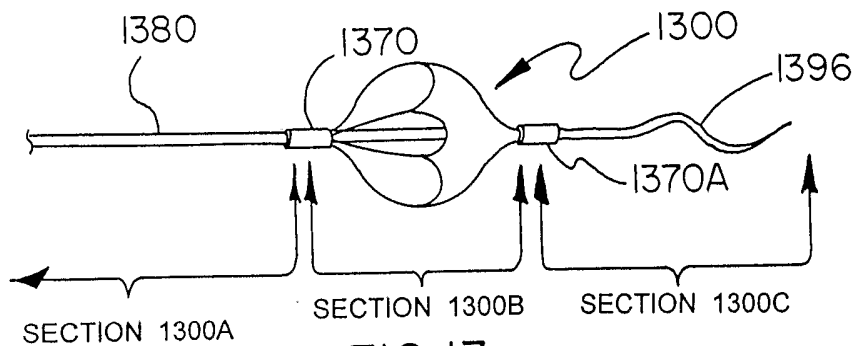

FIG. 13

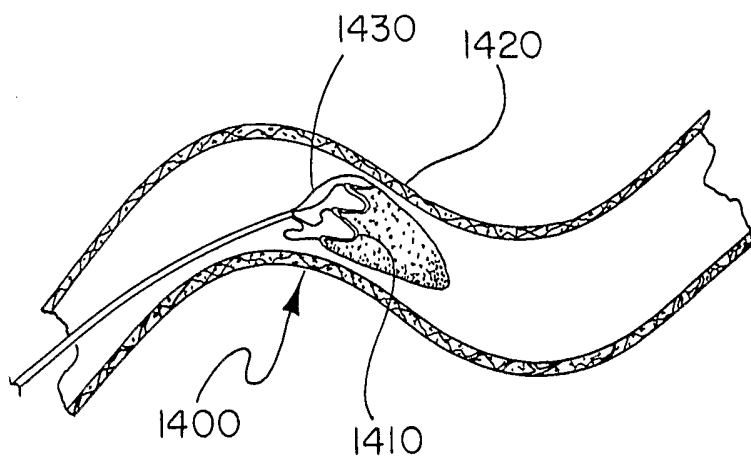

FIG. 14A

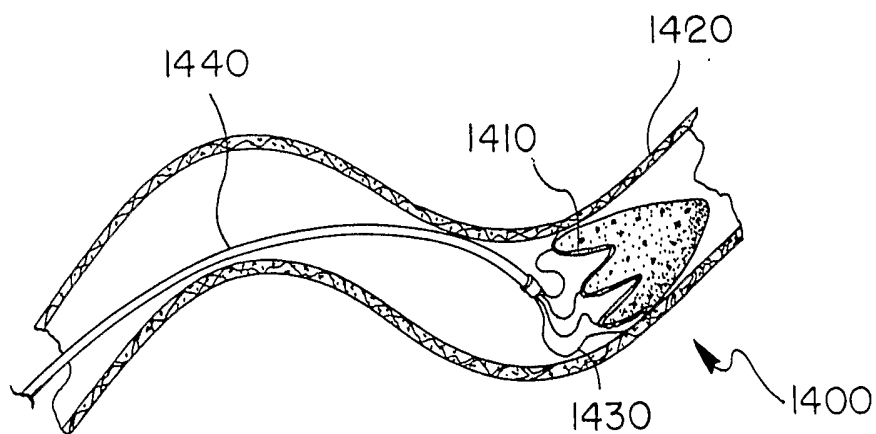

FIG. 14B

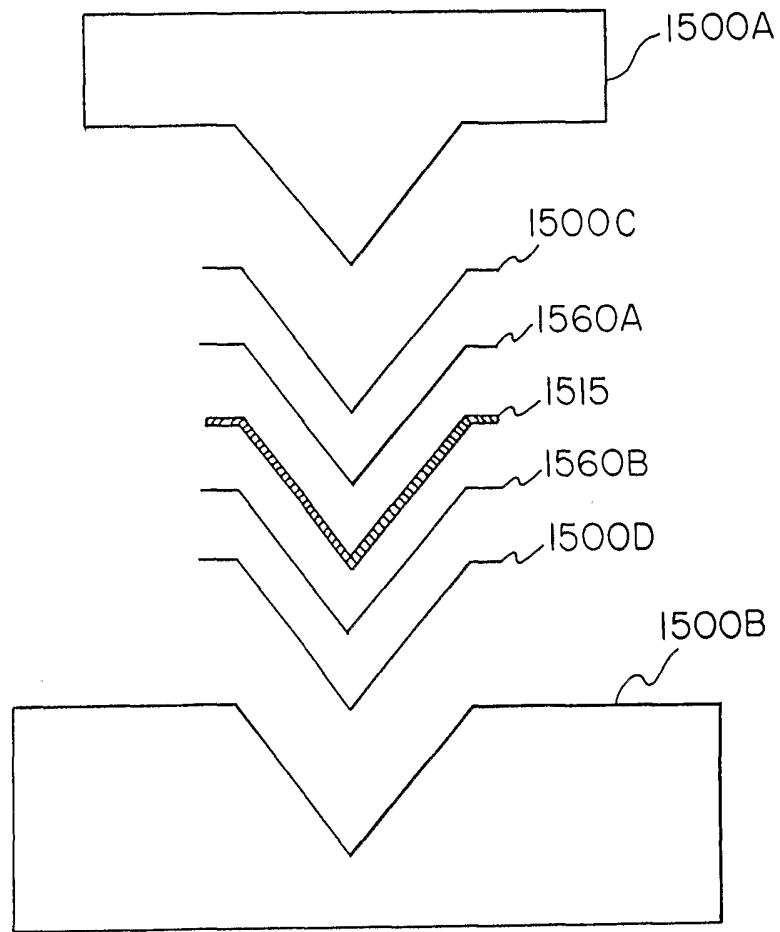
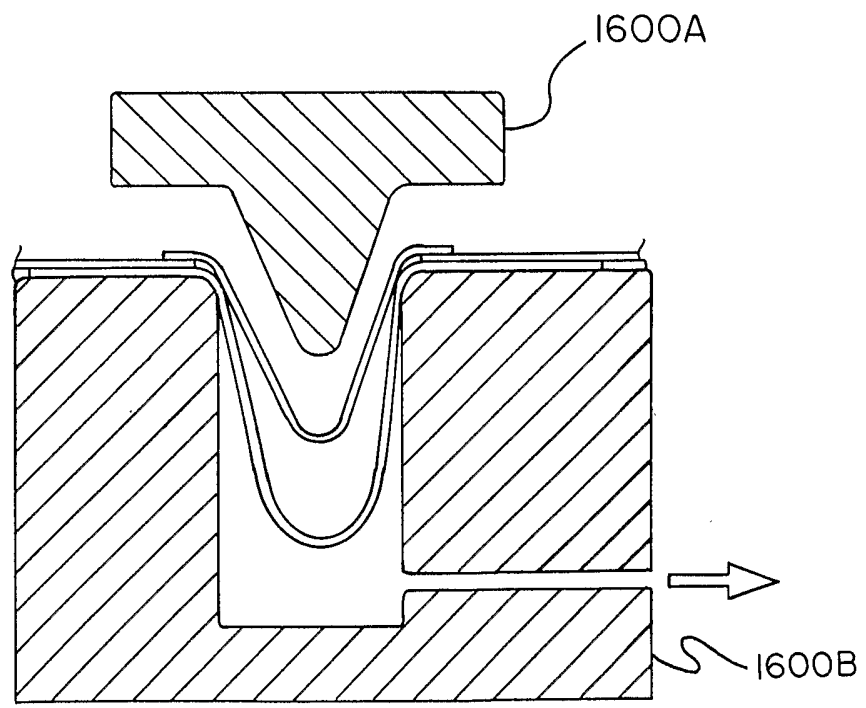
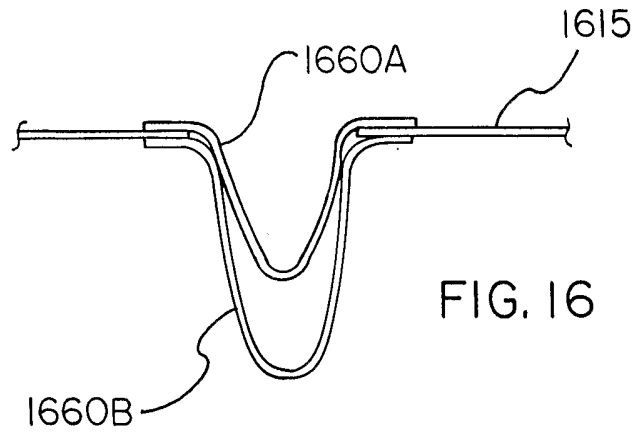

FIG. 15



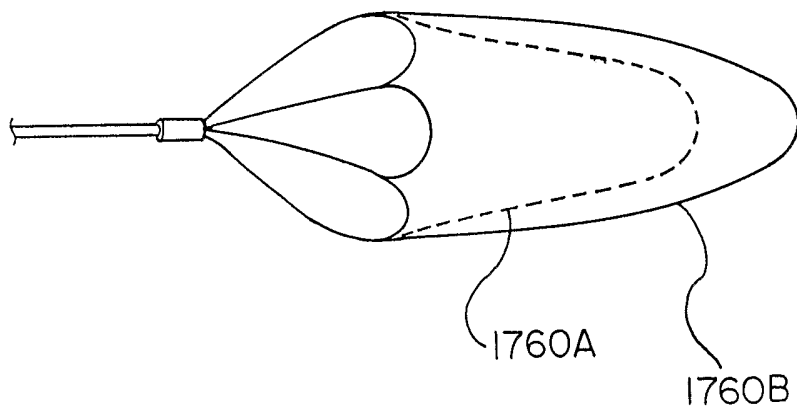
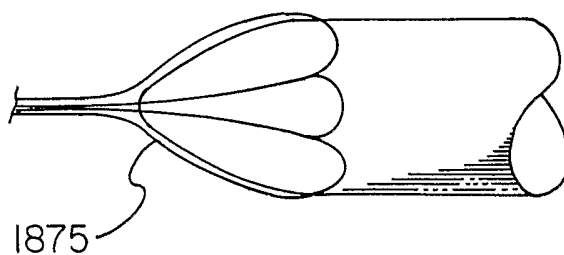
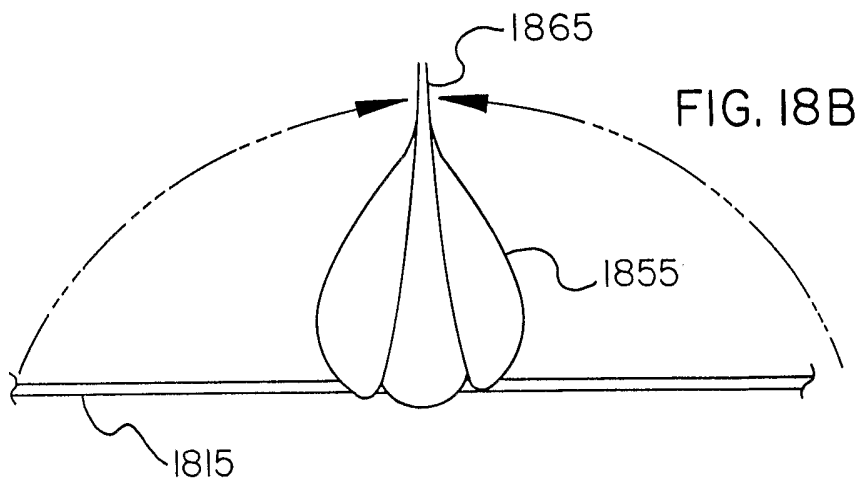
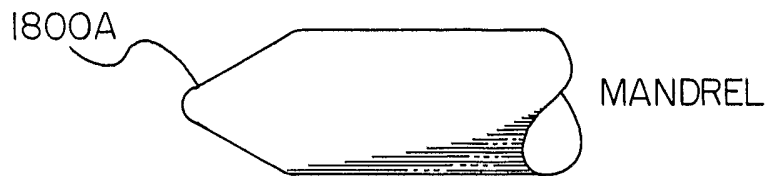

FIG. 17



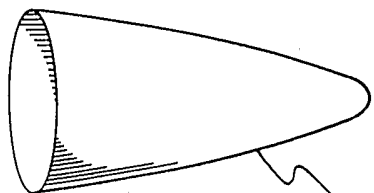

FIG. 19A

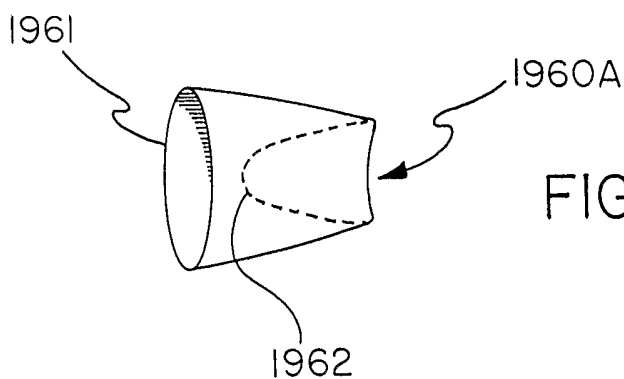

FIG. 19B

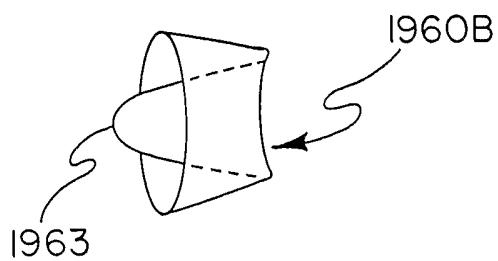

FIG. 19C

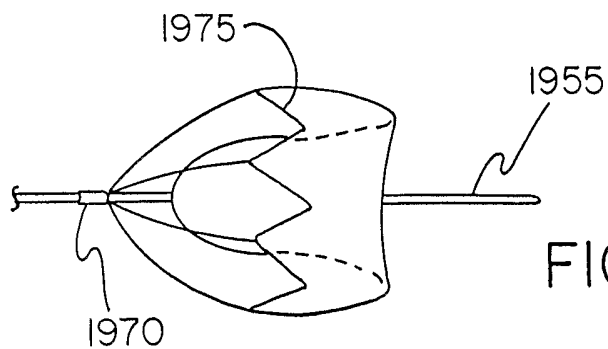

FIG. 19D

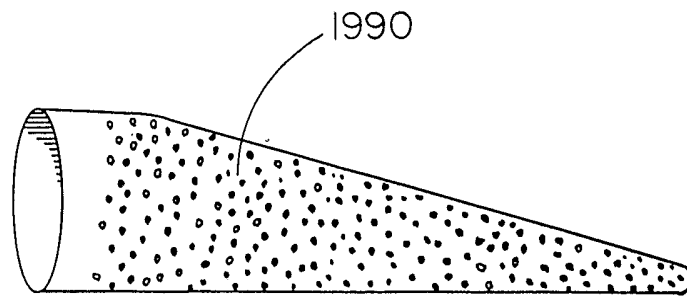

FIG. 19E

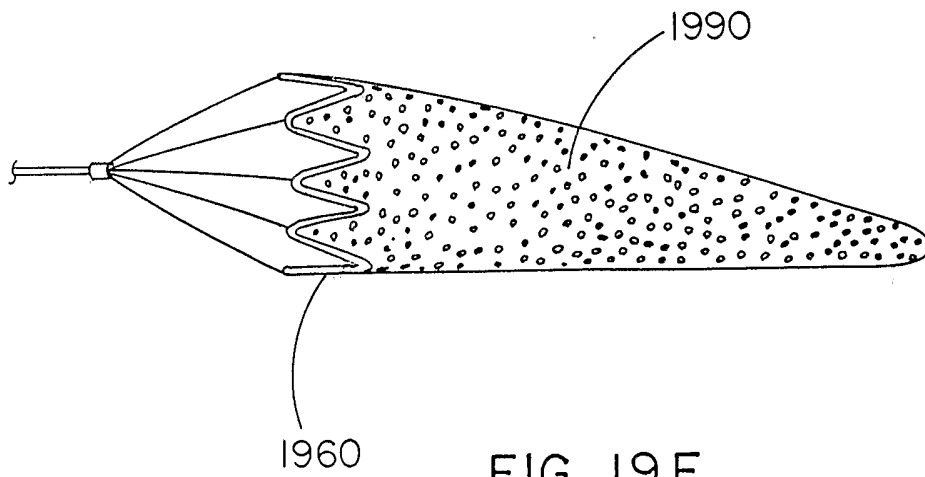

FIG. 19F

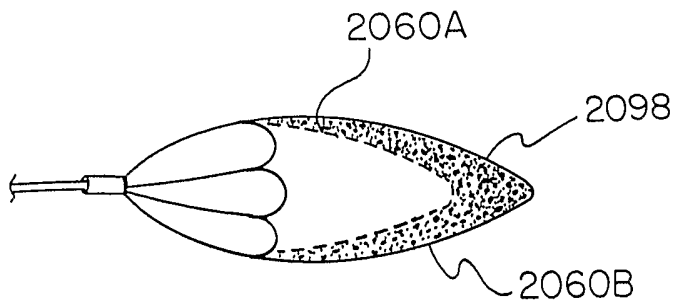

FIG. 20A

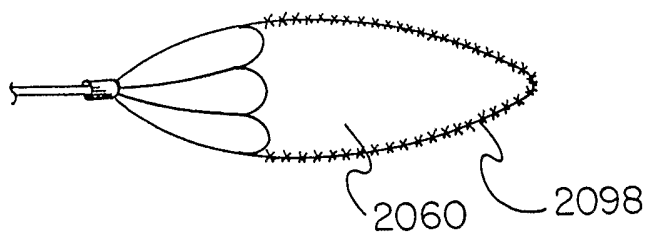

FIG. 20B

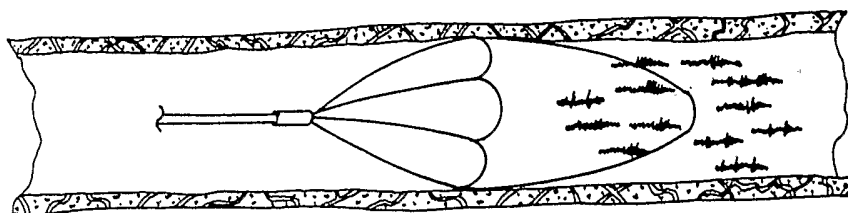

FIG. 20C

FIG. 21A

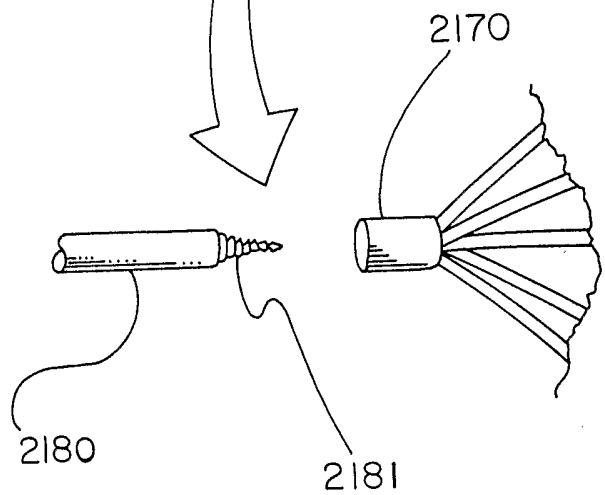
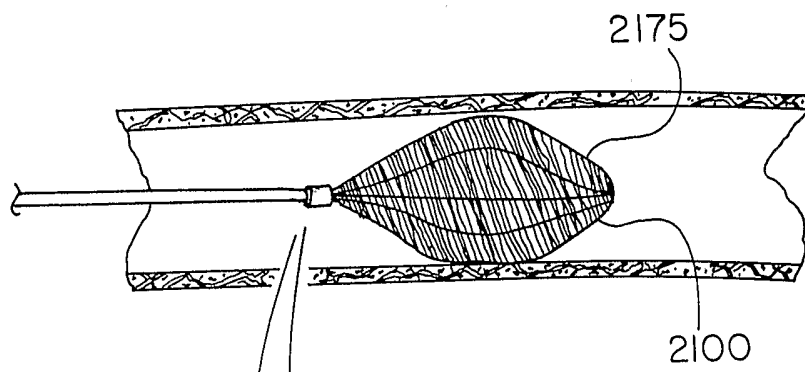

FIG. 21B

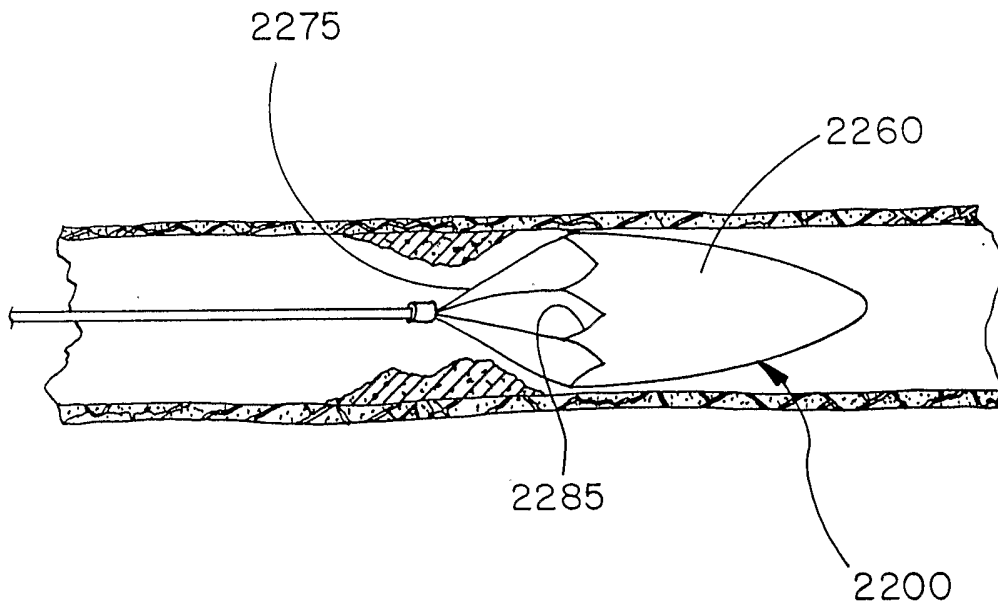

FIG. 22A

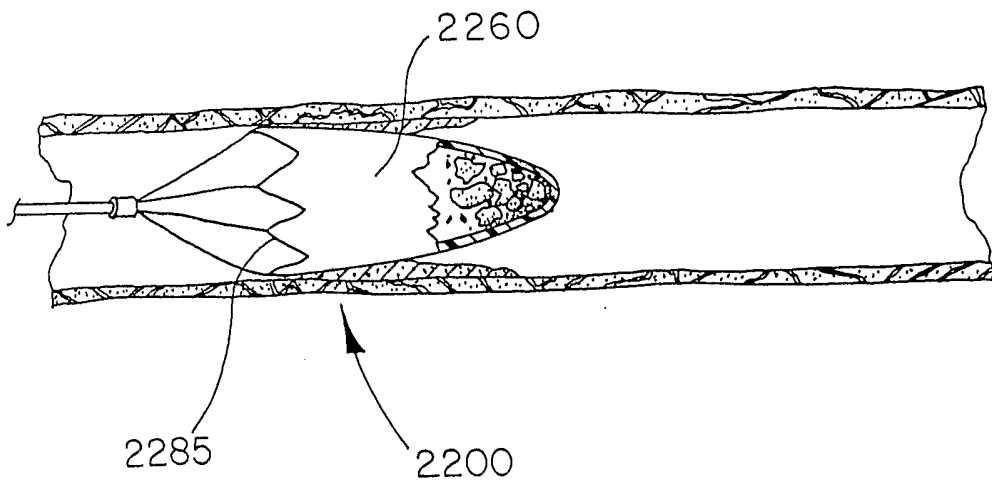
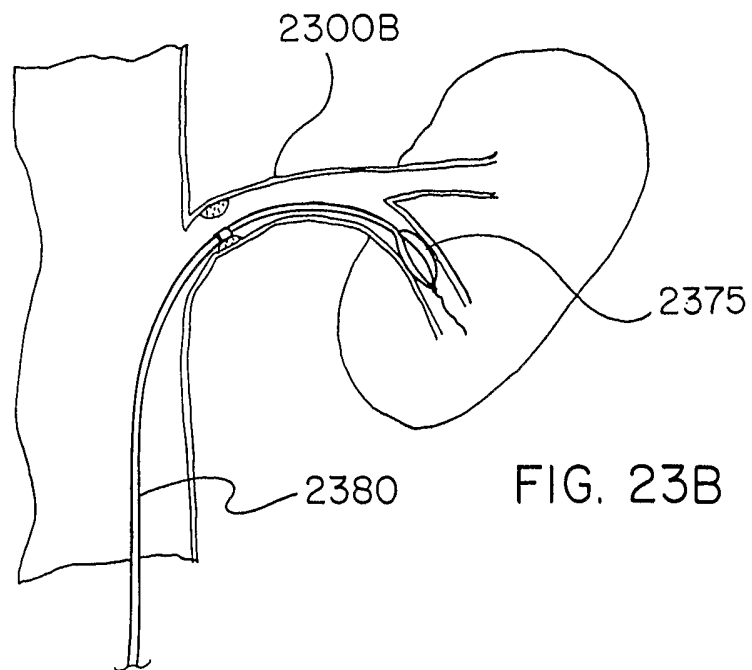
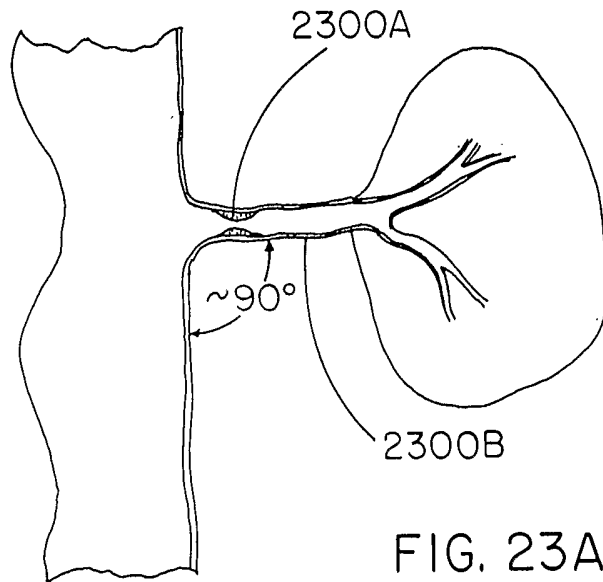

FIG. 22B



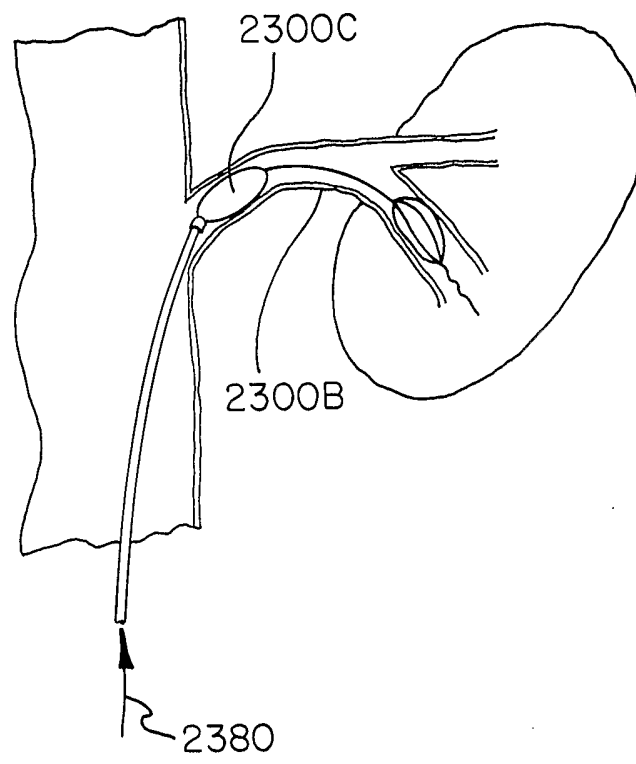
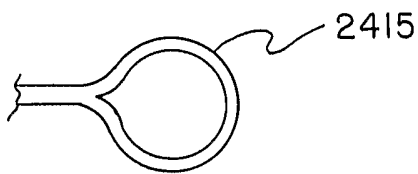

FIG. 23C

FIG. 24A



2475

FIG. 24B

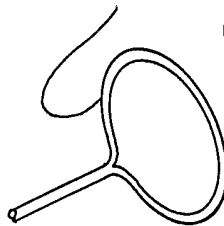

2476

FIG. 24C

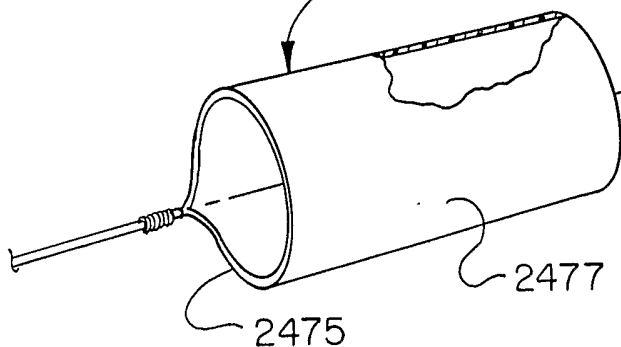

2400A

FIG. 24D

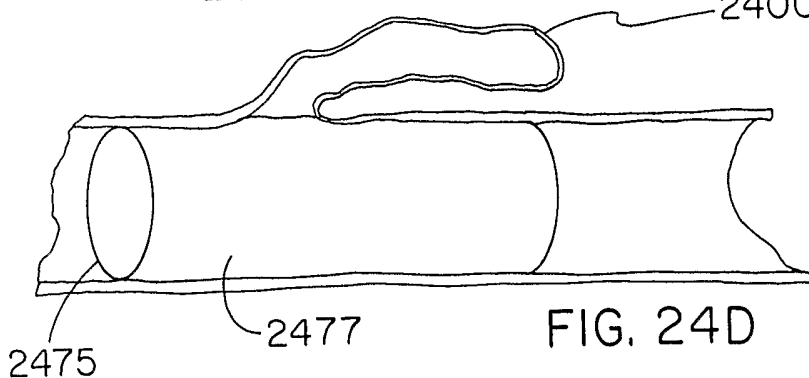
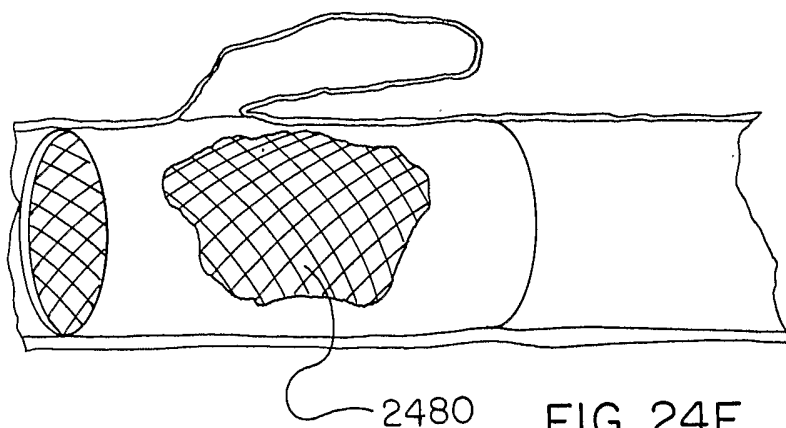

FIG. 24E



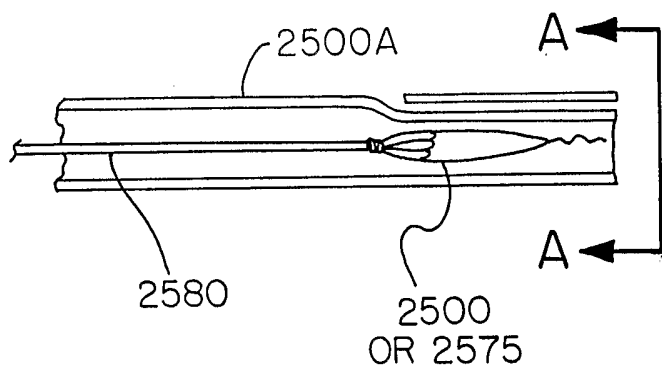

FIG. 25A

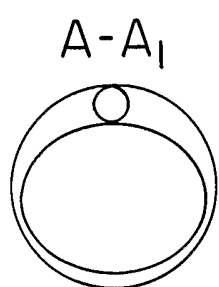

FIG. 25B

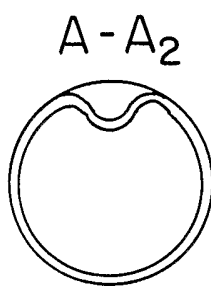

FIG. 25C

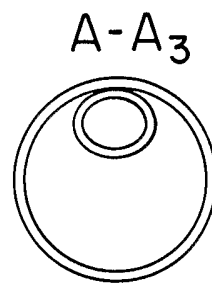

FIG. 25D

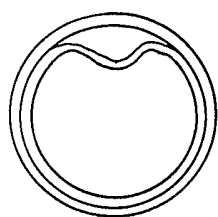

FIG. 25E

A₂-A₂

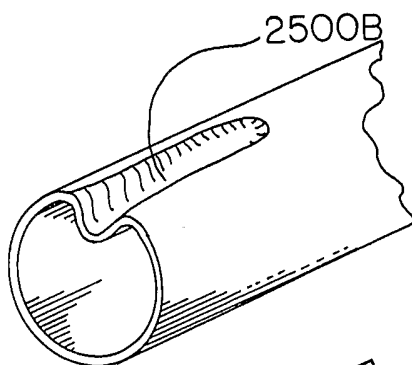

FIG. 25F

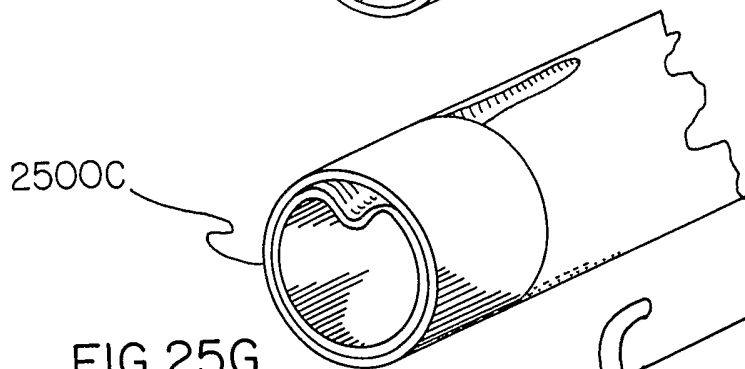

FIG. 25G

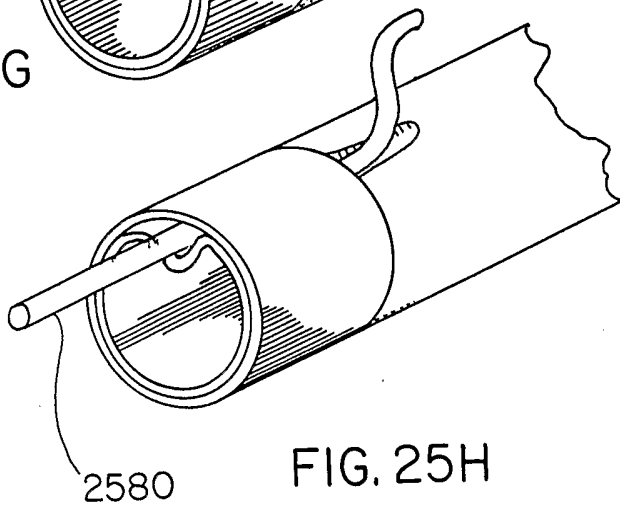

FIG. 25H

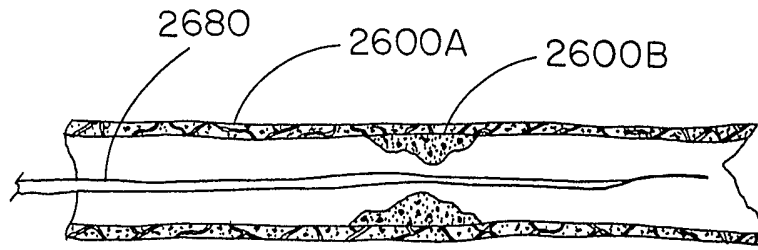

FIG. 26A

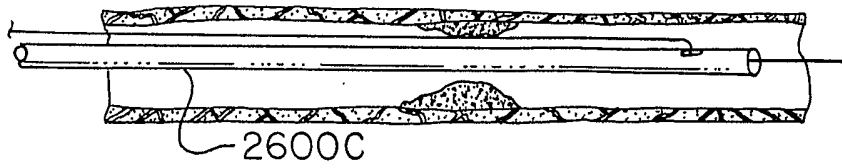

FIG. 26B

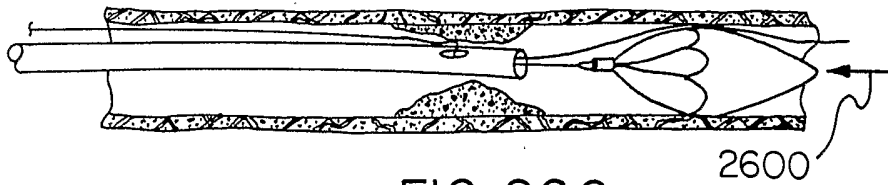

FIG. 26C

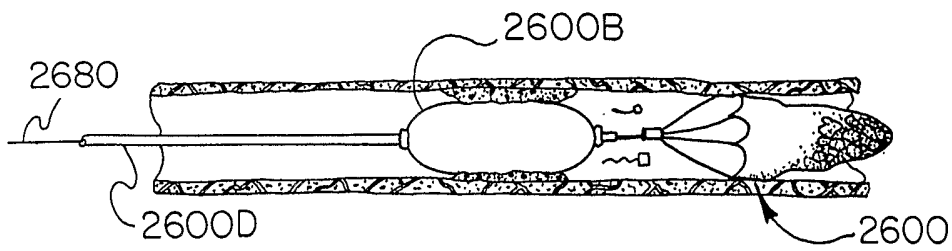

FIG. 26D

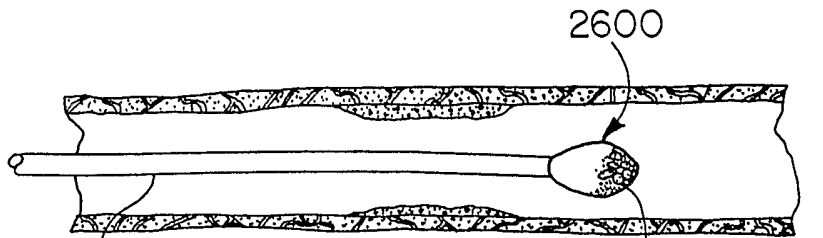

FIG. 26E

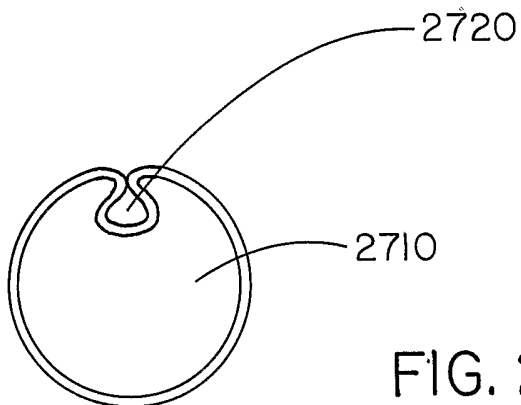

FIG. 27A

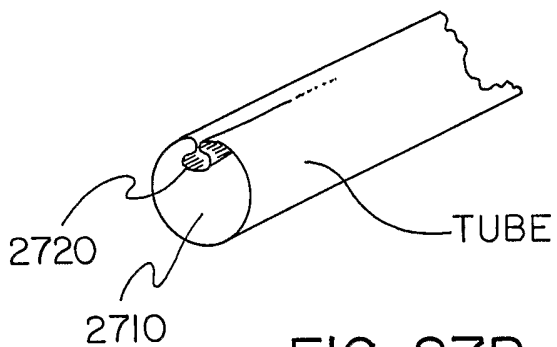

FIG. 27B

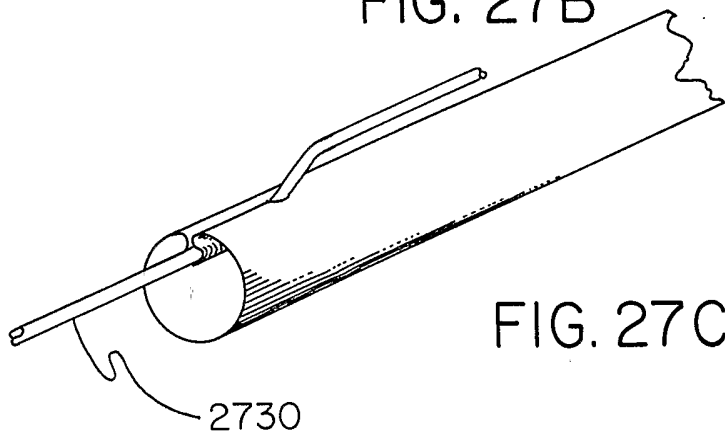

FIG. 27C

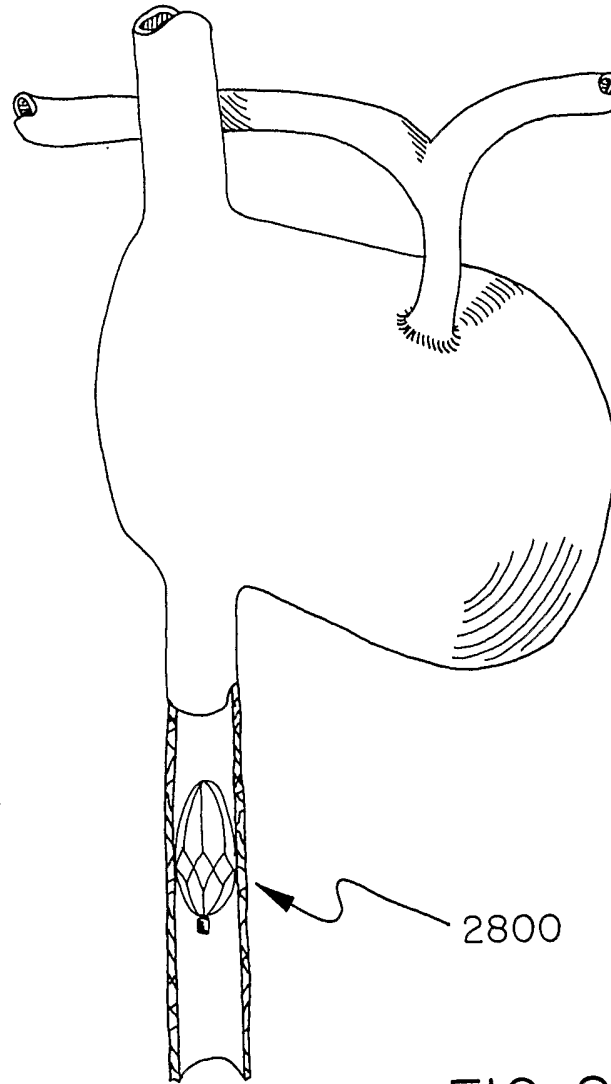

FIG. 28

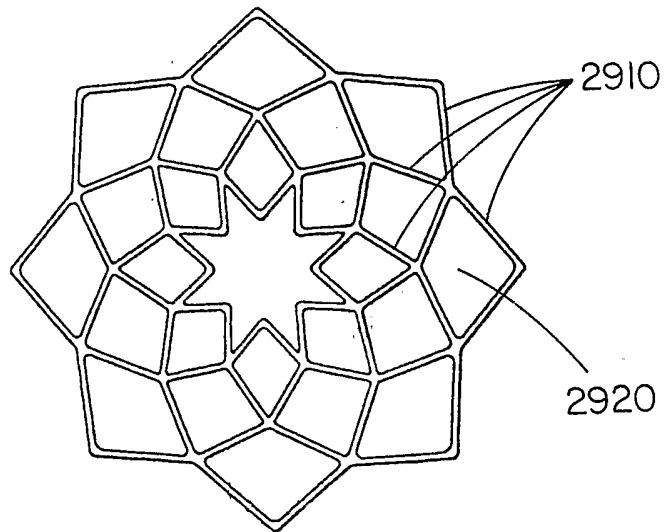

FIG. 29A

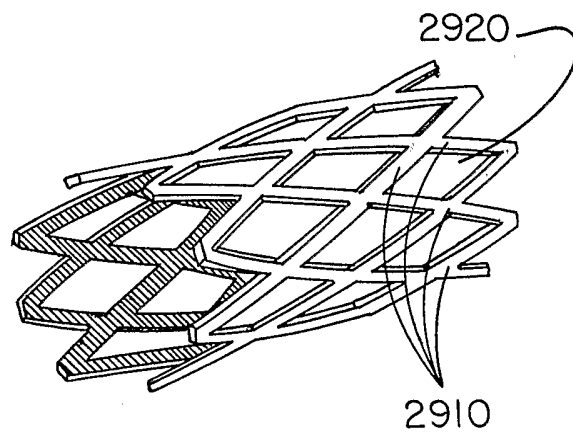

FIG. 29B

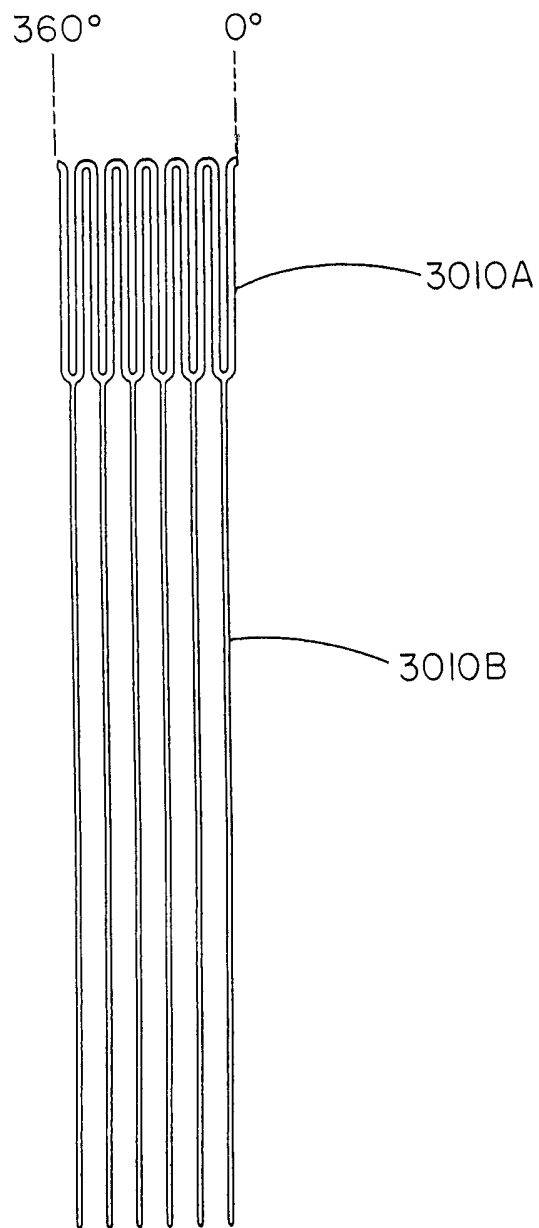

FIG. 30

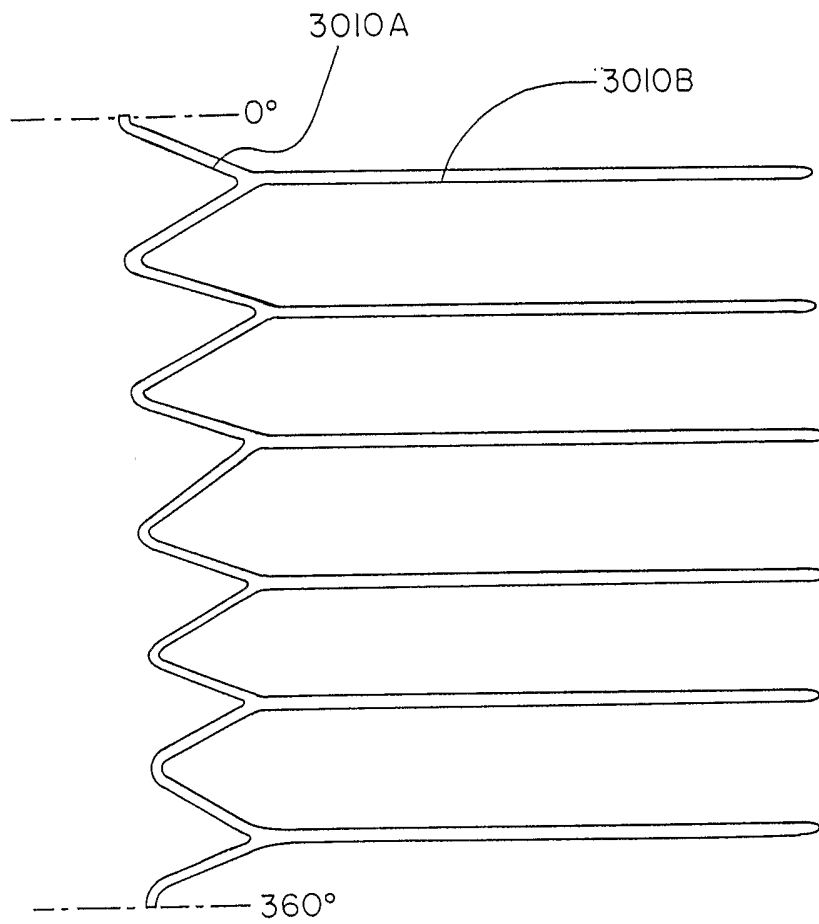
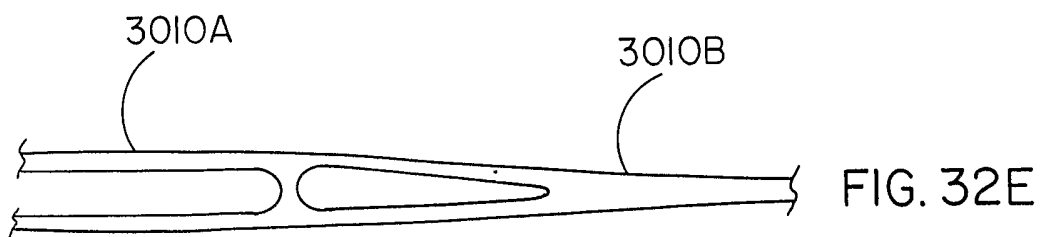
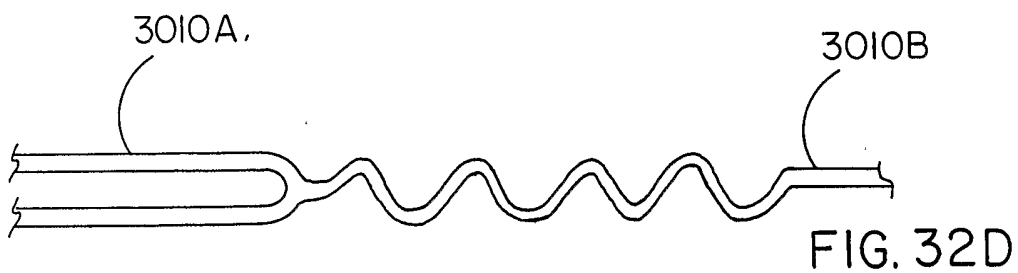
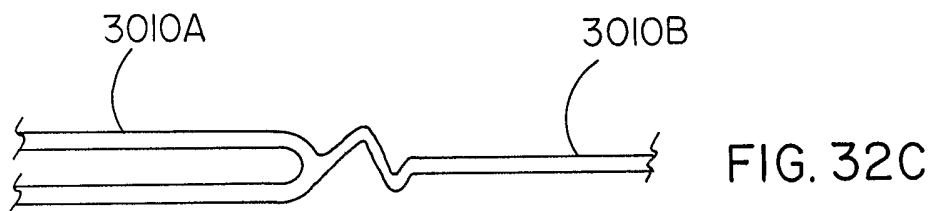
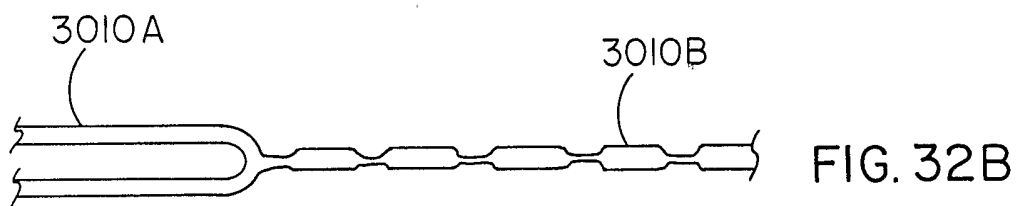
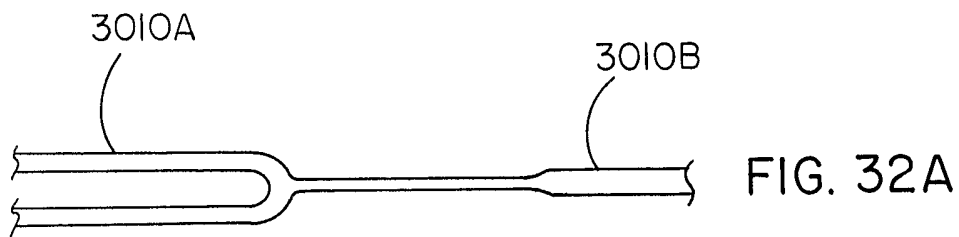

FIG. 31



PCT

DECLARATION OF NON-ESTABLISHMENT OF INTERNATIONAL SEARCH REPORT

(PCT Article 17(2)(a), Rules 13ter.1(c) and Rule 39)

Applicant's or agent's file reference MP/158	IMPORTANT DECLARATION	Date of mailing(<i>day/month/year</i>) 29/08/2003
International application No. PCT/US 03/07780	International filing date(<i>day/month/year</i>) 13/03/2003	(Earliest) Priority date(<i>day/month/year</i>) 01/04/2002
International Patent Classification (IPC) or both national classification and IPC		A61F2/01, A61F2/06
Applicant GORE ENTERPRISE HOLDINGS, INC.		

This International Searching Authority hereby declares, according to Article 17(2)(a), that **no international search report will be established** on the international application for the reasons indicated below

1. The subject matter of the international application relates to:
 - a. scientific theories.
 - b. mathematical theories
 - c. plant varieties.
 - d. animal varieties.
 - e. essentially biological processes for the production of plants and animals, other than microbiological processes and the products of such processes.
 - f. schemes, rules or methods of doing business.
 - g. schemes, rules or methods of performing purely mental acts.
 - h. schemes, rules or methods of playing games.
 - i. methods for treatment of the human body by surgery or therapy.
 - j. methods for treatment of the animal body by surgery or therapy.
 - k. diagnostic methods practised on the human or animal body.
 - l. mere presentations of information.
 - m. computer programs for which this International Searching Authority is not equipped to search prior art.
2. The failure of the following parts of the international application to comply with prescribed requirements prevents a meaningful search from being carried out:
 the description the claims the drawings
3. The failure of the nucleotide and/or amino acid sequence listing to comply with the standard provided for in Annex C of the Administrative Instructions prevents a meaningful search from being carried out:
 the written form has not been furnished or does not comply with the standard.
 the computer readable form has not been furnished or does not comply with the standard.
4. Further comments:

Name and mailing address of the International Searching Authority  European Patent Office, P.B. 5818 Patentlaan 2 NL-2280 HV Rijswijk Tel. (+31-70) 340-2040, Tx. 31 651 epo nl, Fax: (+31-70) 340-3016	Authorized officer Lucia Ertl
--	---

FURTHER INFORMATION CONTINUED FROM PCT/ISA/ 203

In view of the large number and also the wording of the claims presently on file, which render it difficult, if not impossible, to determine the matter for which protection is sought, the present application fails to comply with the clarity and conciseness requirements of Article 6 PCT (see also Rule 6.1(a) PCT) to such an extent that a meaningful search is impossible. Consequently, no search report can be established for the present application.

Particular defects are the following:

The ordering of the claims is unduly confusing. For example, claim 70 refers back to claim 5, although many other independent claims are arranged between claims 1 and 70. Thus, identification of the claimed invention becomes extremely difficult. Many further examples can be found, such as claims 23-25, 38 and so forth. Moreover, the wording of the claims is so broad, that the claims are not supported by the description (Article 6 PCT). For example, claim 44 reads on all manufacturing processes in which pressing and thermal annealing are involved.

The applicant's attention is drawn to the fact that claims relating to inventions in respect of which no international search report has been established need not be the subject of an international preliminary examination (Rule 66.1(e) PCT). The applicant is advised that the EPO policy when acting as an International Preliminary Examining Authority is normally not to carry out a preliminary examination on matter which has not been searched. This is the case irrespective of whether or not the claims are amended following receipt of the search report or during any Chapter II procedure. If the application proceeds into the regional phase before the EPO, the applicant is reminded that a search may be carried out during examination before the EPO (see EPO Guideline C-VI, 8.5), should the problems which led to the Article 17(2) declaration be overcome.