



US 20100297469A1

(19) **United States**

(12) **Patent Application Publication**

Aota et al.

(10) **Pub. No.: US 2010/0297469 A1**

(43) **Pub. Date: Nov. 25, 2010**

(54) **METHOD OF JOINING TWO MEMBERS BY FRICTION STIR WELDING**

(76) Inventors: **Kinya Aota**, Kudamatsu-Shi (JP);
Tsuyoshi Takenaka, Yamaguchi-Ken (JP); **Yasuo Ishimaru**, Kudamatsu-Shi (JP)

Correspondence Address:
ANTONELLI, TERRY, STOUT & KRAUS, LLP
1300 NORTH SEVENTEENTH STREET, SUITE 1800
ARLINGTON, VA 22209-3873 (US)

(21) Appl. No.: **12/805,385**

(22) Filed: **Jul. 28, 2010**

Related U.S. Application Data

(60) Continuation of application No. 11/453,147, filed on Jun. 15, 2006, which is a division of application No. 10/600,573, filed on Jun. 23, 2003, now Pat. No. 7,073,701, which is a division of application No. 08/820,231, filed on Mar. 18, 1997, now Pat. No. 6,581,819.

(30) **Foreign Application Priority Data**

Mar. 19, 1996 (JP) 8-62491

Publication Classification

(51) **Int. Cl.**
B32B 15/01 (2006.01)

(52) **U.S. Cl.** **428/615**

(57) **ABSTRACT**

This invention provides a configuration of a joint that allows a satisfactory welded joint to be formed with reduced deformation of the joint region when two-face structures (panels) are friction-welded end to end. The panels **31**, **32** each have two substantially parallel plates **33**, **34** and a third member **35** connecting the two plates **33**, **34**. The end portions of the plates **33**, **34** of one panel **32** are friction-welded to the end portions of the plates **33**, **34** of the other panel **32**. At least one of the panels has a plate **36** at its end for connecting the plates **33** and **34** and has a rigidity to support a pressing force produced during the friction welding.

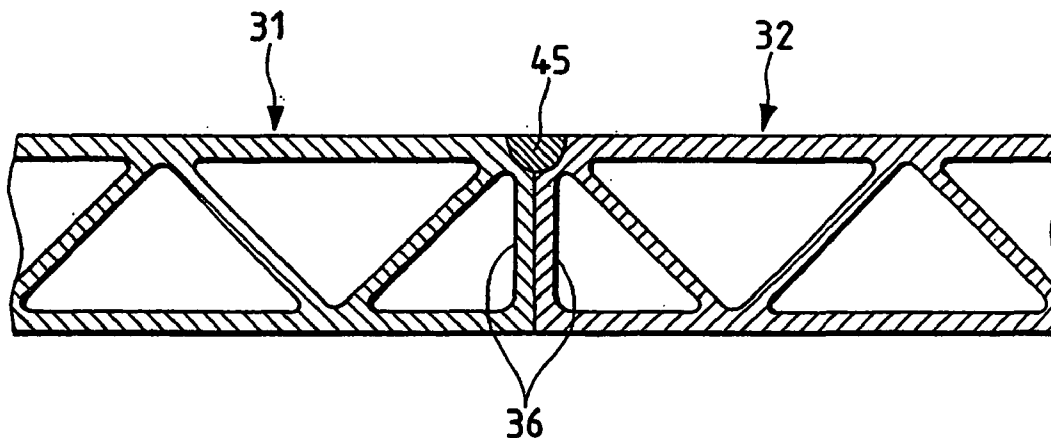

FIG. 1

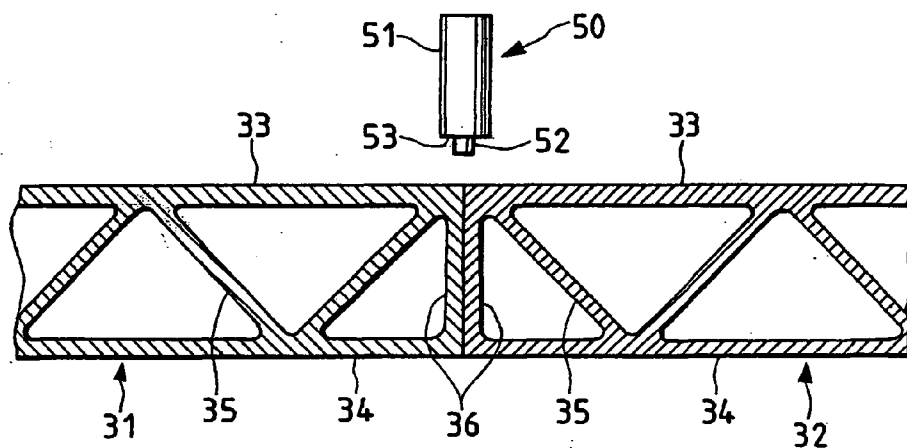

FIG. 2

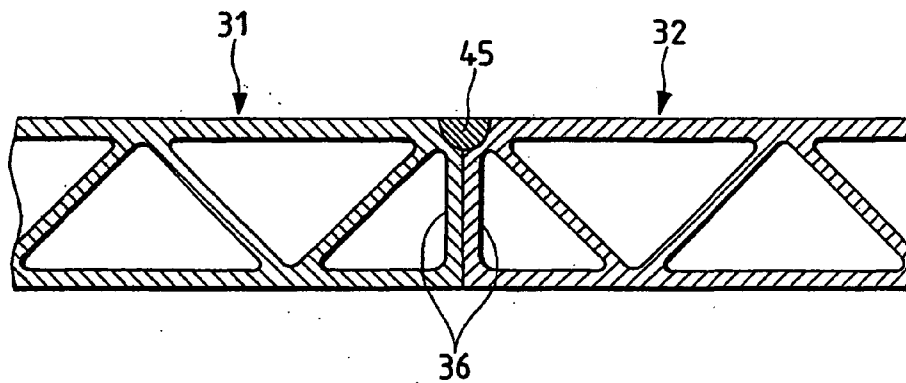

FIG. 3

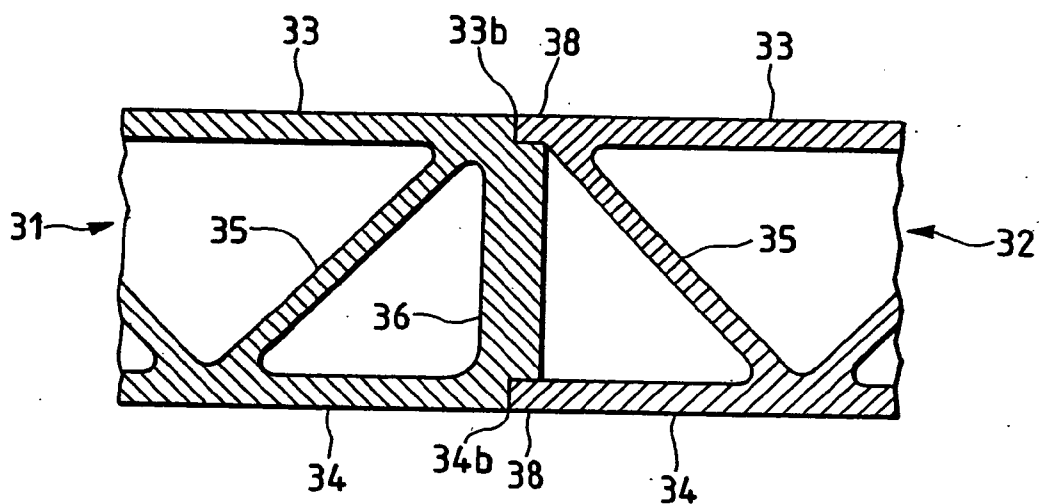

FIG. 4

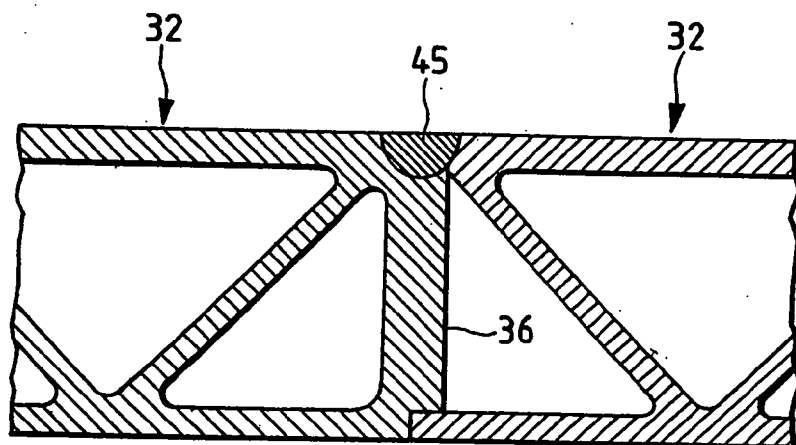

FIG. 5

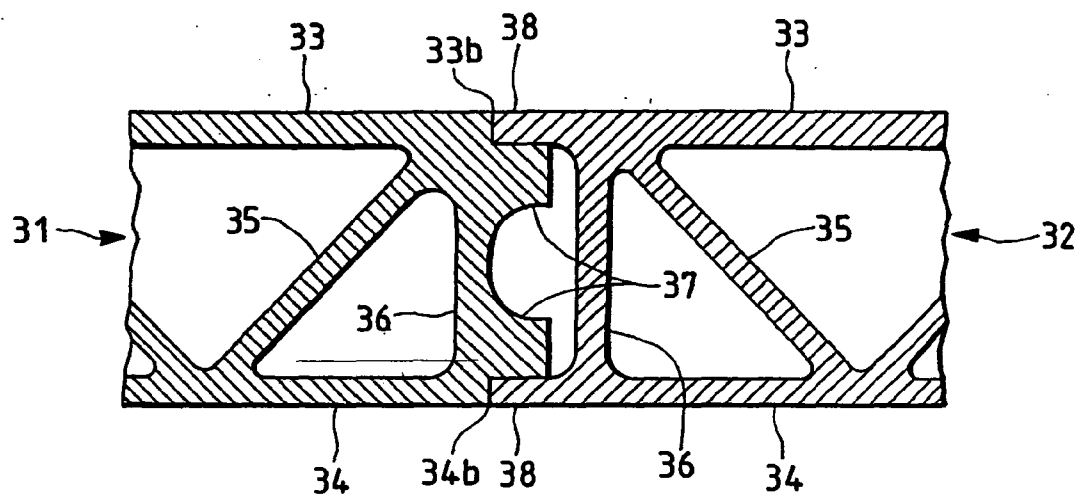

FIG. 6

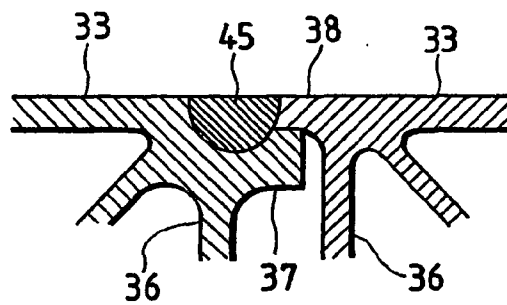

FIG. 7

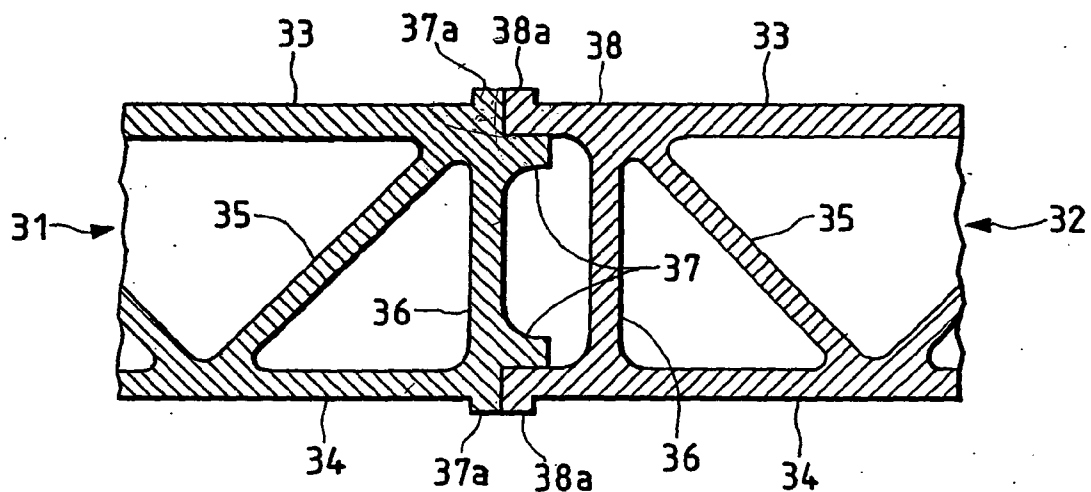
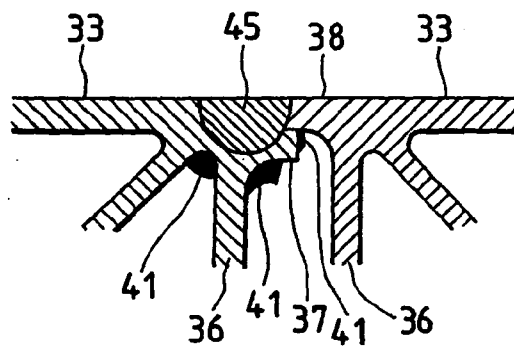

FIG. 8



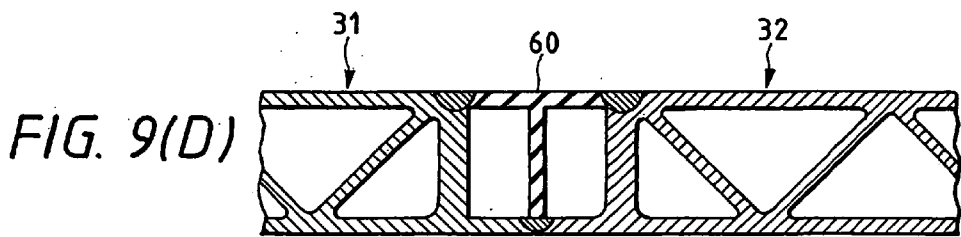
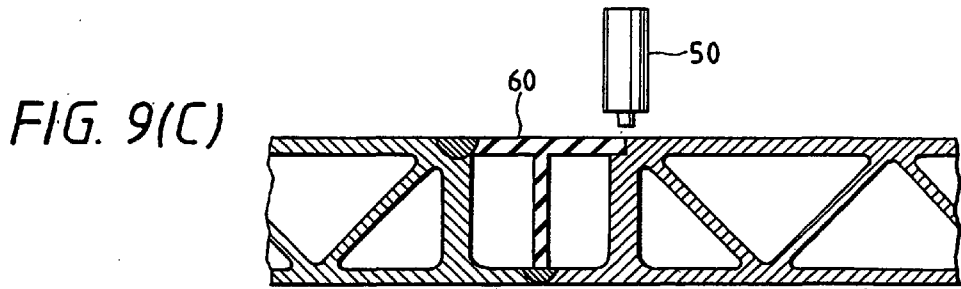
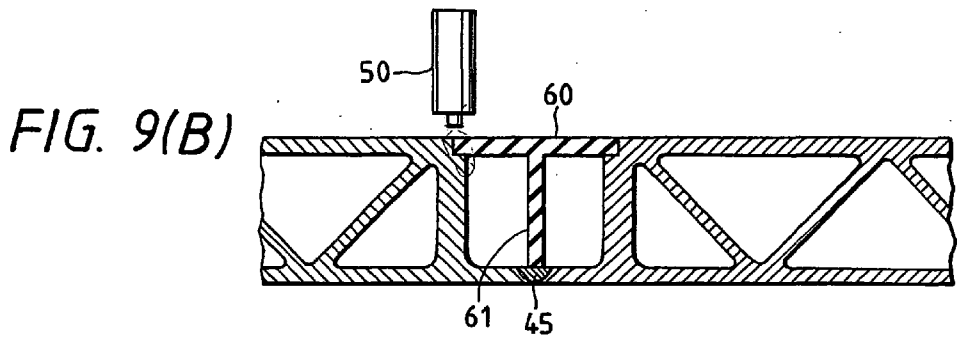
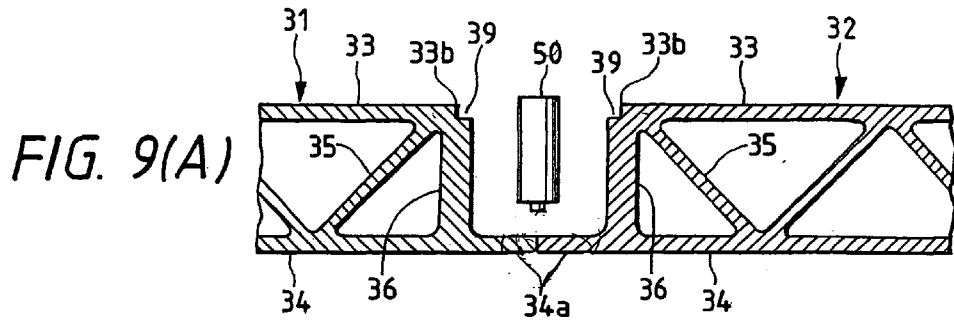

FIG. 10

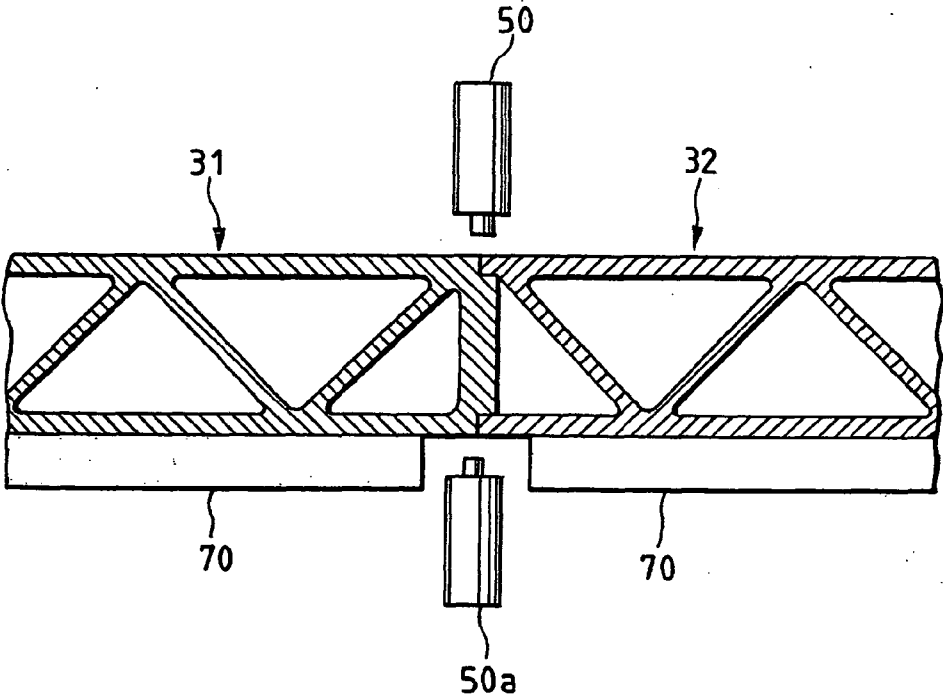

FIG. 11

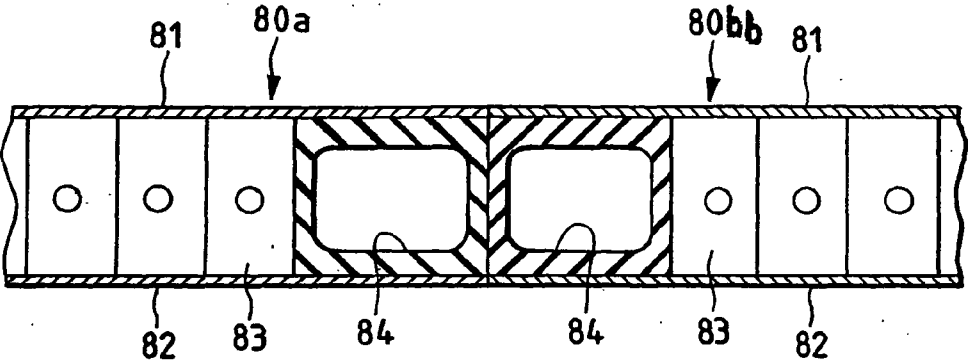

FIG. 12

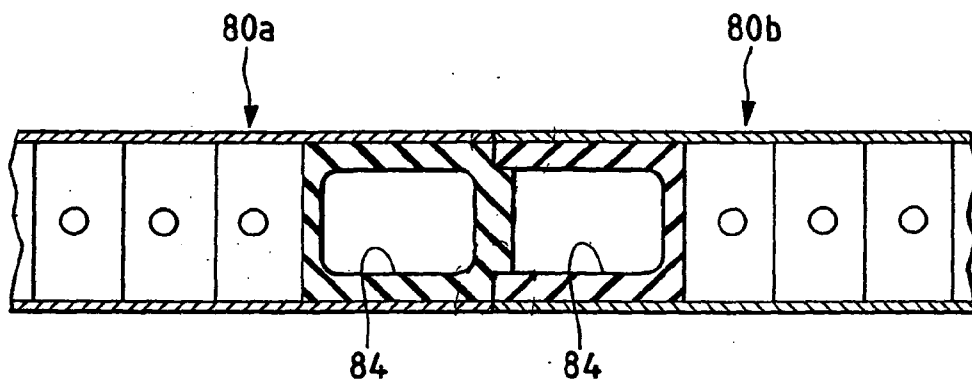

FIG. 13

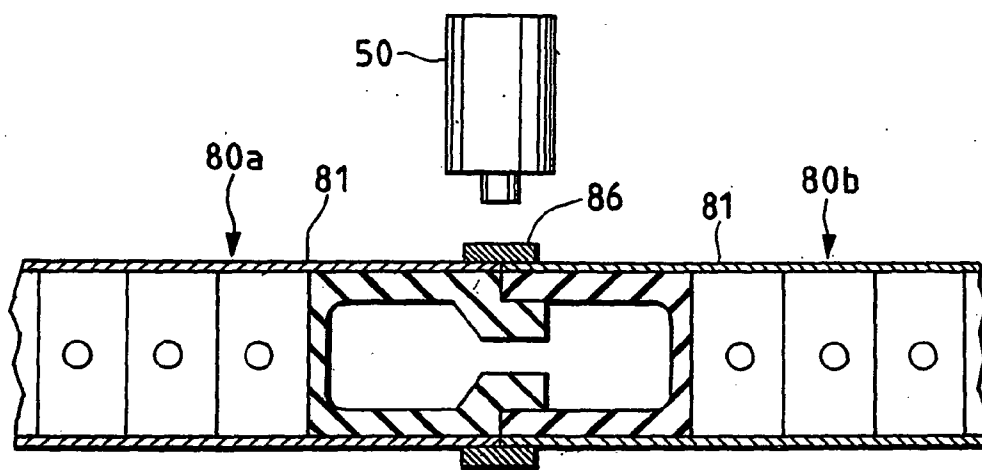

FIG. 14

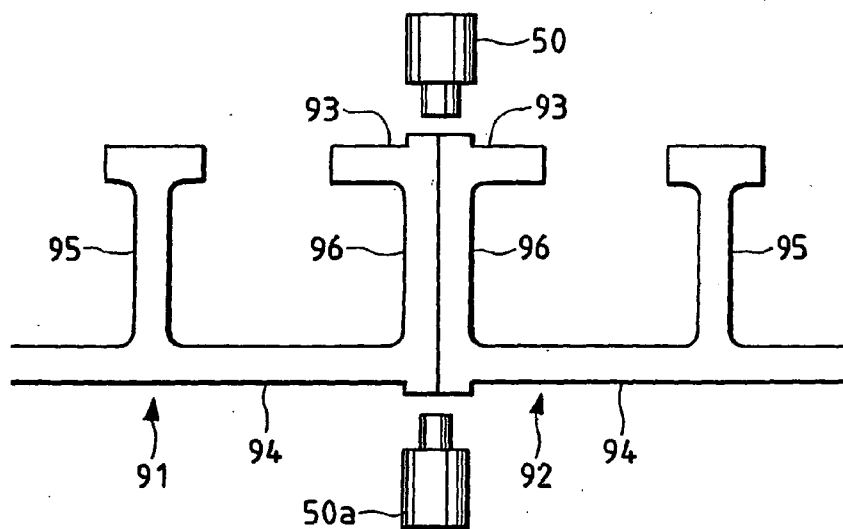
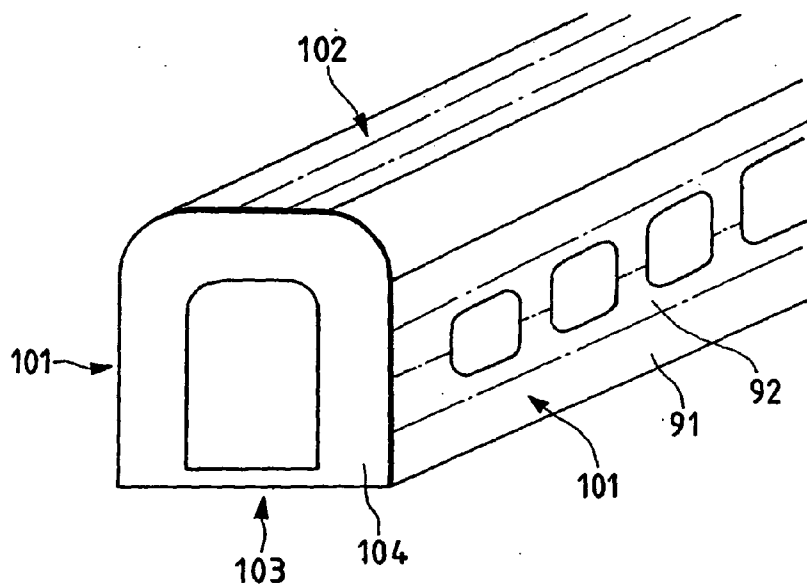

FIG. 15



METHOD OF JOINING TWO MEMBERS BY FRICTION STIR WELDING

[0001] This application is a Continuation application of application Ser. No. 11/453,147, filed Jun. 15, 2006, which is a Divisional application of application Ser. No. 10/600,573, filed Jun. 23, 2003, which is a Divisional application of application Ser. No. 08/820,231, filed Mar. 18, 1997, the contents of which are incorporated herein by reference in their entirety.

BACKGROUND OF THE INVENTION

[0002] The present invention relates to a friction stir welding method that is applicable to panel welding used, for example, in aluminum alloy railway cars and buildings.

[0003] A two-face structure (panel) for railway cars using hollow members is disclosed in Japanese Patent Laid-Open No. 246863/1990, and another using laminated panels, such as honeycomb panels, is disclosed in Japanese Patent Laid-Open No. 106661/1994.

[0004] The process of friction stir welding is performed by rotating a round rod inserted in a joint region to heat and plasticize the joint region thus forming a weld. This type of welding is generally applied to a butt joint and a lap joint, and is described in WO 93/10935 (which is the same as EP 061 5480B1 and the Japanese Announcement laid-open publication No. Hei 7-505090 and in the publication Welding & Metal Fabrication, January 1995, pp. 13-16.

SUMMARY OF THE INVENTION

[0005] In friction stir welding, the reaction of the plasticized metal being extruded from immediately beneath the rotating tool (round rod) to the surface during the welding results in a downward force acting on the joint region. Thus, when this welding method is applied to a two-face structure (panel), this downward force causes the joint material at the joint region to flow downward, deforming the joint. This makes it impossible to produce a satisfactory weld. Two-face structures (panels) include hollow members made of extruded aluminum alloy and honeycomb panels. Joining such panels has been accomplished by MIG welding and TIG welding. When friction stir welding is applied to such a joint, the joint is bent down or the material in the joint region is forced to flow down due to a downward force produced during the friction stir welding.

[0006] The inventor has found the above phenomena in a variety of experiments.

[0007] It is a first object of this invention to provide a satisfactory welded joint by minimizing deformation of the joint region when two faces are friction stir welded.

[0008] It is a second object of this invention to provide a satisfactory welded joint when one face is friction stir welded.

[0009] It is a third object of this invention to enable two faces to be welded together in a short time with little deformation.

[0010] The first object can be achieved by placing at the joint region a connecting member that joins two plates forming two faces.

[0011] The second object is realized by providing the members at the joint region with a raised portion that protrudes toward the friction stir welding tool side.

[0012] The third object is realized by disposing rotary tools for friction stir welding on both sides of the objects to be

welded, placing the rotation center of one of the tools on an extension of the rotation center of the other tool, and performing friction stir welding simultaneously.

BRIEF DESCRIPTION OF THE DRAWINGS

[0013] FIG. 1 is a vertical cross section of one embodiment of this invention.

[0014] FIG. 2 is a vertical cross section of FIG. 1 after friction stir welding.

[0015] FIG. 3 is a vertical cross section of another embodiment of this invention.

[0016] FIG. 4 is a vertical cross section of FIG. 3 after friction stir welding.

[0017] FIG. 5 is a vertical cross section of another embodiment of this invention.

[0018] FIG. 6 is a vertical cross section of FIG. 5 after friction stir welding.

[0019] FIG. 7 is a vertical cross section of still another embodiment of this invention.

[0020] FIG. 8 is a vertical cross section of FIG. 7 after friction stir welding.

[0021] FIGS. 9(A) to 9(D) are vertical cross sections showing steps in the procedure of friction stir welding of a further embodiment of this invention.

[0022] FIG. 10 is a vertical cross section of a further embodiment of this invention.

[0023] FIG. 11 is a vertical cross section of a further embodiment of this invention.

[0024] FIG. 12 is a vertical cross section of a further embodiment of this invention.

[0025] FIG. 13 is a vertical cross section of a further embodiment of this invention.

[0026] FIG. 14 is a vertical cross section of a further embodiment of this invention.

[0027] FIG. 15 is a perspective view of a structural body of a railway car.

DESCRIPTION OF THE PREFERRED EMBODIMENTS

[0028] The embodiment shown in FIG. 1 has a joint configuration of the abutting type between hollow members 31, 32 which are in the form of panels. The hollow members 31, 32 have vertical plates 36, 36 at their ends in the width direction. Before the welding, the vertical plates 36, 36 are disposed immediately beneath a rotary tool 50. The vertical plates 36, 36 are opposed to and in contact with each other. If they are spaced apart, the distance is small and approximately 1 mm. On the extension of the interface between the vertical plates 36, 36 lies the center of a projection 52. The vertical plates 36, 36 have a stiffness which is sufficiently strong to sustain the downward force mentioned earlier. The vertical plates 36 are perpendicular to two plates 33, 34 in each panel. The hollow members 31, 32 are formed by extruding an aluminum alloy. The upper and lower faces of the hollow member 31 are flush with the corresponding upper and lower faces of the hollow member 32.

[0029] That is, the hollow members 31, 32 have the same thickness. This is true also of the succeeding embodiments. During the friction stir welding process, the boundary 53 between a large-diameter portion 51 and the projection 52 of a small-diameter of the rotary tool 50 is situated above the upper surfaces of the hollow members 31, 32. Numeral 35 designates a plurality of members that are arranged in the

form of trusses to connect the two plates 36, 36. The hollow members 31, 32 each have bilaterally symmetrical end portions and are mounted on a bed (not shown) where they are fixed immovably. The bed also lies under the vertical plates 36, 36.

[0030] The friction stir welding process is performed by rotating the tool 50, plunging the projection 52 into the joint region of the hollow members 31, 32, and moving the projection 52 along the joint region. The rotating center of the projection 52 is located between the two vertical plates 36, 36.

[0031] FIG. 2 shows the two panels after they have been friction stir welded. Reference number 45 denotes the shape of a weld bead after welding. On the extension of the border line between the vertical plates 36, 36 the width center of the weld bead 45 is situated. The bead 45 lies in an area on the extension of the thickness of the vertical plates 36, 36. The depth of the weld bead 45 is determined by the height of the projection 52 at the lower end of the rotary tool 50 inserted in the joint region.

[0032] With this construction, because the vertical plates 36, 36 perpendicular to the plates 33, 34 sustain the vertical force produced during the friction stir welding, the joint region does not bend, offering a satisfactory joint as shown in FIG. 2. The vertical plate 36 is made perpendicular to the plates 33, 34 in each panel as much as possible.

[0033] The vertical plate 36 may be perforated to achieve a lighter weight. This is true also of the succeeding embodiments.

[0034] Welding of the lower side is carried out by turning the hollow panel members upside down after the welding of the one side is completed.

[0035] The embodiment of FIG. 3 has a vertical plate 36 at the end of one hollow member 31, but not at the opposing end of the other hollow member 32. Corners in the vertical direction of the vertical plate 36 of the hollow member 31 are recessed so as to receive the ends of projecting pieces 38, 38 of the hollow member 32. These recessed portions are open in a direction of the thickness of the hollow member 31 and in a direction perpendicular to the thickness direction (toward the hollow member 32 side). When the projecting pieces 38 are placed (superposed) on the recessed portions, there is actually a clearance between them although they are in contact with each other in the figure. There is also a gap between the front ends of these members (i.e., between the projecting pieces 38, 38 and the corners 33a, 34b). The abutting joint portions on the upper face side of the two hollow members 31, 32 and the vertical plate 36 are situated directly below the center of the rotary tool 50. The rotating center of the projection 52 of the welding tool 50 is disposed on an extension of the center line of the thickness of the vertical plate 36. That is, the joint region of the plate 33 (34) and plate 33 (34) is situated on the extension of the center line of the thickness of the vertical plate 36. The corners 33b, 34b extending from the plates 33, 34 to the recessed portions lie on an extension of the center line of the thickness of the vertical plate 36. Considering the gap between the corners 33b, 34b and the projecting pieces 38, the corners 33b, 34b are situated slightly to the left of the extension of the center line of the thickness of the vertical plate 36. The vertical plate 36 has a rigidity to support the downward force. The horizontal gap between the front ends of the projecting pieces 38 and the hollow member 31 is similar to that shown in FIG. 1. The height of the projection 52 of the welding tool 50 is approximately equal to the thickness of the projecting piece 38. The region that is plastic and fluid

extends below the projecting piece 38, and comes to have an area larger than the diameter of the projection 52, and the two hollow members 31, 32 are friction stir welded. It is desirable that the friction stir weld be so formed as to extend beyond the contact area between the underside of the projecting piece 38 and the vertical plate 36.

[0036] FIG. 4 shows the state of the joint after being welded. The weld bead 45 is formed such that the width center of the weld bead 45 is situated on an extension of the thickness center of the vertical plate 36.

[0037] To support the vertical force, it is desirable for the rotating center of the tool 50 to be located on the extension of the center line of the thickness of the vertical plate 36. To make the quantity of the joint of the left and right hollow members 31, 32 equal, it is desirable for the corners 33b, 34b to be situated on the extension of the thickness center line of the vertical plate 36. While the projection 52 of the tool 50 should preferably be placed in the range between extension lines of the thickness of the vertical plate 36, the thickness of the vertical plate 36 is determined by the vertical force, the position of the projection 52 and the strength of the vertical plate 36. Hence, there may be a case in which the thickness of the plate 36 is smaller than the diameter of the projection 52. In view of the possible errors of the position of the rotary tool 50 and those of the corners 33b, 34b, it is desirable for the corners 33b, 34b to be positioned in the range between extension lines of the thickness of the vertical plate 36, and at least a part of the projection 52 of the tool 50 to be situated in this range. This arrangement enables the vertical plate 36 to receive at least a part of the vertical force, substantially preventing the deformation of the joint. As a result, a satisfactory joint can be formed. When the bead 45 is taken as a reference, although the bead 45 is slightly larger than the projection 52, the same as above can be said. This is true also of the other embodiments.

[0038] Compared with the case of FIG. 1, this joint configuration can minimize a sinking in the surface of the joint region even when the horizontal gap between the projecting piece 38 and the hollow member 31 is large. As a result, the joint has a good appearance and requires a reduced amount of putty for painting. This is because the gap between the two members is terminated at a depth equal to the thickness of the projecting piece 38. It is also considered that this joint configuration can reduce the weight. Further, because one of the hollow members is fitted into the other, the positioning in the height direction of the two members can be accomplished easily. The ends of the hollow member 31 are bilaterally symmetrical in shape.

[0039] The ends of hollow member 32 are also bilaterally symmetrical. Alternatively, the hollow member 31 may have one end shaped as shown in FIG. 3 and the other end shaped like the end of the hollow member 32 of FIG. 3.

[0040] In the embodiment of FIG. 5, there is virtually no vertical plate 36 immediately below the corners 33b, 34b of the recessed portion of the hollow member 31. The right end of the vertical plate 36 lies on the extension of the corners 33b, 34b. On this extension the rotating center of the tool 50 is located. The end portion of the hollow member 31 is given a rigidity to sustain the vertical force by making the lower projecting piece 37 at the joint thicker and increasing the size of the arcs extending from the front ends of the projecting pieces 37 to the plate 36. The projecting pieces 38 of the other hollow member 32 are received in the recessed portions of the projecting pieces 37, as in the preceding embodiment of FIG.

3. The second hollow member **32** has a vertical plate **36** near the projections **38** for connecting the upper and lower plates **33, 34**. This arrangement prevents the joint region from being defective even when there is no vertical plate **36** directly below the corners of the recessed portions. It is noted, however, that below the range of the bead **45** there is a vertical plate **36** of the panel **31**. FIG. 6 shows the state after welding.

[0041] In the embodiment of FIG. 5, the plate **36** of the hollow member **32** may be removed.

[0042] FIG. 7 shows another embodiment, representing a variation of the preceding embodiment of FIG. 5, in which the joint region of the two hollow members **31, 32** is provided with raised portions **37a, 38a** protruding outside. This makes the joint region thick. The heights of the raised portions **37a, 38a** are equal. Other parts are similar to those of FIG. 5, except that the vertical plate **36** and the projections **37** are slightly thinner.

[0043] With this configuration, if there is a gap between the raised portions **37a** and **38a** before welding, the gap is filled with the material of the raised portions **37a, 38a**, when welded, improving the appearance and reducing the amount of putty required.

[0044] In conventional welded joints, the weld bead has a sunken portion or recess corresponding to the volume of the lost material **41** that has flowed down due to the downward force. In the joint configuration of FIG. 7, the rotary tool **50** plasticizes the raised portions **37a, 38a** and forces them downward making up for the lost volume of the material **41**. Thus, formation of recess can be prevented, providing a satisfactory welded joint. FIG. 8 shows the shape of bead **45** after welding. After welding, unnecessary parts, if any, are cut off as shown.

[0045] The raised portions **37a, 38a** can also be applied to the embodiments of FIGS. 1, 3 and 5 and to subsequent embodiments.

[0046] FIGS. 9(A)-9(D) show a further embodiment, which allows welding at the upper and lower faces from only one side. The ends of the hollow members **31, 32** on the lower side having projecting pieces **34a, 34a** protruding flush with the lower plates **34, 34** substantially toward the opposing hollow member sides. The front ends of the projecting pieces **34a, 34a** are virtually in contact with each other. The front ends of the upper plates **33, 33** are offset back from the front ends of the lower plates **34a, 34a**. The front ends of the upper plates **33, 33** are connected to the lower plates **34, 34** through the vertical plates **36, 36**. The vertical plates **36, 36** are connected to intermediate portions of the lower plates **34**. The top portions of the vertical plates **36, 36** are provided with recessed portions **39, 39** that receive a joint **60**. When mounted on the recessed portions **39, 39**, the upper surface of the joint **60** is flush with the upper face of the upper plates **33, 33**. The distance between the two vertical plates **36, 36** is long enough for the rotary tool **50** to be inserted and is as short as possible. The relation between the vertical plates **36** and the recessed portions **39** is the same as explained with reference to the embodiments of FIG. 5 and FIG. 7.

[0047] The welding procedure will be described below. In the state of FIG. 9(A), the abutting ends of the lower plates **34a, 34a** are welded by the rotary tool **50**. At this time, the hollow members **31, 32**, including the joint region of the plates **34a, 34a**, are mounted on a bed. The upper surface of the bed (that backs the bead) is flat. The height of the projection **52** of the rotary tool **50** is smaller than the thickness of the plates **34a, 34a**. This design ensures that the bottom surface

after welding is flat. Thus, the bottom side can easily be used as an outer surface of the structure of a railway car or a building (the outer surface being the surface on which no decorative plate is mounted). Generally, the upper face of the friction stir welded joint tends to be uneven (at a boundary portion **51**).

[0048] Next, as shown in FIG. 9(B), the joint **60** is mounted between the two hollow shape members **31, 32**. The joint **60** in the illustrated example is T-shaped in vertical cross section. When both ends of the joint **60** are placed on the recessed portions **39, 39**, the lower end of a vertical portion **61** has a clearance between it and the weld bead on the lower plate. The vertical portion **61** may be omitted.

[0049] Next, as shown in FIG. 9(C), the joint portion between the joint **60** and the hollow member **31** is friction stir welded by the rotary tool **50**. The rotary tool **50** need not be the same as used for the weld illustrated in FIG. 9(A).

[0050] Then, as shown in FIG. 9(D), the joint portion between the joint **60** and the hollow member **32** is friction stir welded by the rotary tool **50**.

[0051] This procedure allows the welding to be performed from one side and eliminates the need for inversion of the panels. With the inversion of the panels eliminated, there is an advantage that the time required for inversion and positioning and need for an inversion device are unnecessary, and even the assembly precision is improved.

[0052] FIG. 10 shows another embodiment, in which both the upper and lower sides of the hollow members **51, 52** are friction stir welded at the same time. A rotary tool **50a** for the lower side is disposed vertically below the welding tool **50** for the upper side. The projection **52** of the second welding tool **50a** faces up. The two welding tools **50, 50a** facing each other are moved at the same speed to perform friction stir welding. Denoted by **70, 70** are beds (tables). The rotating centers of the tools **50** and **50a** are on the same line on which the joint region of the hollow shape members **31, 32** is located.

[0053] Because with this arrangement the rotating center of the second tool **50a** is positioned on the extension of the rotating center of the first tool **50**, the forces applied to the panels balance with each other allowing the joint to be welded in a short time with little deformation. Further, because there is no need to invert the hollow members **31, 32**, the welding can be performed in a short time with little deformation of the joint.

[0054] This procedure can be applied to other embodiments.

[0055] The preceding embodiments have used hollow members as panels to be joined. The following embodiments show friction stir welding as applied to honeycomb panels. As shown in FIG. 11, the honeycomb panels **80a, 80b** comprise two surface plates **81, 82**, core members **83** having honeycomb-like cells, and edge members **84** arranged along the edges of the surface plates **81, 82**, with the core members **83** and the edge members **84** soldered to the surface plates **81, 82** to form integral structures. The surface plates **81, 82**, the core members **83** and the edge members **84** are made of aluminum alloy. The edge members **84** are made by extrusion and have a rectangular cross section. All sides of this rectangular cross section are greater in thickness than the surface plates **81, 82**. The vertical sides of the mutually contacting edge members **84, 84** have the same thickness as shown in FIG. 1. The two honeycomb panels **80a, 80b** have the same thickness.

[0056] The welding procedure in the embodiment of FIG. 11 corresponds to the one shown in FIG. 1. The height of the

projection **52** of the rotary tool **50** is larger than the thickness of the face plates **81, 82**. This allows the face plates **81, 82** and the edge members **84, 84** to be welded. The load acting on the panels **80a, 80b** is transmitted mainly by the edge members **84**. After being fabricated, the panels **80a, 80b** are assembled and friction stir welded.

[0057] The embodiment of FIG. 12 corresponds to the one shown in FIG. 3. The edge member **84** of the honeycomb panel **80a** has a generally rectangular cross section and has recesses at the corners. The edge member **84** of the honeycomb panel **80b** is like a channel, with its opening facing the honeycomb panel **80a**. The open ends of the edge member **84** are mounted on the recessed portions of the edge member **84** of the honeycomb panel **80a**.

[0058] The honeycomb panel corresponding to FIG. 5 can be fabricated in a similar manner.

[0059] FIG. 13 shows still another embodiment that corresponds to FIG. 7. After two honeycomb panels **80a, 80b** are assembled, a plate **86** is placed on the face plates **81, 81** and temporarily welded to them. The plate **86** makes up for the material that is plasticized and flows out. In FIG. 12, one vertical piece of the edge member of the honeycomb panel **80a** is removed. The vertical force is supported by the thickness of the horizontal piece of the edge member **84** and the surrounding parts.

[0060] FIG. 14 shows a further embodiment of this invention. The preceding embodiments up to FIG. 13 include panels having two faces (face plates), whereas the embodiment of FIG. 14 includes panels **91, 92** having virtually a single face (face plates **94, 94**). Friction stir welding is performed at two locations, at the abutting ends of the panels **91, 92**, the outside with face plates **94** and the inner side with no face plates. Therefore, the joint regions on the inner side are provided with narrow face plates (face plates **93, 93**). The narrow face plates **93, 93** are supported by vertical plates **96, 96**. In this example, too, the vertical plates **96** are virtually perpendicular to the face plates **93, 94**. The face plates **93, 94** are provided with raised portions **37a, 38a** similar to the ones shown in FIG. 7. The face plates **94, 94** have a plurality of reinforcing ribs (plates) **95, 95** at specified intervals. The ribs **95** are T-shaped in cross section. The top surfaces of the ribs **95** are flush with those of the face plates **93** of the joint region. To the top surfaces reinforcing members (such as pillars) may be welded, or the top surfaces serve as mounting seats for articles. Further, the face plates **93, 93** also serve as a seat for controlling the height of the tool **50**. A movable body carrying the tool **50** travels along the face plates **93, 93**. Because of the provision of the face plates **93, 94**, the panels **91, 92** can also be said to form a two-face structure. The panels **91, 92** are extruded shape members.

[0061] While FIG. 14 shows the vertical plates **96, 96** of the panels **91** and **92** opposing each other at the joint region, as in the configuration of FIG. 1, it is possible to place one of the vertical plates over the other, as shown in FIGS. 3, 5 and 7.

[0062] FIG. 15 shows an example of application of this invention to the structural body of a railway car. The structural body has side bodies **101**, a roof body **102**, a floor body **103**, and gable bodies **104** at the ends in the longitudinal direction. The side bodies **101** and the roof body **102** have panels **31, 32, 80a, 80b, 91, 92** whose long sides are oriented in the longitudinal direction of the car. The joint between the side bodies **101** and the roof body **102** and between the side bodies **101** and the floor body **103** is accomplished by MIG welding. The roof body **102** and the side bodies **101** are often shaped into

arcs in cross section. When the panels **91, 92** are used for the side bodies **101**, the side having the vertical plates **96** and ribs **96** is made to face to the interior of the car and the reinforcing members constitute pillars.

[0063] The panels **31, 32** of FIG. 9 may be combined in a mirror-image arrangement. The end of the projecting plate **34a** of each panel is placed on the recessed portion **39** of the plate **33** of the other panel. This obviates the use of the joint **60** and allows for simultaneous friction stir welding of the joint region both from above and below. The plates **33, 34a** can be provided with raised portions, as shown in FIG. 7.

What is claimed is:

1. A structure of a panel friction stir welded to a plate member, wherein:

said panel comprises a first plate, a second plate substantially parallel to said first plate, plural ribs for connecting said first plate and said second plate, and a vertical plate for connecting an end portion in a width direction of said first plate and said second plate and being substantially perpendicular to said first plate and said second plate;

said first plate of said panel and said plate member are friction stir welded; and

a friction stir welded bead formed between said first plate of said panel and said plate member lies at least in a range of a plate thickness of said vertical plate.

2. A structure according to claim 1, wherein a center in a width direction of said friction stir welded bead lies in a range of said plate thickness of said vertical plate of said panel.

3. A structure of a first panel friction stir welded to a second panel, wherein:

said first panel comprises a first plate, a second plate substantially parallel to said first plate, plural ribs for connecting said first plate and said second plate, and a vertical plate for connecting an end portion in a width direction of said first plate and said second plate and being substantially perpendicular to said first plate and said second plate;

said second panel comprises a first plate, a second plate substantially parallel to said first panel, and plural ribs for connecting said first plate and said second plate;

said first plate of said first panel and said first plate of said second panel are friction stir welded; and

a friction stir welded bead formed between said first plate of said first panel and said first plate of said second panel lies at least in a range of a plate thickness of said vertical plate of said first panel.

4. A structure according to claim 3, wherein a center in a width direction of said friction stir welded bead lies in a range of said plate thickness of said vertical plate of said first panel.

5. A structure of a first panel friction stir welded to a second panel, wherein:

said first panel comprises a first plate, a second plate substantially parallel to said first plate, plural ribs for connecting said first plate and said second plate, and a vertical plate for connecting an end portion in a width direction of said first plate and said second plate and being substantially perpendicular to said first plate and said second plate;

said second panel comprises a first plate, a second plate substantially parallel to said first plate of said second panel, and plural ribs for connecting said first plate of the second panel and said second plate of the second panel;

said first plate of said first panel and said first plate of said second panel are friction stir welded;

said second plate of said first panel and said second plate of said second panel are friction stir welded;
a friction stir welded bead formed between said first plate of said first panel and said first plate of said second panel lies at least in a range of a plate thickness of said vertical plate of said first panel; and
a friction stir welded bead formed between said second plate of said first panel and said second plate of said

second panel lies at least in said range of said plate thickness of said vertical plate of said first panel.

6. A structure according to claim 5, wherein a respective center in a width direction of both of the friction stir welded beads lies in a range of said plate thickness of said vertical plate of said first panel.

* * * * *