

(19) World Intellectual Property
Organization
International Bureau



(43) International Publication Date
10 November 2005 (10.11.2005)

PCT

(10) International Publication Number
WO 2005/106999 A1

(51) International Patent Classification⁷: **H01M 8/02**, 2/08

(21) International Application Number:
PCT/US2005/014344

(22) International Filing Date: 26 April 2005 (26.04.2005)

(25) Filing Language: English

(26) Publication Language: English

(30) Priority Data:
60/566,045 27 April 2004 (27.04.2004) US
11/112,122 22 April 2005 (22.04.2005) US

(71) Applicant (for all designated States except US): **BATTELLE MEMORIAL INSTITUTE** [US/US]; Pacific Northwest Division, Intellectual Property Division, P.O. Box 999, Richland, WA 99352 (US).

(72) Inventors; and

(75) Inventors/Applicants (for US only): **WEIL, Scott, K.** [US/US]; 172 Orchard Way, Richland, WA 99352 (US). **HARDY, John, S.** [US/US]; 410 Ash Street, Richland, WA 99352 (US).

(74) Agents: **BRANTON, Vincent, A.** et al.; Battelle Memorial Institute, P.O. Box 999 (MSIN K1-53), Richland, WA 99352 (US).

(81) Designated States (unless otherwise indicated, for every kind of national protection available): AE, AG, AL, AM, AT, AU, AZ, BA, BB, BG, BR, BW, BY, BZ, CA, CH, CN, CO, CR, CU, CZ, DE, DK, DM, DZ, EC, EE, EG, ES, FI, GB, GD, GE, GH, GM, HR, HU, ID, IL, IN, IS, JP, KE, KG, KM, KP, KR, KZ, LC, LK, LR, LS, LT, LU, LV, MA, MD, MG, MK, MN, MW, MX, MZ, NA, NI, NO, NZ, OM, PG, PH, PL, PT, RO, RU, SC, SD, SE, SG, SK, SL, SM, SY, TJ, TM, TN, TR, TT, TZ, UA, UG, US, UZ, VC, VN, YU, ZA, ZM, ZW.

(84) Designated States (unless otherwise indicated, for every kind of regional protection available): ARIPO (BW, GH, GM, KE, LS, MW, MZ, NA, SD, SL, SZ, TZ, UG, ZM, ZW), Eurasian (AM, AZ, BY, KG, KZ, MD, RU, TJ, TM), European (AT, BE, BG, CH, CY, CZ, DE, DK, EE, ES, FI, FR, GB, GR, HU, IE, IS, IT, LT, LU, MC, NL, PL, PT, RO, SE, SI, SK, TR), OAPI (BF, BJ, CF, CG, CI, CM, GA, GN, GQ, GW, ML, MR, NE, SN, TD, TG).

Published:

- with international search report
- before the expiration of the time limit for amending the claims and to be republished in the event of receipt of amendments

For two-letter codes and other abbreviations, refer to the "Guidance Notes on Codes and Abbreviations" appearing at the beginning of each regular issue of the PCT Gazette.

(54) Title: IMPROVED JOINT WITH APPLICATION IN ELECTROCHEMICAL DEVICES

(57) Abstract: A joint for use in electrochemical devices, such as solid oxide fuel cells (SOFCs), oxygen separators, and hydrogen separators, that will maintain a hermetic seal at operating temperatures of greater than 600°C, despite repeated thermal cycling excess of 600°C in a hostile operating environment where one side of the joint is continuously exposed to an oxidizing atmosphere and the other side is continuously exposed to a wet reducing gas. The joint is formed of a metal part, a ceramic part, and a flexible gasket. The flexible gasket is metal, but is thinner and more flexible than the metal part. As the joint is heated and cooled, the flexible gasket is configured to flex in response to changes in the relative size of the metal part and the ceramic part brought about by differences in the coefficient of thermal expansion of the metal part and the ceramic part, such that substantially all of the tension created by the differences in the expansion and contraction of the ceramic and metal parts is absorbed and dissipated by flexing the flexible gasket.



WO 2005/106999 A1

IMPROVED JOINT WITH APPLICATION IN ELECTROCHEMICAL DEVICES

5

[0001] The invention was made with Government support under Contract DE-AC05-76RL01830, awarded by the U.S. Department of Energy. The Government has certain rights in the invention.

10 RELATED APPLICATIONS

[0002] This application claims priority to US Provisional Application No. 60/566045, and U.S. Non-Provisional Application filed April 22, 2005, Application No. _____ the entire contents of which are incorporated herein by this reference.

15

TECHNICAL FIELD

[0003] This invention relates to electrochemical devices, including, without limitation, solid oxide fuel cells, oxygen separators, and hydrogen separators. More specifically, the present invention relates to improved joints utilized in
20 electrochemical devices, and methods of forming those joints.

BACKGROUND OF THE INVENTION

[0004] Those skilled in the art of electrochemical devices, including without limitation, solid oxide fuel cells, oxygen separators, and hydrogen
25 separators, recognize a need for improved seals at the interface between ceramic and metal parts utilized in these devices. For example, among solid

oxide fuel cell designs, the planar stack (pSOFC) has received growing attention because its compact nature affords high volumetric power density – a design feature of particular importance in transportation applications. With the advent of anode-supported cells that employ thin YSZ electrolytes, these devices can be
5 operated at reduced temperature (700 - 800°C) and still achieve the same current densities exhibited by their high-temperature, thick electrolyte-supported counterparts, as described in B.C.H. Steele, A. Heinzl (2001) Materials for fuel-cell technologies, *Nature*, **414**(X) 345-52. The entire contents of this, and each and every other patent, paper or other publication referenced herein is hereby
10 incorporated into this disclosure in its entirety by this reference. The lower operating temperature not only makes it possible to consider inexpensive, commercially available high temperature alloys for use in the stack and balance of plant, but also expands the range of materials that can be considered for device sealing.

15 **[0005]** Because SOFCs function under an oxygen ion gradient that develops across the electrolyte, hermeticity across this membrane is paramount. In a planar design, this means that the YSZ layer must be dense, must not contain interconnected porosity, and must be connected to the rest of the device with a high temperature, gas-tight seal of the type shown in Figure 1. One of the
20 fundamental challenges in fabricating pSOFCs is how to effectively seal the thin electrochemically active YSZ membrane against the metallic body of the device creating a hermetic, rugged and stable stack. Typical conditions under which these devices are expected to operate and to which the accompanying YSZ-to-metal seal will be exposed include: (1) an average operating temperature of
25 750°C; (2) continuous exposure to an oxidizing atmosphere on the cathode side

and a wet reducing gas on the anode side; and (3) an anticipated device lifetime of 10,000+ hours.

[0006] Two techniques are typically used by those skilled in the art to seal a planar stack; glass joining and compressive sealing. Inherent advantages and limitations are found with each method. For example, glass joining is a cost-effective and relatively simple method of bonding ceramic to metal. However, the final seal is typically brittle and non-yielding, making it particularly susceptible to fracture when exposed to tensile stresses such as those encountered during non-equilibrium thermal events or due to thermal expansion mismatches between the glass and joining substrates as described in K. Eichler, G. Solow, P. Otschik, W. Schaffrath (1999) BAS ($\text{BaO}\cdot\text{Al}_2\text{O}_3\cdot\text{SiO}_2$) glasses for high temperature applications, *J. Eur. Cer. Soc.*, **19**(6-7) 1101-4 and Z.G. Yang, K.S. Weil, D.M. Paxton, K.D. Meinhardt, J. W. Stevenson (2003) Considerations of glass sealing solid oxide fuel cell stacks, *in*: J. E. Indacochea, J. N. DuPont, T. J. Lienert, W. Tillmann, N. Sobczak, W. F. Gale, M. Singh (Eds.) *Joining of Advanced and Specialty Materials V*, ASM International, Materials Park, OH, 40-48.

[0007] In addition, as the initial glass seal begins to devitrify during the first few hours of high-temperature exposure, its engineered thermal expansion properties change significantly, ultimately limiting the number of thermal cycles and the rate of cycling that the stack is capable of surviving. Over time additional problems arise as the sealing material, typically barium aluminosilicate-based, reacts with the chromium- or aluminum oxide scale on the faying surface of the interconnect and forms a mechanically weak barium chromate or celsian phase along this interface as described in Z.G. Yang, K.S. Weil, K.D. Meinhardt, J.W.

Stevenson, D.M. Paxton, G.-G. Xia, D.-S. Kim (2002) Chemical compatibility of barium-calcium-aluminosilicate base sealing glasses with heat resistant alloys, *in*: J. E. Indacochea, J. N. DuPont, T. J. Lienert, W. Tillmann, N. Sobczak, W. F. Gale, M. Singh (Eds.) *Joining of Advanced and Specialty Materials V*, ASM International, Materials Park, OH, 116-24.

[0008] In compressive sealing, a compliant, high-temperature material is captured between the two sealing surfaces and compressed, using a load frame external to the stack. Because the sealing material conforms to the adjacent surfaces and is under constant compression during use, it forms a dynamic seal. That is, the sealing surfaces can slide past one another without disrupting the hermeticity of the seal and coefficient of thermal expansion (CTE) matching is not required between the ceramic cell and metallic separator. Unfortunately, this technology remains incomplete due to the lack of a reliable high-temperature sealing material that would form the basis of the compressive seal. A number of materials have been considered, including mica, nickel, and copper, but each has been found deficient for any number of reasons, ranging from oxidation resistance in the case of the metals to poor hermeticity and through-seal leakage with respect to the mica as described in S.P. Simner, J.W. Stevenson (2001) *Compressive mica seals for SOFC applications*, *J. Power Sources*, **102** (1-2) 310-6.

[0009] An additional difficulty is in designing the load frame, as it must be capable of delivering moderate-to-high loads in a high-temperature, oxidizing environment over the entire period of stack operation. Material oxidation and load relaxation due to creep, as well as added expense and additional thermal mass are all issues of concern with this seal design.

[0010] The inventors of the present disclosure recently developed an alternative method of ceramic-to-metal brazing specifically for fabricating high temperature solid-state devices such as oxygen generators described in J.S. Hardy, J.Y. Kim, K.S. Weil (in press) Joining mixed conducting oxides using an air-fired electrically conductive braze, *J. Electrochem. Soc.* Vol. 151, No. 8, pp. 5 j43-j49 and US Patent Application No.10/334,346. Referred to as air brazing, the technique differs from traditional active metal brazing in two important ways: (1) it utilizes a liquid-phase oxide-noble metal melt as the basis for joining and therefore exhibits high-temperature oxidation resistance and (2) the process is 10 conducted directly in air without the use of fluxes and/or inert cover gases. In fact, the strength of the bond formed during air brazing relies on the formation of a thin, adherent oxide scale on the metal substrate. The technique employs a molten oxide that is at least partially soluble in a noble metal solvent to pre-wet the oxide faying surfaces, forming a new surface that the remaining molten filler 15 material easily wets. A number of metal oxide-noble metal systems are suitable, including Ag-CuO, Ag-V₂O₅, and Pt-Nb₂O₅ as described in Z.B. Shao, K.R. Liu, L.Q. Liu, H.K. Liu, S. Dou (1993) Equilibrium phase diagrams in the systems PbO-Ag and CuO-Ag, *J. Am. Cer. Soc.*, **76** (10) 2663-4, A.M. Meier, P.R. Chidambaram, G.R. Edwards (1995) A comparison of the wettability of copper-copper oxide and silver-copper oxide on polycrystalline alumina, *J. Mater. Sci.*, 20 **30** (19) 4781-6, and R.S. Roth, J.R. Dennis, H.F. McMurdie, eds. (1987) *Phase Diagrams for Ceramists, Volume VI*, The American Ceramic Society, Westerville, OH.

[0011] While advances in sealing techniques such as the brazing 25 technique described above have improved the performance of ceramic to metal

joints in high temperature environments typical of electrochemical devices such as solid oxide fuel cells, there still exists a need for further improvements in these joint that allow them to operate over multiple cycles while maintaining a hermetic seal between the metal and ceramic parts.

5

SUMMARY OF THE INVENTION

[0012] Thus, it is an object of the present invention to provide a joint between a metal and a ceramic part that will maintain a hermetic seal at operating temperatures of greater than 600°C. It is a further object of the present invention to provide a joint between a metal and a ceramic part that will maintain a hermetic seal despite repeated thermal cycling in excess of 600°C. It is a further object of the present invention to provide a joint between a metal and a ceramic part that will maintain a hermetic seal in a hostile operating environment, such as an opeting environment where one side of the joint is continuously exposed to an oxidizing atmosphere and the other side is continuously exposed to a wet reducing gas. It is a further object of the present invention to provide a joint between a metal and a ceramic part that will maintain a hermetic seal for a lifetime of 10,000+ hours of operation.

[0013] These and other objects of the present invention are accomplished by providing a joint as shown in Figure 2. The joint of the present invention is formed of a metal part **1**, a ceramic part **2**, and a flexible gasket **3**. One side of the flexible gasket **3** is attached to the metal part **1** to form a hermetic seal between the two. The other side of the flexible gasket **3** is bonded to the ceramic part **2** to form a separate hermetic seal between the flexible gasket **3** and the ceramic part **2**. The flexible gasket **3** is made of metal, preferably the a

high temperature oxidation resistant metal with a coefficient of thermal expansion between that of metal part **1** and ceramic part **2**. However, the flexible gasket **3** is thinner and more flexible than the metal part **1**. As the joint is heated and cooled, differences in the material's coefficient of thermal expansion cause the ceramic part **2** and metal part **1** to expand and contract at different rates. The flexible gasket **3** is thus configured to flex in response to these changes in temperature, up to and including changes in temperature in excess of 600° C while maintaining a hermetic seal between the ceramic part **2** and the flexible gasket **3**, and between the metal part **1** and the flexible gasket **3**.

[0014] Preferably, the flexible gasket **3** has greater flexibility than the metal part **1**. One reason the joint is able to maintain a hermetic seal with the metal part **1** and the ceramic part **2** is because the increased flexibility in the flexible gasket **3** causes substantially all of the tension created by the differences in the expansion and contraction of the ceramic **2** and metal parts **1** to be absorbed and dissipated by flexing the flexible gasket **3**.

[0015] The joint of the present invention preferably utilizes bonds between the ceramic part **2** and the flexible gasket **3** formed of brazed silver copper oxide alloys in air. Suitable bonds may also be formed by thin films of suitable glasses, such as those disclosed in US Patent No. 6,430,966, and polymeric pre-ceramic precursor such as those disclosed in C.A. Lewinsohn and S. Elangovan, Ceramic Engineering and Science Proc. Vol. 24, American Ceramic Soc., p. 317, (2003). The bond between the flexible gasket **3** and the metal part **1** may also be formed of brazed silver copper oxide alloys in air. Alternatively, any means conventionally used to bond metal parts, such as welding, may be utilized.

[0016] The joint of the present invention finds particular utility in applications including, but not limited to, electrochemical devices such as solid oxide fuel cells (SOFCs), oxygen separators, and hydrogen separators. In these and other application, it may be preferred that the ceramic part **2** is an electrolyte. For example, when utilized in certain SOFCs, it is preferred that the ceramic be an electrolyte formed of yttria stabilized zirconia (YSZ). In these and other applications, it is preferred that the flexible gasket **3** be formed of a high temperature stainless steel, thus allowing more flexibility in choosing the alloy for metal part **1**. Depending on the specific application, the stainless steel used for the flexible gasket **3** may be an alumina forming stainless steel, a chromia forming stainless steel, or a superalloy, and the metal part **1** may be an alumina forming stainless steel, a chromia forming stainless steel, or a superalloy.

[0017] The configuration of devices such as SOFCs, oxygen separators, and hydrogen separators, as well as the use of alumina forming stainless steels, chromia forming stainless steels, and superalloys are well understood by those having ordinary skill in the art. Further, those having ordinary skill in the art are well aware of the need for improved joints between the metal to ceramic joint in these devices, to improve the ability of the joint to maintain a hermetic seal across multiple thermal cycles in hostile operating environments. Accordingly, it is not necessary to recite a detailed description of the design and operation of each of these devices to allow those having ordinary skill in the art to appreciate the advantages of the present invention. With the benefit of the joint described in this disclosure, those having ordinary skill in the art will readily appreciate the advantages and configurations with which the joints of the present invention may be utilized in such devices. Accordingly, while the joints of the present invention

is described in detail herein below in the context of a SOFC device, those having ordinary skill in the art will readily appreciate that the joints of the present invention present the same advantages when deployed in other electrochemical devices, and the detailed description should be recognized as exemplary in nature. While this preferred embodiment of the present invention will be shown and described, it will be apparent to those skilled in the art that many changes and modifications may be made without departing from the invention in its broader aspects. The appended claims are therefore intended to cover all such changes and modifications as fall within the true spirit and scope of the invention.

10

BRIEF DESCRIPTION OF THE DRAWINGS

[0018] The following detailed description of the embodiments of the invention will be more readily understood when taken in conjunction with the following drawing, wherein:

15 **[0019]** Figure 1 is an illustration of a typical configuration of a solid oxide fuel cell used in a solid oxide fuel cell stack.

[0020] Figure 2 is an illustration of the joint of the present invention showing the arrangement of the metal part, the ceramic part, and the flexible gasket.

20 **[0021]** Figure 3 is a composite cross-sectional micrograph of a joint fabricated in proof of principle experiments to demonstrate the present invention.

[0022] Figure 4 is a graph showing the rupture strength of the joints fabricated in proof of principle experiments to demonstrate the present invention in the as-joined and as-cycled conditions.

DETAILED DESCRIPTION OF THE PREFERRED EMBODIMENTS

5 **[0023]** A number of high temperature alloys were considered for use as the metal gasket in experiments conducted to demonstrate joints of the present invention. As part of this proof-of-concept study, the initial materials screening analysis focused on four key properties: high oxidation resistance, low stiffness, high ductility, and low cost. Based on these factors, a commercial alumina-
10 forming ferritic steel was selected as the foil membrane: DuraFoil (22% Cr, 7% Al, 0.1%La+Ce, bal. Fe, manufactured by Engineered Materials Solutions, Inc. Attleboro, Mass). The DuraFoil was supplied as 50 μ m thick sheet. It was then sheared into 3 cm x 3 cm samples, annealed in vacuum at 900°C for 2hrs, and stamped into cap-shaped washers using a die designed specifically for this
15 purpose. The stamped foils were ultrasonically cleaned in soap and water, and then flushed with acetone to remove the lubricant from the stamping operation.

[0024] Each foil washer was bonded to a 6.2mm thick Haynes 214 washer, with an outside diameter of 4.4cm and an inside diameter of 1.5cm, using BNi-2 braze tape purchased from Wall Colmonoy, Inc. Madison Heights,
20 MI. An alumina-scale forming nickel-based superalloy, Haynes 214 displays excellent oxidation resistance at temperatures in excess of 1000°C, but also exhibits an average CTE of 15.7 m/m·K, which is almost 50% higher than that of the anode-supported bilayer, which consists of a thick porous layer of Ni chemically bonded to a dense, nonporous YSZ membrane. (CTE = 10.6 μ m/m
25 ·K).

[0025] Fabrication of the specimen was completed by joining the stamped Durafoil component to the Haynes 214 using BNi-2 braze tape. A second

brazing operation was conducted by air brazing the top side of the stamped foil to the YSZ side of a 25mm diameter bilayer disc using a Ag-4mol% CuO paste. Joining was conducted by applying a concentric 24mm ring of braze paste to the Durafoil washer using an automated pressure-driven dispenser. After allowing
5 the paste to dry, the bilayer was placed YSZ-side down onto the washer and dead-loaded with 25g of weight. The assembly was heated in air at 20°C/min to 1050°C and held at temperature for 15min before furnace cooling to room temperature.

[0026] Thermal cycle testing was conducted by heating the specimens in
10 air at a rate of 75°C/min to 750°C, holding at temperature for ten minutes, and cooling to $\leq 70^\circ\text{C}$ in forty minutes before re-heating under the same conditions. A minimum of six specimens was tested for each test condition. Microstructural analysis was conducted on polished cross-sectioned samples using a JEOL JSM-5900LV scanning electron microscope (SEM) equipped with an Oxford
15 energy dispersive X-ray analysis (EDX) system.

[0027] The specimens were characterized via rupture and thermal cycle testing and subsequently analyzed by SEM and EDS. Shown in Figure 3 is a composite cross-sectional micrograph of a joint according to the present invention. The joint was well sealed, as determined by hermeticity testing
20 conducted prior to metallographic analysis. The entire seal between the metal gasket and the metal part is approximately 1.1mm thick, although it is expected that this can be readily reduced simply by altering the geometry of the DuraFoil stamping. On the ceramic side of the seal, the CuO-Ag braze forms a robust joint between the YSZ and the alumina scale of the DuraFoil. Note that the
25 braze is thicker toward the center of the specimen. No reaction zone is observed

at the YSZ/braze interface, however a 10 – 15 μm thick zone forms on the DuraFoil due to reaction between the Al_2O_3 scale and the CuO in the braze. The dominant product is the mixed oxide phase $2\text{CuO}\cdot\text{Al}_2\text{O}_3$.

[0028] Results from rupture testing are shown in Figure 4. Each joint was
5 found to be hermetic up to the maximum pressure (60 psi) tested during initial leak testing. More extensive pressure testing up to the point of rupture indicated no failure in any of the seals, even in the specimens that underwent as many as twenty rapid thermal cycles. As with the air brazed specimens above, failure occurred in the ceramic disc.

CLAIMS

The invention claimed is:

1. A joint comprising:
 - a. a metal part,
 - 5 b. a ceramic part,
 - c. and a flexible gasket wherein
 - d. the flexible gasket is attached to the metal part on one side and
hermetically bonded to the ceramic part on the other side and configured
to flex in response to changes in the size of the metal part and the ceramic
10 part brought about by temperature changes while maintaining a hermetic
seal between said flexible gasket and both said metal part and said
ceramic part.
2. The joint of claim 1 wherein the flexible gasket has greater flexibility than the
metal part.
- 15 3. The joint of claim 1 wherein said bond between said ceramic part and said
flexible gasket is formed of brazed silver copper oxide alloys in air.
4. The joint of claim 1 wherein said bond between said ceramic part and said
flexible gasket is formed of a thin film of glass.
5. The joint of claim 1 wherein said bond between said ceramic part and said
20 flexible gasket is formed of a polymeric pre-ceramic precursor.
6. The joint of claim 1 wherein said ceramic is an electrolyte.
7. The joint of claim 6 wherein said electrolyte is yttria stabilized zirconia.
8. The joint of claim 1 wherein the joint is a part of a solid oxide fuel cell.
9. The joint of claim 1 wherein the joint is a part of an oxygen separator.
- 25 10. The joint of claim 1 wherein the joint is a part of a hydrogen separator.
11. The joint of claim 1 wherein said metal part is a high temperature stainless steel.

12. The joint of claim 11 wherein said stainless steel is an alumina forming stainless steel.
13. The joint of claim 11 wherein said stainless steel is chromia forming stainless steel.
- 5 14. The joint of claim 1 wherein said metal part is a superalloy.
15. The joint of claim 1 wherein said gasket is a high temperature stainless steel.
16. The joint of claim 15 wherein said stainless steel is an alumina forming stainless steel.
17. The joint of claim 15 wherein said stainless steel is chromia forming stainless steel.
- 10 18. The joint of claim 15 wherein said gasket is a superalloy.

Figure 1

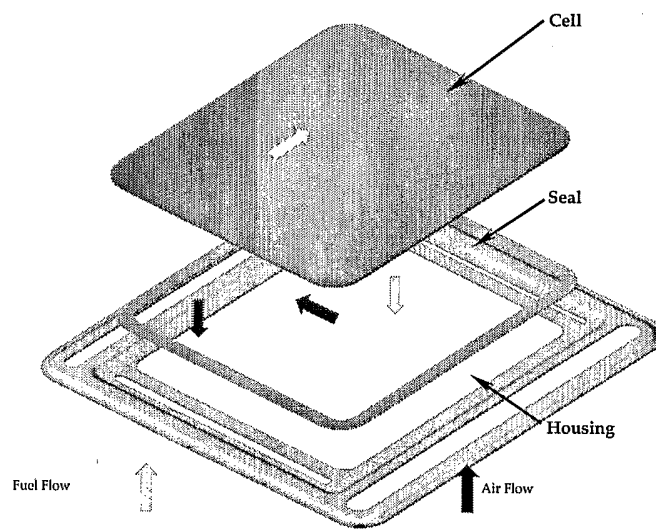

Figure 2

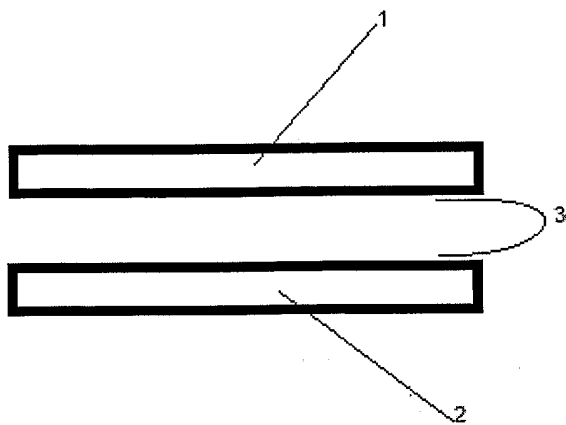

Figure 3

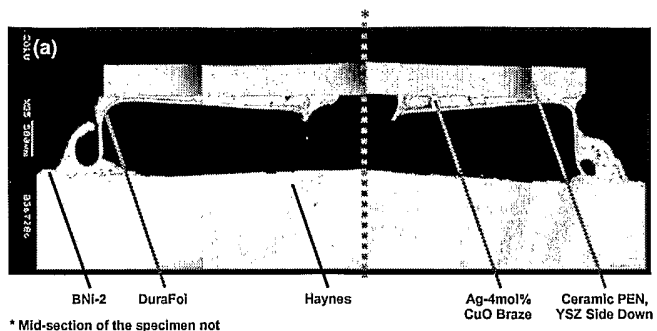
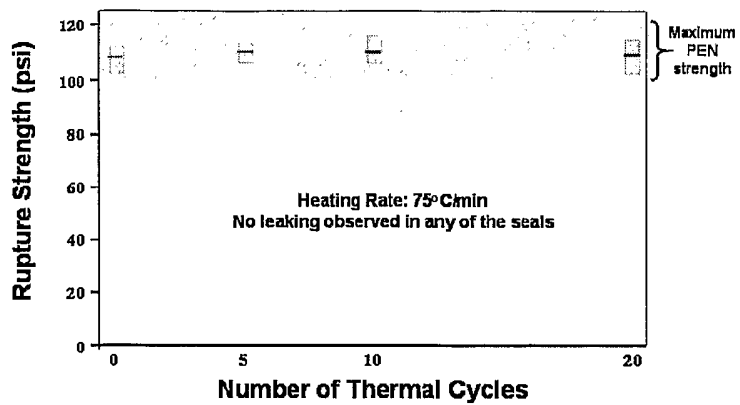

Figure 4



INTERNATIONAL SEARCH REPORT

International Application No
PCT/US2005/014344

A. CLASSIFICATION OF SUBJECT MATTER
IPC 7 H01M8/02 H01M2/08

According to International Patent Classification (IPC) or to both national classification and IPC

B. FIELDS SEARCHED

Minimum documentation searched (classification system followed by classification symbols)
IPC 7 H01M

Documentation searched other than minimum documentation to the extent that such documents are included in the fields searched

Electronic data base consulted during the international search (name of data base and, where practical, search terms used)

EPO-Internal, PAJ, INSPEC, COMPENDEX

C. DOCUMENTS CONSIDERED TO BE RELEVANT

Category °	Citation of document, with indication, where appropriate, of the relevant passages	Relevant to claim No.
X	US 2004/060967 A1 (YANG ZHENGUO ET AL) 1 April 2004 (2004-04-01)	1-14
Y	page 1, paragraphs 6,7,11; claims 1-8	15-18
Y	PATENT ABSTRACTS OF JAPAN vol. 1997, no. 07, 31 July 1997 (1997-07-31) & JP 09 067672 A (TOKYO GAS CO LTD), 11 March 1997 (1997-03-11) abstract	15-18
A	US 2003/132270 A1 (WEIL K. SCOTT ET AL) 17 July 2003 (2003-07-17) page 1, paragraph 2-4; claims 1-5	1-18
A	US 6 430 966 B1 (MEINHARDT KERRY D ET AL) 13 August 2002 (2002-08-13) the whole document	1-18

Further documents are listed in the continuation of box C.

Patent family members are listed in annex.

° Special categories of cited documents:

- *A* document defining the general state of the art which is not considered to be of particular relevance
- *E* earlier document but published on or after the international filing date
- *L* document which may throw doubts on priority claim(s) or which is cited to establish the publication date of another citation or other special reason (as specified)
- *O* document referring to an oral disclosure, use, exhibition or other means
- *P* document published prior to the international filing date but later than the priority date claimed

- *T* later document published after the international filing date or priority date and not in conflict with the application but cited to understand the principle or theory underlying the invention
- *X* document of particular relevance; the claimed invention cannot be considered novel or cannot be considered to involve an inventive step when the document is taken alone
- *Y* document of particular relevance; the claimed invention cannot be considered to involve an inventive step when the document is combined with one or more other such documents, such combination being obvious to a person skilled in the art.
- *&* document member of the same patent family

Date of the actual completion of the international search

16 August 2005

Date of mailing of the international search report

29/08/2005

Name and mailing address of the ISA
European Patent Office, P.B. 5818 Patentlaan 2
NL - 2280 HV Rijswijk
Tel. (+31-70) 340-2040, Tx. 31 651 epo nl,
Fax: (+31-70) 340-3016

Authorized officer

Boussard, N

INTERNATIONAL SEARCH REPORT

International Application No
PCT/US2005/014344

Patent document cited in search report	Publication date	Patent family member(s)	Publication date
US 2004060967	A1	AU 2003278867 A1 WO 2004030121 A1	19-04-2004 08-04-2004
JP 09067672	A	NONE	
US 2003132270	A1	AU 2003205086 A1 CA 2472378 A1 EP 1485332 A1 WO 03059843 A1	30-07-2003 24-07-2003 15-12-2004 24-07-2003
US 6430966	B1	AU 6498000 A CA 2380101 A1 EP 1200371 A1 JP 2003506304 T WO 0109059 A1 US 6532769 B1	19-02-2001 08-02-2001 02-05-2002 18-02-2003 08-02-2001 18-03-2003