

(19) World Intellectual Property Organization
International Bureau



(43) International Publication Date
5 June 2008 (05.06.2008)

PCT

(10) International Publication Number
WO 2008/066954 A1

(51) International Patent Classification:
H04N 13/04 (2006.01)

(21) International Application Number:

PCT/US2007/069458

(22) International Filing Date: 22 May 2007 (22.05.2007)

(25) Filing Language: English

(26) Publication Language: English

(30) Priority Data:
11/565,185 30 November 2006 (30.11.2006) US

(71) Applicant (for all designated States except US): **UNIVERSAL CITY STUDIOS LLLP** [US/US]; 100 Universal City Plaza, Universal City, CA 91608 (US).

(72) Inventors; and

(75) Inventors/Applicants (for US only): **TROWBRIDGE, Scott, R.** [US/US]; 1036 Oakdale Street, Windermere, FL 34786 (US). **BLUM, Steven, C.** [US/US]; 7718 Bardmoor Hill Circle, Orlando, FL 32835 (US). **SCHWARTZ, Justin, Michael** [US/US]; 4887 New Broad Street, Apt. 2002, Orlando, FL 32814 (US). **MCQUILLIAN, Brian** [US/US]; 8007 Bridgestone Drive, Orlando, FL 32835 (US).

(74) Agents: **WINTER, Catherine, J.** et al.; General Electric Company, Global Patent Operation, 187 Danbury Road, Suite 204, Wilton, CT 06897 (US).

(81) Designated States (unless otherwise indicated, for every kind of national protection available): AE, AG, AL, AM, AT, AU, AZ, BA, BB, BG, BH, BR, BW, BY, BZ, CA, CH, CN, CO, CR, CU, CZ, DE, DK, DM, DZ, EC, EE, EG, ES, FI, GB, GD, GE, GH, GM, GT, HN, HR, HU, ID, IL, IN, IS, JP, KE, KG, KM, KN, KP, KR, KZ, LA, LC, LK, LR, LS, LT, LU, LY, MA, MD, MG, MK, MN, MW, MX, MY, MZ, NA, NG, NI, NO, NZ, OM, PG, PH, PL, PT, RO, RS, RU, SC, SD, SE, SG, SK, SL, SM, SV, SY, TJ, TM, TN, TR, TT, TZ, UA, UG, US, UZ, VC, VN, ZA, ZM, ZW.

(84) Designated States (unless otherwise indicated, for every kind of regional protection available): ARIPO (BW, GH, GM, KE, LS, MW, MZ, NA, SD, SL, SZ, TZ, UG, ZM, ZW), Eurasian (AM, AZ, BY, KG, KZ, MD, RU, TJ, TM), European (AT, BE, BG, CH, CY, CZ, DE, DK, EE, ES, FI, FR, GB, GR, HU, IE, IS, IT, LT, LU, LV, MC, MT, NL, PL, PT, RO, SE, SI, SK, TR), OAPI (BF, BJ, CF, CG, CI, CM, GA, GN, GQ, GW, ML, MR, NE, SN, TD, TG).

Declarations under Rule 4.17:

— as to applicant's entitlement to apply for and be granted a patent (Rule 4.17(ii))

[Continued on next page]

(54) Title: TIME-SLICED MULTIPLEXED IMAGE DISPLAY

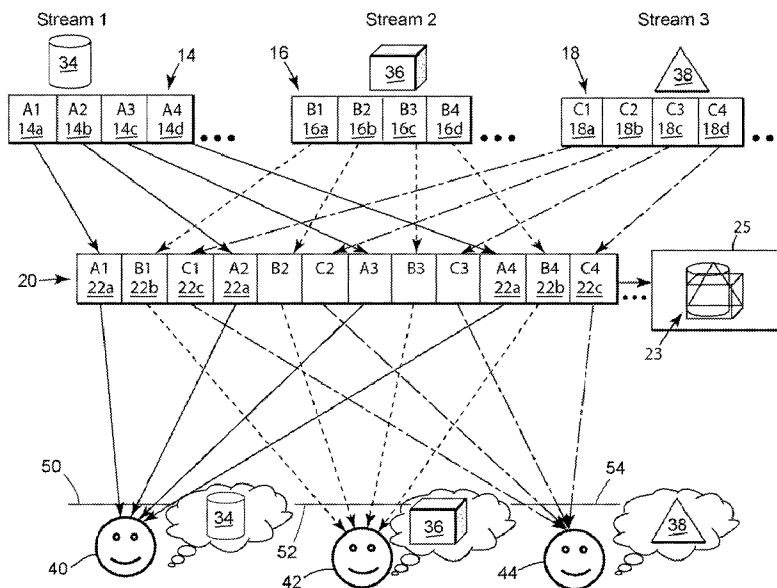

(57) Abstract: A device for displaying multiple image streams each comprising multiple image frames that entertains multiple viewers includes at least three image generators for generating at least three separate image streams that each include multiple image frames. An image multiplexer is provided for interleaving image frames of each image stream to produce an interleaved image stream and a display is provided for showing the interleaved image stream. Shutter glasses (and/or polarizers) filter the interleaved image stream, thereby separating one image stream for viewing by one viewer. A method of displaying multiple image streams is also presented 2D or 3D images can be displayed.

WO 2008/066954 A1



— *as to the applicant's entitlement to claim the priority of the earlier application (Rule 4.17(iii))*

Published:

— *with international search report*

TIME-SLICED MULTIPLEXED IMAGE DISPLAY

Cross Reference to Related Applications

This application claims benefit of U.S. Patent Application Serial No. 11/565,185, filed November 30, 2006, entitled "Time-Sliced Multiplexed Image Display" the entire contents of which is incorporated herein by reference to the extent necessary to make and use the present invention.

Background of the Invention

The field of the invention relates to motion picture display and viewing, and in particular, to a new and useful apparatus and method for displaying multiple image streams for individual viewers to perceive only a selected subset of the total set of projected image streams. The invention is well suited for use in amusement parks or theme parks, as well as in movie theaters and other places where display screens are used.

A conventional television show or theatrical film or other "moving picture" display is comprised of multiple still images shown in rapid succession on a screen or other display surface. Typically, the still images forming a moving picture are displayed at a rate of about 24-30 frames per second and are often synchronized with sound. The images impart the effect of motion because the human eye cannot perceive distinct changes in frames at rates greater than about 20 frames per second and blur the changes into the illusion of motion. Similarly, the human eye does not perceive flickering at rates above approximately 50 frames per second due to visual persistence. The above phenomenon has been used since the beginning of the 20th century to produce moving pictures, or movies. Thomas Edison, the inventor of the motion picture camera, needed to balance the needs of human perception with the need to minimize the amount of film that needed to be taken. He determined experimentally that 10 frames per second sufficed to provide the illusion of continuous motion. He also determined that viewers were quite annoyed by 10

flashes per second caused by the shutter opening and closing to accommodate motion of the film between looks. This phenomenon was simply addressed by having the shutter open and close three times for each single motion of the film, producing a 30 flash per second presentation that was well received by viewers.

Now, when a group of viewers watch a conventional television or movie theater screen, they each see the same image stream and have the same viewing experience. The display produces only a single image that is shared by the entire group viewing the screen.

Three-dimensional, or 3D, displays which have two different images forming a stereoscopic image in a single frame are also popular. The images can be separated by light polarization for projected images, or color, or via time-sequenced shuttering equipment. For images separated by polarization, one method would be for images for each eye to be polarized orthogonally to one another. The viewer is given polarized lenses to look through, which are coordinated with the projected image polarization for that eye, such that only the intended image reaches each eye. For images separated by color, each component of the stereoscopic image is presented in a different color within a single frame. For images that are time sequenced, a shuttering system presents the left and right images sequentially, and the observer wears glasses with shuttering mechanisms synchronized with the projection such that light is allowed to pass only when the appropriate image is illuminated. A person wearing glasses with lenses designed to filter images for each eye views the component images of the frame, one per eye, and human vision recombines the images into a single image having a three-dimensional appearance. A 3D image may look discolored and distorted when viewed without the appropriate aforementioned filtering mechanisms. Similar to conventional 2D images on a movie theater or television screen or other projection surface, observers viewing a conventional 3D display all see the same image.

It is important in the field of theme parks and amusements to create individual or personal experiences for guests. Large projection screens with image streams are used to immerse a large number of guests in a themed environment at one time. Each

guest views the same images projected onto the screen as is seen by all the other guests in the venue. Each guest has a limited interactive experience in such a setting because of the number of people simultaneously having identical experiences. Additionally, were interactive components for each guest in a large audience to be displayed simultaneously, causing many individual interactive elements to share the same screen space simultaneously, confusion and a greatly diminished guest experience would result. Furthermore, sequencing interactive elements on a large audience display is not usually possible, as the total experience time may be as short as two to three minutes in a typical theme park venue.

One method for presenting multiple users in a group with individual viewing experiences is to use virtual reality (VR) glasses. VR glasses typically present each user with a single image directly in front of their eyes, with all other surroundings blocked out by the VR glasses. VR glasses can be used to present different images to each individual in a small group since the input for the VR glasses can be made unique. However, VR glasses are impractical for use with large crowds of people due to the cost and volume of equipment required. The equipment must be unusually mechanically robust to resist abuse by guests and other wear and tear damage, and sanitizing between uses is logistically difficult and reduces equipment life. Further, it is difficult for individuals wearing the headsets to share the experience, as the glasses block out all surroundings.

Presently, no desirable methods exist for effectively creating different shows or experiences for individuals or smaller groups in larger crowds. Accordingly, a need exists for being able to create different shows or environments for individual guests or small selected groups of guests within a larger group on the same display screen to create satisfying personal experiences for each guest, and to thereby enhance the overall theme park or amusement experience.

Brief Description of the Invention

A device for displaying multiple image streams comprising multiple image frames that entertains multiple viewers comprises at least three image generators for generating at least three separate image streams each comprising multiple image frames and wherein at least one image generator is configured for at least one viewer input. An image multiplexer is provided for interleaving the image frames of each image stream to produce an interleaved image stream and a display is provided for showing the interleaved image stream.

According to one particular aspect of the invention, a filtering mechanism is also provided that comprises at least one shutter that is synchronized to the display of the desired frames in the interleaved image stream. The filtering mechanism is interposed between the viewer and display medium.

In another particular aspect of the invention, the interleaved image stream is superimposed on a background image stream that is visible to all viewers. When multiple image projectors are used to combine the images for viewers, the images from other projectors may be subtracted out prior to projection so as not to cause distortion in the combined image. The combination of a background image stream and a selected subset of filtered image streams is passed by the viewer's filtering mechanism, such as a shuttering filter.

In another embodiment of the invention, a method of displaying multiple image streams comprising multiple image frames for entertaining multiple viewers, comprises generating at least three separate image streams each comprising multiple image frames and providing for input from at least one viewer to one of the separate image streams; interleaving image frames of each image stream to produce an interleaved image stream; and displaying the interleaved image stream.

The various features of novelty which characterize the invention are pointed out with particularity in the claims annexed to and forming a part of this disclosure. For a better understanding of the invention, its operating advantages and benefits obtained by its uses, reference is made to the accompanying drawings and descriptive matter.

The accompanying drawings are intended to show examples of the many forms of the invention. The drawings are not intended to show the complete range of ways the invention can be made and used. Changes to and substitutions of the various components of the invention can of course be made. The invention resides as well in sub-combinations and sub-systems of the elements described, and in methods of using them.

Brief Description of the Drawings

Fig. 1 is a schematic of a display system in accordance with one embodiment of the invention;

Fig. 2 is a schematic of a display system in accordance with a further embodiment of the invention;

Fig. 3 is a timing chart in accordance with another embodiment of the invention;

Fig. 4 is a timing chart showing an alternative embodiment of the invention; and

Fig. 5 is a timing chart illustrating a still further alternative embodiment of the invention.

Detailed Description of the Invention

Referring now to the drawings in which like reference numerals are used to indicate the same or related elements, Fig. 1 illustrates a display system in which images 34, 36, 38 are depicted in image streams 14, 16, 18, respectively, for combining into a single interleaved image stream 20. Each of the image streams 14, 16, 18 comprise multiple frames A1 through A4, labeled 14a-d, B1 through B4, labeled 16a-d, C1 through C4, labeled 18a-d, respectively. The interleaved image stream 20 comprises multiple image frames labeled as 22a-c, repetitively, which correspond to particular image frames from each image stream 14, 16 and 18, respectively. It should be noted that the image 34, 36, 38 in each stream 14, 16, 18 may change between frames 14a-d, 16a-d, 18a-d, or it may remain constant for a period of time; in order to impart the

illusion of motion, the images 34, 36, 38 change with time. Each stream 14, 16, 18 may have any number of frames. It is preferable that each stream 14, 16, 18 have the same number of frames so that the interleaved image stream 20 displays an image for each stream until the interleaved image stream 20 ends. Further, while three separate image streams 14, 16, 18 are illustrated, the number should not be seen as limiting; as few as two independent image streams 14, 16 may be employed, or multiple streams may be combined to form the interleaved image stream 20. The image streams 14, 16, 18 may be combined in any order in the interleaved image stream 20; that is, it is not essential that the order is 1, 2, 3, 1, 2, 3. The order of the combined images 14a-d, 16a-d, 18a-d is only limited by the fact that a certain number of images from one of the image streams 14, 16, 18 must be presented to a viewer each second with high enough frequency to avoid visible frame changes or flickering, and any filtering mechanism 50, 52, 54 is synchronized to the image frame 14a-d, 16a-d, 18a-d display order.

As illustrated in Fig. 1, images 34, 36, 38 represent three different objects – a cylinder, a cube and a triangle. As will be explained further herein, the images 34, 36, 38 presented can all be two-dimensional, in 3D form, or a combination of image types. Thus, for example, the cylinder 34 and cube 36 images may be presented in 2D or 3D, while the triangle 38 is a 2D image. As explained below, the viewers 40, 42, 44 are each provided with means for viewing a 2D or a 3D image and the system is operated accordingly.

The frames 14a-d, 16a-d, 18a-d forming the image of each object are combined in a predetermined manner to produce the interleaved image stream 20. If the interleaved image stream 20 is viewed without filtering, a composite, incoherent, image 23 appears on display media 25. Display media 25 may be a video screen, a projection screen, a television or computer monitor or another device capable of displaying the interleaved image stream 20. In one alternative, the display media 25 may be a lenticular lens, so that multiple images can be projected at once in the image stream 20, and the lens separates the images for viewers at different physical positions relative to the lens.

Three viewers 40, 42, 44 are shown in Fig. 1 who each view the interleaved image stream 20. A filter mechanism 50, 52, 54 is interposed between each viewer 40, 42, 44 and the display media 25. The filter mechanisms 50, 52, 54 are operated so that each viewer 40, 42, 44 sees only one of the images in the interleaved image stream 20. The filter mechanisms 50, 52, 54 are shuttering devices that can be implemented as any of optical, electro-optical, mechanical or electro-mechanical, chemical and electro-chemical. The mechanisms 50, 52, 54 can be composed solely of or include polarization or other filtering. When the filter mechanisms 50, 52, 54 are shuttered, no image passes, while when the shutter is opened, an image is visible by the eyes of the respective viewer 40, 42, 44. Each of the filter mechanisms 50, 52, 54 includes a synchronization device for synchronizing the shuttering of the filter mechanism with the display of one of the image streams 14, 16, 18 in the interleaved image stream 20, so that only the selected image stream 14, 16, 18 is visible on the display media 25 as viewed through the particular filter mechanism 50, 52, 54. The display time for each frame 22a-c in the interleaved image stream is selected to ensure viewers 40, 42, 44 can still interpret the image 34, 36, 38 displayed on the display media 25. For example, in the case of the three images 34, 36, 38 combined into the interleaved image stream 20, each frame 22a-c can be displayed for about 1/90 second. The filtering mechanism 50, 52, 54 for each viewer 40, 42, 44 is synchronized to pass the appropriate image frame 22a-c at the correct time for each viewer and to prevent image frames 22a-c from other ones of the image streams 14, 16, 18 from being seen. Polarizing filters combined with shutters can be used to double the effective frame rate.

Again, as with the number of image streams 14, 16, 18 interleaved, the number of viewers 40, 42, 44 illustrated in Fig. 1 should not be seen as limiting. Any number of viewers 40, 42, 44 may view each one of the image streams 14, 16, 18 contained in the interleaved image stream 20. Viewers 40, 42, 44 may all view the same filtered image 34, 36, 38, or they may each view a different one, and other, different image streams can be provided for additional viewers to view. Viewers 40, 42, 44 may view a common filtered image 34, 36, 38 through a shared filter mechanism 50, 52, or 54, or through individual filter mechanisms. Filter mechanisms 50, 52, 54 include, among

other things, self-supported panels or windows containing active shutters, and headwear, including goggles or glasses with active shutter lenses. Optionally, filter mechanisms 50, 52, 54 can be electro-optical systems or polarizing filters. It should be noted that the system does not require a given image 34, 36, 38 in the interleaved image stream 20 to be viewed by any viewer.

Referring now also to Fig. 2 illustrates an optional embodiment of the invention shown in Fig. 1 in which two image display drivers or projectors 85, 95 are provided and the outputs are combined on display media 25. The term projector is intended to include other image display devices used to produce an image upon a surface, including LCD and plasma monitors, among others. Projectors 85, 95 may be capable of displaying images at frame rates of 30 frames/sec and higher, including about 150 frames/ second or more.

In Fig. 2, the common image projector 95 receives a single image signal from source 90 for display on display media 25. The image signal from source 90 is not interleaved. All viewers in the system see the same image produced by projector 95. A multiple image projector 85 receives a signal containing multiple images from image multiplexer 80 for display on the display media 25 in combination or overlay with the image from common image projector 95. Image multiplexer 80 combines signals from three sources 64, 66, 70. Source 70 produces an image stream that is responsive to user inputs 60, 62. Sources 64, 66 are real time image generators which use inputs from interactive inputs 60, 62 to generate image displays to combine with the image stream from source 70 and produce an interleaved image stream 20. It will be understood that source 70 may be responsive to the sources 64, 66 in that various changes to a story line may occur based on one or more viewer's input. This optional feature is reflected in the connection illustrated in broken line between sources 64, 66 and source 70.

In order to display the images from projectors 85, 95 properly to viewers, the non-interleaved frame rate from common image projector 95 can be adjusted so that each frame is displayed for the same amount of time as one cycle of interleaved frames from the multiple image projector 85. That is, the image from common image

projector 95 is displayed for the same amount of time as it takes to display one frame for each of the interleaved image streams combined by the image multiplexer 80. When a viewer watches the combined images from the common image projector 95 and the multiple image projector through a filter mechanism 50, the viewer sees a selected image stream from the multiple image projector. It should be noted that in order for each viewer to see the correct combined image, the images from sources 64, 66, and 70 may be subtracted from the image source 90 sent to projector 95. That is, projector 95 presents the common background image with holes or blank space where the images from sources 64, 66, 70 are projected to produce the combined image. The image subtraction is necessary so that viewers do not see color-distorted images on display media 25.

As an example, the invention as illustrated by Fig. 2 can be used to provide an interactive experience in which a guest at an entertainment attraction provides the user input 60 or 62 to the system. The user input 60, 62 drives real-time image generator 64, 66 to produce an image stream that can be multiplexed and displayed. In one embodiment, the user inputs can be gaming guns for simulating targeting and shooting target objects in an image stream displayed on the display media 25. The image multiplexer 80 combines images of targets generated by the responsive source 70 with images corresponding to "shots" fired by the gaming guns (user inputs 60, 62). The multiplexed image stream combines the user input generated images 64, 66 with the responsive source image 70 into a single stream. As shown in Fig. 2, if there are two users each with one of the user inputs 60, 62, images corresponding to their shots can be interleaved in the multiplexed image stream, and the users can be outfitted with filter mechanisms 50, 52, 54 so that they each see only their own shots, even though they are playing on the same display media 25. The multiplexed image stream is projected or displayed by projector 85 concurrently with, for example, a background image generated from source 90 and projected or displayed by projector 95.

Referring again to Fig. 1, in a still further embodiment, the image streams 14, 16, 18 are composed of frames 14a-d, 16a-d, 18a-d that produce three-dimensional images. The frames are divided into left eye and right eye images as is known when creating

three-dimensional images; that is, one set of frames is intended to be seen by a viewer's left eye only, while the other set of frames are to be seen only by the viewer's right eye. The frames of each image stream 14, 16, 18 are arranged so that when they are interleaved, the corresponding left and right eye images for each viewer are displayed consecutively. Filter mechanisms 50, 52, 54 are provided to each viewer 40, 42, 44 which selectively expose only one of the viewer's eyes at a time in synchronization with the desired image stream so that each viewer sees a three-dimensional image. The filter mechanisms 50, 52, 54 may use polarization or electrical or mechanical shuttering or some combination thereof to block or pass a desired image.

Fig. 3 is a timing chart showing the status of a shutter L1, R1; L2, R2; L3, R3 for each lens of a viewer's filtering mechanism 50, 52, 54. In the timing chart, a "0" indicates the shutter is closed, while a "1" indicates the shutter is open. As can be seen, only one shutter L1, R1; L2, R2; L3, R3 of the six in the example is opened at any one time. The shutters L1, R1; L2, R2; L3, R3 are opened sequentially in the same order that the corresponding image stream frames are displayed. The opening of a selected shutter L1, R1; L2, R2; L3, R3 is synchronized to the corresponding image frame. For example, the first stream, left eye image is displayed at time 1 while shutter L1 is open, followed by the first stream, right eye image at time 2 while shutter R1 is open, then the second stream, left eye image is displayed at time 3 as shutter L2 is open, and so on. Alternatively, the left and right eye image frames for the image streams can be interleaved so that all left eye image frames are displayed, followed by all right eye image frames. Other image interleaving patterns are possible as well.

As indicated in Fig. 3, for three viewers, each shutter can be opened for about 1/180 second, during which time the corresponding image frame of the interleaved three-dimensional image stream is displayed on display media 25. In a three viewer system, such as diagrammed in Figs. 1 and 3, each viewer sees a filtered image in each eye for 1/180 second and each viewer's eye is exposed to a new image every 1/30 second, for a frame rate of 30 frames per second for each viewer.

In a further alternative, the three dimensional image streams could be used in the interactive system of Fig. 2. In such case the filters 50, 52, 54 are adapted to incorporate separate lenses with independent shutters L1, R1; L2, R2; L3, R3 for each eye of a viewer, and the shutters are operated as shown in Fig. 3. As a result, a three-dimensional image is seen by each viewer overlaid on a common or background image from source 90. A three-dimensional individual interactive experience is thereby provided using a single display media.

Figs. 4 and 5 illustrate further timing charts using different sequences for opening and closing the shutters L1, R1; L2, R2; L3, R3. As can be seen in Fig. 4, the shuttering order starts with the right shutter, R1 instead of the left shutter L1, and is then followed in sequence by R2 and R3. The left lenses L1, L2, L3 are then opened in order after the right lenses R1, R2, R3. In Fig. 5, the shutter opening starts with R3, followed by L3, then R2, L2 and R1, L1 in order. Thus, it should be clear that the only restriction on the order of operation of the shutters is simply that one side of a filter mechanism 50, 52, 54 should not shutter twice before the other side shutters once, so that each viewer's eye is exposed to coordinated images for a given frame.

While the present invention has been described with references to preferred embodiments, various changes or substitutions may be made on these embodiments by those ordinarily skilled in the art pertinent to the present invention without departing from the technical scope of the present invention. Therefore, the technical scope of the present invention encompasses not only those embodiments described above, but all that fall within the scope of the appended claims.

What is Claimed is:

1. A method of displaying multiple image streams each comprising multiple image frames for entertaining multiple viewers, comprising:

generating at least three separate image streams comprising multiple image frames and providing for input from at least one viewer to at least one of the separate image streams;

interleaving image frames of each image stream to produce an interleaved image stream; and

displaying the interleaved image stream.

2. The method of claim 1, wherein the interleaving of each image frame is sequential.

3. The method of claim 1, further comprising filtering the displayed interleaved image stream to separate one of the image streams for viewing by one of the viewers.

4. The method of claim 3, wherein the interleaved image stream comprises an interleaved image stream configured for displaying two-dimensional images.

5. The method of claim 3, wherein the interleaved image stream comprises an interleaved image stream configured for displaying three-dimensional images.

6. The method of claim 3, wherein filtering the displayed interleaved image stream comprises providing polarized lenses.

7. The method of claim 1, further comprising generating a background image and displaying the background image along with the interleaved image stream.

8. The method of claim 7, wherein the interleaved image stream is subtracted from the background image prior to displaying the background image and the interleaved image stream.

9. The method of claim 1, wherein providing for input from at least one viewer comprises providing a responsive image source for varying at least one story line based on input at least one of the viewers.

10. The method of claim 3, wherein filtering the displayed interleaved image stream comprises providing a plurality of shutters that open and close for a predetermined period of time that is synchronized with a frame rate of the interleaved image stream.

11. The method of claim 10, wherein each shutter is open for about 1/180 second and the frame rate is approximately thirty frames per second.

12. The method of claim 1, wherein displaying the interleaved image stream comprises providing a plurality of image projectors one of which projects a background image stream.

13. A device for displaying multiple image streams each comprising multiple image frames that entertains multiple viewers, comprising:

at least three image generators for generating at least three separate image streams each comprising multiple image frames and wherein at least one image generator is configured for at least one viewer input;

an image multiplexer for interleaving image frames of each image stream to produce an interleaved image stream; and

a display for showing the interleaved image stream.

14. The device of claim 13, further comprising at least one filter for filtering the displayed interleaved image stream to separate one of the image streams for viewing by one of the viewers.

15. The device of claim 14, wherein the at least one filter comprises polarized lenses.

16. The device of claim 13, further comprising a background image source that generates a background image for display with the interleaved image stream.

17. The device of claim 16, wherein the interleaved image stream is subtracted from the background image prior to the background image being displayed with the interleaved image stream.

18. The device of claim 13, wherein the display comprises a plurality of image projectors one of which projects a background image stream.

19. The device of claim 13, wherein the at least one image generator configured for at least one viewer input comprises a responsive image source connected to a plurality of image generators each being configured for varying at least one story line based on input from each viewer.

20. The device of claim 14, wherein the at least one filter comprises providing a plurality of shutters that open and close for predetermined period of time that is synchronized with a frame rate of the interleaved image stream.

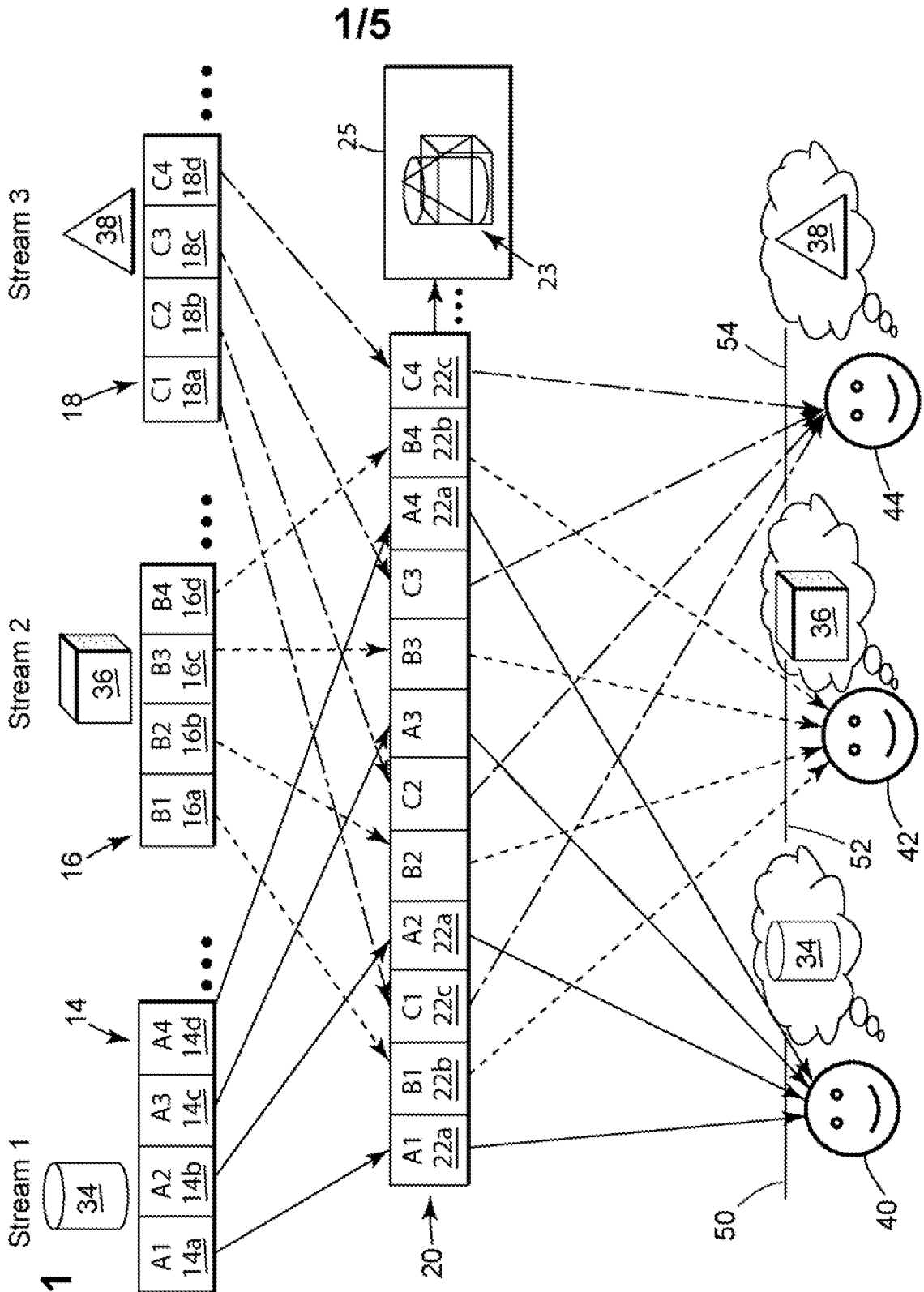
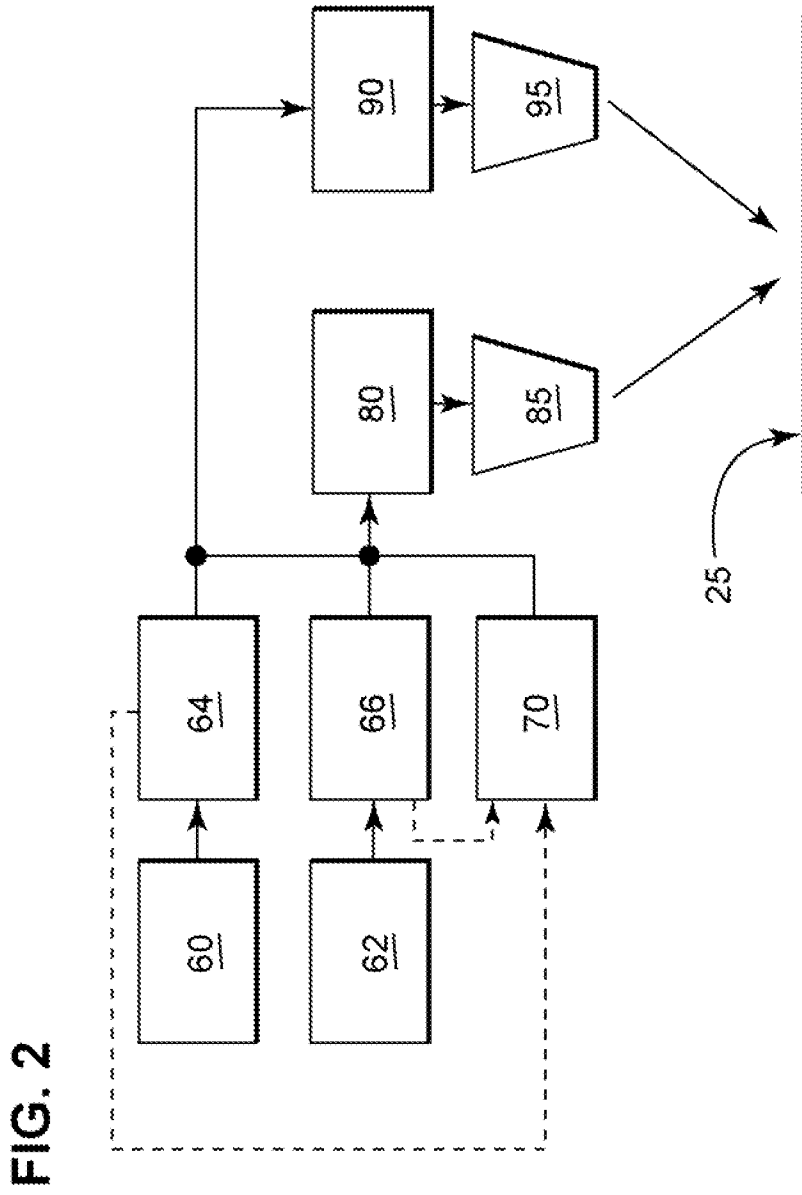

FIG. 1

2/5



3/5

FIG. 3

Time (1/180 sec)	L1	R1	L2	R2	L3	R3
1	1	0	0	0	0	0
2	0	1	0	0	0	0
3	0	0	1	0	0	0
4	0	0	0	1	0	0
5	0	0	0	0	1	0
6	0	0	0	0	0	1
7	1	0	0	0	0	0
8	0	1	0	0	0	0
9	0	0	1	0	0	0
10	0	0	0	1	0	0
11	0	0	0	0	1	0
12	0	0	0	0	0	1
13	1	0	0	0	0	0
14	0	1	0	0	0	0
15	0	0	1	0	0	0
16	0	0	0	1	0	0
17	0	0	0	0	1	0
18	0	0	0	0	0	1
19	1	0	0	0	0	0
20	0	1	0	0	0	0

4/5

FIG. 4

Time (1/180 sec)	L1	R1	L2	R2	L3	R3
1	0	1	0	0	0	0
2	0	0	0	1	0	0
3	0	0	0	0	0	1
4	1	0	0	0	0	0
5	0	0	1	0	0	0
6	0	0	0	0	1	0
7	0	1	0	0	0	0
8	0	0	0	1	0	0
9	0	0	0	0	0	1
10	1	0	0	0	0	0
11	0	0	1	0	0	0
12	0	0	0	0	1	0
13	0	1	0	0	0	0
14	0	0	0	0	0	0
15	0	0	1	0	0	1
16	1	0	0	0	0	0
17	0	0	1	0	0	0
18	0	0	0	0	1	0
19	0	1	0	0	0	0
20	0	0	0	1	0	0

5/5**FIG. 5**

Time (1/180 sec)	L1	R1	L2	R2	L3	R3
1	0	0	0	0	0	1
2	0	0	0	0	1	0
3	0	1	0	0	0	0
4	1	0	0	0	0	0
5	0	0	0	1	0	0
6	0	0	1	0	0	0
7	0	0	0	0	0	1
8	0	0	0	0	1	0
9	0	1	0	0	0	0
10	1	0	0	0	0	0
11	0	0	0	1	0	0
12	0	0	1	0	0	0
13	0	1	0	0	0	1
14	0	0	0	0	1	0
15	0	1	0	0	0	0
16	1	0	0	0	0	0
17	0	0	0	1	0	0
18	0	0	1	0	0	0
19	0	0	0	0	0	1
20	0	0	0	0	1	0

INTERNATIONAL SEARCH REPORT

International application No
PCT/US2007/069458

A. CLASSIFICATION OF SUBJECT MATTER INV. H04N13/04		
According to International Patent Classification (IPC) or to both national classification and IPC		
B. FIELDS SEARCHED		
Minimum documentation searched (classification system followed by classification symbols) H04N		
Documentation searched other than minimum documentation to the extent that such documents are included in the fields searched		
Electronic data base consulted during the international search (name of data base and, where practical, search terms used) EPO-Internal		
C. DOCUMENTS CONSIDERED TO BE RELEVANT		
Category*	Citation of document, with indication, where appropriate, of the relevant passages	Relevant to claim No.
X	US 2004/056948 A1 (GIBSON ROBERT JOHN [US]) 25 March 2004 (2004-03-25) the whole document	1-5,7, 9-11, 13-15, 19,20
X	US 6 188 442 B1 (NARAYANASWAMI CHANDRASEKHAR [US]) 13 February 2001 (2001-02-13) column 3, line 25 - column 4, line 49; figures 1,2 ----- <div style="text-align: center;">-/--</div>	1-4,6, 10,11, 13-15,20
<div style="display: flex; justify-content: space-between;"> <input checked="" type="checkbox"/> Further documents are listed in the continuation of Box C. <input checked="" type="checkbox"/> See patent family annex. </div>		
* Special categories of cited documents :		
A document defining the general state of the art which is not considered to be of particular relevance *E* earlier document but published on or after the international filing date *L* document which may throw doubts on priority claim(s) or which is cited to establish the publication date of another citation or other special reason (as specified) *O* document referring to an oral disclosure, use, exhibition or other means *P* document published prior to the international filing date but later than the priority date claimed	*T* later document published after the international filing date or priority date and not in conflict with the application but cited to understand the principle or theory underlying the invention *X* document of particular relevance; the claimed invention cannot be considered novel or cannot be considered to involve an inventive step when the document is taken alone *Y* document of particular relevance; the claimed invention cannot be considered to involve an inventive step when the document is combined with one or more other such documents, such combination being obvious to a person skilled in the art. *&* document member of the same patent family	
Date of the actual completion of the international search <div style="text-align: center; font-weight: bold;">6 November 2007</div>	Date of mailing of the international search report <div style="text-align: center; font-weight: bold;">14/11/2007</div>	
Name and mailing address of the ISA/ European Patent Office, P.B. 5818 Patentlaan 2 NL - 2280 HV Rijswijk Tel. (+31-70) 340-2040, Tx. 31 651 epo nl, Fax: (+31-70) 340-3016	Authorized officer <div style="text-align: center; font-weight: bold;">Mao, Pauline</div>	

INTERNATIONAL SEARCH REPORT

International application No

PCT/US2007/069458

C(Continuation). DOCUMENTS CONSIDERED TO BE RELEVANT		
Category*	Citation of document, with indication, where appropriate, of the relevant passages	Relevant to claim No.
X	<p>US 2002/105483 A1 (YAMAZAKI SHUNPEI [JP] ET AL) 8 August 2002 (2002-08-08)</p> <p>paragraph [0002] figures 1-4 figures 7,13A,13B figures 20,21 figures 22,23</p>	<p>1-6, 9-11, 13-15, 19,20</p>
X	<p>US 4 562 463 A (LIPTON LENNY [US]) 31 December 1985 (1985-12-31)</p> <p>column 7, lines 18-26 column 18, lines 2-20 column 18, lines 20-22</p>	<p>1-6, 9-11, 13-15, 19,20</p>
A	<p>US 6 529 209 B1 (DUNN JAMES M [US] ET AL) 4 March 2003 (2003-03-04) abstract</p>	<p>1-20</p>

INTERNATIONAL SEARCH REPORT

Information on patent family members

International application No
PCT/US2007/069458

Patent document cited in search report	Publication date	Patent family member(s)	Publication date
US 2004056948	A1	25-03-2004	NONE
US 6188442	B1	13-02-2001	NONE
US 2002105483	A1	08-08-2002	NONE
US 4562463	A	31-12-1985	NONE
US 6529209	B1	04-03-2003	CN 1304131 A 18-07-2001
			GB 2360414 A 19-09-2001
			JP 2001255844 A 21-09-2001
			KR 20010070492 A 25-07-2001
			US 2003133569 A1 17-07-2003