

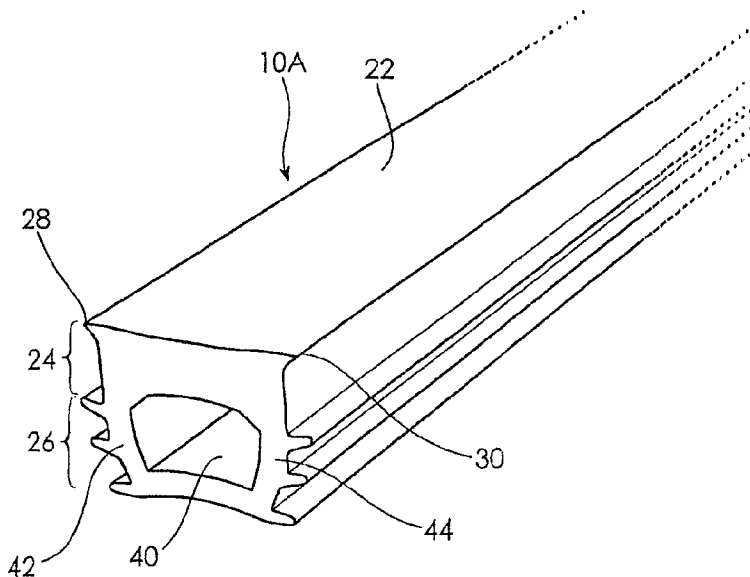

(22) Date de dépôt/Filing Date: 2017/03/09
(41) Mise à la disp. pub./Open to Public Insp.: 2018/09/06
(45) Date de délivrance/Issue Date: 2021/03/23
(30) Priorité/Priority: 2017/03/06 (AU2017201530)

(51) Cl.Int./Int.Cl. *E04B 1/682* (2006.01),
E04B 1/68 (2006.01), *E04G 23/02* (2006.01),
F16J 15/02 (2006.01), *F16J 15/14* (2006.01)
(72) Inventeurs/Inventors:
TUYNMAN, HENDRIK, AU;
TUYNMAN, KAREL, AU;
ASADABADI, AMIR, AU
(73) Propriétaire/Owner:
JEHBCO SILICONE SPECIALISTS, AU
(74) Agent: AVENTUM IP LAW LLP

(54) Titre : UN JOINT ET UNE METHODE D'ETANCHEISATION D'ESPACEMENTS ET DE JOINTS
(54) Title: A SEAL AND GAPS AND JOINTS SEALING METHOD



(57) **Abrégé/Abstract:**

The present invention relates to a resilient seal for sealing one or more gaps or joints. The seal includes an elongate strip having first and second portions. The first portion is adapted in use to engage one or more internal surfaces defining the gaps or joints. The second portion is adapted to substantially conform to the shape and configuration of the or each gap or joint so as to substantially fill the or each gap or joint when in use. The invention also relates to a method of sealing one or more gaps or joints using the resilient seal.

Abstract

The present invention relates to a resilient seal for sealing one or more gaps or joints. The seal includes an elongate strip having first and second portions. The first portion is adapted in use to engage one or more internal surfaces defining the gaps or joints. The
5 second portion is adapted to substantially conform to the shape and configuration of the or each gap or joint so as to substantially fill the or each gap or joint when in use. The invention also relates to a method of sealing one or more gaps or joints using the resilient seal.

A Seal and Gaps and Joints Sealing Method

Technical Field

The present invention generally relates to seals. More particularly, the present invention relates to seals for use in façade gaps and expansion joints. The present invention also
5 relates to a method of sealing façade gaps and expansion joints.

Background of the Invention

External cladding systems are commonly used for contemporary new and refurbishment building projects. One of the most popular and versatile cladding systems is generally referred to as a cassette panel system suitable for application on low to high rise
10 buildings. In such a system, multiple cassettes are bent and fixed with invisible clips to a framework which is secured to the load bearing structure. It offers a façade solution that provides a modern appearance. Typically, the cassettes are installed onto a load bearing structure with staggered angle clips creating gaps and joints between adjacent cassettes. These gaps and joints are conventionally sealed with liquid sealants such as caulk in order
15 to stop water penetration and form a smooth surface. Such a wet-seal system requires a 'backing rod filling technique' relying on the set liquid sealant as a defence against water and moisture penetration. This wet-seal system has at least the following shortcomings:

- (i) it is time-consuming and costly to apply;
- (ii) it is cumbersome to apply and may not function well when the gaps are too
20 wide;
- (iii) it may have problems relating to bubbling and unevenness of the surface of the seal which are aesthetically unpleasant;
- (iv) the seal may bulge out of the surface as a result of the expanding and shrinking of the gap due to change of weather;
- 25 (v) it unavoidably involves wastage which incurs disposal and transportation costs of cartridges;
- (vi) it is susceptible to hot weather - when poured into an expansion joint, the wet silicone boils leading to both aesthetic and performance issues.

It is an object of the present invention to provide a seal and a gap or joint sealing method which may ameliorate the abovementioned shortcoming or which will at least provide the public with a useful choice.

Summary of the Invention

5 According to one aspect of the present invention, there is provided a resilient seal for sealing one or more gaps or joints, the seal including an elongate strip having first and second portions, the first portion adapted in use to engage one or more internal surfaces defining the gaps or joints, the second portion being adapted to substantially conform to the shape and configuration of the or each gap or joint so as to substantially fill the or
10 each gap or joint when in use.

In a preferred embodiment, the resilient seal includes a hollow running longitudinally along the length of the strip. Preferably, the hollow is located at least partially in the second portion of the elongate strip. More preferably, the hollow is positioned, shaped and configured so as to facilitate elastic deformation of part or all of the second portion as it
15 enters the or each gap or joint.

In a preferred embodiment, the hollow is at least defined by two side walls forming part of the second portion. During installation, when subjected to external compressing or squeezing forces, the side walls are preferred to collapse inwardly so as to facilitate placement of the elongate strip into the or each gap. The hollow has a cross section which
20 may be substantially cylindrical, trapezoidal or irregular in shape.

Preferably, the first portion has a width that is smaller than that of an opening of the or each gap or joint. As such, once forced into place within the or each gap or joint, the first portion naturally urges onto the internal surfaces of the or each gap or joint thereby providing a tight seal. More preferably, the first portion includes one or more extensions
25 adapted to ensure a smooth and continuous transition.

Preferably, the one or more extensions when in use are located at or near an opening of the or each gap or joint. More preferably, the first portion is flanked by a pair of extensions, each extension being in the form of a flange. The extensions are preferred to be configured so as to seamlessly conceal the or each gap or joint.

Preferably, the second portion includes gripping means. The gripping means may include one or more elements of the second portion. More preferably, the or each element is prominent in shape including an obtuse corner, an acute corner, a pointy end and a flange. Even more preferably, the gripping means include one or more pairs of flanges.

- 5 Even more preferably, the second portion is flanked by three pairs of flanges extending outwardly from the two side walls of the second portion and being adapted to engage the internal surfaces of the or each gap or joint. Even more preferably, each flange is disposed at an inclined angle to the corresponding side wall so as to facilitate entrance into the corresponding gap or joint during installation.
- 10 Optionally, the resilient seal includes one or more branches. Each branch may extend laterally or in any other chosen direction. Preferably, the resilient seal includes two branches extending laterally from the elongate strip thereby forming a cross-shaped cross section. More preferably, each branch includes an elongate hollow which may or may not be in communication with the hollow of the elongate strip.
- 15 In an alternative embodiment, the strip is solid having a U-shaped cross section.

Preferably, the seal is made of a resilient material. More preferably, the resilient material is silicone.

Preferably, the elongate strip is an extrusion.

Preferably, the joints include expansion joints.

- 20 According to another aspect of the present invention, there is provided a method of sealing one or more gaps or joints, the method including the steps of:

- (a) providing a resilient seal adapted to fill the or each gap or joint;
 (b) aligning the resilient seal with the or each gap or joint; and
 25 (c) pushing or forcing the resilient seal into the or each gap or joint.

Preferably, the method includes an initial step of applying a layer of adhesive onto at least part of the internal surfaces of the or each gap or joint.

Preferably, the or each seal includes an elongate strip having first and second portions, the first portion having one or more extensions adapted in use to engage one or more internal surfaces defining the gaps or joints, the second portion being adapted to substantially conform to the shape and configuration of the or each gap or joint so as to substantially fill the or each gap or joint when in use.

The resilient seal may be forced into the or each gap or joint by utilising a roller.

The resilient seal is preferred to be made of silicone.

According to one aspect of the invention, there is provided a resilient seal for sealing one or more gaps or joints, the seal comprising:

10

an elongate strip having a first portion and a second portion integrally formed with the first portion, the second portion having two opposing side walls each having a longitudinal axis extending away from the first portion, the second portion having a bottom wall extending between and connecting a distal end of each of the two opposing side walls,

15

a hollow running longitudinally along the length of the strip and located at least partially in the second portion of the elongate strip, and

20

a pair of opposing extensions located at an exposed surface of the first portion, wherein:

25

the pair of opposing extensions define a width of the exposed surface that is greater than a width of the first portion lacking the pair of opposing extensions,

the exposed surface of the first portion is spaced apart from the second portion and, based in part upon the pair of opposing extensions,

provides a flush surface relative to a top of the gaps or joints,

30

the first portion, in use, engages one or more internal surfaces defining the gaps or joints,

the second portion substantially conforms to the shape and configuration of the or each gap or joint so as to, in use, substantially fill the or each gap or joint;

5 the second portion is flanked by at least one pair of flanges extending outwardly from the two opposing side walls of the second portion, each flange of the at least one pair of flanges having a longitudinal axis extending at an acute angle relative to the longitudinal wall axis of the second portion such that each flange engages the internal surfaces of the gaps or joints;

10 the bottom wall has at least one exterior-facing concave surface extending between the distal end of each of the two opposing side walls; and

the hollow is defined by:

15 a concave upper surface positioned between the first portion and an uppermost of the at least one pair of flanges of the second portion,

20 a convex lower surface extending substantially parallel with the concave upper surface and being defined by a portion of the bottom wall,

a pair of chamfered surfaces extending at an acute angle relative to and from opposing ends of the concave upper surface, and

25 a pair of side surfaces extending from the pair of chamfered surfaces to the convex lower surface, the pair of side surfaces of 5 the hollow being defined by an interior-facing surface of the two opposing side walls of the second portion.

30

35

Brief Description of the Drawings

The invention in its various aspects will now be described in connection with non-limiting embodiments illustrated in the accompanying drawings. It will be appreciated that the drawings are not all shown on the same scale.

5 Figure 1 is a perspective view of a first embodiment of the resilient seal being installed into a gap between cassettes of a façade of a building;

 Figure 2 is a perspective view of the seal of Figure 1;

 Figure 3 is an end view of the seal of Figure 1;

10 Figure 4 is a cross-sectional view of the seal of Figure 1 after installation into a gap;

 Figure 5 is a perspective view of a second embodiment of the resilient seal;

 Figure 6 is an end view of the seal of Figure 5;

 Figure 7 is a cross-sectional view of the seal of Figure 5 after installation into a gap;

15 Figure 8 a perspective view of a third embodiment of the resilient seal;

 Figure 9 is an end view of the seal of Figure 8;

 Figure 10 is a cross-sectional view of the seal of Figure 8 after installation into a gap;

Figure 11 is a perspective view of a fourth embodiment of the resilient seal;

Figure 12 is an end view of the seal of Figure 11;

Figure 13 is a cross-sectional view of the seal of Figure 11 after installation into a gap;

5 Figure 14 is a perspective view of a fifth embodiment of the resilient seal;

Figure 15 is a plan view of the seal of Figure 14 installed in a four-way joint.

Detailed Description of the Drawings

It should be noted that the resilient seals described herein are intended to be applied to fill cassette façade gaps or expansion joints for example. It will however be appreciated that
 10 the resilient seals may be used to fill gaps or joints (eg. expansion joints) created by other building materials such as windows and glazing or even concrete. Various embodiments of resilient seals of the present invention are herein described to be applied to fill cassette façade gaps for exemplary purposes. Also, the seals of the present invention are made of a resilient material such as silicone by way of solid extrusion. Furthermore, the elongate
 15 strip of each seal is manufactured by extrusion.

Referring to Figure 1 and 4, a resilient seal 10A is shown being applied by way of a roller 20 to fill a gap 12 between cassettes 14 & 16 of a façade 18 of a building. As shown in Figures 2 to 4, the resilient seal has an elongate strip 22 having first (front) and (rear) second portions 24 & 26. The first portion 24 has a width that is smaller than that of an
 20 opening of the gap 12. As such, once forced into place within the gap 12, the first portion 24 naturally urges onto internal surfaces 34 & 36 of the gap 12 thereby providing a tight seal. Also, the first portion 24 is flanked by extensions which are in the form of a pair of flanges 28 & 30. The extensions function to ensure a smooth and continuous transition from the cassettes 14 & 16 to the seal 10A.

25 As best shown in Figure 4, once the seal 10A is installed, the flanges 28 & 30 are located at or near an opening 32 of the gap 12. The flanges 28 and 30 in use are in tight engagement with the respective internal surfaces 34 & 36 which partially define the gap 12 and a waterproofing seal is achieved as a result. The exposed surface 38 is flush with faces of the cassettes 14 & 16. As such, the flanges 28 & 30 are effective in seamlessly
 30 concealing the gap 12. The second portion 26 is configured to substantially conform to the

shape and configuration of the gap 12. As such, the second portion 26 is snugly received within the gap 12 thereby substantially filling up space defined by the internal surfaces 34 & 36.

Referring to 2 to 4, the resilient seal 10A has a hollow 40 running longitudinally along the length of the strip 22. In the present embodiment, the hollow 40 is located in the second portion 26 of the elongate strip 22 being defined by two side walls 42 & 44 which form part of the second portion 26. The hollow 40 is positioned, shaped and configured so as to facilitate elastic deformation of at least the side walls 42 & 44 of the second portion 26 as it enters the gap 12. During installation, when subjected to external compressing or squeezing forces, the side walls 42 & 44 are designed to resiliently collapse inwardly in order to facilitate placement of the elongate strip 22 into the gap 12. In the present embodiment, the cross section of the hollow 40 is in the shape of a wonky trapezium.

The second portion 26 of the elongate strip 22 has gripping means being one or more elements of the second portion 26. In a general sense, each element is prominent in shape including an obtuse corner, an acute corner, a pointy end and a flange. In the present embodiment, the second portion is flanked by gripping means being three pairs of flanges 46 extending outwardly from the two side walls 42 & 44 of the second portion 26. The flanges 46 are configured to engage the rear end of internal surfaces 34 & 36 of the gap 12. As best shown in Figure 3, each of the flanges 46 is disposed at an inclined angle to the corresponding side wall 42, 44 so as to facilitate entrance into the gap 12 during installation.

Turning to Figures 5 to 7, another embodiment of the resilient seal 10B is shown. Seal 10B is similar to seal 10A in terms of their shape and configuration, except that seal 10B has a relatively taller first portion 48 and a narrower overall width 50. Seal 10B is shown to illustrate that seals of a similar shape and configuration may be made in different dimensions to suit different gaps. Seal 10B also has a symmetrical hollow 51 partially defined by side walls 53 & 55 which are configured to cover the depth of the gap 57. The hollow 51 has a cross section with a square base and a tapering top.

Referring to Figures 8 to 10, a further embodiment of the resilient seal 10C is shown. The seal 10C is shaped and configured to conform to the substantially triangular shape of the gap 56 (see Figure 10). Seal 10C has a rather shallow first portion 52 and a second

portion 54 which is in the shape of a wonky arrow. In this embodiment, the second portion 54 has gripping means that are in the form of an obtuse corner 58, an acute corner 60 and a pointy end 62. As shown in Figure 10, each of these gripping means are in use in firm engagement with slanting internal surfaces 62 & 64 of the gap 56. Also, the seal 10C has
 5 a hollow 66 with an oblong-shaped cross section.

As shown in Figures 11 to 13, a yet further embodiment of the seal 10D is shown. Seal 10D has a solid elongate strip with a U-shaped cross section. Seal 10D has a first portion with extensions in the form of flanges 72 and a second portion having gripping means in the form of obtuse corners 68 & 70 and a relatively blunt end 74. Referring to Figure 13,
 10 after installation, the obtuse corners 68 & 70 and blunt end 74 are in firm contact with the internal surface 76 of the gap 78.

Turning to Figures 14 and 15, a yet further embodiment of the seal 10E is shown. In addition to the elongate strip 80, Seal 10E has two branches 82 & 84 extending laterally thereby forming a cross-shaped cross section. Seal 10E is configured to be applied to a
 15 four-way joint such as that shown in Figure 15. The remainder of each of the elongate gaps 88, 90, 92 & 94 is filled and sealed with seal 10B. It is contemplated that in other embodiments, each branch may extend in any other chosen directions. Also, each branch may have an elongate hollow which may or may not be in communication with the hollow of the elongate strip 80 for example.

20 Referring to Figure 1, the method of sealing a cassette facade gap 12 is now described. The method includes the initial step of applying a layer of adhesive such as wet silicone onto at least part of the internal surfaces of the gap 12. It is however contemplated that this step is optional in that the seals of the present invention would still function well without any wet adhesive. A resilient seal 10A adapted to fill the gap 12 is then provided
 25 and aligned with the gap 12. The seal 10A is then pushed into the gap 12 and firmly forced into the gap 12 by way of a tool such as roller 20.

Now that preferred embodiments of the present invention have been described in some detail, it will be apparent to a skilled person in the art that the seals of the present invention may offer at least the following advantages:

- 30 (i) easy to apply, handle and install;
 (ii) it is unaffected by the ambient temperature;

- (iii) it enables full control over the shape of the seal profile thereby minimising wastage;
 - (iv) it's appearance after installation is not dependent on the skill and experience of the user during application;
 - 5 (v) it offers the user control throughout the application or installation process;
 - (vi) it offers consistency in terms of appearance after installation;
 - (vii) it offers longevity in terms of life expectancy; and
 - (viii) it can be made in different colours as desired to match different neighbouring materials or structure.
- 10 Those skilled in the art will appreciate that the invention described herein is susceptible to variations and modifications other than those specifically described. For instance, elongate strips in other shapes and configurations may be created to suit gaps of different sizes and configurations. Also, the hollow may be provided in different shapes and configurations depending on the size and configuration of the opening of a gap.
- 15 Furthermore, the seals of the present invention may be manufactured by other methods. All such variations and modifications are to be considered within the scope of the present invention the nature of which is to be determined from the foregoing description.

CLAIMS:

1. A resilient seal for sealing one or more gaps or joints, the seal comprising:
an elongate strip having a first portion and a second portion integrally formed with
5 the first portion, the second portion having two opposing side walls each having a
longitudinal axis extending away from the first portion, the second portion having a bottom
wall extending between and connecting a distal end of each of the two opposing side walls,
a hollow running longitudinally along the length of the strip and located at least
partially in the second portion of the elongate strip, and
10 a pair of opposing extensions located at an exposed surface of the first
portion, wherein:
the pair of opposing extensions define a width of the exposed surface that is
greater than a width of the first portion lacking the pair of opposing extensions,
the exposed surface of the first portion is spaced apart from the second
15 portion and, based in part upon the pair of opposing extensions,
provides a flush surface relative to a top of the gaps or joints,
the first portion, in use, engages one or more internal surfaces
defining the gaps or joints,
the second portion substantially conforms to the shape and
20 configuration of the or each gap or joint so as to, in use, substantially fill the or each
gap or joint;
the second portion is flanked by at least one pair of flanges extending
outwardly from the two opposing side walls of the second portion, each flange of the
at least one pair of flanges having a longitudinal axis extending at an acute angle
25 relative to the longitudinal wall axis of the second portion such that each flange
engages the internal surfaces of the gaps or joints;
the bottom wall has at least one exterior-facing concave surface extending
between the distal end of each of the two opposing side walls; and
the hollow is defined by:
30 a concave upper surface positioned between the first portion and an
uppermost of the at least one pair of flanges of the second portion,
a convex lower surface extending substantially parallel with the
concave upper surface and being defined by a portion of the bottom wall,

a pair of chamfered surfaces extending at an acute angle relative to
and

from opposing ends of the concave upper surface, and

5 a pair of side surfaces extending from the pair of chamfered surfaces
to the convex lower surface, the pair of side surfaces of 5 the hollow being
defined by an interior-facing surface of the two opposing side walls of the
second portion.

10 2. The resilient seal of claim 1, wherein the hollow is positioned, shaped and configured
so as to facilitate elastic deformation of part or all of the second portion as it enters the one
or more gaps or joints.

15 3. The resilient seal of claim 1, wherein, when subjected to external compressing or
squeezing forces, the side walls collapse inwardly so as to facilitate placement of the
elongate strip into the or each gap during installation.

4. The resilient seal of claim 1, wherein the hollow has a cross section that is at least one
of substantially cylindrical, trapezoidal and irregular in shape.

20 5. The resilient seal of claim 1, wherein the width of the first portion is smaller than that
of an opening of the one or more gaps or joints.

25 6. The resilient seal of claim 1, wherein the one or more extensions when in use are
located at or near an opening of the one or more gaps or joints.

7. The resilient seal of claim 1, wherein the pair of opposing extensions each comprise
an outwardly extending flange.

30 8. The resilient seal of claim 1, wherein the pair of opposing extensions are adapted to
seamlessly conceal the one or more gaps or joints.

9. The resilient seal of claim 1, wherein the at least one pair of flanges are prominent in
shape comprising an obtuse corner, an acute corner, and a pointy end.

10. The resilient seal of claim 1, wherein the at least one pair of flanges comprises three pairs of flanges extending outwardly from the two side walls of the second portion and engages the internal surfaces of the or each gap or joint.
- 5
11. The resilient seal of claim 1, wherein the at least one pair of flanges comprises three pairs of flanges extending outwardly from the two side walls of the second portion and being configured to engage the internal surfaces of the or each gap or joint.
- 10
12. The resilient seal of claim 11, wherein each flange in the three pairs of flanges flanking the second portion is disposed at an inclined angle to the corresponding side wall so as to facilitate entrance into the corresponding gap or joint during installation.
13. The resilient seal of claim 1, further comprising one or more branches.
- 15
14. The resilient seal of claim 13, wherein each of the one or more branches extends laterally or in any other chosen direction.
15. The resilient seal of claim 1, wherein the resilient seal comprises two branches extending laterally from the elongate strip thereby forming a cross-shaped cross section.
- 20
16. The resilient seal of claim 13, wherein each of the one or more branches includes an elongate hollow in communication with the hollow of the elongate strip.
- 25
17. The resilient seal of claim 1, wherein the strip is solid and has a U-shaped cross section.
18. The resilient seal of claim 1, wherein the seal is made of silicone.
- 30
19. The resilient seal of claim 1, wherein the elongate strip is an extrusion.
20. The resilient seal of claim 1, wherein the joints include expansion joints.

21. A method of sealing one or more gaps or joints, the method comprising the steps of:
- (a) providing the resilient seal of claim 1 to fill the or each gap or joint;
 - (b) aligning the resilient seal with the or each gap or joint; and
 - (c) pushing or forcing the resilient seal into the or each gap or joint.

5

22. The method of claim 21, further comprising an initial step of applying a layer of adhesive onto at least part of internal surfaces of the one or more gaps or joints.

10 23. The method of claim 21, wherein the resilient seal is forced into the one or more gaps or joints by utilizing a roller.

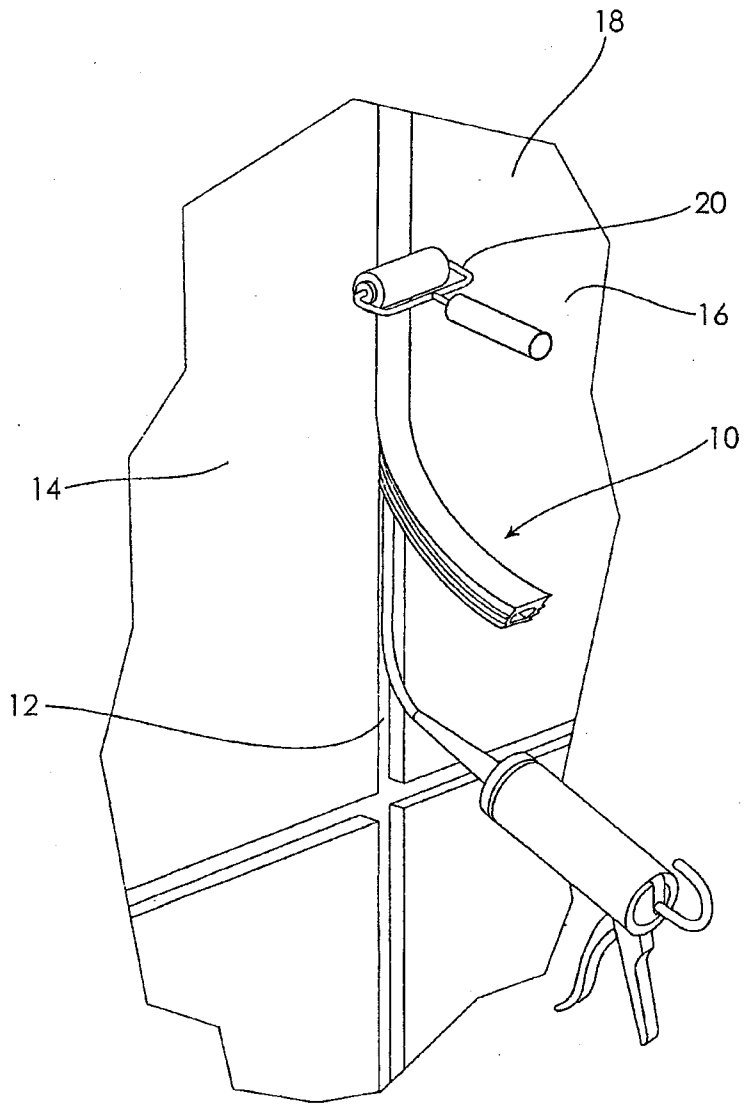
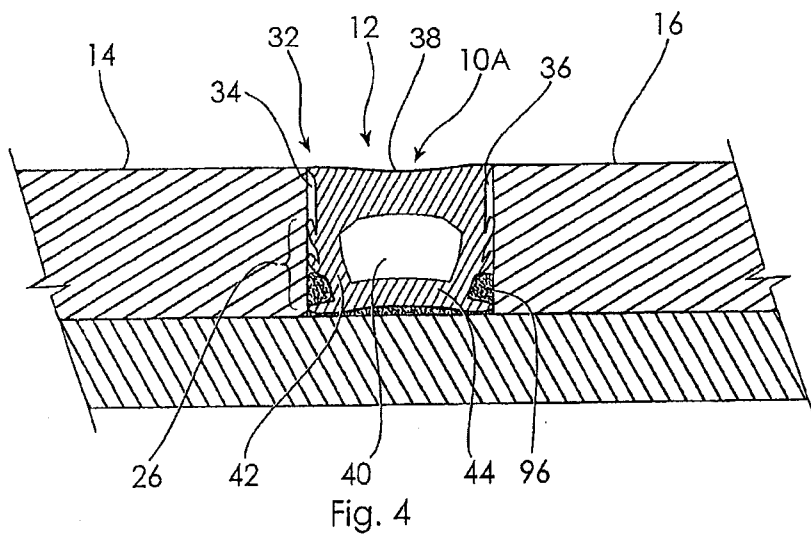
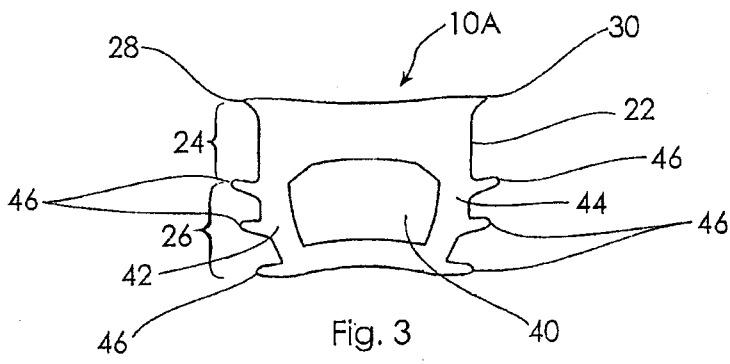
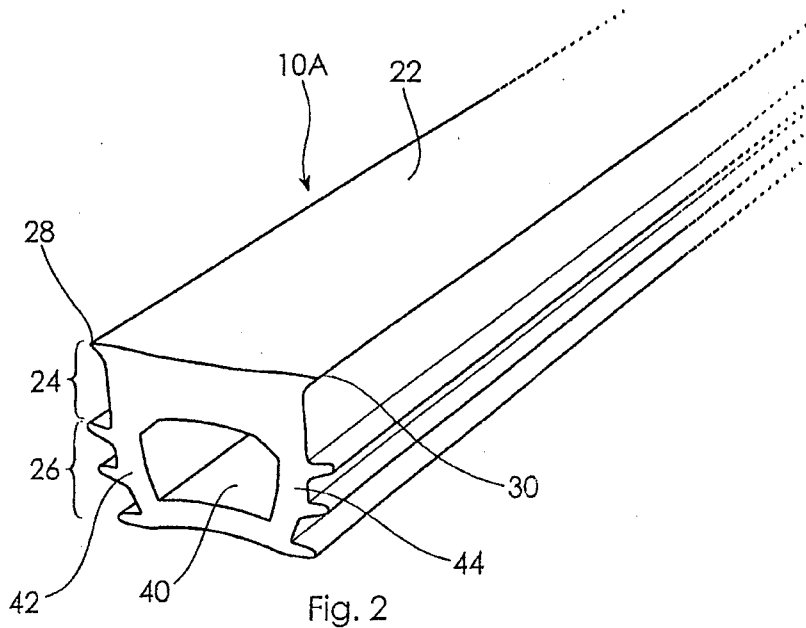

Fig. 1



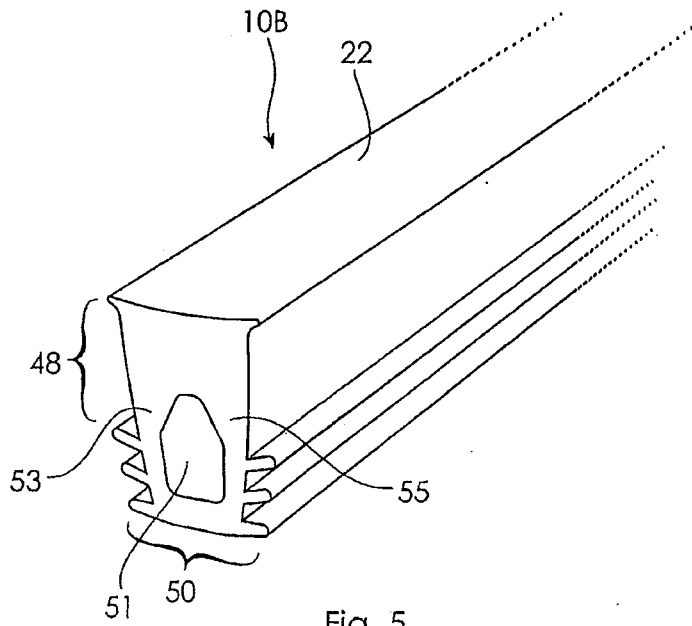

Fig. 5

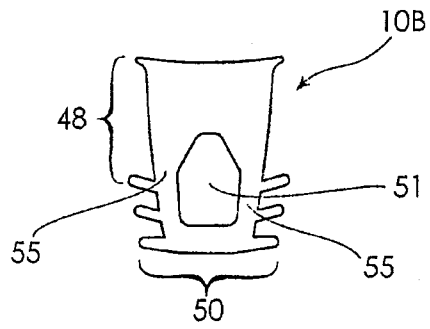

Fig. 6

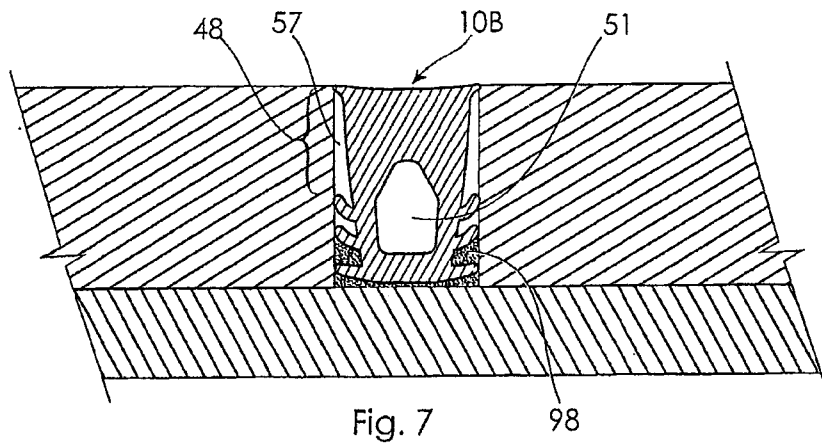
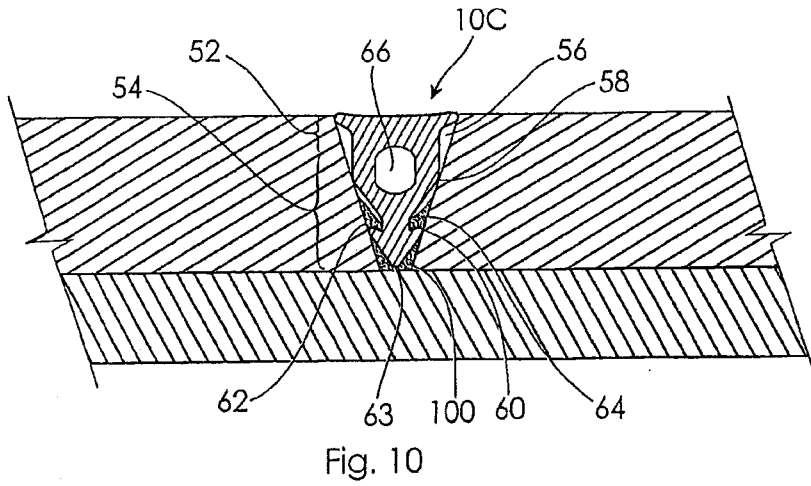
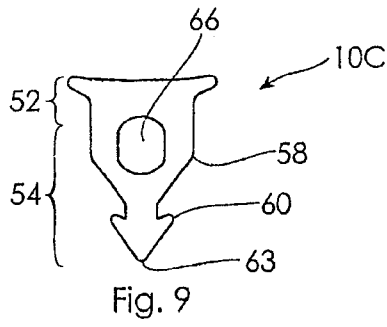
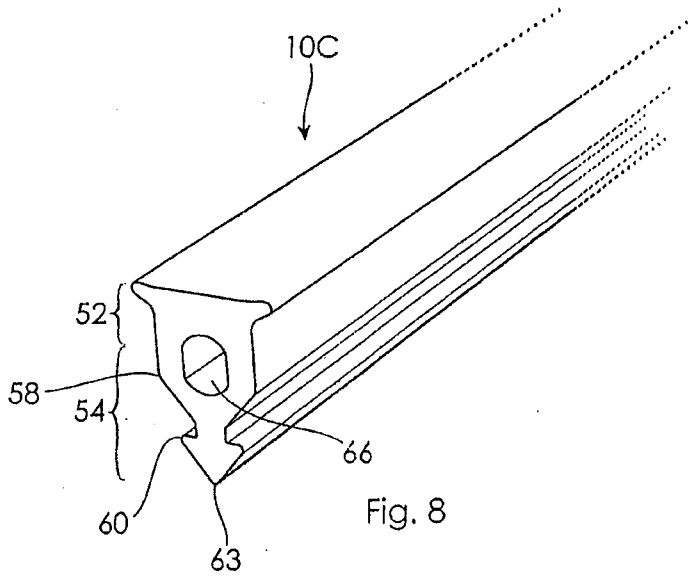

Fig. 7



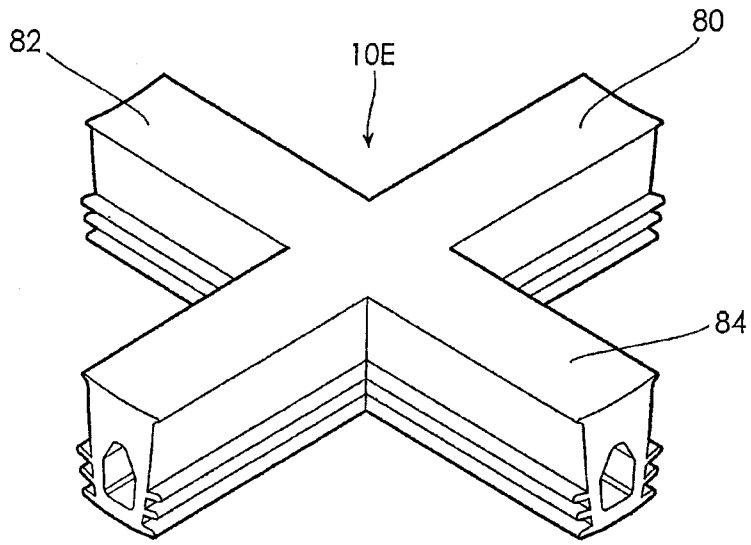

Fig. 14

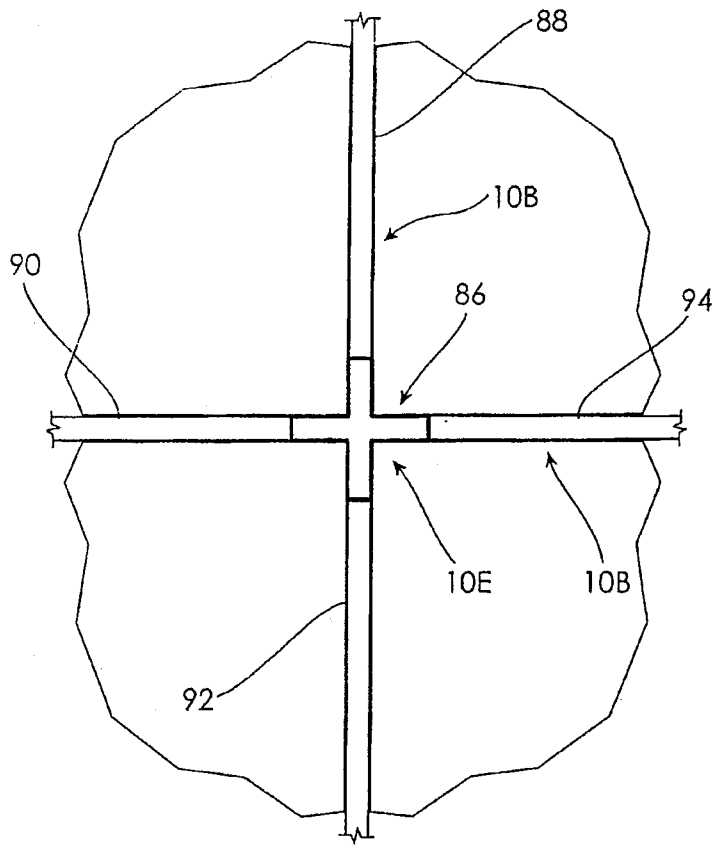

Fig. 15

