

(19)



(11)

EP 2 548 784 A2

(12)

EUROPEAN PATENT APPLICATION

(43) Date of publication:
23.01.2013 Bulletin 2013/04

(51) Int Cl.:
B61L 25/02 (2006.01) B61L 27/00 (2006.01)

(21) Application number: **12177162.0**

(22) Date of filing: **19.07.2012**

(84) Designated Contracting States:
AL AT BE BG CH CY CZ DE DK EE ES FI FR GB GR HR HU IE IS IT LI LT LU LV MC MK MT NL NO PL PT RO RS SE SI SK SM TR
Designated Extension States:
BA ME

(72) Inventors:
• **Imamoto, Kenji**
Chiyoda-ku, Tokyo 100-8220 (JP)
• **Maekawa, Keiji**
Chiyoda-ku, Tokyo 100-8220 (JP)
• **Sugita, Yoichi**
Chiyoda-ku, Tokyo 100-8220 (JP)

(30) Priority: **20.07.2011 JP 2011158975**

(74) Representative: **Gill, Stephen Charles**
Mewburn Ellis LLP
33 Gutter Lane
London
EC2V 8AS (GB)

(71) Applicant: **Hitachi Ltd.**
Tokyo 100-8280 (JP)

(54) Train control system

(57) In a train control system, in position estimating methods by a tacho-generator, an acceleration sensor, and the like, since estimation accuracy always changes because of a train state, a surrounding environment, and the like, it is difficult to assume an appropriate error and set the error as the safety margin distance, an excess safety margin distance is set, and service density is deteriorated. On-board equipment 20 of a train 2 includes an on-board clock 22 that specifies track information and transmission time information from a GPS satellite 1a and reception time of the information, an on-rail range calculating section 23 that calculates an on-rail range according to the received information and the reception time, an on-board communication section 24 that performs transmission of own train on-rail range information to track-side equipment 30 and reception of stop target information from the track-side equipment 30, and a speed control section 25 that controls traveling speed of the own train on the basis of the stop target information. The track-side equipment 30 includes a stop target calculating section 32 that calculates stop targets according to on-rail range information of respective trains. The track-side equipment 30 transmits the stop target information to the trains to attain an optimum service with high safety and service density and energy saving.

FIG. 1

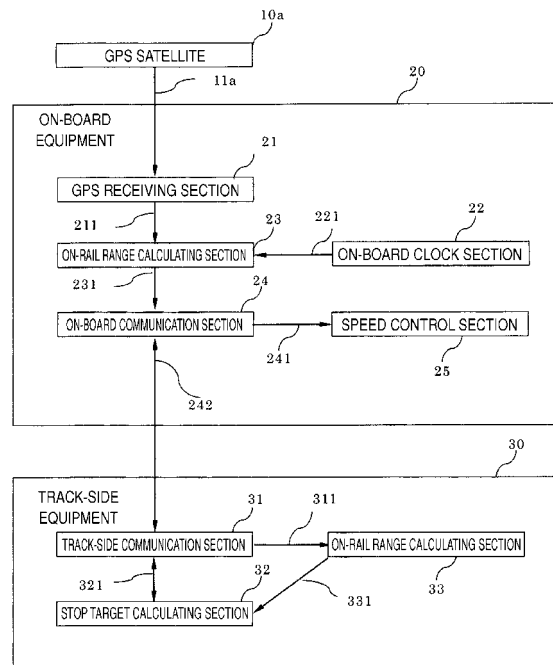

EP 2 548 784 A2

Description

BACKGROUND OF THE INVENTION

5 Field of the Invention

[0001] The present invention relates to a system that performs train control on the basis of train positions calculated by respective trains and a method for the system.

10 Description of the Related Art

[0002] In a railroad system, traveling control is performed by a railroad signal system to prevent trains from colliding with each other. In a conventional signal system employing track circuits, only one train is permitted to be on rails in one track circuit to secure safety among trains. Therefore, a train interval in a regular service depends on the length of the track circuits. In order to provide a high-density service, shorter track circuits should be used since it is necessary to reduce the train interval. However, the track circuits have a drawback in that equipment needs to be provided every several hundred meters, which leads to high installation and maintenance expenses for the equipment.

[0003] In a railroad security system including the signal system, from the viewpoint of a cost reduction and high functionality of train control, communication-based train control (CBTC) has been studied as a system for train control independent of the track circuits. In the communication-based train control, in general, equipment mounted on a car (hereinafter, on-board equipment) calculates an own train position and transmits the own train position to control equipment located on the ground (hereinafter, track-side equipment) by radio. The track-side equipment calculates a limit point for safe traveling of the train and transmits the limit point to the train. Using the limit point as a stop target, the respective trains control the trains themselves to be capable of safely stopping before the stop target.

[0004] A widely used position estimating method for the railroad security system is to utilize a tachogenerator. However, because of slipping wheels, a change in a wheel diameter, and the like, errors of estimated positions are accumulated as a train traveling distance increases. Transponders are used to correct the accumulated position detection errors. The transponders are devices that transmit position information to the on-board equipment and are provided along a railroad. A worst value of possible position errors is assumed from an interval of the transponders to fixedly set a margin distance for safety and calculate a stop target.

[0005] A small number of transponders and a large interval of the transponders lead to an increase in the position errors and also the safety margin distance. A large safety margin distance causes a problem such as a decrease in the service density due to the expansion of the train interval. If the on-board equipment fails to acquire the position correction information transmitted by the transponders, the position errors increase and safety is not guaranteed by the set safety margin distance.

[0006] Therefore, taking into account the failure to acquire the position correction information, the safety margin distance is set in advance to a value such that traveling is allowed for two transponders. If the on-board equipment fails to acquire the position correction information of the two transponders in a row, safety is secured by an emergency stop. Unfortunately, it is necessary to set the safety margin distance longer than necessary. The trains may stop because of abnormality of transponders. Further, the number of provided transponders is increased in order to reduce the safety margin distance, which leads to an increase in costs.

[0007] As a technique for solving these problems, Japanese Patent Laid-Open Publication No. 2010-120484 discloses a system for, if position correction by a transponder is failed, increasing the safety margin distance to cause the train to travel by a fixed amount (corresponding to an error that may occur before a train reaches the next transponder).

[0008] However, for position estimating methods by a tachogenerator, a GPS (Global Positioning System), an acceleration sensor, a Doppler radar, and the like, a surrounding environment, and the like, it is difficult to assume an appropriate error before traveling and set the error as the safety margin distance, since estimation accuracy continuously changes depending on a train state. Therefore, it is likely that an excess safety margin distance is set.

[0009] In the case of the GPS, a large number of systems for improving the position estimation accuracy are proposed. However, it is likely that errors increase because of the effect of, for example, a multi-path (reflection by an obstacle) and a propagation delay in the ionosphere, and a maximum error of the GPS is not guaranteed. In an application in which position information is directly related to safety such as the railroad signal system, the use of position information, a maximum error of which is not guaranteed, could lead to a fatal failure.

[0010] In the conventional position estimation system employing the GPS, GPS data is received from four GPS satellites and three-dimensional positions (the latitude, the longitude, and the altitude) of a reception place and a time error of a GPS receiving section are corrected on the basis of a difference between transmission time and reception time of the GPS data. If the multi-path or the propagation delay in the ionosphere occurs, an error is included in a position estimation result. Therefore, there is a system for correcting a position error by applying map matching. However, if a delay error

is large, it is likely that the position error is corrected to a wrong position.

[0011] It is an object of the present invention to provide a system applied to the railroad signal system. The system calculates a train on-rail range using data from the outside (e.g., time information and position information from the GPS) and enables safe train control.

5

SUMMARY OF THE INVENTION

[0012] In order to seek to attain the object, a train control system according to a first aspect of the present invention is a train control system that allows transmission and reception of information between a train and the outside of the train and controls a service of the train on the basis of the information, the train control system including: a transmitting and receiving section configured to receive position and time information including position information and time information from the outside; a measuring section configured to measure information concerning on-board time when the position and time information is received; an on-rail range calculating section configured to calculate on-rail range information of the train according to the position and time information and the information concerning on-board time when the position and time information is received; and a traveling control section configured to control traveling of the train. The train control system controls a start, speed, or a stop of the traveling of the train according to the on-rail range information.

10

15

[0013] In order to seek to attain the object, a train control system according to a second aspect of the present invention is a train control system that allows transmission and reception of information between a train and the outside of the train and controls a service of the train on the basis of the information, the train control system including: a train including: a transmitting and receiving section configured to receive position and time information including position information and time information from the outside; a measuring section configured to measure information concerning on-board time when the position and time information is received; an on-rail range calculating section configured to calculate on-rail range information of the train according to the position and time information and the information concerning on-board time when the position and time information is received; and a traveling control section configured to control traveling of the train; and track-side equipment configured to transmit the on-rail range information or the position and time information to the outside of the train and receive the on-rail range information or the position and time information. The track-side equipment includes: a track-side communication section configured to transmit and receive the information; and a train control information calculating section configured to calculate train control information from the received on-rail range information or position and time information. The train control system transmits the train control information from the track-side communication section to the train and performs traveling control for the train according to the on-rail range information or the train control information.

20

25

30

[0014] According to the present invention, it can be possible to realize a train control system that can follow, even if a delay error occurs in data reception time from the outside received by the own train or the preceding train, a change in the data reception time and calculate an optimum stop target from the viewpoints of safety, service density, and energy saving of the trains.

35

BRIEF DESCRIPTION OF THE DRAWINGS

40

[0015]

Figure 1 is a diagram showing the configuration of a train control system according to a first embodiment of the present invention;

Figure 2 is a flowchart for explaining a control flow in on-board equipment 20 in the second embodiment of the present invention;

45

Figure 3 is a flowchart for explaining a control flow in track-side equipment 30 in the first embodiment of the present invention;

Figure 4 is a conceptual diagram showing an on-rail range image in the first embodiment of the present invention;

Figure 5 is a diagram for explaining an on-rail range calculating method in the first embodiment of the present invention;

50

Figure 6 is a diagram for explaining on-rail range calculation with GPS data and map information in the first embodiment of the present invention;

Figure 7 is a diagram for explaining on-rail range calculation using transmission data of plural GPS satellite in the first embodiment of the present invention;

55

Figure 8 is a diagram showing the configuration of a train control system according to a second embodiment of the present invention;

Figure 9 is a diagram showing monitor display at normal time in a third embodiment of the present invention;

Figure 10 is a diagram showing monitor display during abnormal detection in the third embodiment of the present

invention; and

Figure 11 is a diagram showing the configuration of a train control system according to the third embodiment of the present invention.

5 DETAILED DESCRIPTION OF THE PREFERRED EMBODIMENTS

[0016] A best mode for carrying out the present invention is explained.

[First Embodiment]

10 [0017] A first embodiment of the present invention is explained with reference to Figures 1 to 7 and Figure 9. The configuration of a train control system is shown in Figure 1. In Figure 1, on-board equipment 20 includes a GPS receiving section 21 that receives GPS data 11a (track data and data transmission time information) transmitted by a GPS satellite 10a, an on-board clock 22 that specifies reception time 221 of the GPS data, and an on-rail range calculating section 23 that calculates on-rail range information 231 of an own train according to GPS data 211 received by the GPS receiving section 21 and the reception time 221.

15 [0018] The on-board equipment 20 further includes an on-board communication section 24 that performs transmission of the on-rail range information 231 to track-side equipment 30 and reception of information such as stop target information 321 transmitted from the track-side equipment 30 and a speed control section 25 that performs traveling speed control for the train according to a speed control signal 241 calculated according to the received stop target information 321.

20 [0019] The track-side equipment 30 includes a track-side communication section 31 that executes transmission of on-rail range information transmitted from respective trains and transmission of the stop target information 321 to the trains and a stop target calculating section 32 that calculates stop targets of the respective trains on the basis of an on-rail range of a train traveling on the same traveling path.

25 [0020] A control flow by the on-board equipment 20 is shown in Figure 2. A control flow by the track-side equipment 30 is shown in Figure 3. First, the on-board equipment 20 checks whether a stop target is received from the track-side equipment 30 (step 9100). If a stop target is not received (No in step 9100), the on-board equipment 20 checks whether the GPS data 11a is received by the GPS receiving section 21 (step 9102). If a stop target is received (Yes in step 9100), the on-board equipment 20 specifies, from the on-board clock 22, time when the GPS receiving section 21 receives the GPS data 11a (GPS data reception time 221) (step 9103).

30 [0021] The on-board equipment 20 inputs the received GPS data 211 and the GPS data reception time 221 to the on-rail range calculating section 23 (step 9104). The on-rail range calculating section 23 calculates on-rail range information 231 of the train according to the input data (step 9105) and transmits the on-rail range information 231 to the track-side equipment 30 through the on-board communication section 24 (step 9106).

35 [0022] On the other hand, as shown in Figure 3, if the track-side equipment 30 receives the on-rail range information 231 calculated by the on-rail range calculating section 23 of the on-board equipment 20 (Yes in step 9200), the track-side equipment 30 calculates stop target information 321 of the train taking into account an on-rail range of the preceding train traveling on the same traveling path (step 9201). The track-side equipment 30 transmits the stop target information 321 to the on-board equipment 20 through the track-side communication section 31 (step 9202). Subsequently, since the on-board equipment 20 receives the stop target information (Yes in step 9100 in Figure 2), the on-board equipment 20 executes speed control in step 9101 and enables the own train to safely stop at the stop target.

40 [0023] An image of calculation of an on-rail range by the on-rail range calculating section 23 is shown in FIGS. 4 and 5. In the following explanation, a distance from a GPS satellite 1a to the GPS receiving section 21 mounted on the on-board equipment 20 of a train 2 is referred to as reception distance. In Figure 4, reference numeral 101 corresponds to the reception distance. In this system, a difference between GPS data transmission time T_s (HH:MM:SS.SSSS) included in the GPS data 11a received from at least one GPS satellite 1a and reception time T_r when the GPS receiving section 21 receives the GPS data is set as propagation delay time T_{t1} . Therefore, the propagation delay time T_{t1} is represented as follows:

50

[Equation 1]

Propagation delay time T_{t1} = GPS data reception time

55

T_r - GPS data transmission time T_s

[0024] The reception distance 101 is calculated as follows:

[Equation 2]

$$Ln1 = \text{propagation delay time } Tt1 \times \text{light speed } C$$

5

[0025] A circumference portion where a sphere having the reception distance 101 as a radius overlaps the earth's surface (the ground) is an on-rail range of the train. The circumference portion is calculated from track information PS (Px, Py, Pz) transmitted from the GPS satellite 1a together with the transmission time information Ts. A center coordinate 14a of the circumference portion is (Px, Py). An inner circumference portion of a circle 203a having a radius (2031 in Figure 5) calculated as follows is the on-rail range:

10

[Equation 3]

$$Lhol_n1 = \sqrt{(Ln1^2 - Pz^2)}$$

15

[0026] However, in transmission data from the GPS satellite 1a orbiting at high altitude (several ten kilometers in the sky), further propagation delay time Td occurs because of the effect of the ionosphere, a multi-path, which is reception through an obstacle, or the like. Therefore, propagation delay time Tt2 is calculated as follows taking into account the effect:

20

[Equation 4]

$$\text{Propagation delay time } Tt2 = \text{propagation delay time}$$

$$Tt1 + \text{propagation delay time } Td$$

30

[0027] Simulative reception distance (hereinafter, pseudo-range) 102 is calculated as follows:

[Equation 5]

$$Ln2 = \text{propagation delay time } Tt2 \times \text{light speed } C$$

35

[0028] A circumference portion where a sphere having the pseudo-range 102 as a radius overlaps the earth's surface (the ground) is the on-rail range of the train. The center coordinate 14a of the circumference portion is (Px, Py). An inner circumference portion of a circle 204a having a radius (2041 in Figure 5) calculated as follows is the on-rail range:

40

[Equation 6]

$$Lhol_n2 = \sqrt{(Ln2^2 - Pz^2)}$$

45

[0029] A ground for guaranteeing that the train is not on rails on the outer side of the on-rail range 204a is explained. It is assumed that information (track information, GPS data, transmission time, and the like) included in the GPS data received from the GPS satellite 1a is correct and time information stored by the GPS satellite 1a and time stored by a clock of the on-board equipment 20 are also correct.

50

[0030] If the multi-path or the propagation delay time Td in the ionosphere does not occur, the pseudo-range 102 and the reception distance 101 are equal. On the other hand, if the multi-path or the propagation delay Td in the ionosphere occurs, the pseudo-range 102 is larger than the reception distance 101. This is because reception time is further delayed by the multi-path or the propagation delay in the ionosphere than a delay in reception time that occurs when the multi-path or the propagation delay Td in the ionosphere does not occur.

55

5 [0031] Specifically, if the multi-path or the propagation delay in the ionosphere occurs, the pseudo-range is larger than the reception distance and is never smaller than the reception distance. In other words, the circumference 204a calculated from the pseudo-range is larger the circumference 203a calculated from the reception distance by 205a. Therefore, even if the multi-path or the propagation delay in the ionosphere or the like occurs, it is guaranteed that a train is absent in a further distance than the circumference calculated from the pseudo-range, i.e., a train is always on rails within the circumference. This applies not only in the train 2. In another train 5 traveling on the same railroad 6 (which receives data from a GPS satellite other than the GPS satellite 1a), a circumference 504a calculated from a pseudo-range is larger than a circumference 503a calculated from a reception distance by 505a.

10 [0032] The on-rail range calculating section 23 can store two-dimensional or three-dimensional map information of the railroad 6 on which the train 2 travels. On the premise that the train 2 travels only on the railroad 6, a more accurate on-rail range can be specified by treating only a range 61 on a railroad included in the calculated on-rail range as an on-rail range using the stored map information. An image of calculation of an on-rail range 61 from the GPS data received from the GPS satellite 10a and the map information is shown in Figure 6. Incidentally, the map information can also be sequentially captured from the track-side equipment 30 through radio or wire 31 to be able to follow a change in a traveling state.

15 [0033] An on-rail range can also be changed according to the accuracy of the map information. For example, if the map information includes a fixed position error, a range including the error is applied as the on-rail range. Consequently, for example, it is possible to narrow the on-rail range by using detailed map information and realize high service density. On the other hand, in a low-density train line, since a detailed map is unnecessary, it is possible to reduce costs for a topography survey in creating a map.

20 [0034] If a train on-rail range is calculated by the on-rail range calculating section 23 shown in Figure 1, for example, any one of a track circuit, an acceleration sensor, a gyro sensor, a tacho-generator, a transponder, a balise, radio information of a wireless LAN, an ultrasonic sensor, a Doppler radar, a camera, an infrared sensor, an axle counter is used together with the GPS to calculate the train on-rail range. This makes it possible to specify a more accurate on-rail range. The on-rail range calculating section 23 may use one kind of devices among the abovementioned device or may use plural kinds of devices in combination. It is also possible to properly use devices in use as appropriate according to a traveling point. Further, a position specifying technique widely used in the conventional train control and car navigation systems may be used.

25 [0035] As an example of calculating an on-rail range using the device other than the GPS in the on-rail range calculating section 23, processing performed using the tacho-generator together with the GPS is explained. The tacho-generator is a device used for measuring a traveling distance. Errors increase in proportion to the traveling distance because of a slip during traveling, an error of a wheel diameter, and the like. Therefore, an on-rail range is calculated taking into account about several percent of the traveling distance as an error range. It is possible to grasp a more accurate on-rail range by calculating, as an on-rail range, an on-rail range calculated using GPS data and an on-rail range calculated using the tacho-generator. Consequently, for example, in an environment such as the inside of a tunnel, even in a section where reception of the GPS data is difficult, it is possible to prevent a sudden expansion of an on-rail range and secure reliability of a train service by calculating the on-rail range using the device such as the tacho-generator together with the GPS.

30 [0036] If traveling speed is controlled by the speed control section 25 shown in Figure 1, the traveling speed is calculated using at least one of an on-rail range of a train, traveling speed, a distance to a stop target, topological information (a curvature of a traveling path, a gradient, and the like), car performance (motor performance, brake performance, weight, and the like). As a method of calculating traveling speed taking into account service density and energy saving while securing safety, there is a method of creating an energy saving drive curve taking into account a speed limit between stations.

35 [0037] If a stop target is calculated by the stop target calculating section 32, for example, as shown in Figure 5, the on-rail range 504a of a preceding train 50 traveling on the same traveling path 6 is calculated. A point 206 closest from the on-rail range 204a of the own train 2 is set as a stop target. According to this control, the track-side equipment 30 can set a stop target corresponding to a change in on-rail ranges of respective trains. It is possible to perform train control corresponding to the performance of the on-rail range calculating sections 23 of the respective trains. It is also possible to control the services of the respective trains by directly exchanging on-rail ranges between trains (e.g., the train 2 and the train 5 shown in Figure 5) not via the track-side equipment 30.

40 [0038] If a stop target is calculated by the method, when propagation delay errors of GPS data in the preceding train or the own train increase because of a change in the surrounding environment or the like, in some case, a stop target shifts to behind a point of a previous stop target with respect to a traveling direction. In this case, it is assumed that the own train cannot stop before the stop target depending on a situation, an emergency brake is applied, and riding comfort and energy saving properties are markedly deteriorated.

45 [0039] Therefore, for example, if propagation delay errors of GPS data increase and a point behind a stop target at the present point in time is calculated as a stop target, the stop target is not updated and the stop target at the present

point in time is continuously used. For example, in a train, a reception environment of the GPS is extraordinarily deteriorated, the stop position is fixed near the entrance of the tunnel while the train is passing the tunnel. The stop position shifts to near the exit of the tunnel at a point in time when the train finishes passing the tunnel. If it is likely that the preceding train moves back, a point obtained by subtracting, from the stop target, a distance that the preceding train is likely to move back only has to be set as a stop target.

[0040] As shown in Figure 9, the on-board equipment 20 or the track-side equipment 30 can also include a monitor 4 and include means for displaying processing situations of the devices or informing the processing situations by sound. In the above explanation, the track-side equipment 30 transmits stop target information to the on-board equipment 20. However, the track-side equipment 30 may transmit speed limits of the train at respective points to the on-board equipment 20 instead of the stop target.

[0041] In the configuration of this embodiment, the on-board equipment 20 includes the on-rail range calculating section 23. However, the track-side equipment 30 may include the on-rail range calculating section 23. In that case, after the GPS receiving section 21 receives the GPS data 11a, the on-board equipment 20 transmits the GPS data 11a and the reception time information 221 of the reception by the GPS receiving section 21 to the track-side equipment 30. It is also possible to use the devices (e.g., the tacho-generator and the transponder) other than the GPS together with the GPS, transmit information obtained by the devices to the track-side equipment 30 as well, and calculate an on-rail range.

[0042] The track-side equipment 30 inputs the information received from the on-board equipment 20 to an on-rail range calculating section 33, calculates an on-rail range 331, calculates a stop target 321 of the train taking into account an on-rail range of the preceding train traveling on the same traveling path, and transmits the on-rail range 331 and the stop target 321 to the on-board equipment 20. Processing performed thereafter is assumed to be same as the processing in the abovementioned configuration. In the configuration, since the on-board equipment 20 does not need to include the on-rail range calculating section 23, it is possible to simplify the configuration of the on-board equipment 20.

[0043] In a configuration in which the track-side equipment 30 includes the on-rail range calculating section 33 and the on-board equipment 20 does not include the on-rail range calculating section 23, the track-side equipment 30 grasps an on-rail range using information transmitted from the on-board equipment 20. However, the track-side equipment 30 can also calculate an on-rail range using information other than the information transmitted from the on-board equipment 20.

[0044] The configuration is a configuration in which the information is directly input to the track-side equipment 30 not through the on-board equipment 20. Examples of the configuration include information input from a device located on the ground side such as a track circuit or an axle counter. In this configuration, the track-side equipment 30 calculates an on-rail range and controls a service on the basis of information acquired by the device located on the ground side other than the information input from the on-board equipment 20 of respective trains.

[0045] In the train control system explained above, as an application example, a GPS in the United States is used. However, the train control system can also be applied to other global positioning systems (e.g., Galileo in Europe, GLONASS in Russia, and Hokuto in China).

[0046] In the configuration of this embodiment, the track-side equipment 30 calculates a stop target. However, the on-board equipment 20 may calculate a stop target. In this configuration, for example, the on-board equipment 20 includes the on-rail range calculating section 23 and the stop target calculating section 32. In this configuration, the on-board equipment 20 calculates an on-rail range of the own train with the on-rail range calculating section 23 and transmits the on-rail range 204a of the own train to the other train 5 traveling on the same traveling path 6. The on-board equipment 20 receives the on-rail range 504a from the other train 5 traveling on the same traveling path 6. If the on-rail range 504a is received from the other train 5, the on-board equipment 20 calculates the point 206 closest from the on-rail range 204a of the own train 2 as a stop target and controls the traveling speed of the own train 2.

[0047] In the configuration of this embodiment, the on-board equipment 20 includes one GPS receiving section 21 to make it possible to receive data from one or more GPS satellites. However, the on-board equipment 20 may include plural GPS receiving sections 21 and the respective GPS receiving sections 21 may correspond to the respective GPS satellites in a one-to-one relation and receive data. The on-board equipment 20 including one GPS receiving section 21 may be provided for each one train car and a plurality of the train cars may be coupled to compose the train 2.

[0048] The on-rail range calculating section 23 can also calculate an on-rail range on the basis of GPS data received by the plural GPS receiving sections 21. That can be attained by, in calculating an on-rail range on the basis of the GPS data of the plural GPS receiving sections 21, measuring locations of the respective GPS receiving sections 21 in advance and using a relative positional relation as an offset in calculating an on-rail range.

[0049] For example, if one GPS receiving section 21 is provided at each of the leading end and the trailing end of a train having composition length of 100 meters, it is also possible to move an on-rail range, which is calculated from GPS data received by the GPS receiving section 21 at the trailing end, forward 100 meters along a traveling direction on a railroad on which the train travels, compare the on-rail range with an on-rail range calculated from GPS data received by the GPS receiving section 21 at the leading end, and set an overlapping portion as a range in which the leading end of the train is on rails.

5 [0050] If GPS data is received from plural GPS satellites, a circumference portion where a sphere formed by a reception distance (or a pseudo-range) overlaps the earth's ground is calculated for each of the GPS satellites and a portion where circumferences overlap one another is set as an on-rail range. An image of calculation of an on-rail range from GPS data received from plural satellites 1 is shown in Figure 7. It is possible to specify a more highly accurate on-rail range by receiving track information (position information) and time information from the plural GPS satellites in this way. In the above explanation, the GPS satellite originates information received from the outside of the train 2. However, this is not a limitation.

10 [Second Embodiment]

15 [0051] In the first embodiment, the on-rail range calculating section 23 performs the traveling control on the basis of the GPS data received at the present point in time. An error change in traveling in future is not taken into account. For example, when a train passes a tunnel, a GPS data reception environment is suddenly deteriorated. Therefore, it is conceivable that an on-rail range expands and the following train needs to quickly decelerate. Conversely, when the preceding train passes the tunnel, the GPS data reception environment is suddenly improved and the on-rail range is narrowed. Therefore, quick acceleration is necessary to increase service density.

20 [0052] Therefore, in a configuration of a second embodiment, the on-board equipment 20 or the track-side equipment 30 includes an on-rail range predicting section 34 that predicts a change in on-rail range of respective trains. A configuration in which the track-side equipment 30 includes the on-rail range predicting section 34 is shown in Figure 8. The track-side equipment 30 predicts an on-rail range of a train at a certain point in time in future using a predicted on-rail range predicted by the on-rail range predicting section 34. The track-side equipment 30 calculates a predicted stop target of the train taking into account a predicted on-rail range of the preceding train traveling on the same traveling path at the same point in time and transmits the predicted stop target to the on-board equipment 20.

25 [0053] If the on-board equipment 20 receives the predicted stop target, the on-board equipment 20 controls traveling speed such that, at the point in time, the own train can stop at the predicted stop target safely and taking into account energy saving properties. With this configuration, if the preceding train travels in a section where it is possible to predict in advance that a reception environment of GPS data is deteriorated, the on-board equipment 20 can travel with unnecessary acceleration and deceleration suppressed by traveling while controlling speed on the basis of the predicted stop target. Consequently, the track-side equipment 30 can set a stop target to correspond to a future change in on-rail ranges of the on-board equipment 20. It is possible to perform train control with safety, service density, and energy saving properties further improved.

30 [0054] A large number of methods are proposed as a method of predicting, on the basis of various kinds of information, a tendency of data that successively changes. For example, a Kalman filter is used for calculating positions of a target object at respective points of time in the past, at present, and in future on the basis of sensor information. By applying these methods, it is possible to improve position calculation accuracy and a presence probability.

35 [0055] The on-rail range predicting section 34 can predict an on-rail range in future as well on the basis of change data of an on-rail range acquired during traveling in the past. The same effect can be obtained by providing, in the track-side equipment 30, a database for recording on-rail range information of respective trains collected in traveling in the past and providing the on-rail range predicting section 34 that predicts a change in an on-rail range on the basis of the recorded information.

40 [0056] It is also possible to give the map information (a tunnel position, a gradient, a bending ratio, and the like) shown in Figure 6 to the on-rail range predicting section 34 and predict a change in a GPS reception environment from the map information. The same prediction effect can be obtained by providing, in the track-side equipment 30, a database for recording at least one of topological data of a traveling path, location data of a transponder, structure data (a tunnel position and the like) in the periphery, a traveling timetable, car performance data, GPS satellite data, and weather data and providing the on-rail range predicting section 34 that predicts a change in an on-rail range on the basis of the recorded information.

45 [0057] If train traveling is performed taking into account energy saving, it is important to reduce unnecessary acceleration and deceleration and increase coasting. In an environment in which a stop target substantially fluctuates because of a change in on-rail range calculation accuracy, unnecessary acceleration and deceleration increase if speed is changed following the stop target. This causes deterioration in energy saving properties. It is possible to predict fluctuation in a stop target by using the on-rail range predicting section 34. Therefore, it is possible to calculate optimum traveling speed taking into account even fluctuation of the stop target in future.

50 [Third Embodiment]

55 [0058] In the explanation of the first and second embodiments, it is assumed that the track information (the position information) and the transmission time information of the GPS data received by the GPS satellite 1a and the reception

time information specified by the on-board clock of the on-board equipment 20 are correct. However, likelihood that the information is wrong has to be taken into account.

5 [0059] Therefore, in a third embodiment, the on-board equipment 20 or the track-side equipment 30 includes a GPS monitoring section 26 that monitors GPS data transmitted by a GPS satellite. If an error is included in information (track information, GPS data transmission time, and the like) included in the GPS data, the GPS monitoring section 26 outputs a warning to the on-board equipment 20. If the on-board equipment 20 receives the warning, the on-board equipment 20 corrects at least one of a stop target, an on-rail range, and control speed according to the error and executes notification to the track-side equipment 30 and train control.

10 [0060] A configuration in which the on-board equipment 20 includes the GPS monitoring section 26 is shown in Figure 11. As a method for the GPS monitoring section 26 to detect an error, a differential GPS (hereinafter, DGPS), a satellite-based augmentation system, or the like is used, which is a system for providing, for example, a stationary station, which has an accurate clock and a coordinate of which is known, and improving accuracy from a difference between a position calculated from GPS reception data and the position of the stationary station.

15 [0061] As a method of correcting a time error of the on-board clock 22, a system for performing time correction using GPS data received from four GPS satellites is generally adopted. However, since a propagation delay error such as a multi-path is included, it is likely that sufficient safety cannot be guaranteed by the time correction using the GPS data. Therefore, in the present invention, in calculating an on-rail range from the received GPS data, the on-board equipment 20 communicates with the track-side equipment 30, which stores an accurate clock, and corrects the time error of the on-board clock 22 according to accurate clock information 222 received by the on-board equipment 20.

20 [0062] The track-side equipment 30 stores the accurate clock according to an NTP (Network Time Protocol), which is a communication protocol for synchronizing the DGPS or a clock of a connection apparatus to a network 70 shown in Figure 6 with accurate time.

25 [0063] Even if time is corrected, an error occurs in time of the on-board clock 22 again because of an elapse of time. Therefore, the on-rail range calculating section 23 in the present invention can store a nominal error of a manufacture of the on-board clock 22 and calculate an on-rail range expanded according to a difference between the corrected time and GPS data reception time.

30 [0064] For example, if the on-board clock 22 having a nominal error of ± 1 ppm is used and time correction is performed after 200 milliseconds from the reception of GPS data, the on-board clock 22 shifts 1/5 million second in 200 milliseconds at the maximum. Since a radio wave travels about 60 meters in 1/500 million second, the on-rail range calculating section 23 calculates an on-rail range using a pseudo-range expanded by 60 meters.

35 [0065] As a method of correcting a time error of the on-board clock 22, a conventional system for performing time correction using GPS data received from a GPS satellite, which is generally adopted, may be adopted. If the GPS satellite is used, a coordinate value and corrected time at a reception point are calculated. In order to prevent a time correction error due to a propagation delay error such as a multi-path of the GPS satellite, the coordinate value of the reception point calculated from the GPS data and a coordinate value of a presence point calculated by another position estimating system such as a tachogenerator are compared and reliability of the time correction is verified on the basis of a shift between the coordinate values.

40 [0066] On the premise that information (track information, GPS data transmission time, and the like) included in the GPS data is not wrong and time information stored by the GPS satellite and reception time specified by the clock of the on-board equipment 20 are correct, the train is on rails in the on-rail range obtained from the GPS data. Therefore, as shown in Figure 7, if an on-rail range is calculated using GPS data received in the same period of time by plural GPS satellites, a place where all on-rail ranges calculated from the GPS data overlap one another is always present.

45 [0067] However, if the premise does not hold, it is likely that a place where the on-rail ranges partially do not overlap one another is present. This is because the on-board clock 22 operates faster than a normal clock and a pseudo-range becomes shorter than a reception distance.

50 [0068] Therefore, the GPS monitoring section 26 compares on-rail ranges 263 calculated from the received respective GPS data 211 and confirms that a place where all the on-rail ranges calculated from the GPS data overlap one another (e.g., 204c in Figure 7) is present. If at least one place where the on-rail ranges do not overlap each other is present, the GPS monitoring section 26 determines that there is an error of the GPS data or abnormality of the on-board clock 22 and outputs the error or the abnormality to the track-side equipment 30 as warning information 262. With this configuration, it is possible to instantly detect abnormality of the GPSs.

55 [0069] At the same time, the GPS monitoring section 26 outputs speed control information 261 to the speed control section 25 and executes deceleration of the train 2 (for changing traveling speed from 41a in Figure 9 to 41b in Figure 10 and changing a traveling pattern from 44a to 44b), a change of a stop target point (for changing the stop target point from 46a to 46b, 200 m before 46a, and changing a travelable distance from 1900 m of 45a to 1700 m of 45b).

[0070] The GPS monitoring section 26 monitors reception information 212 (the number of reception satellites, reception sensitivity, and the like) received by the GPS receiving section 21. For example, whereas the number of GPS satellites acquired at normal time is five as indicated by 47a in Figure 9, only three GPS satellites can be acquired at abnormal

time as indicated by 47b in Figure 10. Even in such a case, it is possible to perform the abnormality notification and the service control as explained above.

[0071] Further, the on-board equipment 20 or the track-side equipment 30 can grasp a state on the monitor 4. Therefore, it is possible to specify a cause of the abnormality and manually perform train service control (deceleration, a change of a stop target, and the like).

[0072] In the above embodiments, the train control system is explained. However, the present invention is applicable to, in the same configuration, mobile control systems for airplane service control, automobile control, elevator control, and the like.

[Reference Signs List]

[0073]

- 10a, 10b GPS satellites
- 101 reception distance
- 102 pseudo-range
- 2, 5 trains
- 20 on-board equipment
- 21 GPS receiving section
- 22 on-board clock section
- 23 on-rail range calculating section
- 24 on-board communication section
- 25 speed control section
- 26 GPS monitoring section
- 27 map information section
- 204a, 204b, 203c, 504a on-rail ranges
- 30 track-side equipment
- 31 track-side communication section
- 32 stop target calculating section
- 33 on-rail range calculating section
- 34 on-rail range predicting section
- 35 track-side clock section
- 4 monitor
- 6 railroad
- 61 on-rail range

Claims

1. A train control system that allows transmission and reception of information between a train and an outside of the train and controls a service of the train on the basis of the information, wherein the train control system comprises:

- a transmitting and receiving section configured to receive position and time information including position information and time information from the outside;
- a time measuring section configured to measure information concerning on-board time when the position and time information is received;
- an on-rail range calculating section configured to calculate on-rail range information of the train according to the position and time information and the information concerning on-board time when the position and time information is received; and
- a traveling control section configured to control traveling of the train, wherein the train control system controls a start, speed, or a stop of the traveling of the train according to the on-rail range information.

2. A train control system that allows transmission and reception of information between a train and an outside of the train and controls a service of the train on the basis of the received information, wherein the train control system comprises:

- a train having on-board equipment including:

a transmitting and receiving section configured to receive position and time information including position information and time information from the outside;
a time measuring section configured to measure information concerning on-board time when the position and time information is received;
5 an on-rail range calculating section configured to calculate on-rail range information of the train according to the position and time information and the information concerning on-board time when the position and time information is received; and
a traveling control section configured to control traveling of the train; and

10 track-side equipment configured to transmit the on-rail range information or the position and time information to the outside of the train and receive the on-rail range information or the position and time information, wherein the track-side equipment includes:

15 a track-side communication section configured to transmit and receive the information; and
a train control information calculating section configured to calculate train control information from the received on-rail range information or position and time information, and

20 the train control system transmits the train control information from the track-side communication section to the train and performs traveling control for the train according to the on-rail range information or the train control information.

- 25 3. The train control system according to claim 1 or 2, wherein the on-rail range calculating section records map information including at least one of two-dimensional or three-dimensional position information of a railroad on which the train is traveling and position accuracy information of a map and calculates an on-rail range on the basis of the map information.
- 30 4. The train control system according to any one of the previous claims, wherein the on-rail range calculating section calculates, in calculating a train on-rail range, an on-rail range using both the external data and information acquired using at least one device among a track circuit, an acceleration sensor, a gyro sensor, a tachometer, a transponder, a balise, radio wave information of a wireless LAN, an ultrasonic sensor, a Doppler radar, a camera, an infrared sensor, and an axle counter.
- 35 5. The train control system according to any one of the previous claims, further comprising a stop target calculating section configured to calculate, in calculating a stop target, a stop target at a last calculation point if a stop target of a preceding train or the own train shifts to behind a stop target at the last calculation point with respect to a traveling direction or, if the preceding train is likely to move back, calculate a point obtained by subtracting, from the stop target, a distance that the preceding train is likely to move back.
- 40 6. The train control system according to claim 2, or any one of claims 3 to 5 as dependent on claim 2, wherein the track-side equipment includes an on-rail range calculating section, and the track-side equipment inputs the data received from the on-board equipment to the on-rail range calculating section to calculate an on-rail range.
- 45 7. The train control system according to claim 2, or any one of claims 3 to 5 as dependent on claim 2, wherein the track-side equipment calculates an on-rail range using information input to the track-side equipment not through the on-board equipment and uses information acquired using at least one device located on a ground side among a track circuit, an ultrasonic sensor, a Doppler radar, a camera, an infrared sensor, and an axle counter and the external data.
- 50 8. The train control system according to any one of the previous claims, wherein the on-board equipment or the track-side equipment includes a monitor that displays processing situations of the respective pieces of equipment or means for informing the processing situations by sound.
- 55 9. The train control system according to claim 2, or any one of claims 3 to 8 as dependent on claim 2, wherein the track-side equipment transmits speed limits of the trains at respective points to the on-board equipment instead of a stop target.
10. The train control system according to claim 1 or 2, wherein

the on-board equipment includes a stop target calculating section,
the on-board equipment calculates an on-rail range of the own train with the on-rail range calculating section and
transmits and receives the on-rail range to and from other trains traveling on a same traveling path, and
the stop target calculating section calculates a stop target on the basis of the on-rail range and controls traveling
speed of the own train.

- 5
11. The train control system according to any one of the previous claims, wherein
the on-board equipment includes a plurality of receiving devices for trains of one composition, and
the on-rail range calculating section measures and records location information of the receiving devices in advance
and calculates an on-rail range on the basis of data received by the plurality of receiving devices and the location
information of the receiving devices.
- 10
12. The train control system according to any one of the previous claims, wherein
the on-board equipment or the track-side equipment includes an on-rail range predicting section, and
the on-rail range predicting section predicts on-rail ranges of respective trains at a certain point in time in future and
calculates predicted stop targets of the trains taking into account an on-rail range of a preceding train traveling on
a same traveling path at a same point in time.
- 15
13. The train control system according to any one of the previous claims, wherein
the on-board equipment or the track-side equipment includes an external information monitoring section that monitors
information received from the outside,
the track-side equipment includes a clock, includes means for recording a location of the track-side equipment in
advance and detecting at least one kinds of information of position information and external data transmission time
among information included in external data received by an external receiving device, and outputs a warning to the
on-board equipment when an error of the external data is detected.
- 20
- 25
14. The train control system according to any one of the previous claims, wherein, as a method of correcting a time
error in the time measuring section, the train control system compares a coordinate value and correction time of an
on-rail point calculated from external data and an on-rail point calculated from information acquired using at least
one device among a track circuit, an acceleration sensor, a gyro sensor, a tacho-generator, a transponder, a balise,
radio wave information of a wireless LAN, an ultrasonic sensor, a Doppler radar, a camera, an infrared sensor, and
an axle counter and verifies reliability of time correction on the basis of a shift between the coordinate value and
the correction time and the on-rail point.
- 30
- 35
15. The train control system according to claim 13, wherein the external information monitoring device compares on-
rail ranges calculated from the external data, confirms that a place where all the on-rail ranges calculated from the
external data overlap one another is present, and, if the place where all the on-rail ranges overlap one another is
absent, determines that there is an error of at least one kind of information of the position information and the data
transmission time among the information included in the external data or abnormality of the time measuring section,
and outputs a warning to the on-board equipment.
- 40
- 45
- 50
- 55

FIG. 1

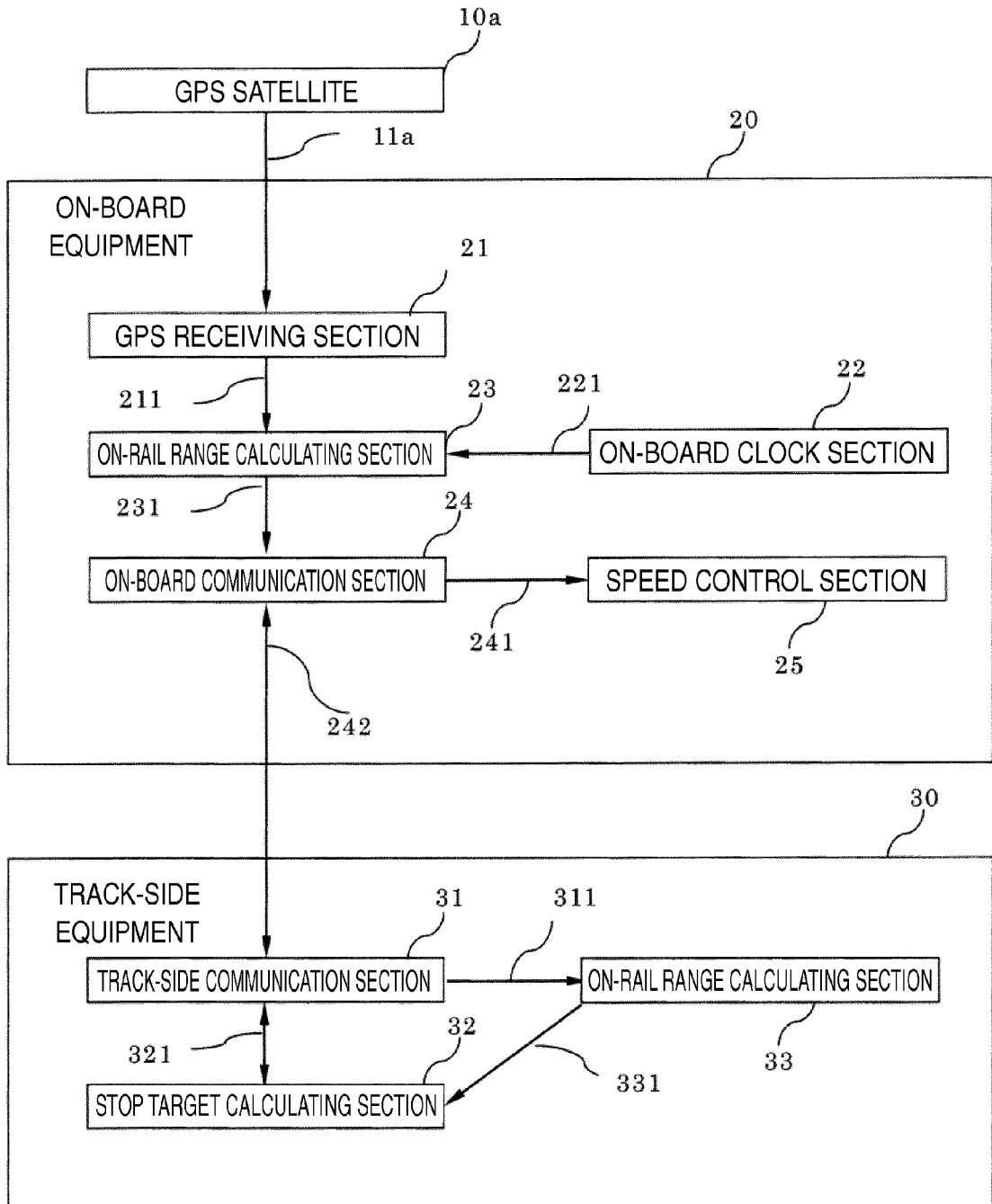

FIG. 2

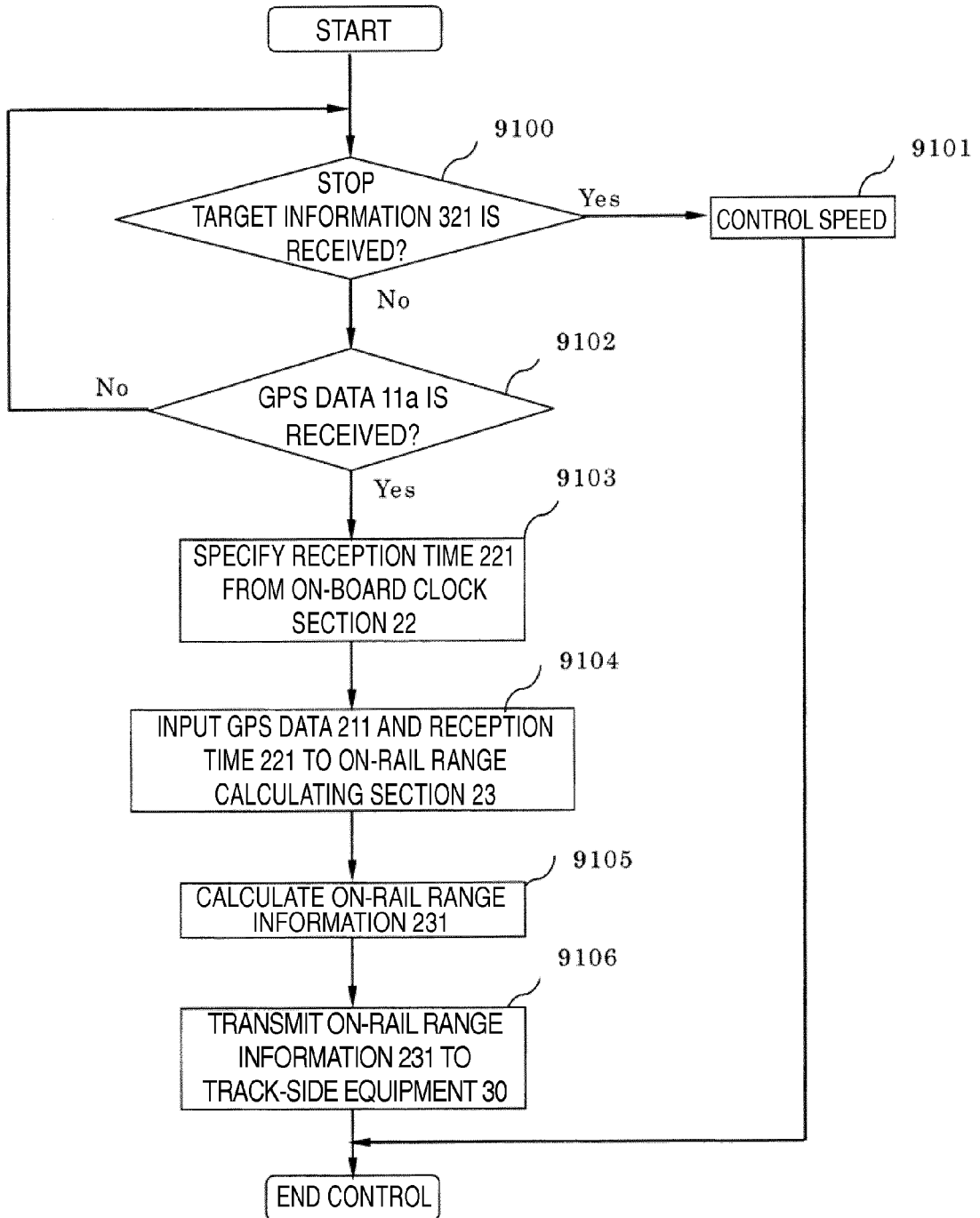

FIG. 3

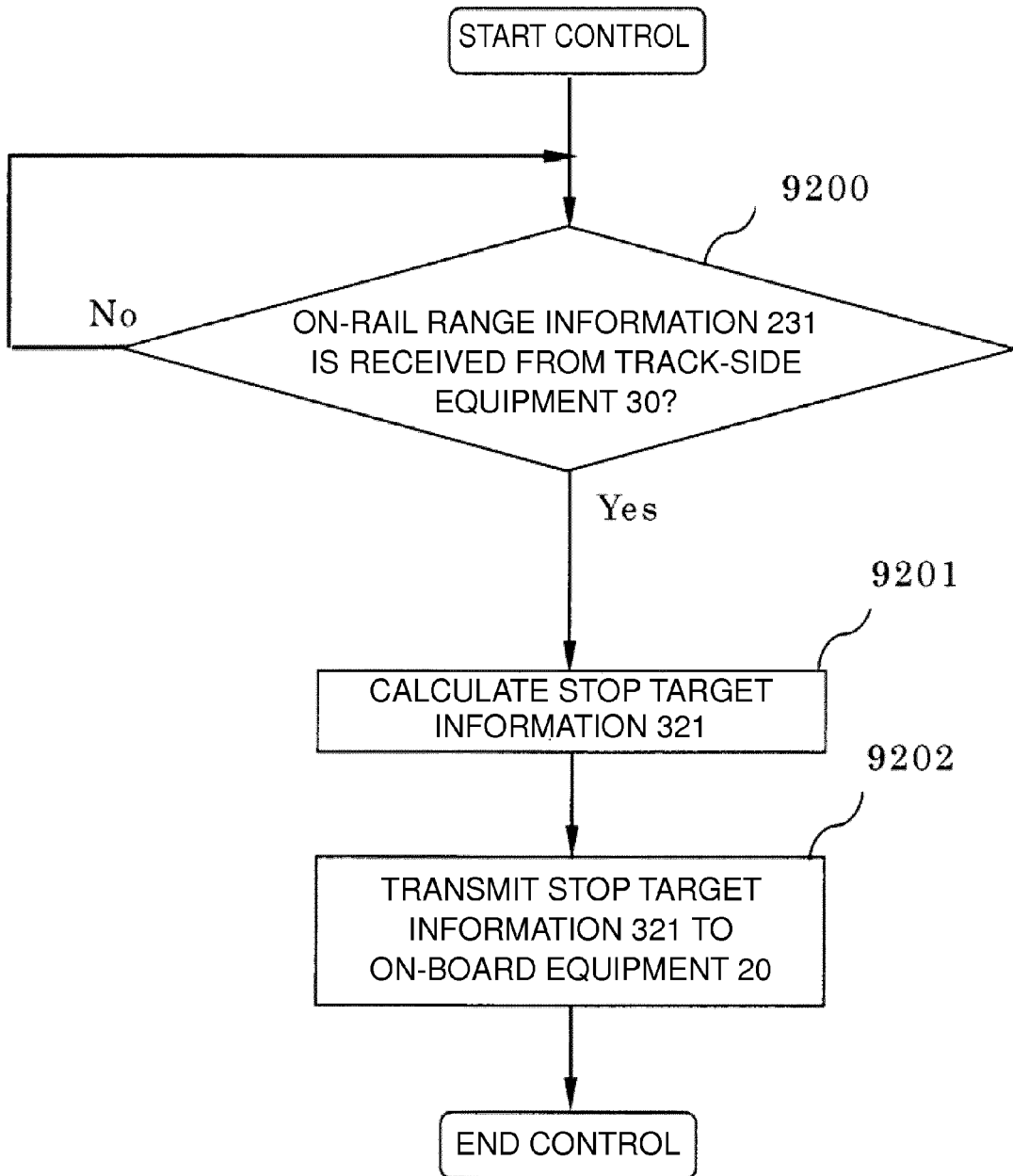

FIG. 4

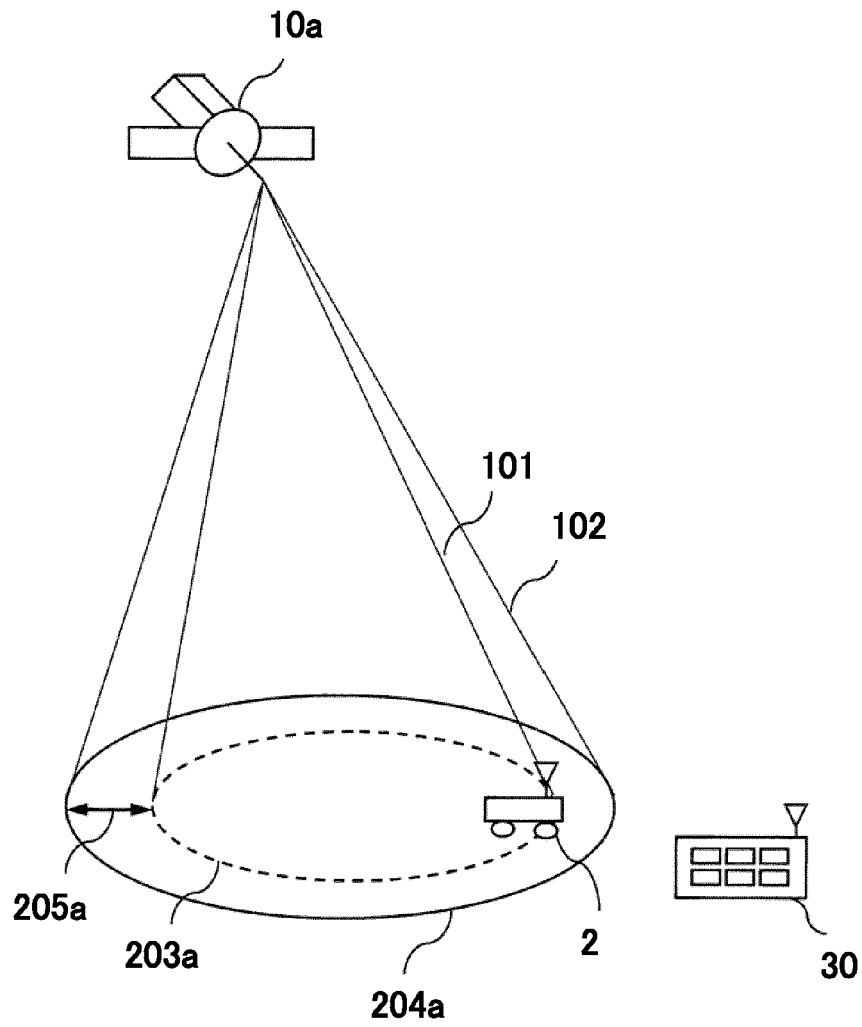

FIG. 5

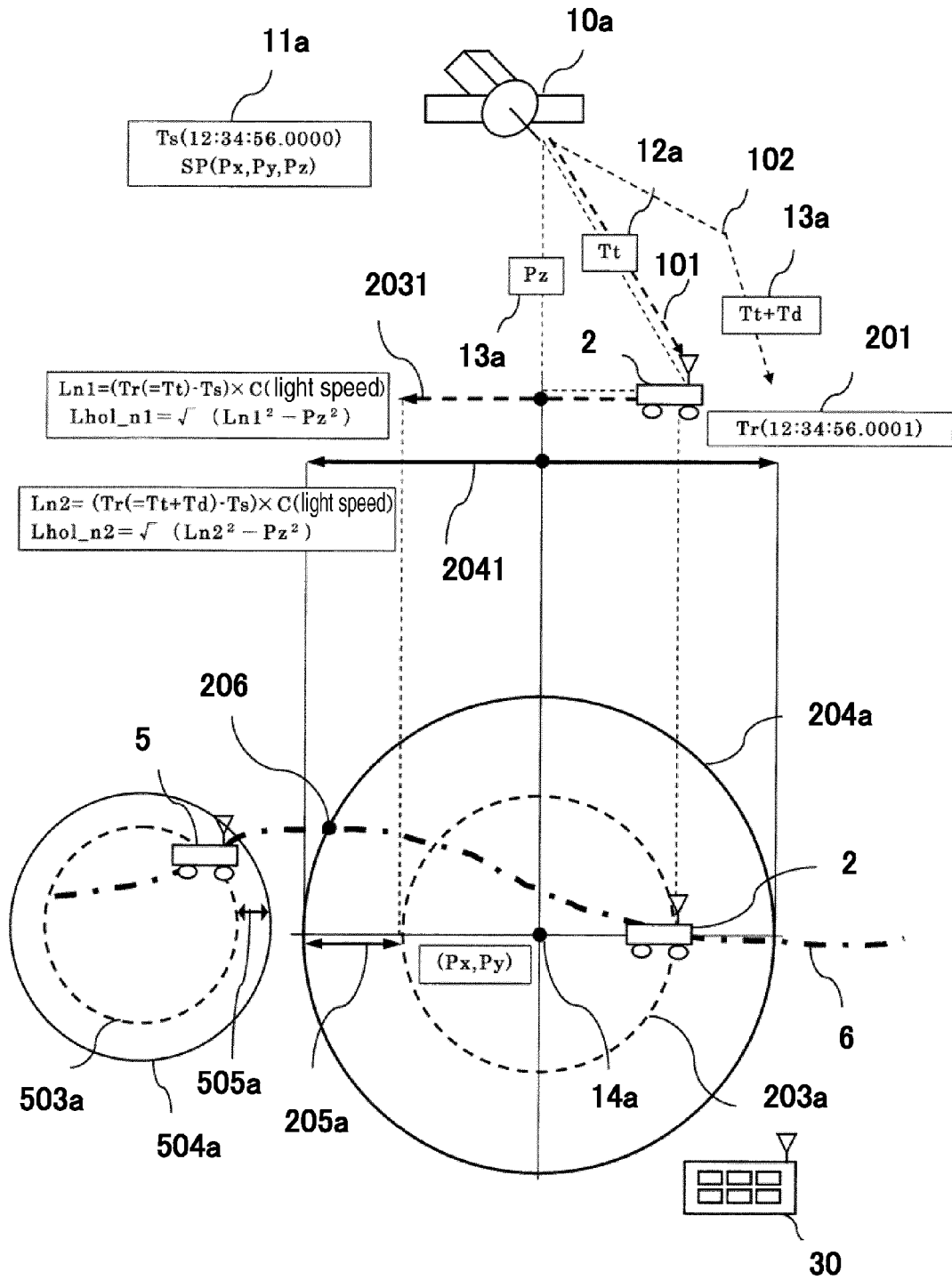

FIG. 6

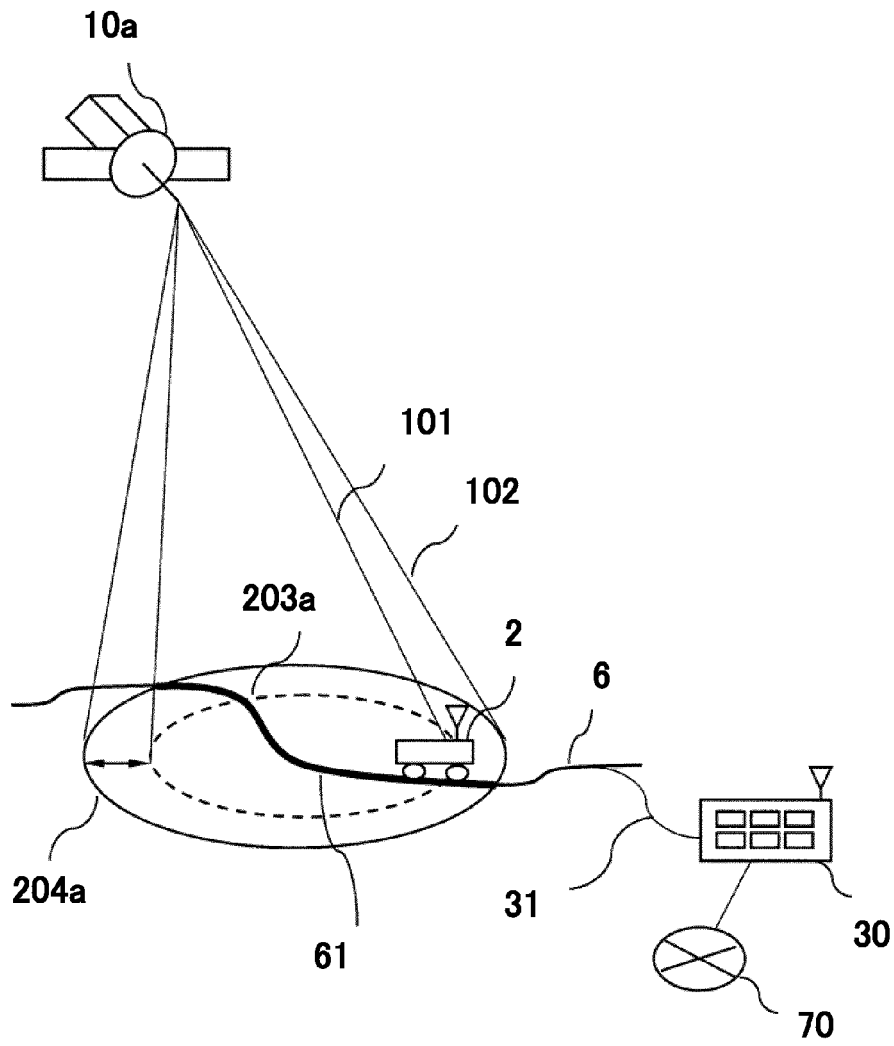

FIG. 7

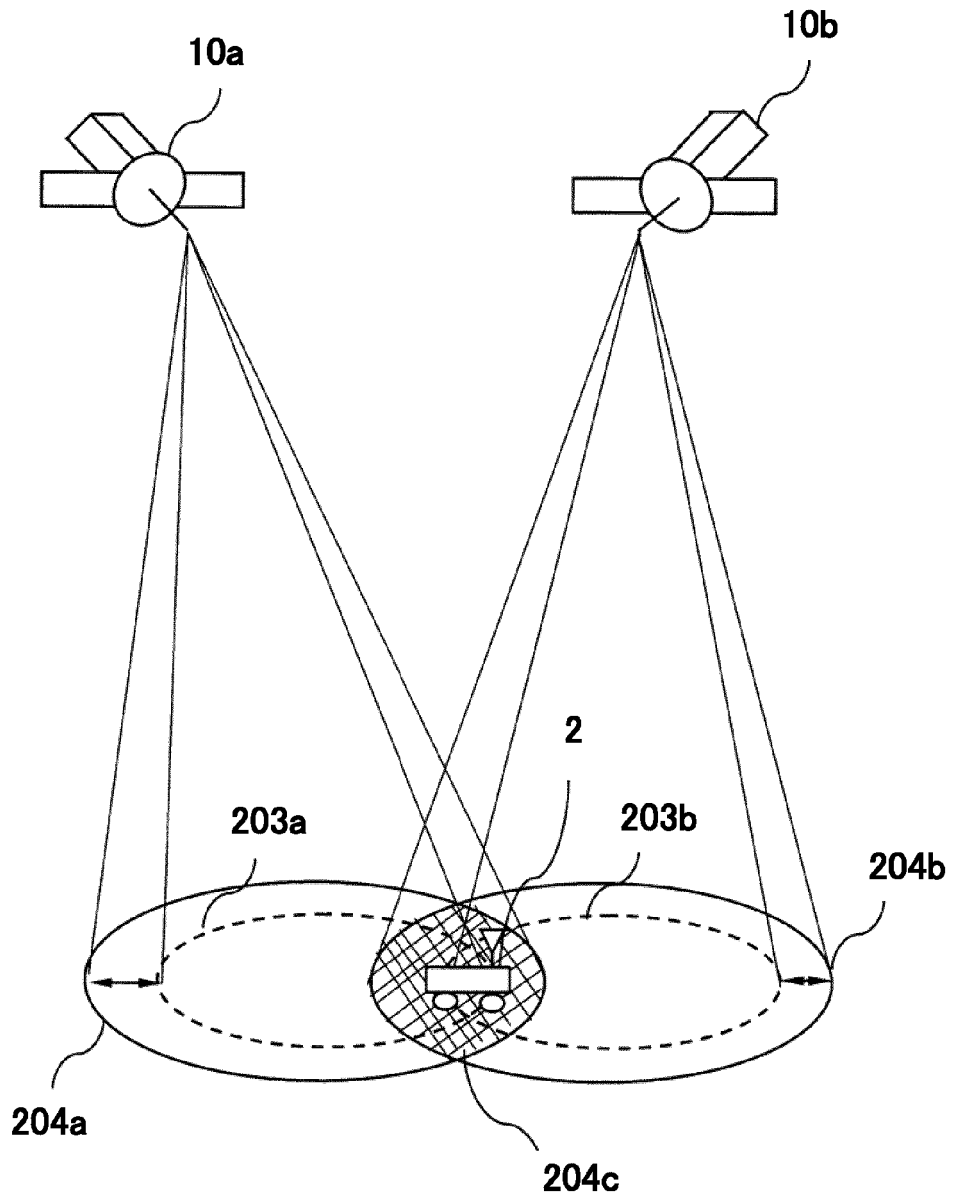

FIG. 8

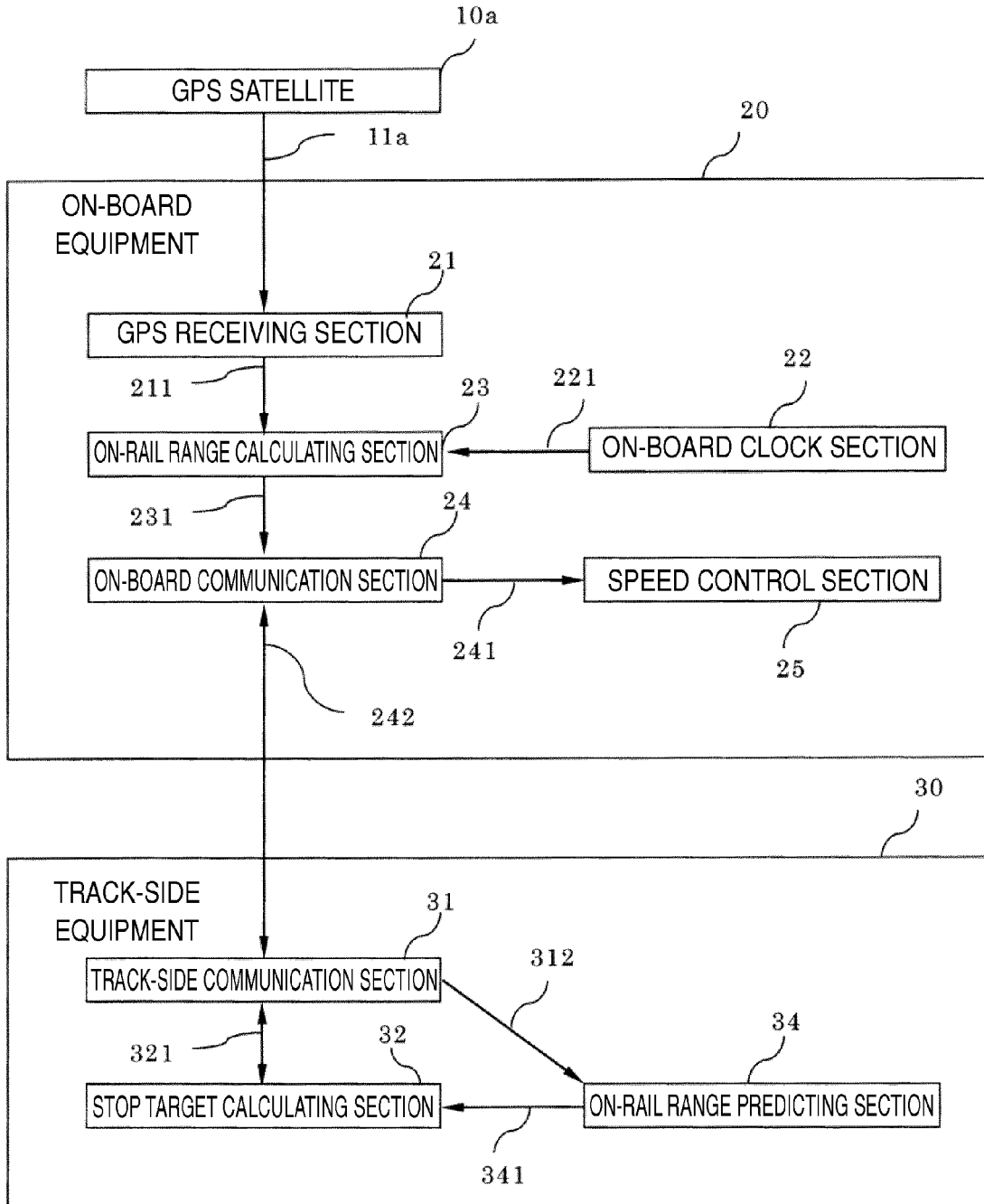

FIG. 9

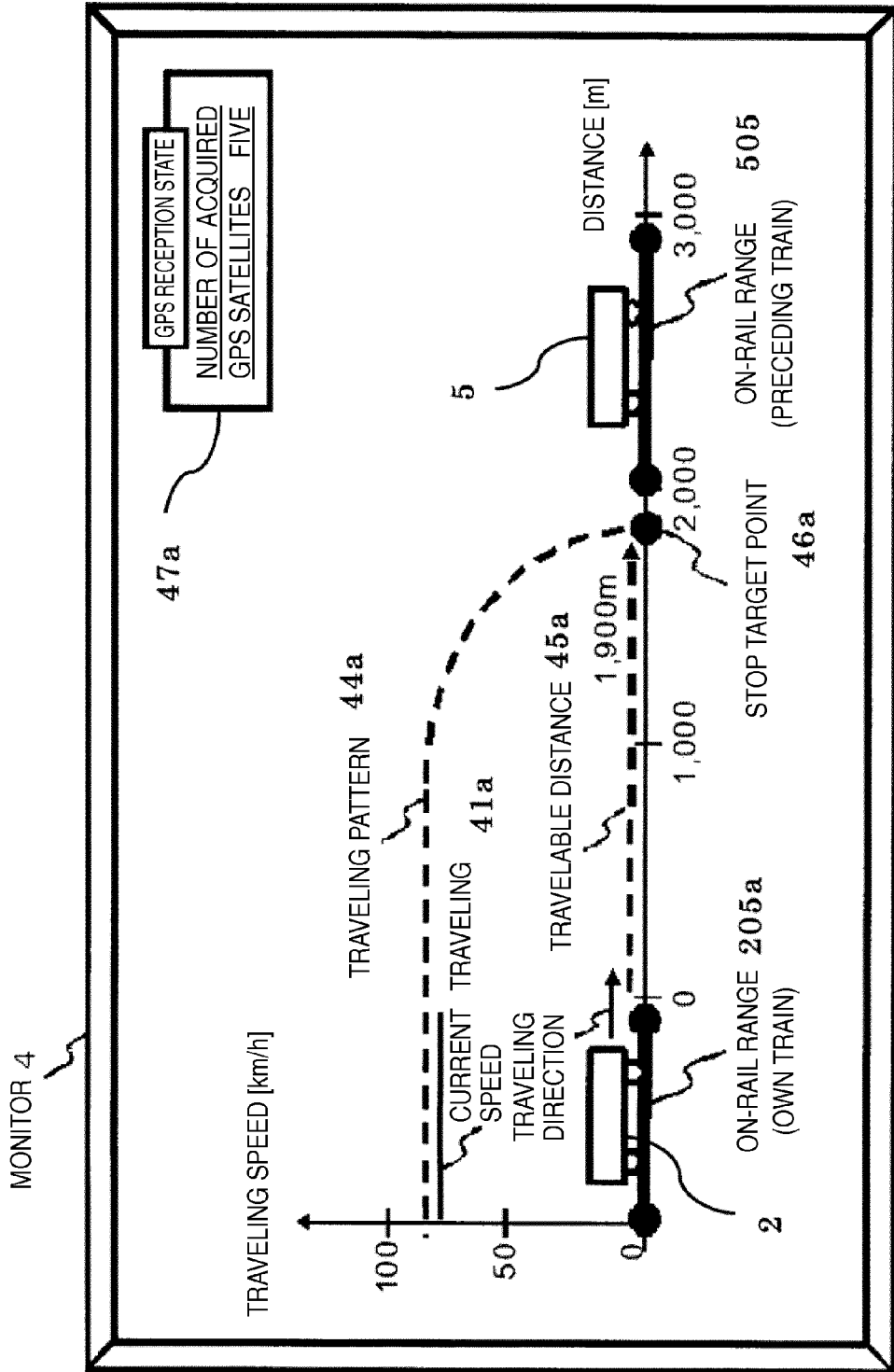

FIG. 10

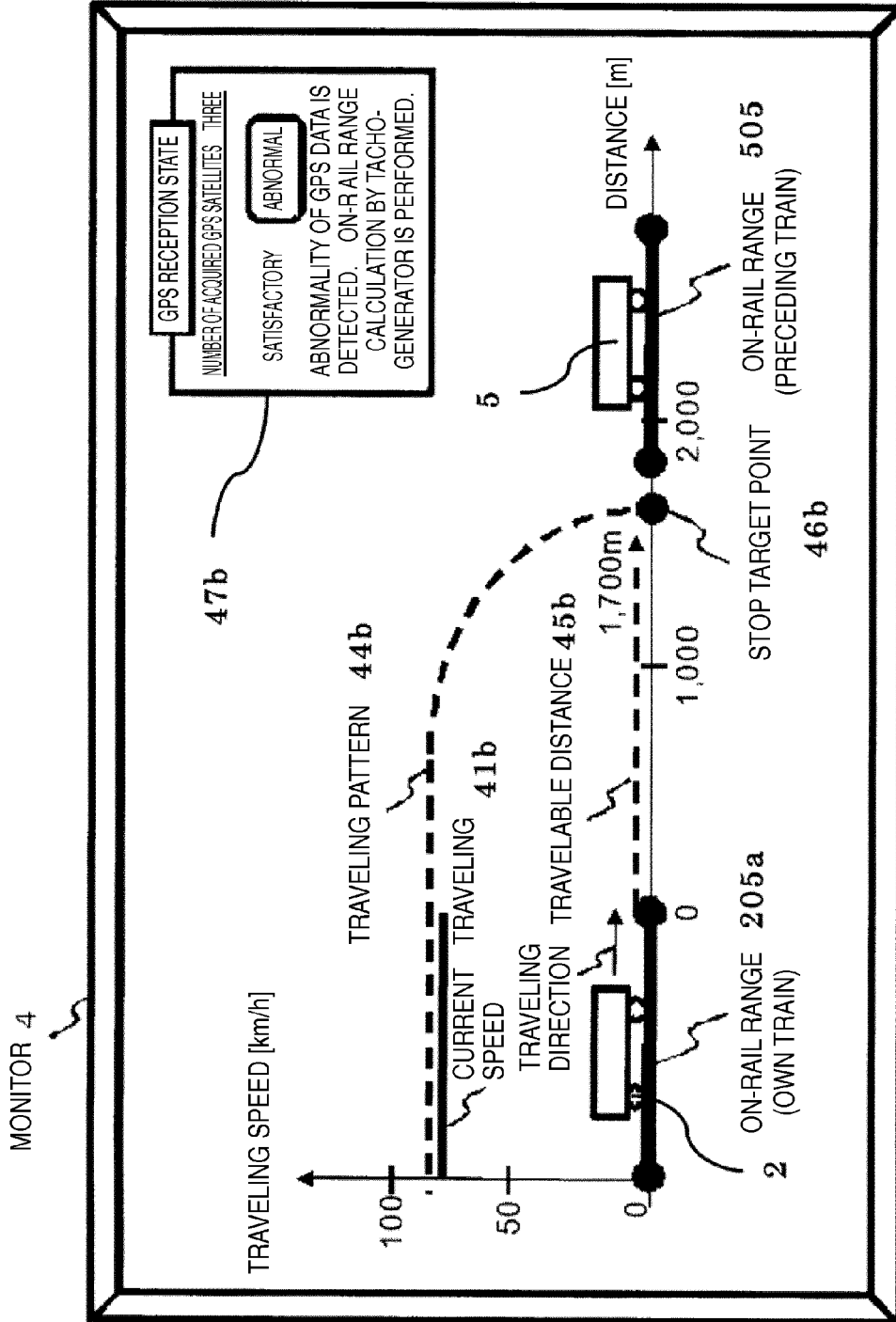
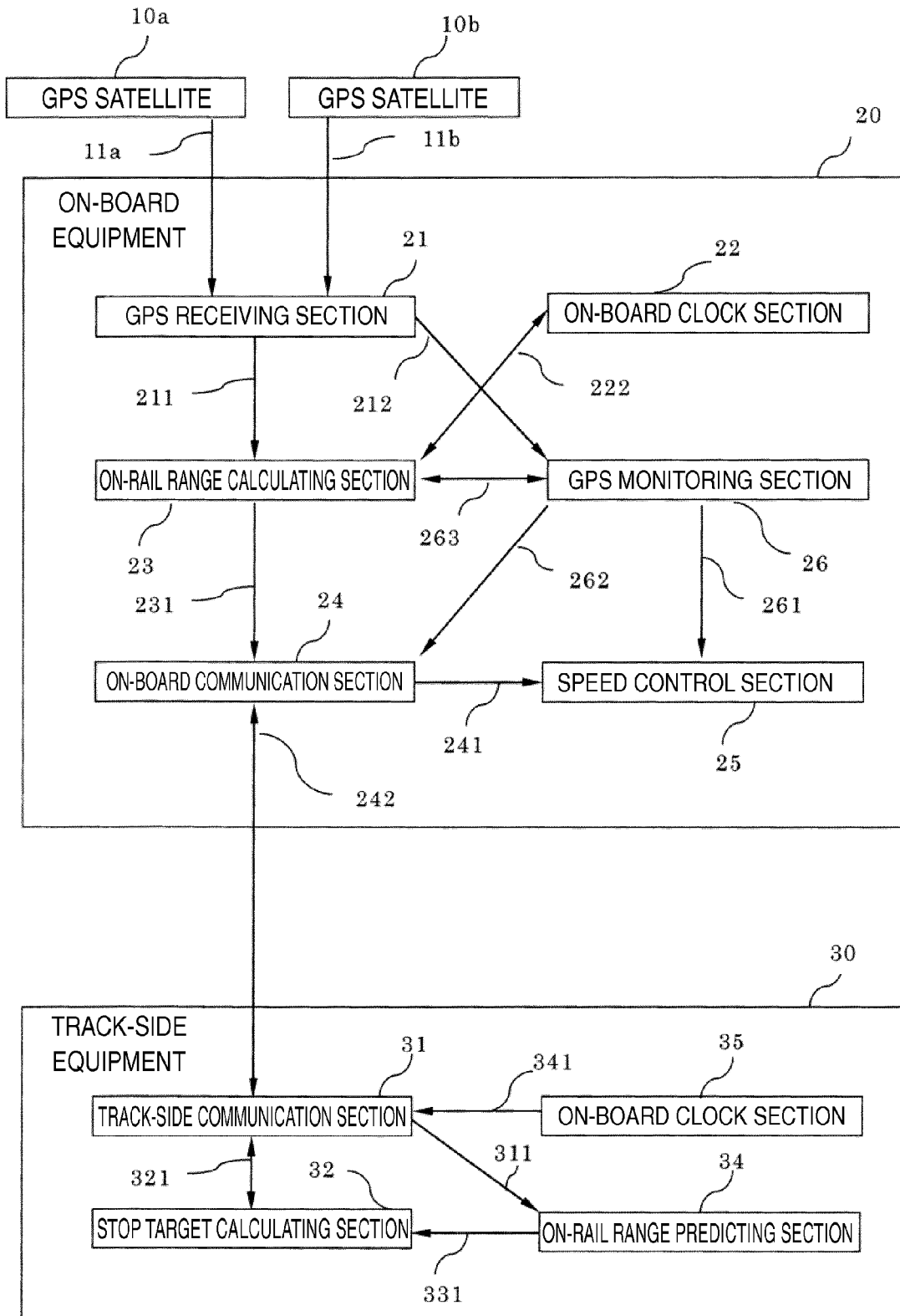

FIG. 11



REFERENCES CITED IN THE DESCRIPTION

This list of references cited by the applicant is for the reader's convenience only. It does not form part of the European patent document. Even though great care has been taken in compiling the references, errors or omissions cannot be excluded and the EPO disclaims all liability in this regard.

Patent documents cited in the description

- JP 2010120484 A [0007]