

G. T. STEPHENSON.  
 SURVEYOR'S TARGET.  
 APPLICATION FILED MAR. 5, 1908.

913,069.

Patented Feb. 23, 1909.

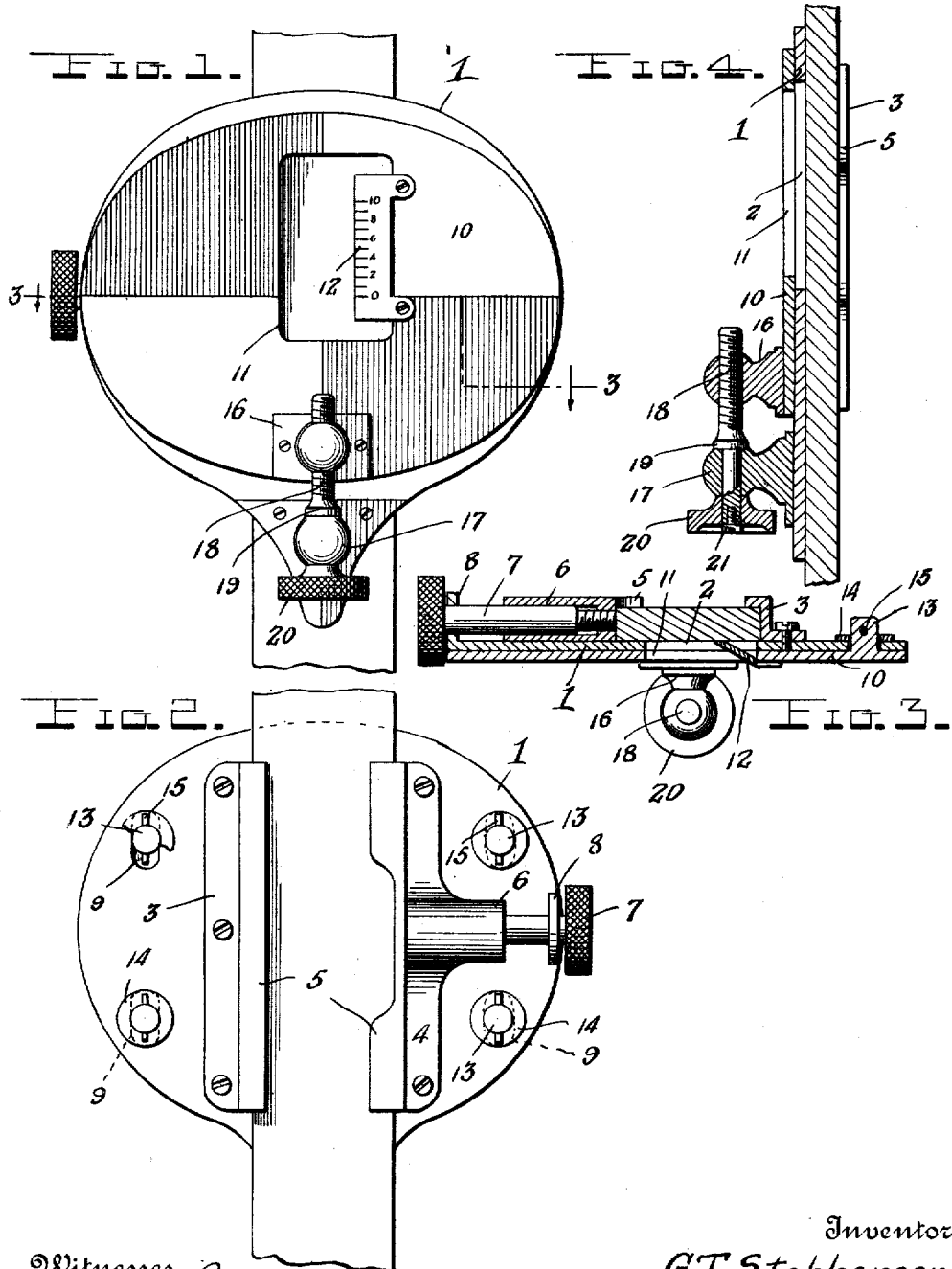

Witnesses  
 Chas. L. Friebrauer.  
 -alberta

By

G. T. Stephenson.  
 A. B. Wilson & Co.

Attorneys

# UNITED STATES PATENT OFFICE.

GRANT T. STEPHENSON, OF WELLS, MICHIGAN.

## SURVEYOR'S TARGET.

No. 913,069.

Specification of Letters Patent.

Patented Feb. 23, 1909.

Application filed March 5, 1908. Serial No. 419,369.

To all whom it may concern:

Be it known that I, GRANT T. STEPHENSON, a citizen of the United States, residing at Wells, in the county of Delta and State of Michigan, have invented certain new and useful Improvements in Surveyors' Targets; and I do declare the following to be a full, clear, and exact description of the invention, such as will enable others skilled in the art to which it appertains to make and use the same.

This invention relates to an improvement in surveyors' targets and is especially adapted for use on what is known as a Philadelphia leveling rod.

The object of the invention is to provide means for the easy and fine adjustment of the target to the divisions on the staff at a proper elevation.

With this object in view the invention consists of certain novel features of construction, combination and arrangement of parts as will be more fully described and particularly pointed out in the appended claims.

In the accompanying drawings, Figure 1 is a front elevation of a portion of a surveyor's staff with this improved target applied thereto; Fig. 2 is a rear elevation thereof with parts broken out to show the sliding connection of the two plates; Fig. 3 is a transverse section thereof; Fig. 4 is a longitudinal section.

In the embodiment illustrated a target is shown composed of an inner plate 1 having an opening 2 therein with guides arranged on opposite sides of said opening on the rear face of said plate and preferably comprising two castings 3 and 4 screwed or otherwise secured to the plate these castings being provided with inwardly extending flanges as 5 to form a guide or guides for the staff on which the target is adapted to be mounted. The casing 4 has a lateral tubular extension 6 to receive a clamping screw 7 which also extends through an apertured lug 8 carried by the plate 1. As shown this screw has a reduced screw threaded free end which operates in the bore of the extension 6 and is provided at its other end with a milled head for operating it. This plate 1 is also provided with a plurality of slots as 9 preferably four in number, two being arranged at one side of

the plate and two at the other and extending in the same direction as the guide formed by the castings 3 and 4.

The movable outer plate 10 is provided on its outer face with the ordinary colored sections used in targets of this class. This plate has also an opening 11 which registers with the opening 2 of the plate 1. Secured to one side of this opening 11 is a scale the divisions of which are designed to register with the divisions on the staff to provide for the desired adjustment of said movable plate. This plate 10 has a plurality of laterally extending studs as 13 projecting from the rear face thereof and adapted to extend through the slots as 9 in the plate 1 to guide said plate 10 in its movement relatively to the plate 1. Washers as 14 are preferably mounted on these studs outside the plate 1 and the plates are held in adjustable relation by means of pins as 15 which extend through apertures in the studs and prevent separation of the plates.

Extending from the plate 10 preferably near its lower edge is a laterally projecting member 16 preferably in the form of a ball or block having a screw threaded bore extending therethrough and in the same direction as the opening 11 in said plate. Mounted on the plate 1 adjacent to the projecting member 16 of the plate 10 is a similar member 17 having a smooth bore to receive and rotatably support a fine threaded micrometer screw 18 now to be described. One end of this screw 18 is provided with a fine thread adapted to engage the thread of the bore of the member 16 carried by the plate 10 and the other end of this screw is made smooth to rotatably fit within the bore of the member 17 carried by the plate 1. An annular shoulder 19 is formed on this screw between its threaded and unthreaded portions to serve as a stop for engaging one face of the projecting member 17 and prevent longitudinal movement of the screw in one direction. The end of this screw projects through the lower side of the member 17 is made angular to receive a milled nut 20 which is secured thereto by a screw or any other suitable means, and which is adapted to rotate the screw for moving the plate 10 slowly over the face of the plate 1 to adapt it for minute adjustment.

In the use of this target when the inner

plate 1 which affords an extended surface for frictional engagement by the outer plate 10 to provide for its slow and uniform movement thereover has been adjusted at the proper height to the staff by means of a clamping screw 7 and it is desired to move the plate 10 relatively to the plate 1 to obtain the proper adjustment, the slow moving micrometer screw 18 is turned in the desired direction to move the plate 10 either up or down as required. In fine leveling work it is very hard to move the target over minute distances without the expenditure of considerable time and trouble and by the use of this slow moving screw mounted to move one plate over the face of the other, it is possible to adjust the face of the target to minute distances with great ease.

While I have shown and described the preferred embodiment of my invention, it is to be understood that various changes in the form, proportion and the minor details of construction may be resorted to without departing from or sacrificing any of the principles of the invention within the scope of the appended claims.

I claim as my invention:—

1. A surveyor's target comprising an inner plate adapted to be fixed to a staff, an outer plate movable in guides over the face of said inner plate and in frictional contact therewith, said plates having registering openings and being approximately the same size, members extending laterally from the respective plates and having registering bores therein, the bore of the member carried by the movable plate being screw threaded, and a fine threaded micrometer screw oper-

able in said bores to move said outer plate relatively to the inner plate.

2. A surveyor's target comprising an inner plate adapted to be fixed to a staff, an outer plate movable in guides over the face of said inner plate and of approximately the same size, members extending laterally from the respective plates and having registering bores the bore of the movable plate member being screw threaded and that of the fixed member unthreaded, a fine threaded micrometer screw having an unthreaded portion rotatable in the bore of the fixed member with its threaded portion engaging the screw threaded bore of the movable plate member and means for holding said screw against longitudinal movement.

3. The combination with a surveyor's staff of a target comprising an inner plate provided with staff engaging guides to engage and fix it to said staff at any desired point, said plate having slots extending in the same direction as said guides, an outer plate having studs on its rear face projecting through the slots in the inner plate, means carried by said studs for holding said plates in operative relation and a slow moving screw rotatably mounted on said inner plate and engaging said outer plate to move it relatively to said inner plate.

In testimony whereof I have hereunto set my hand in presence of two subscribing witnesses.

GRANT T. STEPHENSON.

Witnesses:

H. H. SHEPECK,  
ED. THOMPSON.