



- (51) International Patent Classification:
H01B 1/16 (2006.01) H01B 1/06 (2006.01)
H01B 1/18 (2006.01)
- (21) International Application Number:
PCT/US2016/053202
- (22) International Filing Date:
22 September 2016 (22.09.2016)
- (25) Filing Language: English
- (26) Publication Language: English
- (30) Priority Data:
62/222,106 22 September 2015 (22.09.2015) US
- (63) Related by continuation (CON) or continuation-in-part (CIP) to earlier application:
US 14/078,489 (CIP)
Filed on 12 November 2013 (12.11.2013)
- (71) Applicant: CALIFORNIA INSTITUTE OF TECHNOLOGY [US/US]; 1200 East California Boulevard, Pasadena, California 91125 (US).
- (72) Inventors: HAJIMIRI, Seyed Ali; 1200 East California Boulevard, Pasadena, California 91125 (US). BOHN, Florian; 1200 East California Boulevard, Pasadena, California 91125 (US). ABIRI, Behrooz; 1200 East California Boulevard, Pasadena, California 91125 (US).

(74) Agents: TABIBI, Ardeshir et al.; Alston & Bird LLP, Bank of America Plaza, 101 South Tryon Street, Suite 4000, Charlotte, North Carolina 28280-4000 (US).

(81) Designated States (unless otherwise indicated, for every kind of national protection available): AE, AG, AL, AM, AO, AT, AU, AZ, BA, BB, BG, BH, BN, BR, BW, BY, BZ, CA, CH, CL, CN, CO, CR, CU, CZ, DE, DK, DM, DO, DZ, EC, EE, EG, ES, FI, GB, GD, GE, GH, GM, GT, HN, HR, HU, ID, IL, IN, IR, IS, JP, KE, KG, KN, KP, KR, KW, KZ, LA, LC, LK, LR, LS, LU, LY, MA, MD, ME, MG, MK, MN, MW, MX, MY, MZ, NA, NG, NI, NO, NZ, OM, PA, PE, PG, PH, PL, PT, QA, RO, RS, RU, RW, SA, SC, SD, SE, SG, SK, SL, SM, ST, SV, SY, TH, TJ, TM, TN, TR, TT, TZ, UA, UG, US, UZ, VC, VN, ZA, ZM, ZW.

(84) Designated States (unless otherwise indicated, for every kind of regional protection available): ARIPO (BW, GH, GM, KE, LR, LS, MW, MZ, NA, RW, SD, SL, ST, SZ, TZ, UG, ZM, ZW), Eurasian (AM, AZ, BY, KG, KZ, RU, TJ, TM), European (AL, AT, BE, BG, CH, CY, CZ, DE, DK, EE, ES, FI, FR, GB, GR, HR, HU, IE, IS, IT, LT, LU, LV, MC, MK, MT, NL, NO, PL, PT, RO, RS, SE, SI, SK, SM, TR), OAPI (BF, BJ, CF, CG, CI, CM, GA, GN, GQ, GW, KM, ML, MR, NE, SN, TD, TG).

Published:
— with international search report (Art. 21(3))



WO 2017/053631 A1

(54) Title: RF RECEIVER

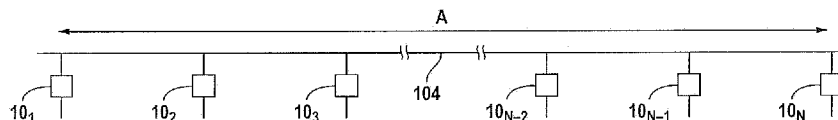

FIG. 1

(57) Abstract: A device includes, in part, an antenna adapted to receive an RF signal that includes modulated data, a splitter/coupler adapted to split the received RF signal, a receiver adapted to demodulate the data from a first portion of the RF signal, and a power recovery unit adapted to convert to a DC power a second portion of the RF signal. The splitter/coupler is optionally adjustable to split the RF signal in accordance with a value that may be representative of a number of factors, such as the target data rate, the DC power requirement of the device, and the like. The device optionally includes a switch and/or a power combiner adapted to deliver all the received RF power to the receiver depending on any number of operation conditions of the device or the device's distance from an RF transmitting device.

RF RECEIVER

CROSS-REFERENCE TO RELATED APPLICATIONS

[0001] The present application is a continuation-in-part of Application No. 14/078,489, filed November 12, 2013, entitled "Smart RF Lensing: Efficient, Dynamic And Mobile Wireless Power Transfer" which claims benefit under 35 § U.S.C 119(e) of U.S. Provisional Patent Application No. 61/724,638, filed November 9, 2012, entitled "Smart RF Lensing: Efficient, Dynamic And Mobile Wireless Power Transfer", the contents of which are incorporated herein by reference in its entirety.

[0002] The present application claims benefit under 35 § U.S.C 119(e) of U.S. Provisional Patent Application No. 62/222,106, filed September 22, 2015, entitled "Smart RF Lensing: Efficient, Dynamic And Mobile Wireless Power Transfer", the content of which is incorporated herein by reference in its entirety.

[0003] The present application is related to the following US Applications:

- Application No. 14/552,249, filed November 24, 2014, entitled "Active CMOS Recovery Units For Wireless Power Transmission";
- Application No. 14/552,414, filed November 24, 2014, entitled "Generator Unit For Wireless Power Transfer"; and
- Application No. 14/830,692, filed August 19, 2015, entitled "Wireless Power Transfer";

the contents of all of which applications are incorporated herein by reference in their entirety.

BACKGROUND OF THE INVENTION

[0004] The present invention relates to wireless communication, and more particularly to wireless power and data transfer.

BACKGROUND OF THE INVENTION

[0005] Electrical energy used in powering electronic devices comes predominantly from wired sources. Conventional wireless power transfer relies on magnetic inductive effect

between two coils placed in close proximity of one another. To increase its efficiency, the coil size is selected to be less than the wavelength of the radiated electromagnetic wave. The transferred power diminishes strongly as the distance between the source and the charging device is increased.

BRIEF SUMMARY OF THE INVENTION

[0006] An RF lens, in accordance with one embodiment of the present invention, includes, in part, a multitude of radiators adapted to radiate electromagnetic waves to power a device positioned away from the RF lens. Each of the multitude of radiators operates at the same frequency. The phase of the electromagnetic wave radiated by each of the multitude of radiators is selected to be representative of the distance between that radiator and the device.

[0007] In one embodiment, the multitude of radiators are formed in an array. In one embodiment, the array is a one-dimensional array. In another embodiment, the array is a two-dimensional array. In one embodiment, the amplitudes of the electromagnetic waves radiated by the radiators is variable. In one embodiment, each of the multitude of radiators includes, in part, a variable delay element, a control circuit adapted to lock the phase or frequency of the electromagnetic wave radiated by that radiator to the phase or frequency of a reference signal, an amplifier, and an antenna.

[0008] In one embodiment, the multitude of radiators are formed in a first radiator tile adapted to receive a second radiator tile having disposed therein another multitude of radiators. In one embodiment, the RF lens is further adapted to track a position of the device. In one embodiment, each of a first subset of the radiators includes a circuit for receiving an electromagnetic wave transmitted by the device thus enabling the RF lens to determine the position of the device in accordance with the phases of the electromagnetic wave received by the first subset of the radiators.

[0009] In one embodiment, each of at least a first subset of the radiators includes a circuit for receiving an electromagnetic wave transmitted by the device thereby enabling the RF lens to determine a position of the device in accordance with a travel time of the electromagnetic wave from the device to each of the first subset of the radiators and a travel time of a response electromagnetic wave transmitted from the RF lens to the device. In one embodiment, the RF lens is formed in a semiconductor substrate.

[0010] A method of wirelessly powering a device, in accordance with one embodiment of the present invention, includes, in part, transmitting a multitude of electromagnetic waves having the same frequency from a multitude of radiators to the device, selecting a phase of each of the multitude of radiators in accordance with a distance between that radiator and the device, and charging the device using the electromagnetic waves received by the device.

[0011] In one embodiment, the method further includes, in part, forming the radiators in an array. In one embodiment, the radiators are formed in a one-dimensional array. In another embodiment, the radiators are formed in a two-dimensional array. In one embodiment, the method further includes, in part, varying the amplitude of the electromagnetic wave radiated by each of the radiators.

[0012] In one embodiment, each radiators includes, in part, a variable delay element, a controlled locked circuit adapted to lock the phase or the frequency of the electromagnetic wave radiated by the radiator to the phase or frequency of a reference signal, an amplifier, and an antenna. In one embodiment, the radiators are formed in a first radiator tile adapted to receive a second radiator tile having disposed therein another multitude of radiators.

[0013] In one embodiment, the method further includes, in part, tracking the position of the device. In one embodiment, the method further includes, in part, determining the position of the device in accordance with relative phases of an electromagnetic wave transmitted by the device and received by each of at least a subset of the radiators. In one embodiment, the method further includes, in part, determining the position of the device in accordance with a travel time of an electromagnetic wave transmitted by the device and received by each of at least a subset of the radiators, and further in accordance with a travel time of a response electromagnetic wave transmitted from the RF lens to the device. In one embodiment, the method further includes, in part, forming the RF lens in a semiconductor substrate.

[0014] A device, in accordance with one embodiment of the present invention, includes, in part, an antenna adapted to receive an RF signal that includes modulated data, a splitter/coupler adapted to split the received RF signal into first and second portions, a receiver adapted to demodulate the data from the first portion of the received RF signal, and a power recovery unit adapted to convert the second portion of the RF signal to a DC power to power the device. In one embodiment, the splitter/coupler is an adjustable splitter/coupler

[0015] A device, in accordance with one embodiment of the present invention, includes, in part, an antenna adapted to receive an RF signal that includes modulated data, a receiver adapted to demodulate the data from a first portion of the RF signal, a power recovery unit adapted to convert a second portion of the RF signal to a DC power to power the device, and a controller adapted to receive the RF signal from the antenna and generate the first and second portions of the RF signal in accordance with impedance values of the receiver and the power recovery unit.

[0016] A device, in accordance with one embodiment of the present invention, includes, in part, an antenna adapted to receive an RF signal that includes modulated data, a switch adapted to receive the RF signal from the antenna, a power recovery unit adapted to convert the RF signal to a DC power to power the device when the switch is in a first position, and a receiver adapted to demodulate the data from the received RF signal when the switch is in a second position.

[0017] A device, in accordance with one embodiment of the present invention, includes, in part, an antenna adapted to receive an RF signal that includes modulated data, a splitter/coupler adapted to split the received RF signal into first and second portions, a switch adapted to receive the second portion of the RF signal from the splitter/coupler, a power recovery unit adapted to convert the second portion of the RF signal to a DC power to power the device when the switch is in a first position, and a power combiner adapted to receive the first portion of the RF signal from the splitter/coupler and further to receive the second portion of the RF signal when the switch is in a second position, and a receiver adapted to demodulate the data from an output signal of the power combiner. In one embodiment, the device further includes a controller adapted to cause the switch to be in the first position when a power of the received RF signal is less than a first threshold value. In one embodiment, the device further includes a controller adapted to cause the switch to be in the first position when the device indicates that its DC power exceeds a second threshold value.

[0018] A device, in accordance with one embodiment of the present invention, includes, in part, an antenna adapted to receive an RF signal that includes modulated data, a switch adapted to receive the RF signal from the antenna, a power combiner coupled to a first output terminal of the switch to receive the RF signal when the switch is in a first position, a splitter/coupler coupled to a second output terminal of the switch to receive the RF signal, when the switch is in a second position, to split the RF signal into a first portion and a second

portion and deliver the first portion of the RF signal to the power combiner, a power recovery unit adapted to convert the first portion of the RF signal to a DC power to charge the device when the switch is in the second position, and a receiver adapted to demodulate the data from an output signal of the power combiner. In one embodiment, the device further includes, in part, a controller adapted to cause the switch to be in the first position when a power of the received RF signal is less than a threshold value. In yet another embodiment, the device further includes a controller adapted to cause the switch to be in the first position when the device indicates that its DC power exceeds a threshold value.

[0019] A device, in accordance with one embodiment of the present invention, includes, in part, an antenna adapted to receive an RF signal that includes modulated data, a controller, an adjustable splitter/coupler adapted to split the received RF signal into first and second portions in accordance with a value the adjustable splitter/coupler receives from the controller, a receiver adapted to demodulate the data from the first portion of the RF signal, and a power recovery unit adapted to convert the second portion of the RF signal to a DC power to charge the device. In one embodiment, the value supplied by the controller is defined by a target data rate of the device. In another embodiment, the value supplied by the controller is defined by a DC power requirement of the device.

[0020] A method, in accordance with one embodiment of the present invention, includes, in part, receiving an RF signal that includes modulated data, splitting the received RF signal to first and second portions, demodulating the data from the first portion of the RF signal, and converting the second portion of the RF signal to a DC power.

[0021] A method, in accordance with one embodiment of the present invention, includes, in part, receiving an RF signal that includes modulated data, demodulating the data from a first portion of the received RF signal via a receiver, converting a second portion of the RF signal to a DC power via a power recovery unit, and generating the first and second portions of the RF signal in accordance with impedance values of the receiver and the power recovery unit.

[0022] A method, in accordance with one embodiment of the present invention, includes, in part, receiving an RF signal that includes modulated data, converting the RF signal to a DC power when a switch is in a first position, and demodulating the data from the received RF signal when the switch is in a second position.

[0023] A method, in accordance with one embodiment of the present invention, includes, in part, receiving an RF signal that includes modulated data, demodulating the data using either a first portion of the RF signal or the RF signal, and converting a second portion of the RF signal to a DC power when the first portion of the RF signal is used for demodulating the data. In one embodiment, the data is modulated using the RF signal when a power of the received RF signal is less than a first threshold value. In one embodiment, the data is demodulated using the RF signal when an indication is received that a battery charge exceeds a threshold value.

[0024] A device, in accordance with one embodiment of the present invention, includes, in part, an antenna adapted to receive an RF signal that includes modulated data, a controller, an adjustable splitter/coupler adapted to split the received RF signal into first and second portions in accordance with a value the adjustable splitter/coupler receives from the controller, a receiver adapted to demodulate the data from the first portion of the RF signal, and a power recovery unit adapted to convert the second portion of the RF signal to a DC power to charge the device. In one embodiment, the value supplied by the controller is defined by a target data rate of the device. In another embodiment, the value supplied by the controller is defined by a DC power requirement of the device.

[0025] A method, in accordance with one embodiment of the present invention, includes, in part, receiving an RF signal, splitting the received RF signal to first and second portions in accordance with a received value, demodulating the data from the first portion of the RF signal, and converting the second portion of the RF signal to a DC power. In one embodiment, the value is defined by a target data rate. In one embodiment, the value is defined by a DC power requirement.

BRIEF DESCRIPTION OF THE DRAWINGS

[0026] Figure 1 shows a one-dimensional array of radiators forming an RF lens, in accordance with one embodiment of the present invention.

- 5 [0027] Figure 2 is a side view of the RF lens of Figure 1 wirelessly delivering power to a device at a first location, in accordance with one exemplary embodiment of the present invention.

- [0028] Figure 3 is a side view of the RF lens of Figure 1 wirelessly delivering power to a device at a second location, in accordance with one exemplary embodiment of the present invention.
- [0029] Figure 4 is a side view of the RF lens of Figure 1 wirelessly delivering power to a device at a third location, in accordance with one exemplary embodiment of the present invention.
- [0030] Figure 5 shows a two-dimensional array of radiators forming an RF lens, in accordance with one exemplary embodiment of the present invention.
- [0031] Figure 6A is a simplified block diagram of a radiator disposed in an RF lens, in accordance with one exemplary embodiment of the present invention.
- [0032] Figure 6B is a simplified block diagram of a radiator disposed in an RF lens, in accordance with another exemplary embodiment of the present invention.
- [0033] Figure 7 shows a number of electronic components of a device adapted to be charged wirelessly, in accordance with one exemplary embodiment of the present invention.
- [0034] Figure 8 is a schematic diagram of an RF lens wirelessly charging a device, in accordance with one exemplary embodiment of the present invention.
- [0035] Figure 9 is a schematic diagram of an RF lens concurrently charging a pair of devices, in accordance with one exemplary embodiment of the present invention.
- [0036] Figure 10 is a schematic diagram of an RF lens concurrently charging a pair of mobile devices and a stationary device, in accordance with one exemplary embodiment of the present invention.
- [0037] Figure 11A shows computer simulations of the electromagnetic field profiles of a one-dimensional RF lens, in accordance with one exemplary embodiment of the present invention.
- [0038] Figure 11B is a simplified schematic view of an RF lens used in generating the electromagnetic field profiles of Figure 11A.

- [0039] Figure 12 shows the variations in computer simulated electromagnetic field profiles generated by the RF lens of Figure 11B as a function of the spacing between each adjacent pair of radiators disposed therein.
- [0040] Figure 13A is an exemplary computer-simulated electromagnetic field profile of an RF lens and using a scale of -15 dB to 0 dB, in accordance with one exemplary embodiment of the present invention.
- [0041] Figure 13B shows the computer-simulated electromagnetic field profile of Figure 13A using a scale of -45 dB to 0 dB.
- [0042] Figure 14A is an exemplary computer-simulated electromagnetic field profile of the RF lens of Figure 13A and using a scale of -15 dB to 0 dB, in accordance with one exemplary embodiment of the present invention.
- [0043] Figure 14B shows the computer-simulated electromagnetic field profile of Figure 14A using a scale of -45 dB to 0 dB, in accordance with one exemplary embodiment of the present invention.
- [0044] Figure 15A is an exemplary computer-simulated electromagnetic field profile of an RF lens and using a scale of -15 dB to 0 dB, in accordance with one exemplary embodiment of the present invention.
- [0045] Figure 15B shows the computer-simulated electromagnetic field profile of Figure 15A using a scale of -45 dB to 0 dB, in accordance with one exemplary embodiment of the present invention.
- [0046] Figure 16A is an exemplary computer-simulated electromagnetic field profile of the RF lens of Figure 15A using a scale of -15 dB to 0 dB, in accordance with one exemplary embodiment of the present invention.
- [0047] Figure 16B shows the computer-simulated electromagnetic field profile of Figure 16A using a scale of -45 dB to 0 dB, in accordance with one exemplary embodiment of the present invention.
- [0048] Figure 17A shows an exemplary radiator tile having disposed therein four radiators, in accordance with one exemplary embodiment of the present invention.

- [0049] Figure 17B shows an RF lens formed using a multitude of the radiator tiles of Figure 17A, in accordance with one exemplary embodiment of the present invention.
- [0050] Figure 18 is a simplified block diagram of a radiator disposed in an RF lens, in accordance with another exemplary embodiment of the present invention.
- 5 [0051] Figure 19 shows a number of electronic components disposed in a device adapted to be charged wirelessly, in accordance with another exemplary embodiment of the present invention.
- [0052] Figure 20 shows an RF lens tracking a device using a signal transmitted by the device, in accordance with another exemplary embodiment of the present invention.
- 10 [0053] Figure 21A is a simplified high-level block diagram of a device, in accordance with one embodiment of the present invention.
- [0054] Figure 21B is a simplified high-level block diagram of a device, in accordance with one embodiment of the present invention.
- [0055] Figure 21C is a simplified high-level block diagram of a device, in accordance with
15 one embodiment of the present invention.
- [0056] Figure 21D is a simplified high-level block diagram of a device, in accordance with one embodiment of the present invention.
- [0057] Figure 21E is a simplified high-level block diagram of a device, in accordance with one embodiment of the present invention.
- 20 [0058] Figure 21F is a simplified high-level block diagram of a device, in accordance with one embodiment of the present invention.
- [0059] Figure 22 shows an RF lens transferring power to a device in the presence of a multitude of scattering objects, in accordance with another exemplary embodiment of the present invention.
- 25 [0060] Figure 23A shows an RF lens formed using a multitude of radiators arranged in a circular shape, in accordance with one embodiment of the present invention.
- [0061] Figure 23B shows an RF lens formed using a multitude of radiators arranged in an elliptical shape, in accordance with one embodiment of the present invention.

DETAILED DESCRIPTION OF THE INVENTION

[0062] An RF lens, in accordance with one embodiment of the present invention, includes a multitude of radiators adapted to transmit radio frequency electromagnetic EM waves
5 (hereinafter alternatively referred to as EM waves, or waves) whose phases and amplitudes are modulated so as to concentrate the radiated power in a small volume of space (hereinafter alternatively referred to as focus point or target zone) in order to power an electronic device positioned in that space. Accordingly, the waves emitted by the radiators are caused to interfere constructively at the focus point. Although the description below is provided with
10 reference to wireless power transfer, the following embodiments of the present invention may be used to transfer any other kind of information wirelessly.

[0063] Figure 1 shows a multitude of radiators, arranged in an array 100, forming an RF lens, in accordance with one embodiment of the present invention. Array 100 is shown as including N radiators $10_1, 10_2, 10_3 \dots 10_{N-1}, 10_N$ each adapted to radiate an EM wave whose
15 amplitude and phase may be independently controlled in order to cause constructive interference of the radiated EM waves at a focus point where a device to be charged is located, where N is integer greater than 1. Figure 2 is a side view of the array 100 when the relative phases of the waves generated by radiators 10_i (i is an integer ranging from 1 to N) are selected so as to cause constructive interference between the waves to occur near region
20 102 where a device being wirelessly charged is positioned, i.e., the focus point. Region 102 is shown as being positioned at approximately distance d_1 from center 104 of array 100. The distance between the array center and the focus point is alternatively referred to herein as the focal length. Although the following description of an RF lens is provided with reference to a
25 one or two dimensional array of radiators, it is understood that an RF lens in accordance with the present invention may have any other arrangement of the radiators, such as a circular arrangement 1000 of radiators 202 as shown in Figure 22A, or the elliptical arrangement 1010 of radiators 202 shown in Figure 22B.

[0064] As seen from Figure 2, each radiator 10_i is assumed to be positioned at distance y_i from center 104 of array 100. The amplitude and phase of the wave radiated by radiator 10_i
30 are assumed to be represented by A_i and θ_i respectively. Assume further that the wavelength of the waves being radiated is represented by λ . To cause the waves radiated by the radiators

to interfere constructively in region 102 (i.e., the desired focus point), the following relationship is satisfied between various phases θ_i and distances y_i :

$$\theta_1 + \frac{2\pi}{\lambda} \sqrt{d_1^2 + y_1^2} = \theta_2 + \frac{2\pi}{\lambda} \sqrt{d_1^2 + y_2^2} = \dots = \theta_N + \frac{2\pi}{\lambda} \sqrt{d_1^2 + y_N^2}$$

5

[0065] Since the phase of an RF signal may be accurately controlled, power radiated from multiple sources may be focused, in accordance with the present invention, onto a target zone where a device to be wirelessly charged is located. Furthermore, dynamic phase control enables the tracking of the device as it moves from its initial location. For example, as shown in Figure 3, if the device moves to a different position—along the focal plane—located at a distance d_2 from center point 104 of the array, in order to ensure that the target zone is also located at distance d_2 , the phases of the sources may be adjusted in accordance with the following relationship:

$$15 \quad \theta_1 + \frac{2\pi}{\lambda} \sqrt{d_2^2 + y_1^2} = \theta_2 + \frac{2\pi}{\lambda} \sqrt{d_2^2 + y_2^2} = \dots = \theta_N + \frac{2\pi}{\lambda} \sqrt{d_2^2 + y_N^2} \quad (1)$$

[0066] Referring to Fig. 4, if the device moves to a different position away from the focal plane (e.g., to a different point along the y -axis) the radiators' phases are dynamically adjusted, as described below, so as to track and maintain the target zone focused on the device. Parameter y_c represents the y -component of the device's new position, as shown in Figure 4, from the focal plane of the array (i.e, the plane perpendicular to the y -axis and passing through center 104 of array 100).

$$25 \quad \theta_1 + \frac{2\pi}{\lambda} \sqrt{d_2^2 + (y_1 - y_c)^2} = \theta_2 + \frac{2\pi}{\lambda} \sqrt{d_2^2 + (y_2 - y_c)^2} = \dots = \theta_N + \frac{2\pi}{\lambda} \sqrt{d_2^2 + (y_N - y_c)^2} \quad (2)$$

[0067] The amount of power transferred is defined by the wavelength λ of the waves being radiated by the radiators, the array span or array aperture A as shown in Figure 1, and the focal length, i.e. ($\lambda F/A$).

30

[0068] In one embodiment, the distance between each pair of radiators is of the order of the wavelength of the signal being radiated. For example, if the frequency of the radiated wave is 2.4 GHz (i.e., the wavelength is 12.5 cm), the distance between each two radiators may be a few tenths to a few tens of the wavelengths, that may vary depending on the application.

5 [0069] An RF lens, in accordance with the present invention, is operative to transfer power wirelessly in both near-field and far field regions. In the optical domain, a near field region is referred to as the Fresnel region and is defined as a region in which the focal length is of the order of the aperture size. In the optical domain, a far field region is referred to as the Fraunhofer region and is defined as a region in which the focal length (F) is substantially
10 greater than $(2A^2/\lambda)$.

[0070] To transfer power wirelessly to a device, in accordance with the present invention, the radiator phases are selected so as to account for differences in distances between the target point and the radiators. For example, assume that the focal length d_1 in Figure 2 is of the order of the aperture size A . Therefore, since distances $S_1, S_2, S_3, \dots, S_N$ are different from
15 one another, corresponding phases $\theta_1, \theta_2, \theta_3, \dots, \theta_N$ of radiators $10_1, 10_2, 10_3, \dots, 10_N$ are varied so as to satisfy expression (1), described above. The size of the focus point (approximately $\lambda F/A$) is relatively small for such regions because of the diffraction limited length.

[0071] A radiator array, in accordance with the present invention, is also operative to transfer power wirelessly to a target device in the far field region where the focal length is
20 greater than $(2A^2/\lambda)$. For such regions, the distances from the different array elements to the focus spot are assumed to be the same. Accordingly, for such regions, $S_1 = S_2 = S_3, \dots, S_N$, and $\theta_1 = \theta_2 = \theta_3, \dots, \theta_N$. The size of the focus point is relatively larger for such regions and thus is more suitable for wireless charging of larger appliances.

[0072] Figure 5 shows an RF lens 200, in accordance with another embodiment of the
25 present invention. RF lens 200 is shown as including a two dimensional array of radiators $202_{i,j}$ arranged along rows and columns. Although RF lens 200 is shown as including 121 radiators $202_{i,j}$ disposed along 11 rows and 11 columns (integers i and j are indices ranging from 1 to 11) it is understood that an RF lens in accordance with embodiments of the present invention may have any number of radiators disposed along U rows and V columns, where U
30 and V are integers greater one. In the following description, radiators $202_{i,j}$ may be collectively or individually referred to as radiators 202.

[0073] As described further below, the array radiators are locked to a reference frequency, which may be a sub-harmonic ($n=1, 2, 3 \dots$) of the radiated frequency, or at the same frequency as the radiated frequency. The phase of the wave radiated by each radiator are controlled independently in order to enable the radiated waves to constructively interfere and concentrate their power onto a target zone within any region in space.

[0074] Figure 6A is a simplified block diagram of a radiator 202 disposed in RF lens 200, in accordance with one embodiment of the present invention. As seen, radiator 202 is shown as including, in part, a programmable delay element (also referred to herein as phase modulator) 210, a phase/frequency locked loop 212, a power amplifier 214, and an antenna 216. Programmable delay element 210 is adapted to delay signal W_2 to generate signal W_3 . The delay between signals W_2 and W_3 is determined in accordance with control signal Ctrl applied to the delay element. In one embodiment, phase/frequency locked loop 212 receives signal W_1 as well as a reference clock signal having a frequency F_{ref} to generate signal W_2 whose frequency is locked to the reference frequency F_{ref} . In another embodiment, signal W_2 generated by phase/frequency locked loop 212 has a frequency defined by a multiple of the reference frequency F_{ref} . Signal W_3 is amplified by power amplifier 214 and transmitted by antenna 216. Accordingly and as described above, the phase of the signal radiated by each radiator 202 may be varied by an associated programmable delay element 210 disposed in the radiator.

[0075] Figure 6B is a simplified block diagram of a radiator 202 disposed in RF lens 200, in accordance with another embodiment of the present invention. As seen, radiator 202 is shown as including, in part, a programmable delay element 210, a phase/frequency locked loop 212, a power amplifier 214, and an antenna 216. Programmable delay element 210 is adapted to delay the reference clock signal F_{ref} thereby to generate a delayed reference clock signal F_{ref_Delay} . The delay between signals F_{ref} and F_{ref_Delay} is determined in accordance with control signal Ctrl applied to the delay element 210. Signal W_2 generated by phase/frequency locked loop 212 has a frequency locked to the frequency of signal F_{ref_Delay} or a multiple of the frequency of signal F_{ref_Delay} . In other embodiments (not shown), the delay element is disposed in and is part of phase/frequency locked loop 212. In yet other embodiments (not shown), the radiators may not have an amplifier.

[0076] Figure 7 shows a number of components of a device 300 adapted to be charged wirelessly, in accordance with one embodiment of the present invention. Device 300 is shown as including, in part, an antenna 302, a rectifier 304, and a regulator 306. Antenna 302 receives the electromagnetic waves radiated by a radiator, in accordance with the present invention. Rectifier 304 is adapted to convert the received AC power to a DC power. Regulator 306 is adapted to regulate the voltage signal received from rectifier 304 and apply the regulated voltage to the device. High power transfer efficiency is obtained, in one embodiment, if the aperture area of the receiver antenna is comparable to the size of the target zone of the electromagnetic field. Since most of the radiated power is concentrated in a small volume forming the target zone, such a receiver antenna is thus optimized to ensure that most of the radiated power is utilized for charging up the device. In one embodiment, the device may be retro-fitted externally with components required for wireless charging. In another embodiment, existing circuitry present in the charging device, such as antenna, receivers, and the like, may be used to harness the power.

[0077] Figure 8 is a schematic diagram of RF lens 200 wirelessly charging device 300. In some embodiments, RF lens 200 wirelessly charges multiple devices concurrently. Figure 9 shows RF lens 200 concurrently charging devices 310, and 315 using focused waves of similar or different strengths. Figure 10 shows RF lens 200 wireless charging mobile devices 320, 325 and stationary device 330 all of which are assumed to be indoor.

[0078] Figure 11A shows computer-simulated electromagnetic field profiles generated by a one-dimensional RF lens at a distance 2 meters away from the RF lens having an array of 11 isotropic radiators. The beam profiles are generated for three different frequencies, namely 200 MHz (wavelength 150 cm), 800 MHz (wavelength 37.5 cm), and 2400 MHz (wavelength 12.5 cm). Since the distance between each pair of adjacent radiators of the RF lens is assumed to be 20 cm, the RF lens has an aperture of 2 m. Therefore, the wavelengths are of the order of aperture size and focal length of the radiator. Figure 11B is a simplified schematic view of such an RF lens 500 having 11 radiators 505_k that are spaced 20 cm apart from one another, where K is an integer ranging from 1 to 11.

[0079] Plots 510, 520 and 530 are computer simulations of the electromagnetic field profiles respectively for 200 MHz, 800 MHz, and 2400 signals radiated by radiator 500 when the relative phases of the various radiators are selected so as to account for the path

differences from each of radiators 505_k to the point located 2 meters away from radiator 505₆ in accordance with expression (1) above. For each of these profiles, the diffraction limited focus size is of the order of the wavelengths of the radiated signal. Plots 515, 525 and 535 are computer simulations of the electromagnetic field profiles at a distance 2 meters away from the radiator array for 200 MHz, 800 MHz, and 2400 signals respectively when the phases of radiators 505_k were set equal to one another.

[0080] As seen from these profiles, for the larger wavelength having a frequency of 200 MHz (i.e, plots 510, 515), because the path differences from the individual radiators to the focus point are not substantially different, the difference between profiles 510 and 515 is relatively unpronounced. However, for each of 800 MHz and 2400 MHz frequencies, the EM confinement (focus) is substantially more when the relative phases of the various radiators are selected so as to account for the path differences from the radiators 505_k to the focus point than when radiator phases are set equal to one another. Although the above examples are provided with reference to operating frequencies of 200 MHz, 800 MHz, and 2400 MHz, it is understood that the embodiments of the present may be used in any other operating frequency, such as 5.8 GHz, 10 GHz, and 24 GHz.

[0081] Figure 12 shows the variations in computer simulated electromagnetic field profiles generated by RF lens 500—at a distance of 2 meters away from the RF lens—as a function of the spacing between each adjacent pair of radiators. The RF lens is assumed to operate at a frequency of 2400 MHz. Plots 610, 620, and 630 are computer simulations of the field profiles generated respectively for radiator spacings of 5 cm, 10 cm, and 20 cm after selecting the relative phases of the various radiators to account for the path differences from various radiators 505_k to the point 2 meters away from the RF lens, in accordance with expression (1) above. Plots 615, 625, and 650 are computer simulations of the field profiles generated respectively for radiator spacings of 5 cm, 10 cm, and 20 cm assuming all radiators disposed in RF lens 500 have equal phases. As is seen from these plots, as the distance between the radiators increases—thus resulting in a larger aperture size—the EM confinement also increases thereby resulting in a smaller focus point.

[0082] Figure 13A is the computer simulation of the EM profile of an RF lens at a distance 3 meters away from an RF lens having disposed therein a two-dimensional array of Hertzian dipoles operating at a frequency of 900 MHz, such as RF lens 200 shown in Figure 5. The

spacing between the dipole radiators are assumed to be 30 cm. The relative phases of the radiators were selected so as to account for the path differences from the radiators to the focal point, assumed to be located 3 meters away from the RF lens. In other words, the relative phases of the radiators is selected to provide the RF lens with a focal length of approximately 3 meters. The scale used in generating Figure 13A is -15 dB to 0 dB. Figure 13B shows the EM profile of Figure 13A using a scale of -45 dB to 0 dB.

[0083] Figure 14A is the computer simulation of the EM profile of the RF lens of Figures 13A/13B at a distance 2 meters away from the focal point, i.e., 5 meters away from the RF lens. As is seen from Figure 14A, the radiated power is diffused over a larger area compared to those shown in Figures 13A and 13B. The scale used in generating Figure 14A is -15 dB to 0 dB. Figure 14B shows the EM profile of Figure 14A using a scale of -45 dB to 0 dB.

[0084] Figure 15A is the computer simulation of the EM profile of an RF lens at a distance 3 meters away from the RF lens having disposed therein a two-dimensional array of Hertzian dipoles operating at a frequency of 900 MHz. The spacing between the dipole radiators are assumed to be 30 cm. The relative phases of the radiators are selected so as to account for the path differences from the radiators to the focal point, assumed to be located 3 meters away from the RF lens and at an offset of 1.5 m from the focal plane of the RF lens, i.e., the focus point has a y-coordinate of 1.5 meters from the focal plane (see Figure 4). The scale used in generating Figure 15A is -15 dB to 0. Figure 15B shows the EM profile of Figure 15A using a scale of -45 dB to 0 dB.

[0085] Figure 16A is the computer simulation of the EM profile of the RF lens of Figures 15A/15B at a distance 2 meters away from the focal point, i.e., 5 meters away from the x-y plane of the RF lens. As is seen from Figure 16A, the radiated power is diffused over a larger area compared to that shown in Figure 15A. The scale used in generating Figure 16A is -15 dB to 0 dB. Figure 16B shows the EM profile of Figure 16A using a scale of -45 dB to 0 dB. The EM profiles shown in Figures 13A, 13B, 14A, 14B 15A, 15B, 16A, 16B demonstrate the versatility of an RF lens, in accordance with the present invention, in focusing power at any arbitrary point in 3D space.

[0086] In accordance with one aspect of the present invention, the size of the array forming an RF lens is configurable and may be varied by using radiator tiles each of which may include one or more radiators. Figure 17A shows an example of a radiator tile 700 having

disposed therein four radiators 15₁₁, 15₁₂, 15₂₁, and 15₂₂. Although radiator tile 700 is shown as including four radiators, it is understood that a radiator tile, in accordance with one aspect of the present invention, may have fewer (e.g., one) or more than (e.g., 6) four radiators. Figure 17B shown an RF lens 800 initially formed using 7 radiator tiles, namely radiator tiles 5 700₁₁, 700₁₂, 700₁₃, 700₂₁, 700₂₂, 700₃₁, 700₃₂—each of which is similar to radiator tile 700 shown in Figure 17A—and being provided with two more radiator tiles 700₂₃ and 700₃₃. Although not shown, it is understood that each radiator tile includes the electrical connections necessary to supply power to the radiators and deliver information from the radiators as necessary. In one embodiment, the radiators formed in the tiles are similar to radiator 202 10 shown in Figure 6.

[0087] In accordance with one aspect of the present invention, the RF lens is adapted to track the position of a mobile device in order to continue the charging process as the mobile device changes position. To achieve this, in one embodiment, a subset or all of the radiators forming the RF lens include a receiver. The device being charged also includes a transmitter 15 adapted to radiate a continuous signal during the tracking phase. By detecting the relative differences between the phases (arrival times) of such a signal by at least three different receivers formed on the RF lens, the position of the charging device is tracked.

[0088] Figure 18 is a simplified block diagram of a radiator 902 disposed in an RF lens, such as RF lens 200 shown in Figure 5, in accordance with one embodiment of the present 20 invention. Radiator 902 is similar to radiator 202 shown in Figure 6, except that radiator 902 has a receiver amplifier and phase recovery circuit 218, and a switch S₁. During power transfer, switch S₁ couples antenna 216 via node A to power amplifier 214 disposed in the transmit path. During tracking, switch S₁ couples antenna 216 via node B to receiver amplifier and phase recovery circuit 218 disposed in the receive path to receive the signal 25 transmitted by the device being charged.

[0089] Figure 19 shows a number of components of a device 900 adapted to be charged wirelessly, in accordance with one embodiment of the present invention. Device 900 is similar to device 300 shown in Figure 7, except that device 900 has a transmit amplifier 316, and a switch S₂. During power transfer, switch S₂ couples antenna 302 via node D to rectifier 304 disposed in receive path. During tracking, switch S₂ couples antenna 302 via node C to 30 transmit amplifier 316 to enable the transmission of a signal subsequently used by the RF

lens to detect the position of device 300. Figure 20 shows RF lens 200 tracking device 900 by receiving the signal transmitted by device 900.

[0090] A radiator, in accordance with any of the embodiments of the present invention, in addition to transferring RF power to a device wirelessly, may also wirelessly transfer
5 modulated data to such a device. For example, a radiator, in accordance with the embodiments of the present invention, may operate as a wireless local area network (WLAN) router to direct signal power toward other such routers or receivers (WLAN or otherwise) to increase the received signal power by orders of magnitude and thereby increase the range, coverage and wireless data rates, as well as reduce the effect of multi-path propagation of the
10 RF signal and power. Transferring wireless signal and/or power, in accordance with embodiments of the present invention and in conformity with any communication standards, such as WiFi, Zigbee, Bluetooth, GSM, GPRS, Edge, and UMTS, to a receiving device, and tracking the location of the device as it moves through physical space, greatly increases the range of the data link and achievable data rates.

15 [0091] Because the power levels required for data transmission are typically orders of magnitude lower than the power levels for wireless power transfer, in accordance with embodiments of the present invention, both power and data transmission may be performed concurrently. In other words, for any given amount of emitted power by a generation unit, in accordance with embodiments of the present invention, the range of wireless power transfer
20 is smaller than the range for wireless data transmission. Therefore, a device that is in range for wireless power transfer, is also in range for wireless data transmission. Furthermore, the amount of power siphoned off in detecting the transmitted data signal is typically much smaller compared to the power available for concurrently powering the device. In addition, a device that may be charged wirelessly can also operate over the relatively narrow range of
25 frequencies around the center frequency spanned by most signal modulation schemes used in data transmission.

[0092] Figure 21A is a simplified high-level block diagram of a device 750 (e.g., cellular phone, camera, wearable device, toy), in accordance with one embodiment of the present invention. Device 750 is shown as including, in part, an antenna 760, a directional power
30 splitter/coupler (alternatively referred to herein as coupler) 752, a power recovery unit 754, and a radio signal receiver/demodulator (alternatively referred to herein as receiver) 756.

Antenna 760 is adapted to receive a signal from a radiator or an array of radiators, as described for example above, and deliver the received signal to coupler 752. The signal received by the antenna is a modulated signal that carries information/data as well as RF power, both of which are transmitted using the same frequency. Coupler 752 is adapted to transfer a first portion of the received RF signal to receiver 756 and a second portion of the received signal to power recovery unit 754. Receiver 756 demodulates the received signal to recover the transmitted data. Power recovery unit 754 is adapted to convert the received RF signal to a DC power to power device 750 or charge device 750's battery. Although not shown, it is understood that device 750 may use filters and/or transistors instead of coupler 752 to distribute the received RF power between power recovery unit 754 and receiver 756. US Application No. 14/552,249, filed November 24, 2014, entitled "Active CMOS Recovery Units For Wireless Power Transmission", the content of which is incorporated herein by reference in its entirety, describes in detail various embodiments of power recovery unit 754. In one embodiment, directional coupler/splitter 752 is adjustable (via a controller not shown in Figure 21A) that can vary the split ratio so as to change the amount of power coupler/splitter 752 provides to receiver 756 relative to the power it provides to power recovery unit 754.

[0093] Figure 21B is a simplified high-level block diagram of a device 755, in accordance with one embodiment of the present invention. Device 755 is shown as including, in part, an antenna 760, a controller 762, a power recovery unit 754, and a radio signal receiver/demodulator (hereinafter receiver) 756. Antenna 760 is adapted to receive a signal from a radiator or an array of radiators, as described above, and deliver the received signal to controller 762. Controller 762 is adapted to distribute the received RF power in accordance with an inverse ratio of the impedances of receiver 756 and power recovery unit 754. Controller 762 may be further adapted to vary the impedances seen at its output terminals such that the output impedance having a closer value to the impedance seen at the input of controller 762 receives a higher amount of the received RF power.

[0094] Figure 21C is a simplified high-level block diagram of a device 760, in accordance with another embodiment of the present invention. Device 760 is similar to device 750 except that device 760 uses a switch 764 in place of coupler 752. When switch 764 is in position P₁, all of the received RF power is delivered to power recovery unit 754 thereby to charge device 760. When switch 764 is in position P₂, all of the received RF power is delivered to receiver

756 to receive the transmitted data. For example, if device 760 is determined as being out-of-range for wireless power charging, switch 764 is placed in position P₂ to supply all of the received wireless power to receiver 756 to improve, e.g., its signal to noise ratio. Likewise, if device 760 is detected as being within range but requiring no additional charge, switch 764 is placed in position P₂ to supply all of the received wireless power to receiver 756. If, for example, data reception is not of interest, switch 764 is placed in position P₁ to supply all of the received RF power to power recovery unit 754.

[0095] For example, assume that an RF lens or a radiator array (a power generating unit) broadcasts an RF signal to determine if the received RF signal is strong enough to wirelessly charge a device receiving the RF signal. If the received RF signal is detected as not being strong enough to wirelessly charge the device, a controller (not shown in Figure 21C) controlling switch 764 may switch to radio receiving mode by placing switch 764 to position P₂. Once in the radio receiving mode, the device may then communicate with the radiator array to enable the radiator array to focus its RF power on the device. After the radiator array focuses its transmitted RF signal on device 760, thereby causing the received RF signal to be sufficient for wireless charging, the controller may place switch 764 in position P₁ to enable power recovery unit 754 to charge device 760. When device 760 is charged to a sufficient level, it may so inform the controller thus causing switch 764 to be placed in switch position P₂. It is understood that any number of conditions and criteria may be used to change the position of switch 764.

[0096] Figure 21D is a simplified high-level block diagram of a device 765, in accordance with another embodiment of the present invention. Device 765 is shown as including, in part, an antenna 760, a coupler 752, a switch 764, a power combiner 758, a power recovery unit 754, and a receiver 756. Antenna 760 is adapted to receive a modulated signal that carries information as well as RF power, both of which are transmitted using the same frequency. Coupler 752 is adapted to transfer a first portion of the received RF signal to power combiner 758, and a second portion of the received signal to switch 764. When switch 764 is position P₁, (i) the first portion of the power supplied by coupler 752 is delivered to receiver 756 via power combiner 758, and (ii) the second portion of the power supplied by coupler 752 is delivered to power recovery unit 754 to wirelessly charge device 765. Receiver 756 demodulates the received signal to recover the transmitted data.

[0097] When switch 764 is position P_2 , power combiner 758 combines the first portion of the power it receives from coupler 752 with the second portion of power it receives from switch 764 and delivers the combined power to receiver 756. Accordingly, in such embodiments, receiver 756 continues to receive the transmitted RF signal regardless of the switch position. For example, when the received RF power is detected as being below a threshold value, switch 764 is placed in position P_2 (via a controller not shown) so that all the received RF power is used for signal reception. When the received RF power is detected as being above a threshold value and/or device 765 requests to be charged, switch 764 is placed in position P_1 (via the controller) so that a relatively small fraction of the received RF power is used for signal detection by receiver 756, and the remainder of the RF power is used by power recovery unit 754 to charge device 765.

[0098] Figure 21E is a simplified high-level block diagram of a device 775, in accordance with another embodiment of the present invention. Device 775 is shown as including, in part, an antenna 760, a coupler 752, a switch 764, a power combiner 758, a power recovery unit 754, and a receiver 756. Antenna 760 is adapted to receive a modulated signal that carries information/data as well as RF power, both of which are transmitted using the same frequency. Receiver 756 demodulates the received signal to recover the transmitted data.

[0099] When switch 764 is position P_2 , the received RF signal is supplied to directional coupler 752, which in turn, delivers (i) a first portion of the received power to receiver 756 via power combiner 758, and (ii) a second portion of the received power to power recovery unit 754 for wirelessly charging device 775. When switch 764 is in position P_1 , substantially all of the received RF power is delivered to receiver 756 via power combiner 758. Accordingly, device 775 is adapted to continuously deliver the RF signal to receiver 756.

[0100] Figure 21F is a simplified high-level block diagram of a device 785, in accordance with another embodiment of the present invention. Device 785 is shown as including, in part, an antenna 760, an adjustable power splitter/coupler 782, a control unit 762, a power recovery unit 754, and a receiver 756. Antenna 760 is adapted to receive a modulated signal that carries information as well as RF power, both of which are transmitted using the same frequency. Adjustable power splitter/coupler 782 is adapted to split the RF signal it receives from antenna 760 into first and second portions in accordance with a split ratio adjustable power splitter/coupler 782 receives from control unit 762. The split ratio supplied by control

unit 762 may be defined by any number of factors, such as the target data rate set by receiver 756, the DC power requested by the power recovery unit 754, the power requested by receiver 756, and the like.

[0101] Referring to Figures 21A-21E, it is understood that power combiner 758 may be formed using any arrangement or configuration of active and/or passive devices capable of combining power from two or more sources. Typical examples include lossless power combiners such as coupled transmission lines, their lumped circuit equivalent using capacitors or inductors, magnetic transformers, and other circuits, as is well known. Directional coupler 752 may include coupled transmission lines, transformers and/or their lumped circuit equivalent. Switch 764 adapted to switch RF power may include pass gates, electronically tunable impedance networks, relays and the like, as is also well known.

[0102] In accordance with another embodiment of the present invention, a pulse based measurement technique is used to track the position of the mobile device. To achieve this, one or more radiators forming the RF lens transmit a pulse during the tracking phase. Upon receiving the pulse, the device being tracked sends a response which is received by the radiators disposed in the array. The travel time of the pulse from the RF lens to the device being tracked together with the travel times of the response pulse from the device being tracked to the RF lens is representative of the position of the device being tracked. In the presence of scatterers, the position of the device could be tracked using such estimation algorithms as maximum likelihood, or least-square, Kalman filtering, a combination of these techniques, or the like. The position of the device may also be determined and tracked using WiFi and GPS signals.

[0103] The presence of scattering objects, reflectors and absorbers may affect the RF lens' ability to focus the beam efficiently on the device undergoing wireless charging. For example, Figure 22 shows an RF lens 950 transferring power to device 300 in the presence of a multitude of scattering objects 250. To minimize such effects, the amplitude and phase of the individual radiators of the array may be varied to increase power transfer efficiency. Any one of a number of techniques may be used to vary the amplitude or phase of the individual radiators.

[0104] In accordance with one such technique, to minimize the effect of scattering, a signal is transmitted by one or more of the radiators disposed in the RF lens. The signal(s) radiated

- from the RF lens is scattered by the scattering objects and received by the radiators (see Fig 18). An inverse scattering algorithm is then used to construct the scattering behavior of the environment. Such a construction may be performed periodically to account for any changes that may occur with time. In accordance with another technique, a portion or the entire
- 5 radiator array may be used to electronically beam-scan the surroundings to construct the scattering behavior from the received waves. In accordance with yet another technique, the device undergoing wireless charging is adapted to periodically send information about the power it receives to the radiator. An optimization algorithm then uses the received information to account for scattering so as to maximize the power transfer efficiency.
- 10 **[0105]** In some embodiments, the amplitude/phase of the radiators or the orientation of the RF lens may be adjusted to take advantage of the scattering media. This enable the scattering objects to have the proper phase, amplitude and polarization in order to be used as secondary sources of radiation directing their power towards the device to increase the power transfer efficiency.
- 15 **[0106]** The above embodiments of the present invention are illustrative and not limitative. Embodiments of the present invention are not limited by number of radiators disposed in an RF lens, nor are they limited by the number of dimensions of an array used in forming the RF lens. Embodiments of the present invention are not limited by the type of radiator, its frequency of operation, and the like. Embodiments of the present invention are not limited
- 20 by the type of device that may be wirelessly charged. Embodiments of the present invention are not limited by the type of substrate, semiconductor, flexible or otherwise, in which various components of the radiator may be formed. Other additions, subtractions or modifications are obvious in view of the present disclosure and are intended to fall within the scope of the appended claims.

WHAT IS CLAIMED IS:

1. A device comprising:
 - an antenna adapted to receive an RF signal comprising modulated data;
 - a splitter/coupler coupled to the antenna and adapted to split the received RF signal into first and second portions;
 - a receiver adapted to demodulate the data from the first portion of the RF signal; and
 - a power recovery unit adapted to convert the second portion of the RF signal to a DC power to power the device.

2. A device comprising:
 - an antenna adapted to receive an RF signal comprising modulated data;
 - a receiver adapted to demodulate the data from a first portion of the RF signal;
 - a power recovery unit adapted to convert a second portion of the RF signal to a DC power to power the device; and
 - a controller adapted to receive the RF signal from the antenna and generate the first and second portions of the RF signal in accordance with impedance values of the receiver and the power recovery unit.

3. A device comprising:
 - an antenna adapted to receive an RF signal comprising modulated data;
 - a switch adapted to receive the RF signal from the antenna;
 - a power recovery unit adapted to convert the RF signal to a DC power to power the device when the switch is in a first position; and
 - a receiver adapted to demodulate the data from the received RF signal when the switch is in a second position.

4. A device comprising:
 - an antenna adapted to receive an RF signal comprising modulated data;
 - a splitter/coupler coupled to the antenna and adapted to split the received RF signal into first and second portions;
 - a switch adapted to receive the second portion of the RF signal from the splitter/coupler;

a power recovery unit adapted to convert the second portion of the RF signal to a DC power to power the device when the switch is in a first position; and

a power combiner adapted to receive the first portion of the RF signal from the splitter/coupler and further to receive the second portion of the RF signal when the switch is in a second position; and

a receiver adapted to demodulate the data from an output signal of the power combiner.

5. A device comprising:

an antenna adapted to receive an RF signal comprising modulated data;

a switch coupled to the antenna to receive the RF signal therefrom;

a power combiner coupled to a first output terminal of the switch to receive the RF signal when the switch is in a first position;

a splitter/coupler coupled to a second output terminal of the switch to receive the RF signal when the switch is in a second position, said splitter adapted to split the RF signal into a first portion and a second portion, said splitter/coupler delivering the first portion of the RF signal to the power combiner;

a power recovery unit adapted to convert the second portion of the RF signal to a DC power to charge the device when the switch is in the second position;

a receiver adapted to demodulate the data from an output signal of the power combiner.

6. The device of claim 5 further comprising:

a controller adapted to cause the switch to be in the first position when a power of the received RF signal is less than a threshold value.

7. The device of claim 5 further comprising:

a controller adapted to cause the switch to be in the first position when the device indicates that its DC power exceeds a threshold value.

8. The device of claim 4 further comprising:

a controller adapted to cause the switch to be in the first position when a power of the received RF signal is less than a first threshold value.

9. The device of claim 4 further comprising:

a controller adapted to cause the switch to be in the first position when the device indicates that its DC power exceeds a second threshold value.

10. A method comprising:
receiving an RF signal comprising modulated data;
splitting the received RF signal into first and second portions;
demodulating the data from the first portion of the RF signal; and
converting the second portion of the RF signal to a DC power.

11. A method comprising:
receiving an RF signal comprising modulated data;
demodulating the data from a first portion of the received RF signal via a receiver;
converting a second portion of the RF signal to a DC power via a power recovery unit;
generating the first and second portions of the RF signal in accordance with impedance values of the receiver and the power recovery unit

12. A method comprising:
receiving an RF signal comprising modulated data;
converting the RF signal to a DC power when a switch is in a first position;
and
demodulating the data from the received RF signal when the switch is in a second position.

13. A method comprising:
receiving an RF signal comprising modulated data;
demodulating the data using either a first portion of the received RF signal or the received RF signal; and
converting a second portion of the RF signal to a DC power when the first portion of the RF signal is used for demodulating the data.

14. The method of claim 13 further comprising:
demodulating the data using the received RF signal when a power of the received RF signal is less than a first threshold value.

15. The method of claim 14 further comprising:
demodulating the data using the received RF signal when an indication is received that a battery charge exceeds a threshold value.
16. A device comprising:
an antenna adapted to receive an RF signal comprising modulated data;
a controller;
an adjustable splitter/coupler adapted to split the received RF signal into first and second portions in accordance with a value said adjustable splitter/coupler receives from the controller;
a receiver adapted to demodulate the data from the first portion of the RF signal; and
a power recovery unit adapted to convert the second portion of the RF signal to a DC power to power the device.
17. The device of claim 16 wherein said value is defined by a target data rate.
18. The device of claim 16 wherein said value is defined by a DC power requirement of the device.
19. A method comprising:
receiving an RF signal;
splitting the received RF signal into first and second portions in accordance with a received value;
demodulating the data from the first portion of the RF signal; and
converting the second portion of the RF signal to a DC power.
20. The method of claim 19 wherein said value is defined by a target data rate.
21. The device of claim 16 wherein said value is defined by a DC power requirement.

22. The device of claim 1 wherein said splitter/coupler is an adjustable splitter/coupler.

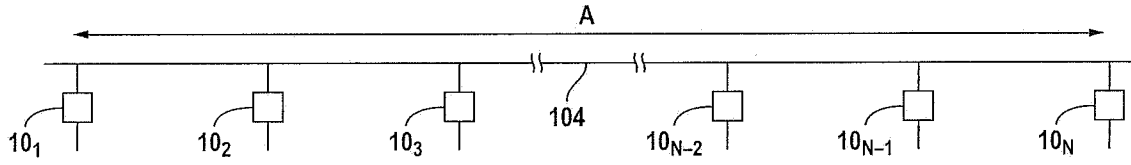

FIG. 1

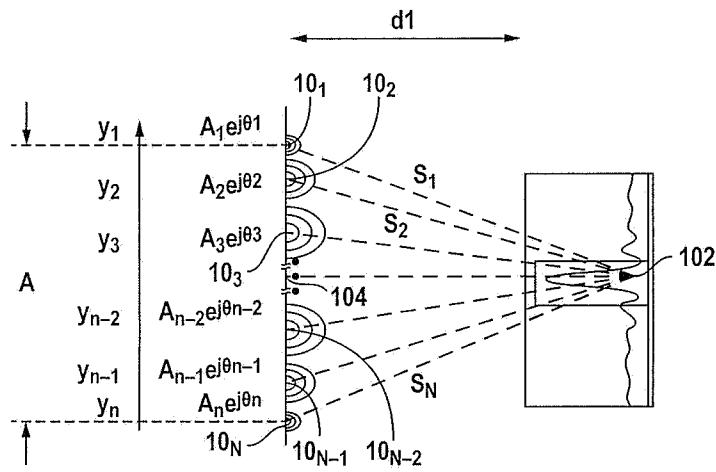

FIG. 2

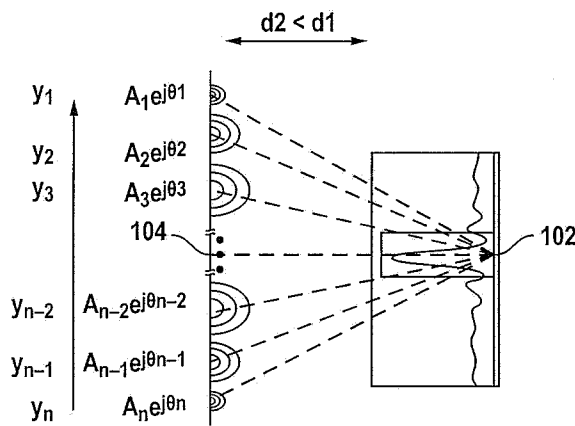

FIG. 3

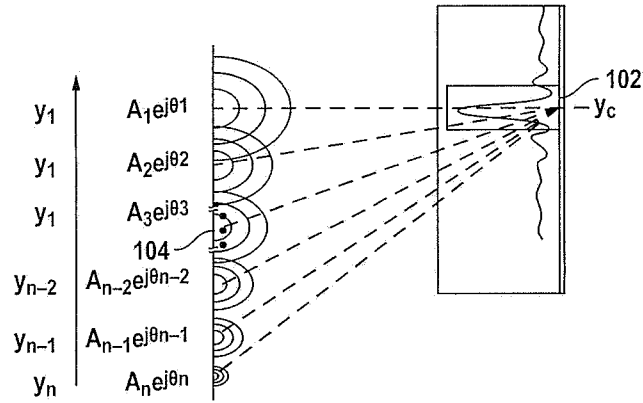

FIG. 4

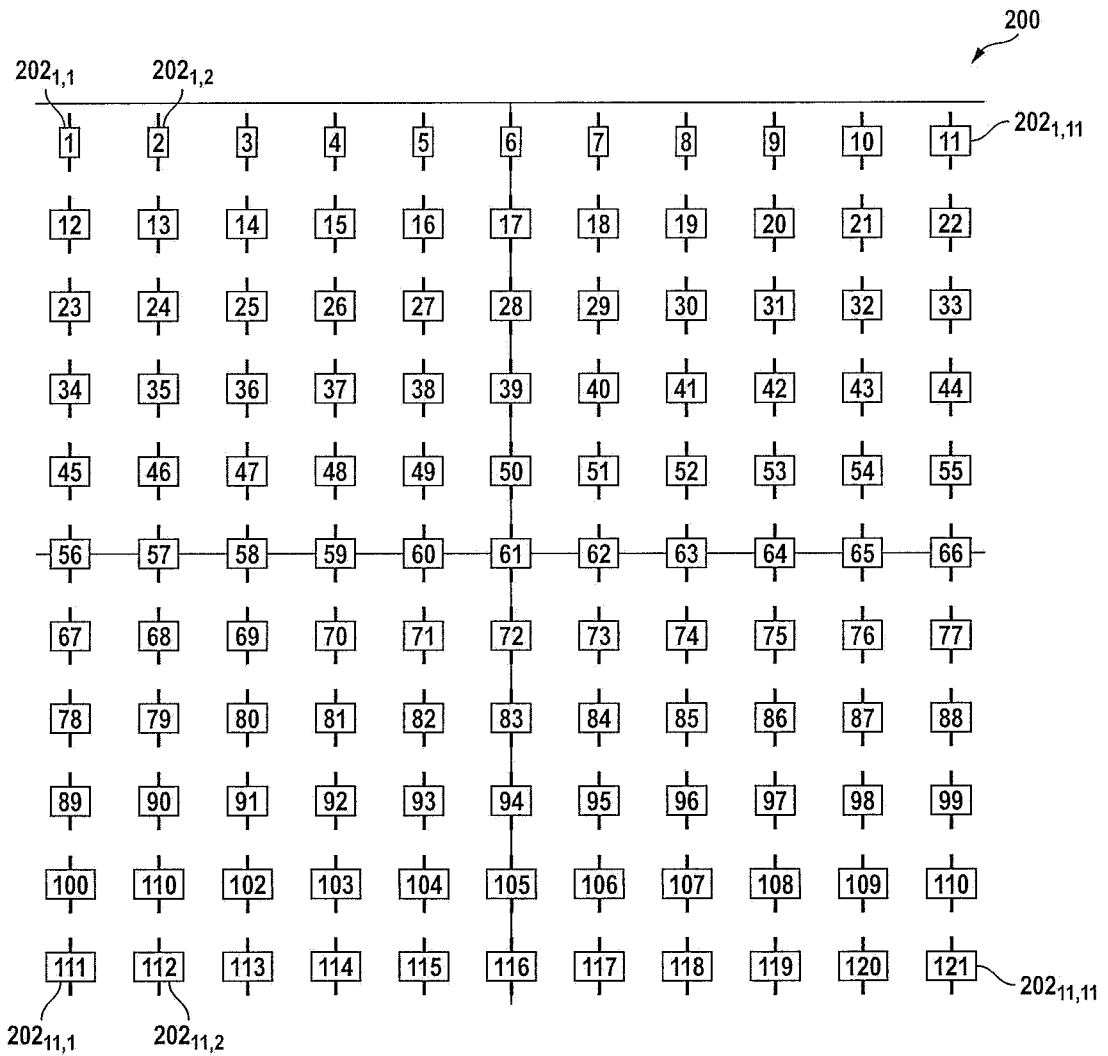

FIG. 5

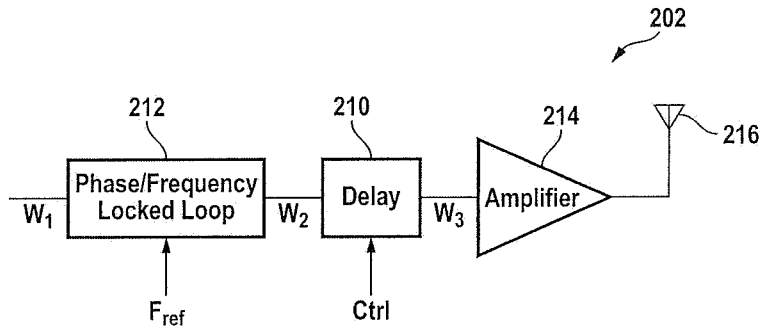

FIG. 6A

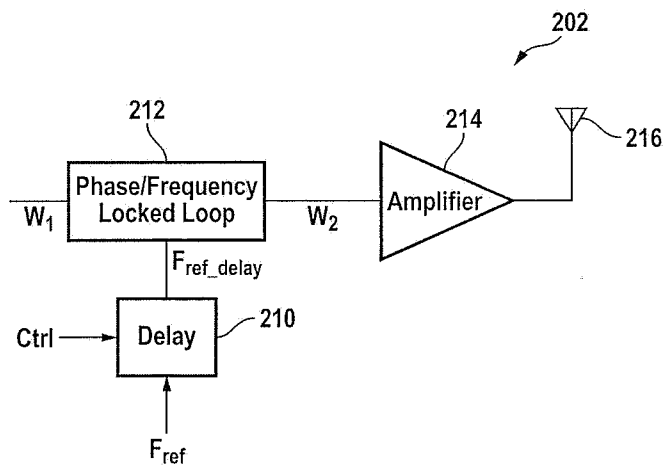

FIG. 6B

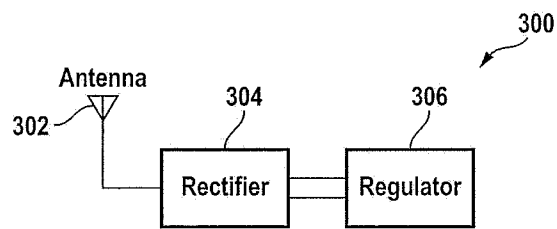

FIG. 7

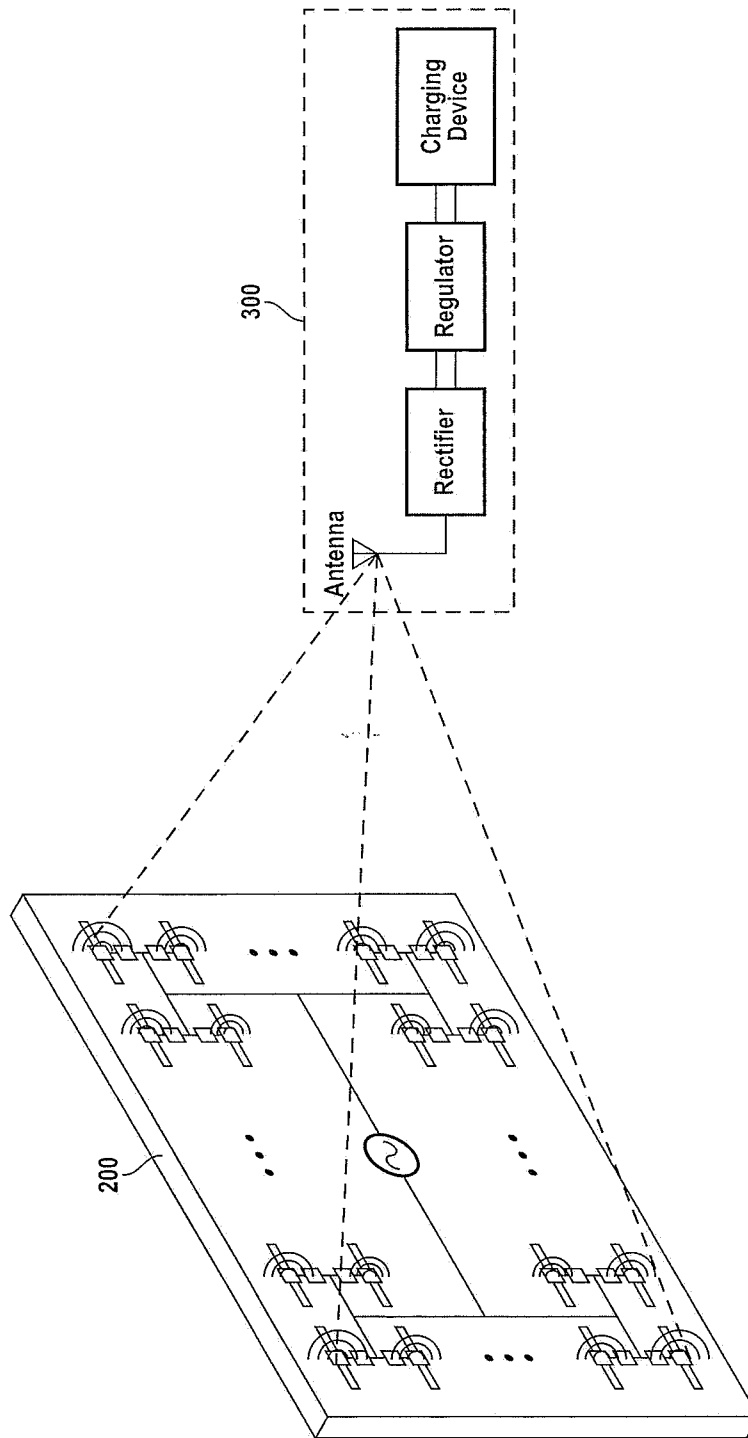

FIG. 8

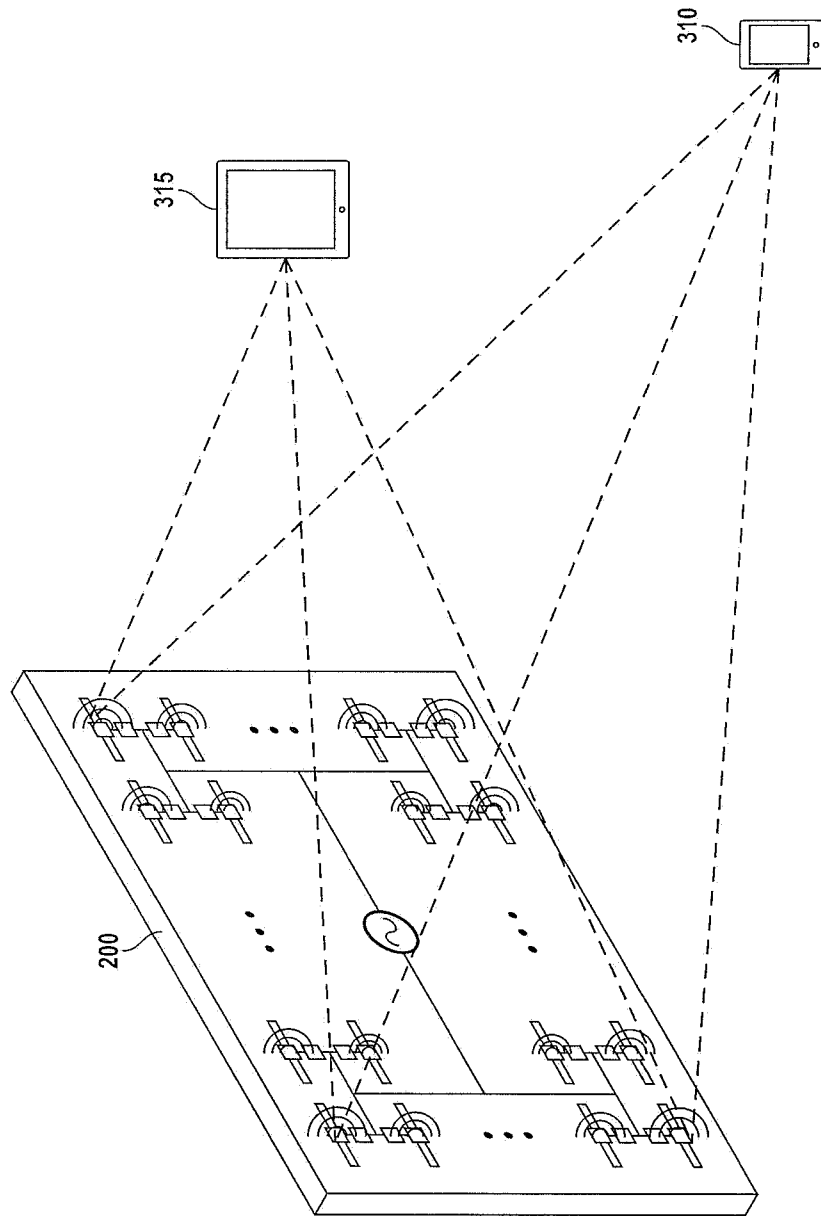

FIG. 9

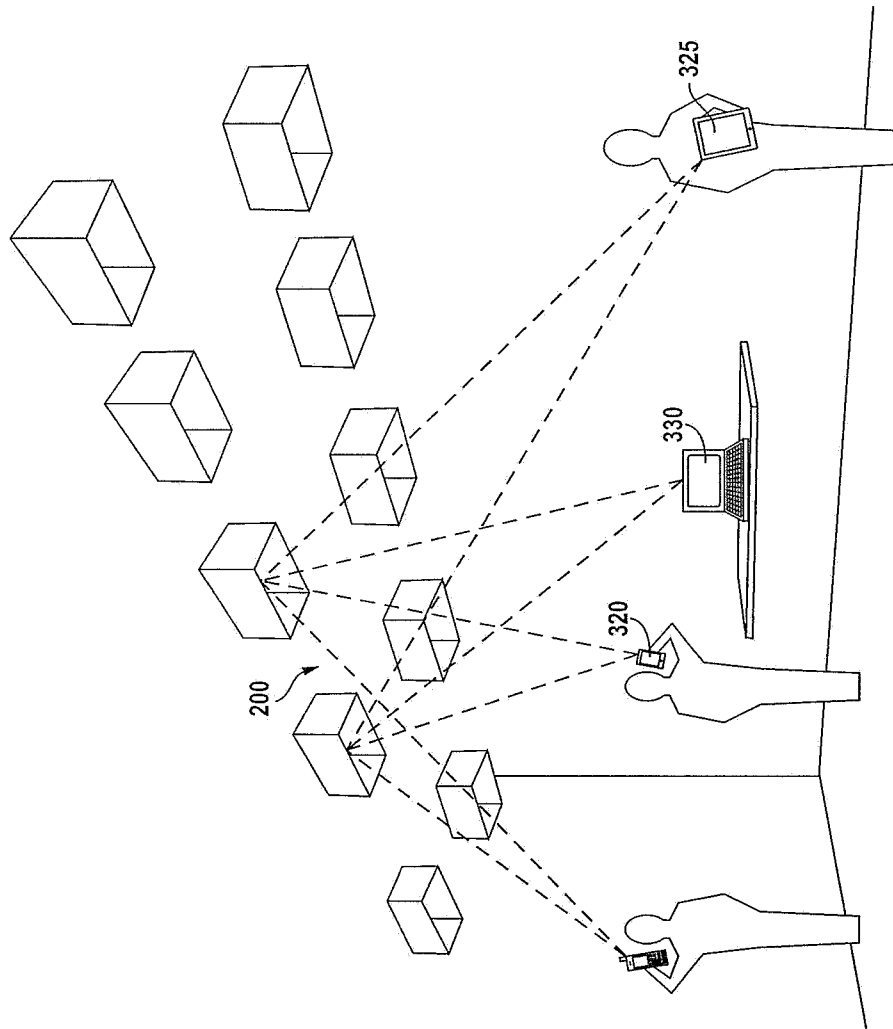

FIG. 10

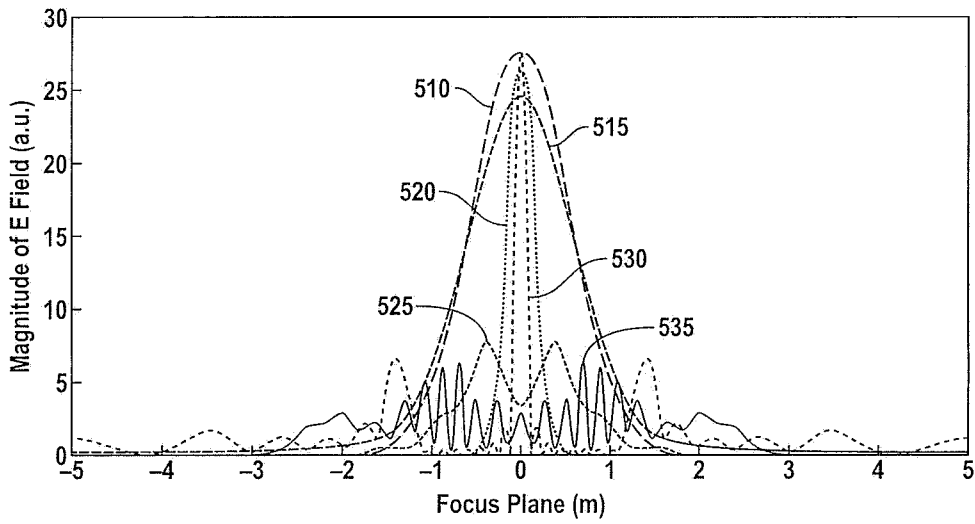

FIG. 11A

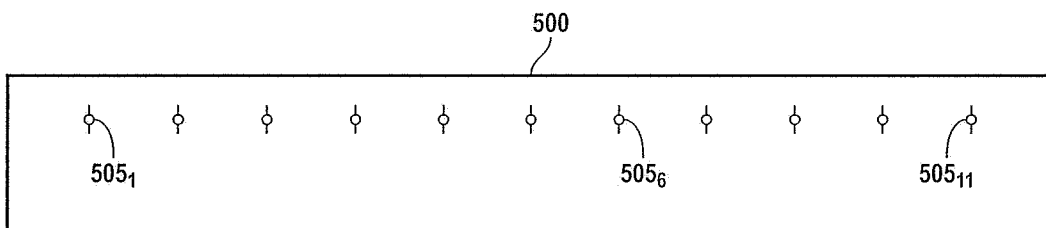

FIG. 11B

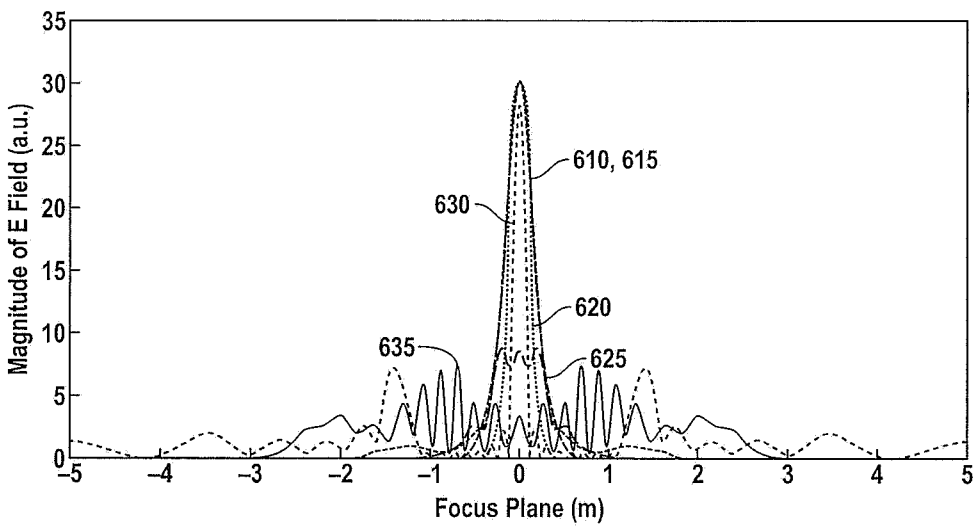

FIG. 12

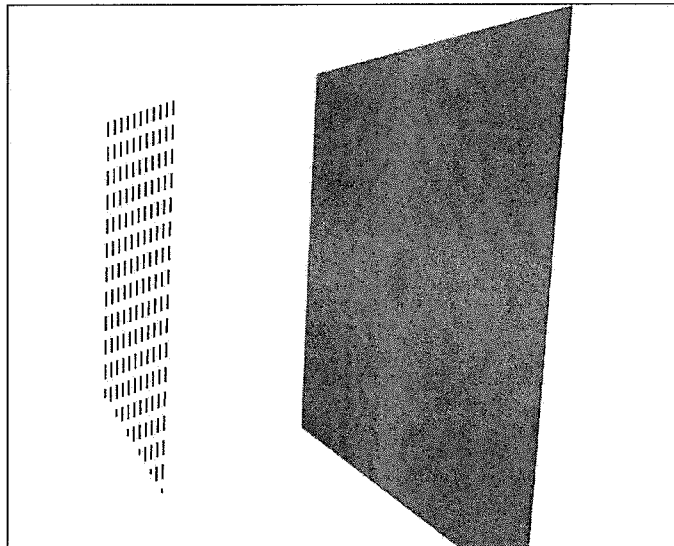

FIG. 13A

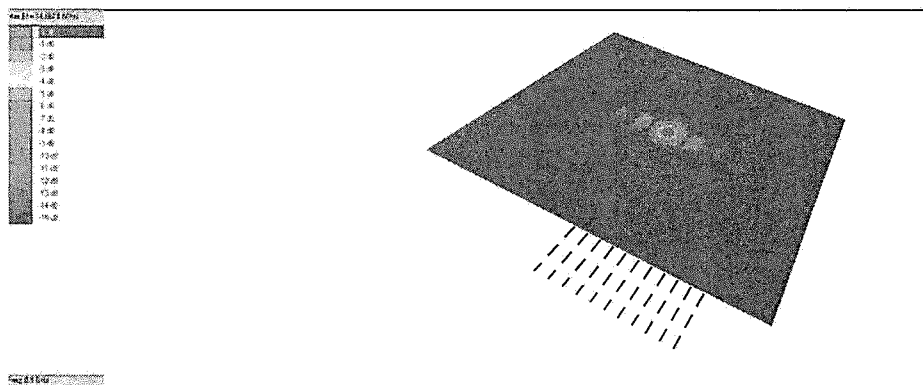

FIG. 13B

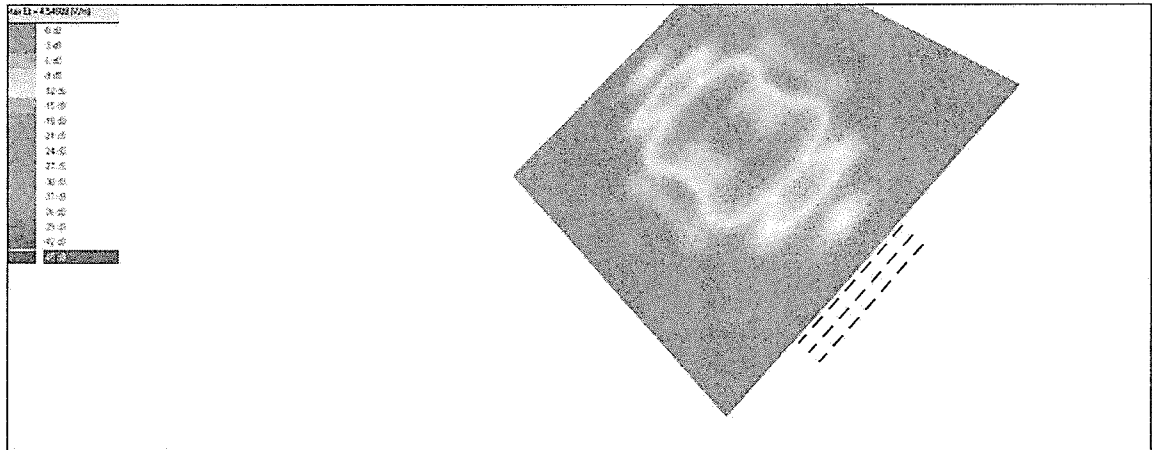

FIG. 14A

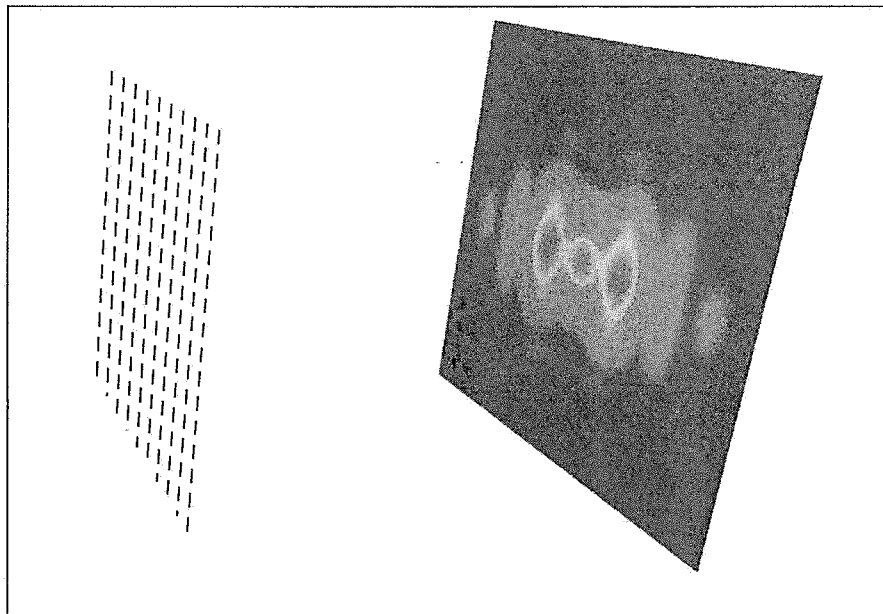

FIG. 14B

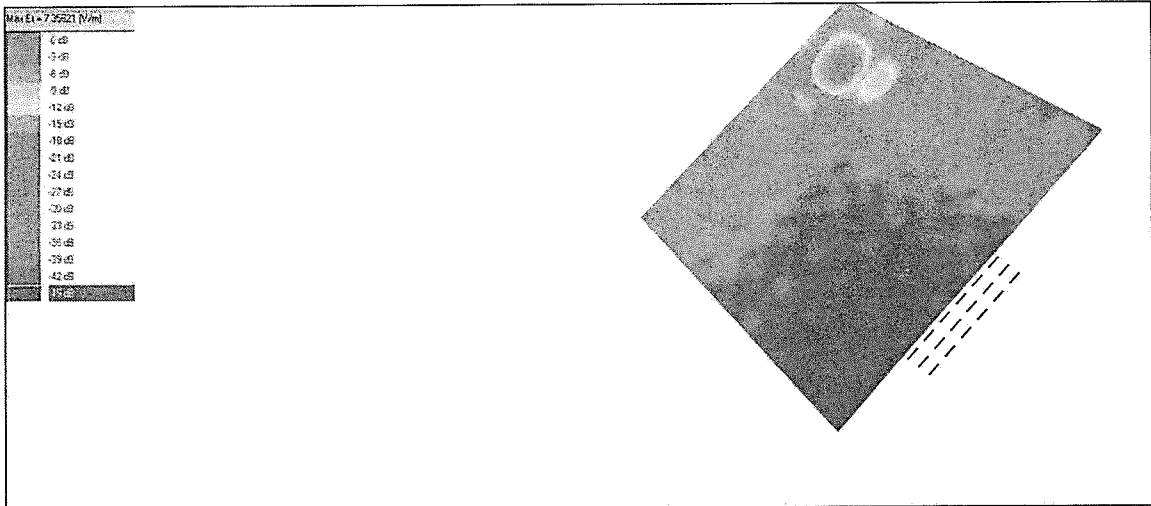

FIG. 15A

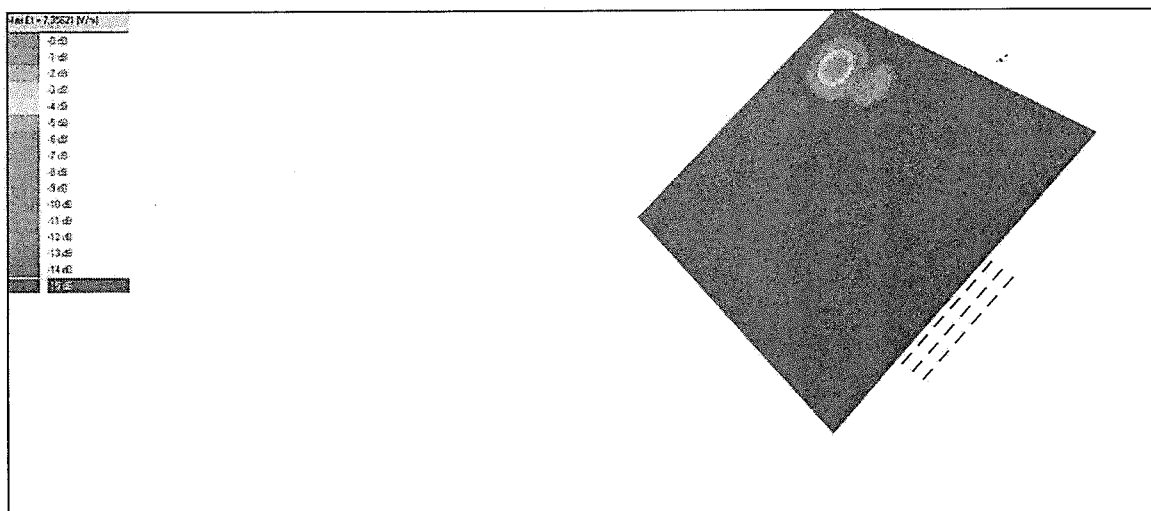

FIG. 15B

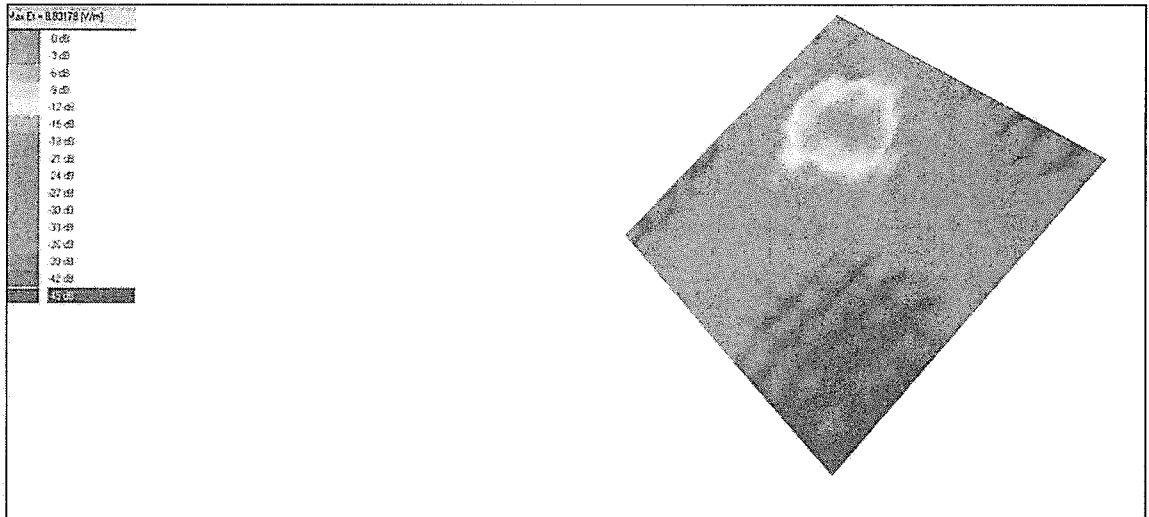

FIG. 16A

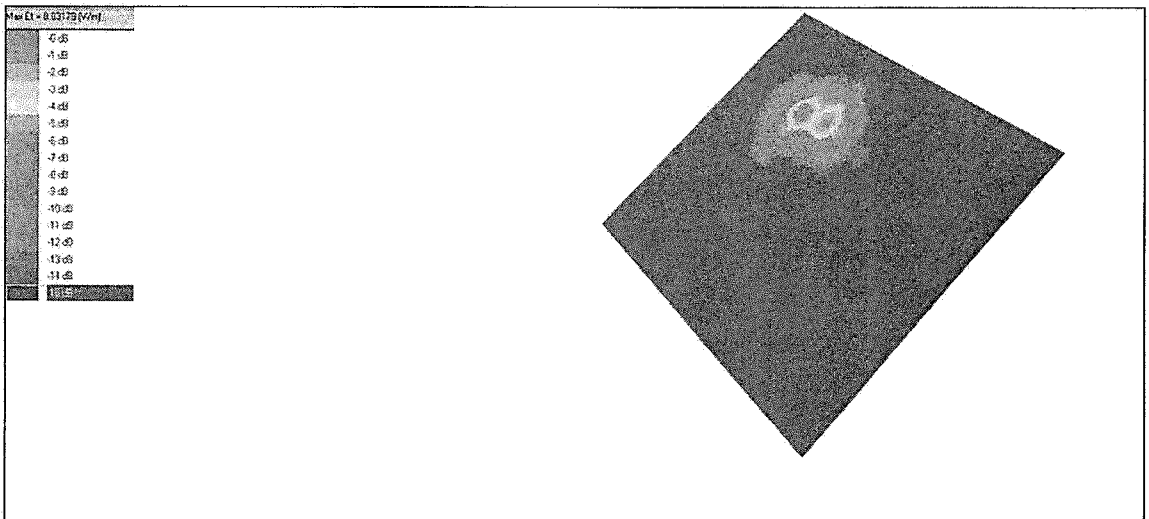

FIG. 16B

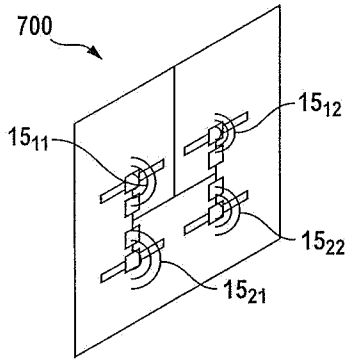

FIG. 17A

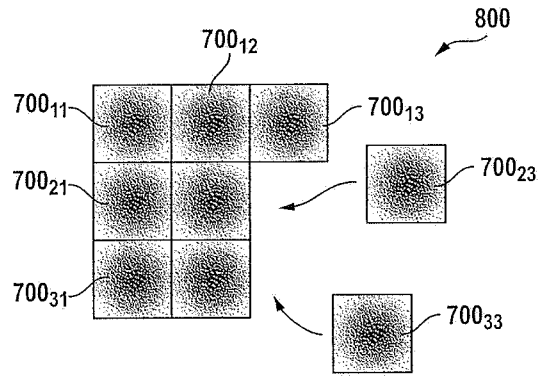

FIG. 17B

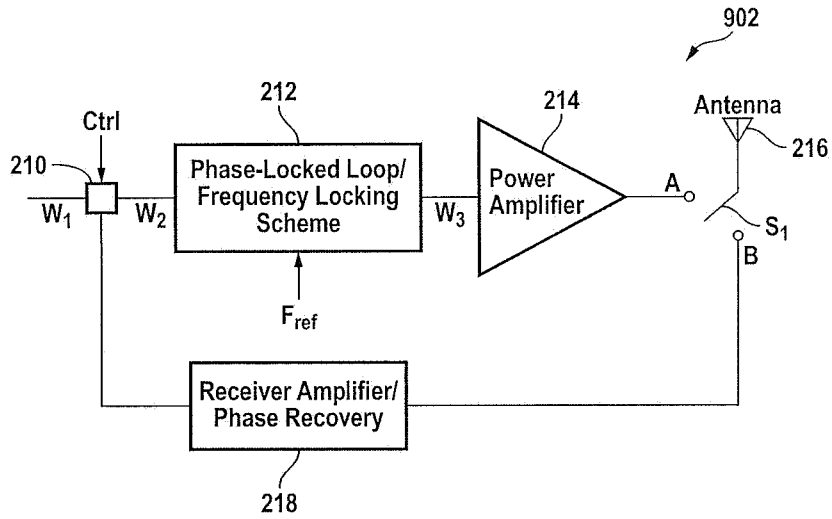

FIG. 18

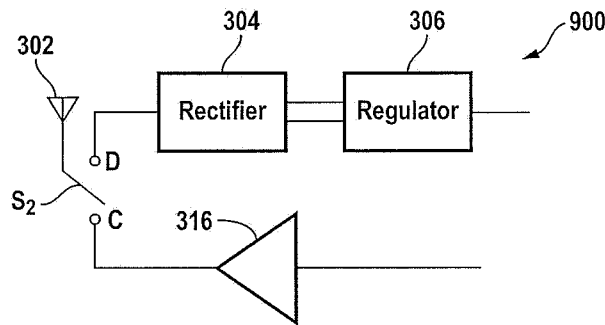

FIG. 19

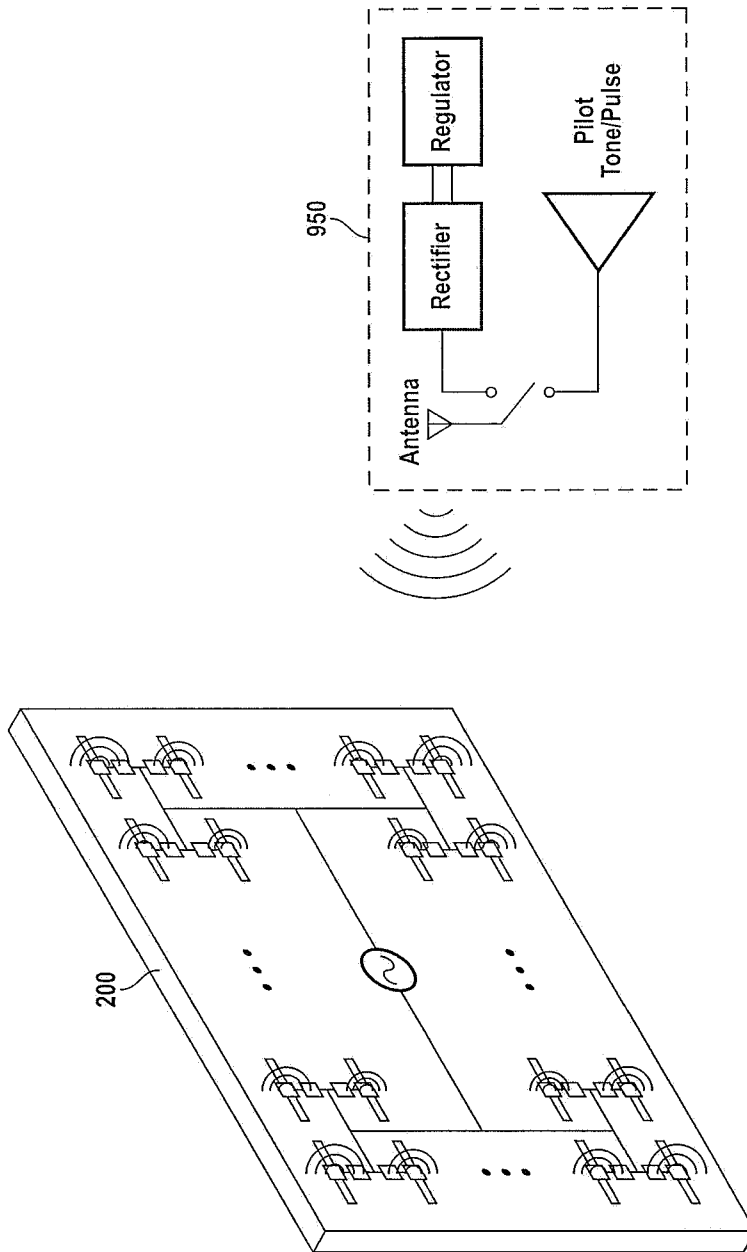

FIG. 20

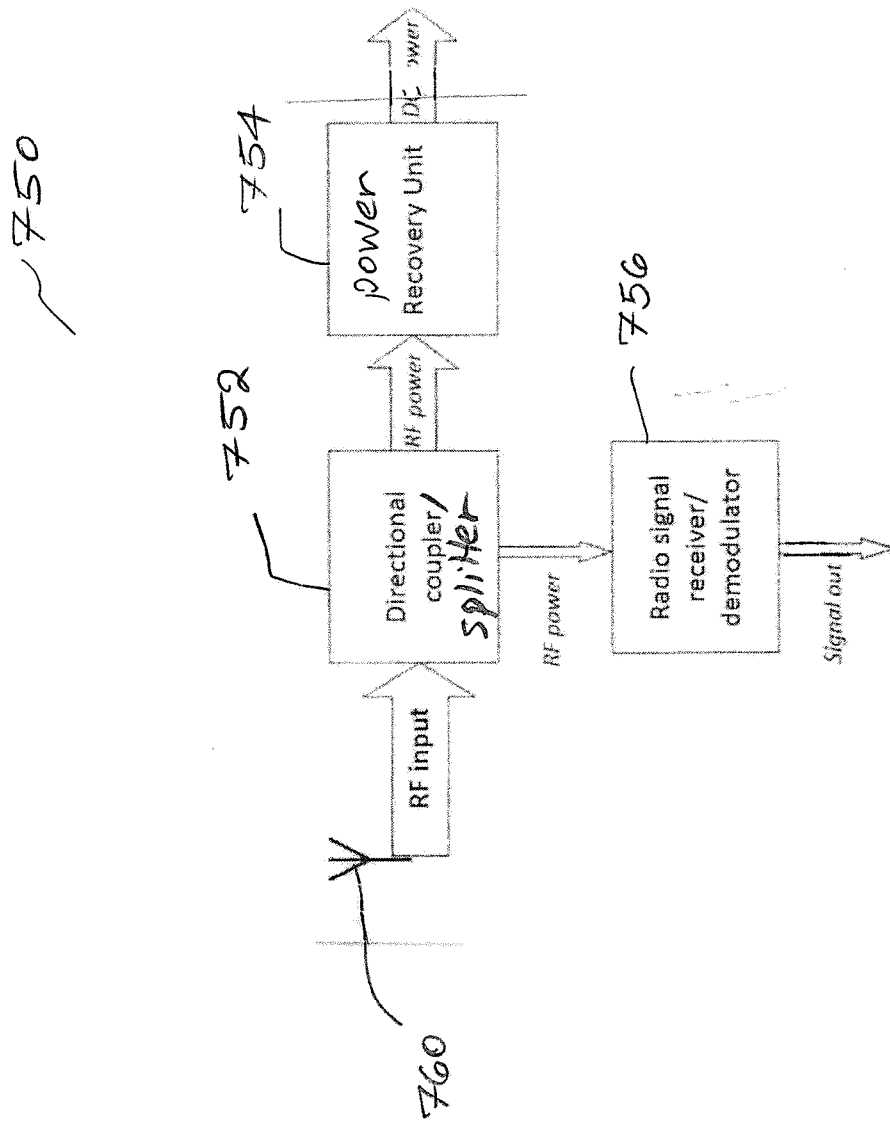

Figure 21A

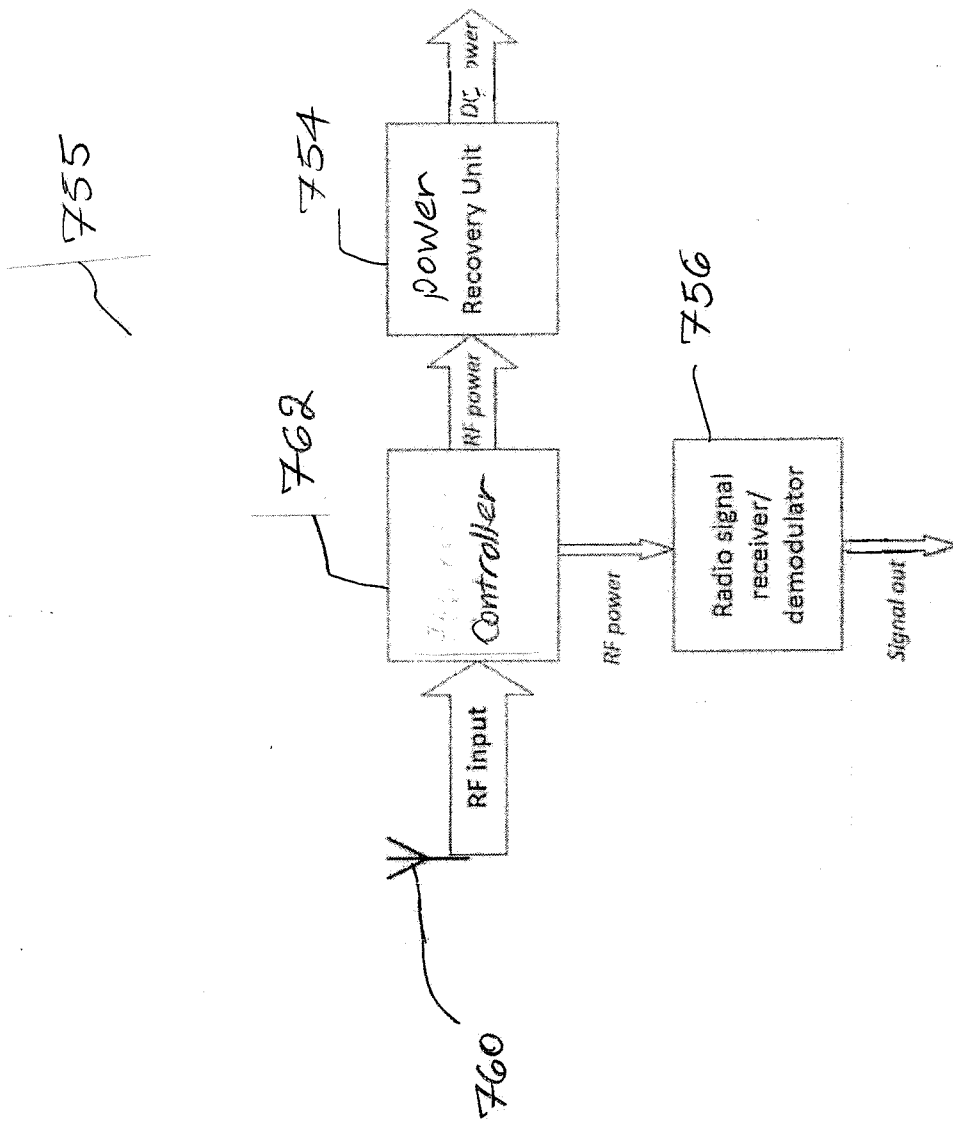

Figure 21B

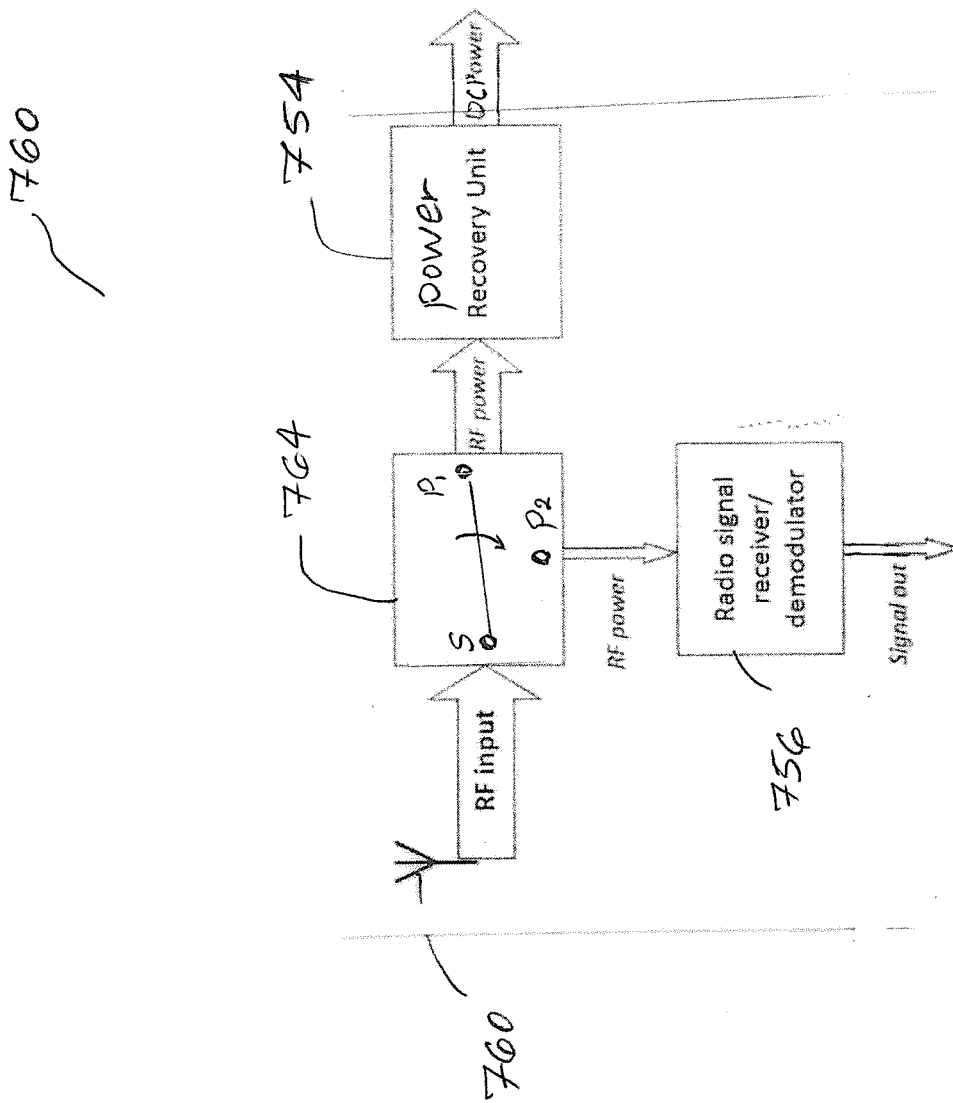

Figure 21C

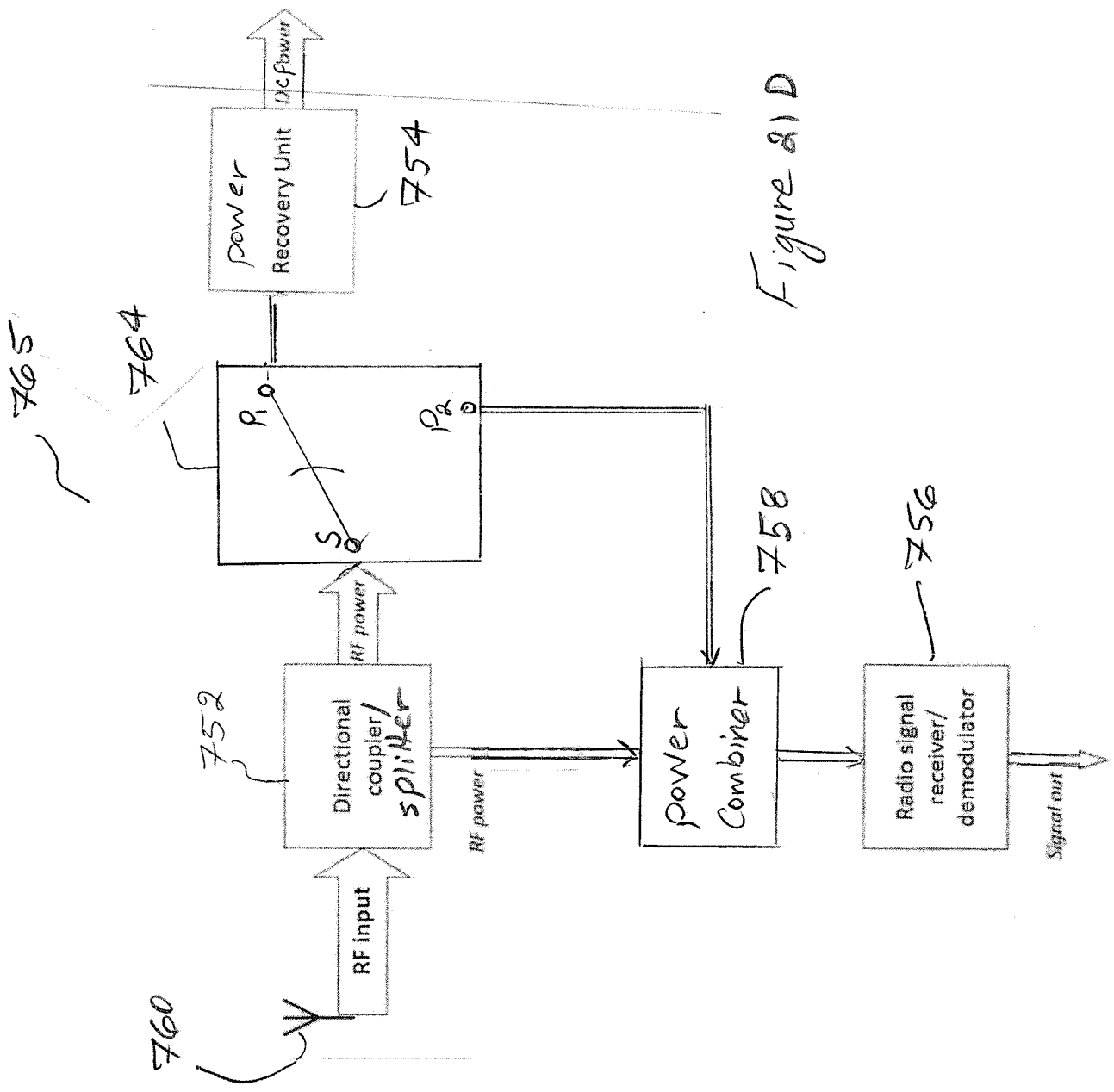
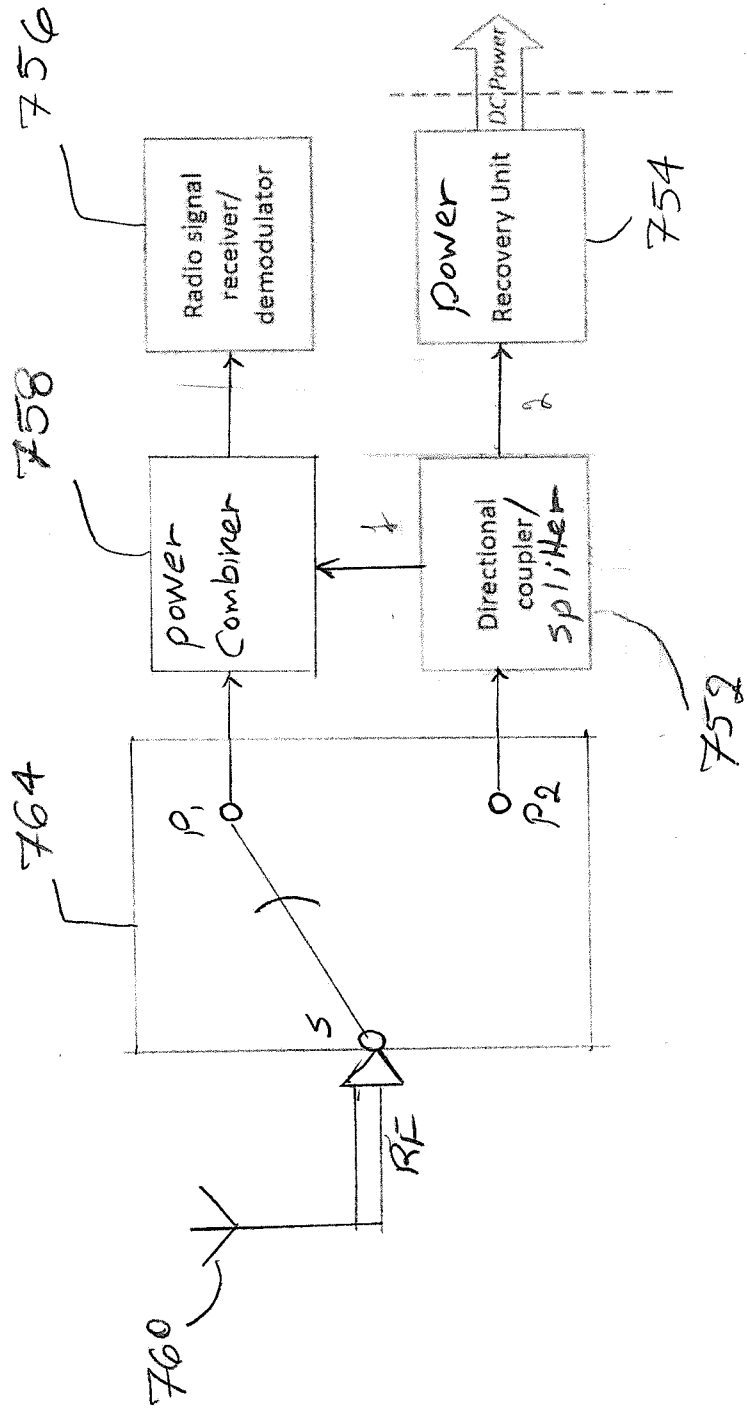
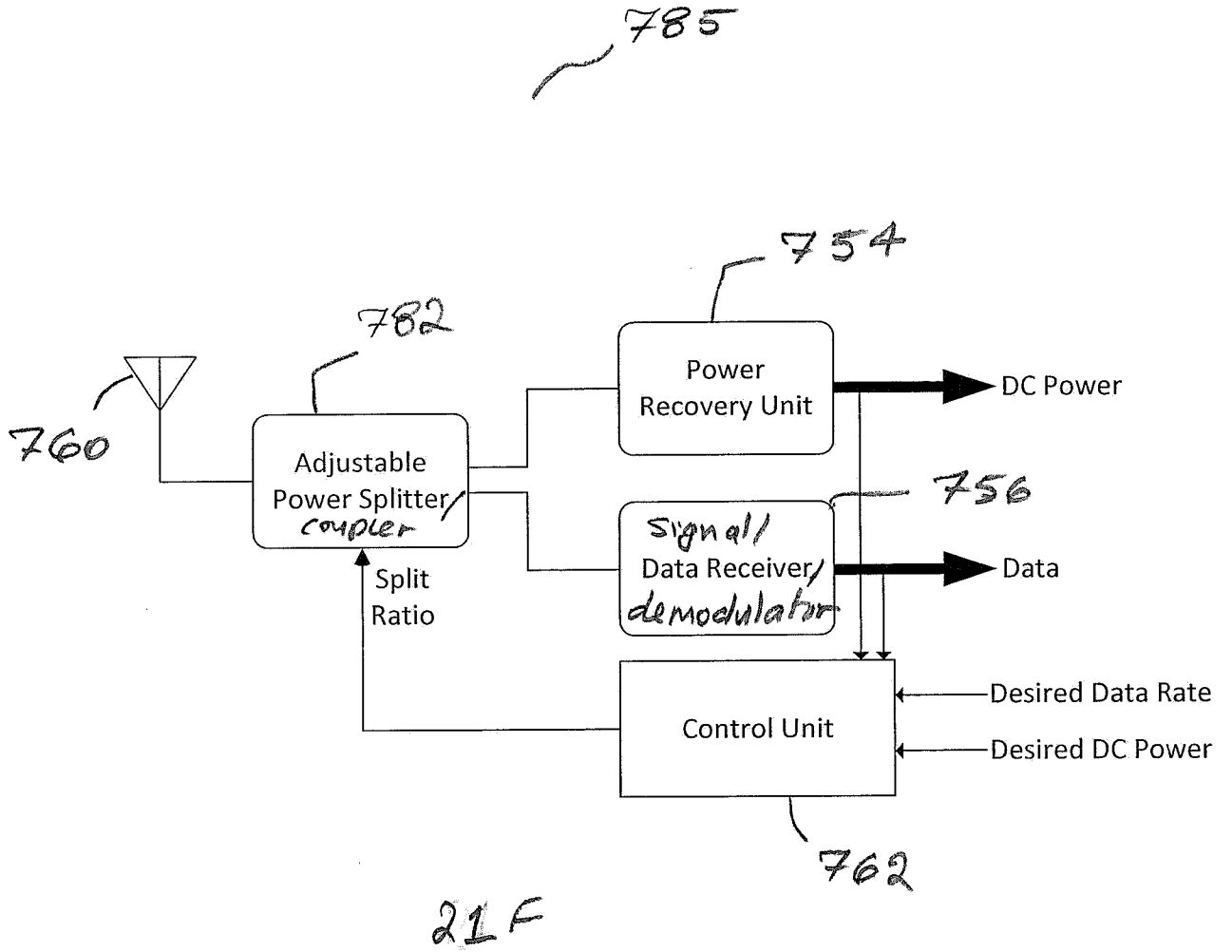

Figure 81D

775



81E



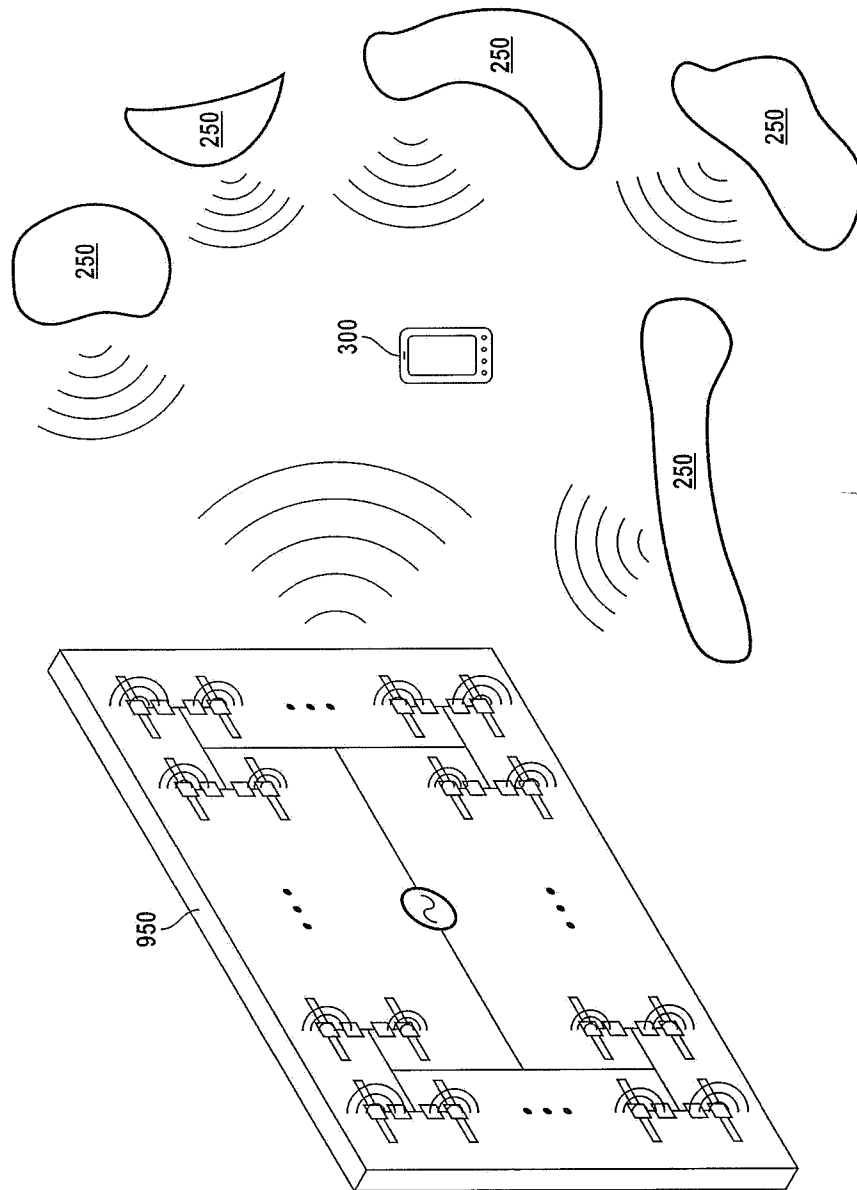

FIG. 22

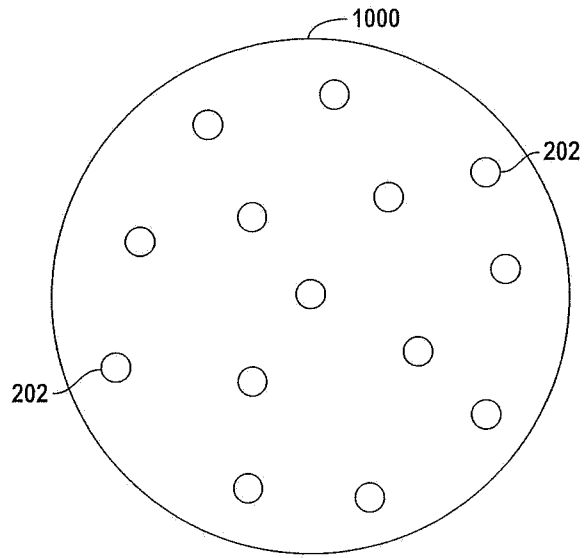

FIG. 23A

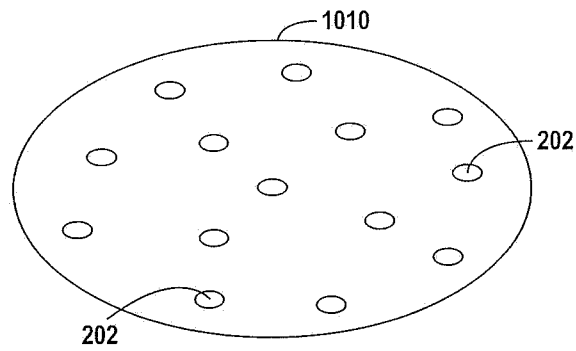

FIG. 23B

INTERNATIONAL SEARCH REPORT

International application No.
PCT/US16/53202

A. CLASSIFICATION OF SUBJECT MATTER
IPC(8) - H04B1/16; H04B1/18; H04B1/06 (2016.01)
CPC - H04B1/1607; H04B1/18; H04B5/0037
According to International Patent Classification (IPC) or to both national classification and IPC

B. FIELDS SEARCHED

Minimum documentation searched (classification system followed by classification symbols)
IPC(8): H04B1/16; H04B1/18; H04B1/06 (2016.01)
CPC: H04B1/1607; H04B1/18; H04B5/0037; H04B1/006

Documentation searched other than minimum documentation to the extent that such documents are included in the fields searched

Electronic data base consulted during the international search (name of data base and, where practicable, search terms used)
PatSeer (US, EP, WO, JP, DE, GB, CN, FR, KR, ES, AU, IN, CA, INPADOC Data); Google Scholar; Ebscohost; IEEE
Keywords: wireless, power, switch, power combiner, converter, antenna, demodulate, data, information, splitter, RF

C. DOCUMENTS CONSIDERED TO BE RELEVANT

Category*	Citation of document, with indication, where appropriate, of the relevant passages	Relevant to claim No.
X -- Y -- A	US 2012/0091799 A1 (ROFOUGARAN, A et al.) 19 April 2012, paragraphs [0142] – [0145], [0173]-[0174], [0205], [0293], [0316], [0321], [0345]	1-2, 10-11, 13, 16, 19, 22 ----- 14-15, 17-18, 20-21 ----- 4-9
X -- Y -- A	EP 2858209 A1 (SAMSUNG ELECTRONICS Co., LTD) 08 April 2015, paragraphs [0001], [0003], [0007], [0011], [0063], [0069], [0073]; fig. 3	3, 12 ----- 15 ----- 4-9
Y	US 2002/0090966 A1 (HANSEN, C et al.) 11 July 2002, paragraphs [0066]-[0067], [0138]	14, 15
Y	US 2011/0167291 A1 (LIU, H et al.) 07 July 2011, paragraph [0021]	17, 20
Y	US 2015/0155739 A1 (BROADCOM CORPORATION) 04 June 2015, paragraphs [0091], [0114]	18, 21
A	US 2010/0208848 A1 (ZHU, L et al.) 19 August 2010, paragraph [0015]	4-9

Further documents are listed in the continuation of Box C. See patent family annex.

* Special categories of cited documents:
 "A" document defining the general state of the art which is not considered to be of particular relevance
 "E" earlier application or patent but published on or after the international filing date
 "L" document which may throw doubts on priority claim(s) or which is cited to establish the publication date of another citation or other special reason (as specified)
 "O" document referring to an oral disclosure, use, exhibition or other means
 "P" document published prior to the international filing date but later than the priority date claimed
 "T" later document published after the international filing date or priority date and not in conflict with the application but cited to understand the principle or theory underlying the invention
 "X" document of particular relevance; the claimed invention cannot be considered novel or cannot be considered to involve an inventive step when the document is taken alone
 "Y" document of particular relevance; the claimed invention cannot be considered to involve an inventive step when the document is combined with one or more other such documents, such combination being obvious to a person skilled in the art
 "&" document member of the same patent family

Date of the actual completion of the international search 07 November 2016 (07.11.2016)	Date of mailing of the international search report 09 DEC 2016
--	--

Name and mailing address of the ISA/US Mail Stop PCT, Attn: ISA/US, Commissioner for Patents P.O. Box 1450, Alexandria, Virginia 22313-1450 Facsimile No. 571-273-8300	Authorized officer Shane Thomas PCT Helpdesk: 571-272-4300 PCT OSP: 571-272-7774
---	--