

(12) INTERNATIONAL APPLICATION PUBLISHED UNDER THE PATENT COOPERATION TREATY (PCT)

(19) World Intellectual Property  
Organization  
International Bureau



(43) International Publication Date  
24 June 2021 (24.06.2021)

(10) International Publication Number  
**WO 2021/126336 A1**

(51) International Patent Classification:

A61B 17/34 (2006.01) A61B 90/11 (2016.01)

(21) International Application Number:

PCT/US2020/052707

(22) International Filing Date:

25 September 2020 (25.09.2020)

(25) Filing Language:

English

(26) Publication Language:

English

(30) Priority Data:

62/950,521 19 December 2019 (19.12.2019) US  
63/076,008 09 September 2020 (09.09.2020) US

(71) Applicant: **CLEARPOINT NEURO, INC.** [US/US]; 5  
Musick, Irvine, California 92618 (US).

(72) Inventors: **DALY, Maxwell, Jerad**; 734 Robinhood Lane,  
Redlands, California 92373 (US). **PIFERI, Peter, G.**; 6026  
E. Teton Avenue, Orange, California 92867 (US).

(74) Agent: **MYERS BIGEL, P.A.**; P.O. Box 37428, Raleigh,  
North Carolina 27627 (US).

(81) Designated States (unless otherwise indicated, for every  
kind of national protection available): AE, AG, AL, AM,  
AO, AT, AU, AZ, BA, BB, BG, BH, BN, BR, BW, BY, BZ,  
CA, CH, CL, CN, CO, CR, CU, CZ, DE, DJ, DK, DM, DO,  
DZ, EC, EE, EG, ES, FI, GB, GD, GE, GH, GM, GT, HN,  
HR, HU, ID, IL, IN, IR, IS, IT, JO, JP, KE, KG, KH, KN,  
KP, KR, KW, KZ, LA, LC, LK, LR, LS, LU, LY, MA, MD,  
ME, MG, MK, MN, MW, MX, MY, MZ, NA, NG, NI, NO,  
NZ, OM, PA, PE, PG, PH, PL, PT, QA, RO, RS, RU, RW,  
SA, SC, SD, SE, SG, SK, SL, ST, SV, SY, TH, TJ, TM, TN,  
TR, TT, TZ, UA, UG, US, UZ, VC, VN, WS, ZA, ZM, ZW.

(84) Designated States (unless otherwise indicated, for every  
kind of regional protection available): ARIPO (BW, GH,  
GM, KE, LR, LS, MW, MZ, NA, RW, SD, SL, ST, SZ, TZ,

UG, ZM, ZW), Eurasian (AM, AZ, BY, KG, KZ, RU, TJ,  
TM), European (AL, AT, BE, BG, CH, CY, CZ, DE, DK,  
EE, ES, FI, FR, GB, GR, HR, HU, IE, IS, IT, LT, LU, LV,  
MC, MK, MT, NL, NO, PL, PT, RO, RS, SE, SI, SK, SM,  
TR), OAPI (BF, BJ, CF, CG, CI, CM, GA, GN, GQ, GW,  
KM, ML, MR, NE, SN, TD, TG).

Published:

— with international search report (Art. 21(3))

(54) Title: FRONT-LOADABLE FLUID TRANSFER ASSEMBLIES AND RELATED MEDICAL FLUID TRANSFER SYSTEMS

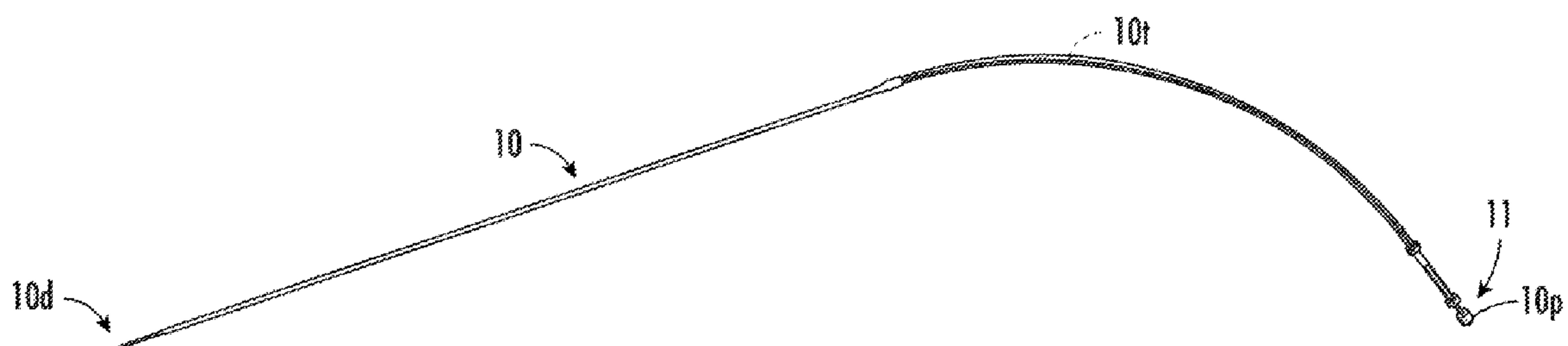

FIG. 1

(57) Abstract: Devices for transferring fluid to or from a subject include a plunger assembly coupled to or coupleable to a cannula assembly to allow target fluid to be "front-loaded" into a distal end of the cannula assembly while the stylet is withdrawn a distance to create a vacuum and define a flow channel.

WO 2021/126336 A1

## FRONT-LOADABLE FLUID TRANSFER ASSEMBLIES AND RELATED MEDICAL FLUID TRANSFER SYSTEMS

### RELATED APPLICATIONS

**[0001]** This application claims the benefit of and priority to U.S. Provisional Patent Application Serial Number 62/950,521 filed December 19, 2019, and U.S. Provisional Patent Application Serial Number 63/076,008 filed September 9, 2020, the contents of which are hereby incorporated by reference as if recited in full herein.

### FIELD OF THE INVENTION

**[0002]** The present invention relates generally to medical devices and systems and, more particularly, to devices and systems for delivering and/or withdrawing substances *in vivo*.

### BACKGROUND

**[0003]** Various therapeutic and diagnostic procedures require that a substance be delivered (e.g., infused) into or aspirated from a prescribed region of a patient, such as to an intrabody target using a delivery device. It may be important or critical that the substance be delivered or removed with accuracy to the target region in the patient and without undue trauma to the patient.

### SUMMARY

**[0004]** It should be appreciated that this Summary is provided to introduce a selection of concepts in a simplified form, the concepts being further described below in the Detailed Description. This Summary is not intended to identify key features or essential features of this disclosure, nor is it intended to limit the scope of the invention.

**[0005]** Embodiments of the invention are directed to front-loadable fluid transfer assemblies for transferring fluid to or from a subject.

**[0006]** Embodiments of the invention are directed to a surgical plunger assembly that includes: a stylet comprising opposing proximal and distal ends; a luer connector comprising an internal seal coupled to the stylet; and a support body coupled to the luer connector and extending above the distal end of the stylet. The support body encloses a sub-length of the stylet and the stylet is longitudinally moveable relative to the support body between first and second positions. In the first position, the proximal end of the stylet is closer to the luer

connector than in the second position.

**[0007]** The plunger assembly can also include a plunger comprising a first segment coupled to or defined by the stylet and a second segment having a greater cross-sectional size than the first segment. The second segment can merge into an external plunger flange. The support body can enclose the first segment and at least a portion of the second segment and the first segment and the second segment can be longitudinally movable relative to the support body. With the plunger in a first position, the stylet is in the first position and the second segment of the stylet resides closer to the luer connector than when the stylet is in the second position.

**[0008]** The plunger assembly can further include a drive screw that resides at least partially in the support body and that is coupled to the proximal end of the stylet.

**[0009]** The plunger assembly can further include a collar that is coupled to the support body and the drive screw. The collar can be rotatable in clockwise and counterclockwise directions to translate the stylet.

**[0010]** The plunger assembly can further include a support tube residing inside the support body and coupled to the luer connector above the seal. The stylet can be slidably coupled to the support tube to retract and extend inside the support tube while the support body slidably retracts and extends in concert with the stylet about an outer wall of the support tube.

**[0011]** Embodiments of the invention are directed to a surgical plunger assembly that includes: a stylet having opposing proximal and distal ends; a luer connector having an internal seal residing adjacent the proximal end of the stylet; a support body coupled to the luer connector and extending above the distal end of the stylet; and a plunger with a first segment coupled to or defined by the stylet and a second segment having a greater cross-sectional size than the first segment. The second segment merges into an external plunger flange. The support body encloses the first segment and at least a portion of the second segment and the first segment and the second segment are longitudinally movable relative to the support body. With the plunger in a first position, the second segment resides closer to the luer connector than in a second position.

**[0012]** The stylet can have a length outside the support body that is in a range of 6 inches and 10 feet in one or both of the first and second positions.

**[0013]** The stylet can have a length outside the support body that is in a range of 6 inches and 10 feet when the plunger is in each of the first and second positions.

- [0014] The stylet can be formed of an MRI compatible material and can have a maximal outer diameter in a range of about 0.005 inches and about 0.020 inches.
- [0015] The stylet can be formed of Nitinol.
- [0016] The stylet can be formed of fused silica.
- [0017] Other embodiments are directed to an intrabody fluid transfer system that includes: a cannula assembly with a proximal end with a luer connector and having a longitudinally opposing distal end with an open channel extending therethrough; and a plunger assembly coupled to the cannula assembly. The plunger assembly can have a stylet that extends in the open channel of the cannula assembly to position a distal end of the stylet adjacent the distal end of the cannula assembly. The open channel and the stylet cooperate to define a fluid channel extending from the distal end of the cannula assembly, optionally having a length in a range of about 1 cm to about 30 cm.
- [0018] With the plunger in a first position associated with a ready to intake fluid or a fully injected position, the distal end of the stylet can extend flush with or out of the distal end of the cannula assembly.
- [0019] Fluid can be held for dispensing to a patient in the fluid channel at a location between the distal end of the cannula assembly and a medial portion of the cannula assembly.
- [0020] The plunger assembly can further include a luer connector with an internal seal residing adjacent the stylet. The luer connector of the plunger assembly can be attached to the luer connector of the cannula assembly. The plunger assembly can also include a support body coupled to the luer connector of the plunger assembly and extending above the distal end of the stylet and a plunger having a first segment coupled to or defined by the stylet and a second segment having a greater cross-sectional size than the first segment. The second segment can merge into an external plunger flange. The support body can enclose the first segment and at least a portion of the second segment and the first segment and the second segment can be longitudinally movable relative to the support body. With the plunger in a first position, the second segment can reside closer to the luer connectors than in a second position.
- [0021] The intrabody fluid transfer assembly can further include a drive screw that resides at least partially in the support body and that is coupled to the proximal end of the stylet.
- [0022] The intrabody fluid transfer assembly can further include a collar that is coupled to the support body and the drive screw. The collar can be rotatable in clockwise and

counterclockwise directions to translate the stylet.

**[0023]** The intrabody fluid transfer assembly can further include a support tube residing inside the support body and coupled to the luer connector above the seal. The stylet can be slidably coupled to the support tube to retract and extend inside the support tube while the support body slidably retracts and extends in concert with the stylet about an outer wall of the support tube.

**[0024]** The stylet can have a length outside the support body that is in a range of 6 inches and 10 feet when the plunger is in each of the first and second positions.

**[0025]** The stylet can be formed of an MRI compatible material and can have a maximal outer diameter in a range of about 0.005 inches and about 0.020 inches.

**[0026]** The stylet can be formed of Nitinol.

**[0027]** The stylet can be formed of fused silica.

**[0028]** Other embodiments are directed to methods for transferring fluid into or from a subject. The methods include: providing a cannula assembly having a luer connector on a proximal end thereof and having a longitudinally opposing distal end; and providing a plunger assembly that is coupleable to or coupled to the cannula assembly. The plunger assembly has a stylet extending from the proximal end to a position proximate, flush with or beyond the distal end of the cannula assembly. The methods further include creating a vacuum by withdrawing the stylet relative to the distal end of the cannula assembly; and intaking target fluid into the distal end of the cannula assembly in response to the vacuum created by the stylet and the cannula assembly.

**[0029]** The methods can also include placing the cannula assembly with the plunger assembly coupled thereto and holding the fluid into a trajectory guide of a surgical navigation system whereby a proximal end portion of the plunger assembly is above the trajectory guide and the distal end of the cannula assembly and stylet are in a body of a patient and transferring the fluid into the patient.

**[0030]** The fluid can include stem cells.

**[0031]** The method can further include delivering the fluid to an intrabrain target site for the transferring step.

**[0032]** It is noted that aspects of the invention described with respect to one embodiment may be incorporated in a different embodiment although not specifically described relative thereto. That is, all embodiments and/or features of any embodiment can be combined in any way and/or combination. Applicant reserves the right to change any

originally filed claim or file any new claim accordingly, including the right to be able to amend any originally filed claim to depend from and/or incorporate any feature of any other claim although not originally claimed in that manner. These and other objects and/or aspects of the present invention are explained in detail below.

#### BRIEF DESCRIPTION OF THE DRAWINGS

[0033] **FIG. 1** is a top perspective view of an example cannula assembly according to embodiments of the present invention.

[0034] **FIG. 2** is a top view of an example plunger assembly according to embodiments of the present invention.

[0035] **FIG. 3** is an assembled view of the plunger and cannula assemblies shown in **FIGs. 1** and **2** forming a fluid transfer assembly according to embodiments of the present invention.

[0036] **FIG. 4** is an enlarged partial view of a proximal end portion of the assembled components shown in **FIG. 3**.

[0037] **FIG. 5A** is a side perspective view of a proximal end portion of the cannula assembly shown in **FIG. 1** and a distal end of the plunger assembly shown in **FIG. 2** in a first assembly configuration.

[0038] **FIG. 5B** shows the proximal end portion of the cannula assembly shown in **FIG. 5A** with the plunger assembly shown in a further assembled state relative to **FIG. 5A**.

[0039] **FIG. 6A** illustrates the luer connector of the cannula assembly of **FIG. 1** attached to the luer connector of the plunger assembly of **FIG. 2** after further insertion from the configuration shown in **FIG. 5B** according to embodiments of the present invention.

[0040] **FIG. 6B** is a greatly enlarged end perspective view of a distal end of the assembled device shown in **FIG. 3**.

[0041] **FIG. 7** is a side perspective view of a proximal end portion of the assembled device shown in **FIG. 3** with the plunger in position for actuation for intaking fluid at the distal end thereof according to embodiments of the present invention.

[0042] **FIG. 8** is a side perspective view of the proximal end portion of the assembled device shown in **FIG. 7** with the plunger in a second position for actuation for dispensing/injecting fluid at the distal end thereof according to embodiments of the present invention.

[0043] **FIG. 9A** is an enlarged distal end perspective view of the assembled device

shown when in the position of **FIG. 7**.

[0044] **FIG. 9B** is an enlarged distal end perspective view of the assembled device shown when in the position of **FIG. 8**.

[0045] **FIG. 10A** is an enlarged partial proximal end perspective view of another example of a plunger assembly according to embodiments of the present invention.

[0046] **FIG. 10B** is a partial section view of an internal interface of support tubing and plunger wire shown in the plunger assembly shown in **FIG. 10A** according to embodiments of the present invention.

[0047] **FIG. 10C** is a partial section view of the plunger assembly shown in **FIG. 10A** according to embodiments of the present invention.

[0048] **FIG. 11** is an enlarged partial perspective view of another embodiment of a plunger assembly according to embodiments of the present invention.

[0049] **FIG. 12** is a greatly enlarged section view of a segment of the proximal end portion of the plunger assembly shown in **FIG. 11**.

[0050] **FIG. 13** is a schematic illustration of a medical intrabody fluid transfer system operable in an image guided surgical navigation system according to embodiments of the present invention.

[0051] **FIG. 14** is an enlarged partial section view of an example cannula and plunger assembly shown in **FIG. 3**, held by a trajectory guide for intrabody placement according to embodiments of the present invention.

[0052] **FIG. 15** is a flow chart of exemplary actions that can be carried out according to embodiments of the present invention.

#### DETAILED DESCRIPTION

[0053] The present invention now is described more fully hereinafter with reference to the accompanying drawings, in which some embodiments of the invention are shown. This invention may, however, be embodied in many different forms and should not be construed as limited to the embodiments set forth herein; rather, these embodiments are provided so that this disclosure will be thorough and complete, and will fully convey the scope of the invention to those skilled in the art.

[0054] Like numbers refer to like elements throughout. In the figures, the thickness of certain lines, layers, components, elements or features may be exaggerated for clarity. The terms "FIG." and "Fig." are used interchangeably with the word "Figure" in the

specification and/or figures.

**[0055]** The terminology used herein is for the purpose of describing particular embodiments only and is not intended to be limiting of the invention. As used herein, the singular forms "a", "an" and "the" are intended to include the plural forms as well, unless the context clearly indicates otherwise. It will be further understood that the terms "comprises" and/or "comprising," when used in this specification, specify the presence of stated features, steps, operations, elements, and/or components, but do not preclude the presence or addition of one or more other features, steps, operations, elements, components, and/or groups thereof. As used herein, the term "and/or" includes any and all combinations of one or more of the associated listed items.

**[0056]** Unless otherwise defined, all terms (including technical and scientific terms) used herein have the same meaning as commonly understood by one of ordinary skill in the art to which this invention belongs. It will be further understood that terms, such as those defined in commonly used dictionaries, should be interpreted as having a meaning that is consistent with their meaning in the context of the specification and relevant art and should not be interpreted in an idealized or overly formal sense unless expressly so defined herein. Well-known functions or constructions may not be described in detail for brevity and/or clarity.

**[0057]** It will be understood that when an element is referred to as being "on", "attached" to, "connected" to, "coupled" with, "contacting", etc., another element, it can be directly on, attached to, connected to, coupled with or contacting the other element or intervening elements may also be present. In contrast, when an element is referred to as being, for example, "directly on", "directly attached" to, "directly connected" to, "directly coupled" with or "directly contacting" another element, there are no intervening elements present. It will also be appreciated by those of skill in the art that references to a structure or feature that is disposed "adjacent" another feature may have portions that overlap or underlie the adjacent feature.

**[0058]** Spatially relative terms, such as "under," "below," "lower," "over," "upper" and the like, may be used herein for ease of description to describe one element or feature's relationship to another element(s) or feature(s) as illustrated in the figures. It will be understood that the spatially relative terms are intended to encompass different orientations of the device in use or operation in addition to the orientation depicted in the figures. For example, if the device in the figures is inverted, elements described as "under" or "beneath"

other elements or features would then be oriented "over" the other elements or features. Thus, the exemplary term "under" can encompass both an orientation of "over" and "under". The device may be otherwise oriented (rotated 90 degrees or at other orientations) and the spatially relative descriptors used herein interpreted accordingly. Similarly, the terms "upwardly," "downwardly," "vertical," "horizontal" and the like are used herein for the purpose of explanation only unless specifically indicated otherwise.

**[0059]** The term "about," as used herein with respect to a value or number, means that the value or number can vary by +/- twenty percent (20%).

**[0060]** The term "monolithic" means that the component (e.g., inner capillary tube or needle) is formed of a single uniform material.

**[0061]** The term "MRI visible" means that a device is visible, directly or indirectly, in an MRI image. The visibility may be indicated by the increased SNR of the MRI signal proximate to the device (the device can act as an MRI receive antenna to collect signal from local tissue) and/or that the device actually generates MRI signal itself, such as via suitable hydro-based coatings and/or fluid (typically aqueous solutions) filled channels or lumens.

**[0062]** The term "MRI compatible" means that a device is safe for use in an MRI environment and/or can operate as intended in an MRI environment without generating MR signal artifacts, and, as such, if residing within the high-field strength region of the magnetic field, is typically made of a non-ferromagnetic MRI compatible material(s) suitable to reside and/or operate in a high magnetic field environment.

**[0063]** The term "high-magnetic field" refers to field strengths above about 0.5T (Tesla), typically above 1.0T, and more typically between about 1.5T and 10T.

**[0064]** The term "near real time" refers to both low latency and high frame rate. Latency is generally measured as the time from when an event occurs to display of the event (total processing time). For tracking, the frame rate can range from between about 100 fps to the imaging frame rate. In some embodiments, the tracking is updated at the imaging frame rate. For near "real-time" imaging, the frame rate is typically between about 1 fps to about 20 fps, and in some embodiments, between about 3 fps to about 7 fps. The low latency required to be considered "near real time" is generally less than or equal to about 1 second. In some embodiments, the latency for tracking information is about 0.01s, and typically between about 0.25-0.5s when interleaved with imaging data. Thus, with respect to tracking, visualizations with the location, orientation and/or configuration of a known intrabody device can be updated with low latency between about 1 fps to about 100 fps. With respect to

imaging, visualizations using near real time MR image data can be presented with a low latency, typically within between about 0.01 ms to less than about 1 second, and with a frame rate that is typically between about 1- 20 fps. Together, the system can use the tracking signal and image signal data to dynamically present anatomy and one or more intrabody devices in the visualization in near real-time. In some embodiments, the tracking signal data is obtained and the associated spatial coordinates are determined while the MR image data is obtained and the resultant visualization(s) with the intrabody device (e.g., stylet) and the near RT MR image(s) are generated.

**[0065]** The term "sterile," as used herein, means that a device, kit, and/or packaging meets or exceeds U.S./Federal Drug Administration and/or other regulatory medical/surgical cleanliness guidelines, and typically is free from live bacteria or other microorganisms.

**[0066]** Embodiments of the present invention can be utilized with various diagnostic or interventional devices and/or therapies to any desired internal region of an object using any suitable imaging modality, typically an MRI and/or in an MRI scanner or MRI interventional suite. However, CT or other imaging modalities may be used. The object can be any object, and may be particularly suitable for animal and/or human subjects for e.g., animal studies and/or veterinarian or human treatments. Some embodiments deliver therapies to the spine. Some embodiments deliver therapies to treat or stimulate a desired region of the sympathetic nerve chain. Other uses, inside or outside the brain, nervous system or spinal cord, include stem cell placement, gene therapy or drug delivery for treating physiological conditions, chemotherapy, drugs including replicating therapy drugs. Some embodiments can be used to treat tumors.

**[0067]** The term "substance," as used herein, refers to a liquid for treating or facilitating diagnosis of a condition and can include bions, stem cells or other target cells to site-specific regions in the body, such as neurological, nerves or other target sites and the like. In some embodiments, stem cells and/or other rebuilding cells or products can be delivered into spine, brain or cardiac tissue, such as a heart wall via a minimally invasive MRI guided procedure, while the heart is beating (i.e., not requiring a non-beating heart with the patient on a heart-lung machine). Examples of known stimulation treatments and/or target body regions are described in U.S. Patent Nos. 6,708,064; 6,438,423; 6,356,786; 6,526,318; 6,405,079; 6,167,311; 6,539,263; 6,609,030 and 6,050,992, the contents of which are hereby incorporated by reference as if recited in full herein.

**[0068]** The term "fluid" with respect to fluid being withdrawn from a subject refers to

soft tissue, foreign matter, biological matter including cellular material and liquid in a subject.

**[0069]** The term "infusion" and derivatives thereof refers to the delivery of a substance (which can be a single substance or a mixture) at a relatively slow rate so that the substance can infuse about a target region. Thus, the term "infusate" refers to a substance so delivered.

**[0070]** The term "semi-rigid" refers to devices that have sufficient rigidity to have a self-supporting fixed shape (typically straight tubular or cylindrical shapes) in the absence of applied bending forces but have sufficient flexibility to be able to bend or deflect without breaking in response to forces applied during insertion into or removal from a trajectory guide (see, for example, **1250t, FIG. 4**), then return to its original self-supporting shape upon removal of the applied force(s).

**[0071]** The term "flexible" means that the device(s) does not have sufficient rigidity to have a fixed shape without support and can be rolled, coiled, folded for example.

**[0072]** The subject can be any subject, and may be particularly suitable for animal and/or human subjects for e.g., animal studies and/or veterinarian or human treatments.

**[0073]** Some embodiments aspirate fluid from a target intrabody region such as, for example, a brain. For example, aspiration of fluid from a target structure can debulk it. Debulking the structure can relieve pressure on the surrounding areas. This can be desirable as it can be performed in a less invasive manner than surgical resection. *See*, U.S. Patent Application Serial No. 16/217,222, the contents of which are hereby incorporated by reference as if recited in full herein.

**[0074]** Embodiments of the invention can deliver therapies to the spine.

**[0075]** Embodiments of the invention can deliver therapies to treat or stimulate a desired region of the sympathetic nerve chain. Other uses, inside or outside the brain, nervous system or spinal cord, include stem cell placement, gene therapy or drug delivery for treating physiological conditions, chemotherapy, drugs including replicating therapy drugs. Some embodiments can be used to treat a patient with one or more tumors.

**[0076]** Embodiments of the present invention will now be described in further detail below with reference to the figures. **FIG. 1** illustrates an exemplary cannula assembly **10**. The cannula assembly **10** is configured for intrabody fluid transfer. **FIG. 2** illustrates an exemplary plunger assembly **100**. **FIG. 3** illustrates the plunger assembly **100** coupled to the cannula assembly **10** to define a transfer assembly **200**. When assembled, the plunger

assembly **100** extends entirely through the cannula assembly **10**. A distal end **100d** of the plunger assembly **100** can reside proximate to, such as inward a distance of about 1 mm relative to the distal end **10d**, flush with and/or extend out beyond the distal end **10d** of the cannula assembly **10** and a proximal end **100p** of the plunger assembly **100** extends beyond a proximal end **10p** of the cannula assembly **10**. The distal end **100d** of the plunger assembly **100** can be configured to extend a short distance, such as less than 1 mm, typically such as a distance in a range of about 0-0.5 mm, beyond the distal end **10d** of the cannula assembly in a ready to load and/or fully dispensed position. The proximal end **10p** of the cannula assembly **10** can comprise a luer connector **11**.

[0077] In some embodiments, the plunger assembly **100** is configured to cooperate with the cannula assembly **10**, allowing the assembled device **200** to be “front loaded”. The purpose of front loading the cannula assembly **10** is to load a target fluid into a delivery device to minimize and/or not create any “dead space”. The term “dead space” refers to a situation where an undesirable amount of drug is left in a syringe or lumen of the cannula, after a delivery such as an infusion is complete. This can be particularly undesirable where a target drug for delivery is in limited supply such as comprising stem cells and/or where a cell sample obtained from a patient is very small.

[0078] Referring to **FIGs. 2-4**, as shown, the plunger assembly **100** includes a support body **106** that can optionally be cylindrical (or other shape such as a polygonal or triangular shape) and comprises a luer hub **105** on a distal end thereof. The plunger assembly **100** can also include a plunger support flange **108** on an opposing proximal end.

[0079] The plunger assembly **100** can also include a plunger flange **110** that defines the proximal end **100p** of the plunger assembly **100**.

[0080] As is also shown, the plunger assembly **100** comprises a long stylet **101**. The long stylet **101** is elongate and has a length **L** (in a longitudinal direction) that is greater than a length of the support body **106**. Typically, the plunger cannula assembly **100** extends an overall length **L** that can be greater than an overall length **L** of the cannula assembly **10**, such as in a range of about 1 foot to about 10 feet including about 1.5 feet, about 2 feet, about 2.5 feet, about 3 feet, about 3.5 feet, about 4 feet, about 4.5 feet, about 5 feet, about 5.5 feet, about 6 feet, about 6.5 feet, about 7 feet, about 7.5 feet, about 8 feet, about 8.5 feet, about 9 feet, about 9.5 feet and about 10 feet. If sufficiently long, the plunger assembly **100** can be actuated from outside a bore **1350b** of a magnet **1350** of an MRI Scanner **1220** (**FIG. 13**) allowing efficient delivery during an image-guided surgical procedure.

[0081] The stylet **101** can be configured to fit any target inner diameter of a respective cannula assembly **10**. The plunger assembly **100** can have sufficient flexibility to be able to change in shape from a linear configuration to a curved configuration as shown with respect to **FIG. 2** and **FIG. 3**.

[0082] The cannula assembly **10** may have an inner diameter in a range of about 0.008 inches to about 0.021 inches, which may be particularly suitable for certain infusion uses.

[0083] When an operator pulls back on the plunger **102**, the stylet **101** travels back as well creating a vacuum that evacuates/sucks a fluid such as a drug from a distal end **10d** of cannula assembly **10** into the cannula assembly **10** about the stylet **101**. Typically, the “front-loaded” drug resides upstream of the distal end **10d** of the cannula assembly **10** a distance corresponding to a stroke distance of the plunger **102** and/or a distance in a range of 1 cm to about 30 cm or a range of about 5 cm to about 15 cm. The distance can be, for example, about 1 cm, about 2 cm, about 3 cm, about 4 cm, about 5 cm, about 6 cm, about 7 cm, about 8 cm, about 9 cm, about 10 cm, about 11 cm, about 12 cm, about 13 cm, about 14 cm, about 15 cm, about 16 cm, about 17 cm, about 18 cm, about 19 cm, about 20 cm, about 21 cm, about 22 cm, about 23 cm, about 24 cm, about 25 cm, about 26 cm, about 27 cm, about 28 cm, about 29 cm and about 30 cm. The stroke travel distance is below the luer connector **11** and/or luer hub **105** and/or support body **106**, more typically between the distal end **10d** of the cannula assembly **10** and a medial location **10m** of the cannula assembly **10**.

[0084] When the plunger **102** is moved forward toward the distal end **10d** of the cannula assembly **10**, the stylet **101** pushes the fluid, e.g., drug, out of the cannula assembly **10** into a target location such as the brain or heart, for example.

[0085] Referring to **FIGs. 5A, 5B, 6A** and **6B**, the plunger assembly **100** can attach to the cannula assembly **10** by inserting the stylet **101** into the proximal end **10p** of the cannula assembly **10** and threading/pushing the stylet **101** forward to the distal end **10d** of the cannula assembly **10**, then the plunger assembly **100** can be coupled to (typically locked onto) the cannula assembly **10** at the luer connector **11** (**FIG. 6A**), similar to a syringe. When fully seated, the distal end **100d** of the plunger assembly **100** can reside at a distal end **10d** of the cannula assembly **10**, and can protrude a distance in a range of about 0-0.5 mm (**FIG. 6B**) in some particular embodiments.

[0086] **FIG. 7** illustrates the plunger/cannula assembly **200** in a ready to intake configuration with the plunger flange **110** adjacent the support body flange **108** and the first

segment **102a** of the plunger **102** having a shorter length inside the support body **106** than the position shown in **FIG. 8**, with the second segment **102b** residing closer to the seal **103** and luer hub **105** in the ready to intake configuration: **FIGs. 7, 9A** versus the retracted and loaded position shown in **FIGs. 8; 9B** (the latter having the stylet **101** retracted from the distal end **10d** of the cannula assembly).

[0087] When in the configuration shown in **FIG. 8**, the assembly **200** can be inserted through a stereotactic guidance system such as a trajectory guide **1250t** (**FIG. 14**) with the plunger flange **110** accessible to move up and down relative to a patient and the fluid **F** delivered to or obtained from a patient using the assembly **200**.

[0088] The plunger assembly **100** can be provided in a kit assembled to the cannula assembly **10**.

[0089] The plunger assembly **100** can be provided as a separate component in a package with or in a different package from the cannula assembly **10**.

[0090] The drug can be provided separate from the plunger assembly **10** and/or cannula assembly **100** and is typically loaded onsite prior to delivery.

[0091] In some embodiments, for MRI conditional use (safe for use about an MRI Scanner room with magnets generating a magnetic field, but cannot be inserted during active MRI scanning), the stylet **101** can comprise Nitinol wire. In some embodiments, for MRI-safe use (safe for use in an MRI Scanner room even during scanning), the stylet **101** can comprise fused silica.

[0092] In some embodiments, for CT or other imaging modalities other materials may be used, preferably biocompatible and inert with respect to the target drug or fluid.

[0093] The stylet **101** defines or is attached to a plunger **102**. The plunger **102** and stylet **101** are longitudinally extendable and retractable (as a unit/in concert) relative to the cannula assembly **10** and/or a luer hub **105** attached to the plunger assembly **100**.

[0094] An internal seal **103** can reside at the luer hub **105**. The internal seal **103** can define a fluid-tight seal about a segment of the stylet **101** defining a segment of the plunger **102w**. The segment of the plunger defined by the stylet **101** can be a small diameter wire **102w**.

[0095] In some embodiments, at least an elongate segment of the stylet **101** that resides in a distal and medial (intrabody) portion of the cannula assembly **10** can be solid (have a solid core) and have an outer diameter in a range of about 0.005 inches and about 0.020 inches.

[0096] The plunger **102** can comprise a first segment **102a** that merges into a longitudinally extending second segment **102b**. The second segment **102b** can have a greater cross-sectional size relative to the first segment **102a** inside a support body **106**. The second segment **102b** can snugly slidably engage the support body **106** but is not required to be fluidly sealed thereto. The support body **106** can be configured to support the plunger **102** including at least part of segments **102a**, **102b** during actuation to inhibit buckling.

[0097] At least a portion of the first segment **102a** and a portion of the second segment **102b** can reside in the support body **106** when in a fully extended position with the distal end **100d** outside the distal end **10d** of the cannula assembly (**FIGs. 7, 9A**) and when in a retracted position for loading/intaking fluid (**FIGs. 8, 9B**). Thus, the second segment **102b** can travel longitudinally with respect to the support body **106** but does not travel below the internal seal **103** and/or luer hub **105** (**FIG. 7**). The stroke distance “**d**”, between the maximal extended and retracted operative positions, e.g., a location to intake/load fluid relative to a fully assembled position (**FIG. 7**), can be a distance in a range of about 1 cm to about 30 cm or a range of about 5 cm to about 15 cm, depending on a desired amount of fluid to be loaded into the flow channel **10f** of the assembled device **200** (**FIGs. 3, 7, 8**). The flow channel **10f** may have an annular segment defined by the stylet and cannula assembly. The stroke distance can be, for example, about 1 cm, about 2 cm, about 3 cm, about 4 cm, about 5 cm, about 6 cm, about 7 cm, about 8 cm, about 9 cm, about 10 cm, about 11 cm, about 12 cm, about 13 cm, about 14 cm, about 15 cm, about 16 cm, about 17 cm, about 18 cm, about 19 cm, about 20 cm, about 21 cm, about 22 cm, about 23 cm, about 24 cm, about 25 cm, about 26 cm, about 27 cm, about 28 cm, about 29 cm and about 30 cm.

[0098] The distal end of the stylet **101** can travel 1:1 with the plunger **102** proximal end and pull fluid in to the cannula **10** in a 1:1 ratio, e.g., 1 cm of plunger travel can intake fluid a distance of 1 cm.

[0099] The stylet **101** and the cannula assembly **10** can be sized and configured to create a vacuum and intake the fluid using the vacuum to front load the cannula assembly **10**. The differential between the inner diameter of the cannula **10** and the outer diameter of the stylet **101** to create a desirable vacuum can be in arrange of about 0.0005 inches and 0.10 inches, for example.

[00100] The cannula assembly **10** can comprise an inner tube **10t** of continuous length and may have a constant inner diameter, at least over a major portion of a length thereof. In

some embodiments, the inner tube can be one continuous piece of material, typically of either PEEK or fused silica glass that extends from the distal end **10d** to the connector **11**.

[00101] Referring to **FIG. 1**, the stylet **101** can cooperate with the inner tube **10t** and define a flow channel **10f** (**FIG. 9A**). The flow channel **10f** can have an outer diameter that can be in a range about 0.005 inches and about 0.020 inches, in a range of 100  $\mu\text{m}$  to about 750  $\mu\text{m}$ , such as about 200  $\mu\text{m}$ , or in a range of about 0.20 mm to about .05 mm, such as about 0.20 mm or about 0.053 mm.

[00102] The inner tube **10t** can comprise fused silica glass or PEEK or other material. The stylet **101** and inner tube **10t** can be substantially, if not totally, inert and sterile, so as not to chemically interact with any target fluid in the flow lumen **10f** (**FIG. 9A**).

[00103] Referring to **FIGs. 1, 6B, 9B**, the cannula assembly **10** can comprise an outer tube **12** that can be closely spaced to the inner surface of the outer wall of the inner tube **10t** to inhibit reverse flow and/or provide a fluid-resistant interface to inhibit flow therebetween.

[00104] Referring to **FIG. 10A**, the plunger assembly **100** can comprise graduated indicia of depth/distance on the support body **106**. The support flange **108** can also include a flange **108** that has an outer perimeter **108p** with long sides **108l** connected by shorter sides **108s**. The shorter sides **108s** can define finger gripping surfaces. A lock member **118** such as a thumbscrew can be provided on at least one of the long sides **108**. The shorter sides **108s** can be arcuate while the longer sides may be planar. The shorter sides **108s** can comprise ridges **108r**. The lock member **118** can be configured to directly couple to an outer surface **102s** of the second segment **102b** of the plunger **102** inside the support body **106**. **FIGs. 10B** and **10C** illustrate that the second segment **102b** of the plunger **102** can comprise a sleeve **102s** with a longitudinally extending channel **102c**. The channel **102c** can extend above a proximal end portion **101p** of the stylet **101**. The proximal end portion **101p** of the stylet **101** can be affixed to the channel **102c** so that the sleeve **102s** (plunger wire outer body) and stylet **101** slide in concert.

[00105] **FIGs 10B** and **10c** illustrate that the plunger assembly **100** can further include a support tube **1101** that resides between the seal **103** of the luer hub **105** and the plunger flange **110** and encases a portion of the stylet **101**. The support tube **1101** can have a distal end portion **1101d** that resides in an inwardly extending neck **105** of the luer hub **105**, axially aligned with the channel **102c** of the sleeve **102**.

[00106] As shown in **FIG. 10C**, a proximal end portion **1101p** of the support tube **1101** can terminate proximate an outer end of the support flange **108**. The support tube **1101**

can reside inside the sleeve **102s** and can terminate short of the proximal end portion **101p** of the stylet **101**. The proximal end portion **101p** of the stylet **101** can be affixed to the plunger flange **110** via a bond **1112** inside the channel **102c** under the flange **110**.

[00107] The stylet **101** can be configured to slide longitudinally inside the support tube **1101** and the sleeve **102** can slide longitudinally outside the support tube **1101**. The support tube **1101** can have a stationary configuration inside the support body **106**. At least one end portion of the support tube **1101** can be affixed, such as via a bond **1113**, to the support tube **106**, shown as indirectly attached to the support tube **106**, to anchor the support tube **1101** in a fixed position in the plunger assembly **100**.

[00108] Turning now to **FIGs. 11** and **12**, another embodiment of a plunger assembly **100'** is shown. In this embodiment, a drive screw **220** can be used to translate the stylet **101** instead of a plunger **102**, which may provide for increased precision over manual plunger operation using the plunger flange. The stylet **101** can be attached to the drive screw **220** inside the support body **106**, above the luer hub **105** with the seal **103**. The plunger assembly **100'** can include a collar **210** that is affixed to the screw **220**. Rotation of the collar **210** can translate the drive screw **220**, which retracts or extends the stylet **101**.

[00109] One full rotation of the collar **210** can translate the stylet **101** a defined distance, such as a distance in a range of about 0.1 mm and about 2 mm. In some embodiments, one rotation of the collar **210** can be configured to provide about 1 mm of longitudinal travel (retraction and extension) of the stylet **101**.

[00110] The stylet **101** can be affixed to the drive screw **220**. The proximal end portion **101p** of the stylet can extend into a channel in the screw **220**. The proximal end portion **101p** of the stylet **101** can be bonded to the screw **220**.

[00111] The collar **210** can be fixed to the support body **106**. A set screw **240** can thread into the support body **106**. The set screw **240** can prevent the drive screw **220** from rotating inside the collar **210**.

[00112] A dowel pin **230** can engage an interior groove **230g** in the collar **210** to keep the collar **210** assembled to the support body **106** and/or prevent the drive screw **220** from rotating. The collar **210** can have internal threads **212** that engage the threads **221** of the drive screw **220**.

[00113] A proximal end portion **220p** of the drive screw **220** can extend out of the collar **210**. The threads **212** can extend over a sub-length of the collar **210** inside the collar **210**.

[00114] Although not shown, the support tube **1101** discussed above, can be provided in the support body **106**, under the drive screw **220**.

[00115] Referring to **FIG. 14**, the assembly **200** can extend through a tubular support **260** of a trajectory guide **1250t** that can be held by a base or frame e.g., a stereotactic frame that can be secured to the patient or that can be secured to a holder residing over the patient. A lock **170** can be used to secure the assembly **200** at a desired position in the tubular support **260** to place the distal end **10d** at a target region **A** and withdraw or delivery substance **F**. See, e.g., U.S. Patent Nos. 8,315,689, 8,175,677 and 8,374,677 and US Patent Application Publication No. 2010/0198052 (Serial No. 12/694,865) for descriptions of patient planning and entry protocols and frames and trajectory guides, the contents of which are hereby incorporated by reference as if recited in full herein.

[00116] **FIG. 13** illustrates an MRI-guided interventional system **500** with an MRI scanner **1220**, a clinician workstation **1230** with at least one circuit **1230c**, at least one display **1232**, an MRI compatible trajectory guide **1250t** and a fluid transfer assembly **200**. The system **500** can be configured to render or generate near real time or real time visualizations of the target anatomical space using MRI image data and predefined data of at least one surgical tool (e.g., tubular cannula **20** and/or trajectory guide **1250t**) to segment the image data and place the trajectory guide **1250t** and the cannula **20** in the rendered visualization in the correct orientation and position in 3D space (which is the MRI surgical space for MRI embodiments), anatomically registered to a patient. The trajectory guide **1250t** and the cannula **20** can include or cooperate with tracking, monitoring and/or other interventional components.

[00117] The trajectory guide **1250t** can be configured to provide one or more of an X-Y adjustment and/or pitch and roll adjustment in order to accurately position the assembly **200** at a desired location within a patient. For additional discussion of examples of suitable trajectory guides, see U.S. Patent No. 8,374,677, the contents of which are hereby incorporated by reference as if recited in full herein. However, it is noted that other trajectory guide configurations may be used and embodiments of the invention are not limited by the examples of the trajectory guides herein.

[00118] According to some embodiments, the systems are configured to provide a substantially automated or semi-automated and relatively easy-to-use MRI-guided system with defined workflow steps and interactive visualizations. In particular embodiments, the systems define and present workflow with discrete steps for finding target and entry point(s),

guiding the alignment of the targeting cannula to a planned trajectory, monitoring the insertion of the cannula assembly **200**, and adjusting the (X-Y) position in cases where the placement needs to be corrected. During steps where specific MR scans are used, the circuit or computer module can display data for scan plane center and angulation to be entered at the console. The workstation/circuit can passively or actively communicate with the MR scanner. The system can also be configured to use functional patient data (e.g., fiber tracks, fMRI and the like) to help plan or refine a target surgical site and/or access path.

[00119] The system **500** may also include a decoupling/tuning circuit that allows the system to cooperate with the MRI scanner **1220** and filters and the like. *See, e.g.*, U.S. Patent Nos. 6,701,176; 6,904,307 and U.S. Patent Application Publication No. 2003/0050557, the contents of which are hereby incorporated by reference as if recited in full herein.

[00120] The assembly **200** can be configured to flowably introduce, infuse and/or inject a desired therapy substance (e.g., antigen, gene therapy, chemotherapy or stem-cell or other therapy type).

[00121] In some embodiments, the intrabody fluid transfer assembly **200** is configured to deliver a drug therapy to the brain. The drug therapy can comprise substance **F** delivered to the target site or region **A** (**FIG. 14**) through the fluid/flow channel **10f** (**FIG. 6B**) and may be any suitable and desired substance for drug discovery, animal or human clinical trials and/or approved medical procedures. According to some embodiments, the substance **F** is a liquid or slurry. In the case of a tumor, the substance may be a chemotherapeutic (cytotoxic) fluid. In some embodiments, the substance can include certain types of advantageous cells that act as vaccines or other medicaments (for example, antigen presenting cells such as dendritic cells). The dendritic cells may be pulsed with one or more antigens and/or with RNA encoding one or more antigen. Exemplary antigens are tumor-specific or pathogen-specific antigens. Examples of tumor-specific antigens include, but are not limited to, antigens from tumors such as renal cell tumors, melanoma, leukemia, myeloma, breast cancer, prostate cancer, ovarian cancer, lung cancer and bladder cancer. Examples of pathogen-specific antigens include, but are not limited to, antigens specific for HIV or HCV. In some embodiments, the substance **F** may comprise radioactive material such as radioactive seeds. Substances **F** delivered to a target area in accordance with embodiments of the present invention may include, but are not limited to, the following drugs (including any combinations thereof) listed in **Table 1**:

**Table 1**

| <b>DRUG (generic name)</b>  | <b>DISORDER(S)</b>  |
|-----------------------------|---|
| Caprylidene                 | Alzheimer's disease   |
| Donepezil                   | Alzheimer's disease   |
| Galantamine                 | Alzheimer's disease   |
| Memantine                   | Alzheimer's disease   |
| Tacrine                     | Alzheimer's disease   |
| vitamin E                   | Alzheimer's disease   |
| ergoloid mesylates          | Alzheimer's disease   |
| Riluzole                    | Amyotrophic lateral sclerosis                                   |
| Metoprolol                  | Benign essential tremors  |
| Primidone                   | Benign essential tremors  |
| Propranolol                 | Benign essential tremors  |
| Gabapentin                  | Benign essential tremors & Epilepsy                             |
| Nadolol                     | Benign essential tremors & Parkinson's disease                  |
| Zonisamide                  | Benign essential tremors & Parkinson's disease                  |
| Carmustine                  | Brain tumor   |
| Lomustine                   | Brain tumor   |
| Methotrexate                | Brain tumor   |
| Cisplatin                   | Brain tumor & Neuroblastoma                                     |
| Ioversol                    | Cerebral arteriography  |
| Mannitol                    | Cerebral Edema  |
| Dexamethasone               | Cerebral Edema & Neurosarcoidosis                               |
| Baclofen                    | Cerebral spasticity   |
| Ticlopidine                 | Cerebral thrombosis / embolism                                  |
| Isoxsuprine                 | Cerebrovascular insufficiency                                   |
| Cefotaxime                  | CNS infection & Meningitis                                      |
| Acyclovir                   | Encephalitis  |
| Foscarnet                   | Encephalitis  |
| Ganciclovir                 | Encephalitis  |
| interferon alpha-2a         | Encephalitis  |
| Carbamazepine               | Epilepsy  |
| Clonazepam                  | Epilepsy  |
| Diazepam                    | Epilepsy  |
| divalproex sodium           | Epilepsy  |
| Ethosuximide                | Epilepsy  |
| Ethotoin                    | Epilepsy  |
| Felbamate                   | Epilepsy  |
| Fosphenytoin                | Epilepsy  |
| Levetiracetam               | Epilepsy  |
| Mephobarbital               | Epilepsy  |
| Paramethadione              | Epilepsy  |
| Phenytoin                   | Epilepsy  |
| Trimethadione               | Epilepsy  |
| Pregabalin                  | Epilepsy & Neuralgia  |
| immune globulin intravenous | Guillain-Barre Syndrome   |
| interferon beta-1b          | Guillain-Barre Syndrome & Multiple sclerosis                    |
| Azathioprine                | Guillain-Barre Syndrome & Multiple sclerosis & Neurosarcoidosis |

| DRUG (generic name)           | DISORDER(S)                                      |
|-------------------------------|--|
| Risperidone                   | Head injury                                      |
| Tetrabenazine                 | Huntington's disease                             |
| Acetazolamide                 | Hydrocephalus & Epilepsy                         |
| Alteplase                     | Ischemic stroke                                  |
| Clopidogrel                   | Ischemic stroke                                  |
| Nimodipine                    | Ischemic stroke & Subarachnoid hemorrhage        |
| Aspirin                       | Ischemic stroke & Thromboembolic stroke          |
| Amikacin                      | Encaphalitis                                     |
| Ampicillin                    | Encaphalitis                                     |
| ampicillin/sulbactam          | Encaphalitis                                     |
| Ceftazidime                   | Encaphalitis                                     |
| Ceftizoxime                   | Encaphalitis                                     |
| Cefuroxime                    | Encaphalitis                                     |
| Chloramphenicol               | Encaphalitis                                     |
| cilastatin/imipenem           | Encaphalitis                                     |
| Gentamicin                    | Encaphalitis                                     |
| Meropenem                     | Encaphalitis                                     |
| Metronidazole                 | Encaphalitis                                     |
| Nafcillin                     | Encaphalitis                                     |
| Oxacillin                     | Encaphalitis                                     |
| Piperacillin                  | Encaphalitis                                     |
| Rifampin                      | Encaphalitis                                     |
| sulfamethoxazole/trimethoprim | Encaphalitis                                     |
| Tobramycin                    | Encaphalitis                                     |
| Triamcinolone                 | Encaphalitis                                     |
| Vancomycin                    | Encaphalitis                                     |
| Ceftriaxone                   | Encaphalitis & Neurosyphilis                     |
| Penicillin                    | Encaphalitis & Neurosyphilis                     |
| Corticotrophin                | Multiple sclerosis                               |
| Dalfampridine                 | Multiple sclerosis                               |
| Glatiramer                    | Multiple sclerosis                               |
| Mitoxantrone                  | Multiple sclerosis                               |
| Natalizumab                   | Multiple sclerosis                               |
| Modafinil                     | Multiple sclerosis                               |
| Cyclophosphamide              | Multiple sclerosis & Brain tumor & Neuroblastoma |
| interferon beta-1a            | Multiple sclerosis & Neuritis                    |
| Prednisolone                  | Multiple sclerosis & Neurosarcoidosis            |
| Prednisone                    | Multiple sclerosis & Neurosarcoidosis            |
| Amantadine                    | Multiple sclerosis & Parkinson's disease         |
| Methylprednisolone            | Neuralgia  |
| Desvenlafaxine                | Neuralgia  |
| Nortriptyline                 | Neuralgia  |
| Doxorubicin                   | Neuroblastoma                                    |
| Vincristine                   | Neuroblastoma                                    |
| Albendazole                   | Neurocystercosis                                 |
| chloroquine phosphate         | Neurosarcoidosis                                 |
| Hydroxychloroquine            | Neurosarcoidosis                                 |
| Infliximab                    | Neurosarcoidosis                                 |

| DRUG (generic name)           | DISORDER(S)  |
|-------------------------------|--|
| Pentoxifylline                | Neurosarcoidosis   |
| Thalidomide                   | Neurosarcoidosis   |
| Apomorphine                   | Parkinson's disease  |
| Belladonna                    | Parkinson's disease  |
| Benztropine                   | Parkinson's disease  |
| Biperiden                     | Parkinson's disease  |
| Bromocriptine                 | Parkinson's disease  |
| Carbidopa                     | Parkinson's disease  |
| carbidopa/entacapone/levodopa | Parkinson's disease  |
| carbidopa/levodopa            | Parkinson's disease  |
| Entacapone                    | Parkinson's disease  |
| Levodopa                      | Parkinson's disease  |
| pergolide mesylate            | Parkinson's disease  |
| Pramipexole                   | Parkinson's disease  |
| Procyclidine                  | Parkinson's disease  |
| Rasagiline                    | Parkinson's disease  |
| Ropinirole                    | Parkinson's disease  |
| Rotiotine                     | Parkinson's disease  |
| Scopolamine                   | Parkinson's disease  |
| Tolcapone                     | Parkinson's disease  |
| Trihexyphenidyl               | Parkinson's disease  |
| Selegiline                    | Parkinson's disease  |
| Rivastigmine                  | Parkinson's disease & Alzheimer's disease                                  |
| Anisindione                   | Thromboembolic stroke  |
| Warfarin                      | Thromboembolic stroke  |
| 5-hydroxytryptophan           | Depression & Anxiety & ADHD  |
| Duloxetine                    | Depression & Anxiety & Bipolar disorder                                    |
| Escitalopram                  | Depression & Anxiety & Bipolar disorder                                    |
| Venlafaxine                   | Depression & Anxiety & Bipolar disorder & Autism & Social anxiety disorder |
| Desvenlafaxine                | Depression & Anxiety & PTSD & ADHD   |
| Paroxetine                    | Depression & Anxiety & PTSD & Social anxiety disorder                      |
| fluoxetine/olanzapine         | Depression & Bipolar disorder  |
| l-methylfolate                | Depression & BPD   |
| Amitriptyline                 | Depression & PTSD  |
| Sertraline                    | Depression & PTSD & Bipolar disorder & Social anxiety disorder             |
| Fluvoxamine                   | Depression & PTSD & Social anxiety disorder                                |
| Olanzapine                    | Depression & Schizophrenia & Bipolar disorder                              |
| Paliperidone                  | Depression & Schizophrenia & Bipolar disorder                              |
| Aripiprazole                  | Depression & Schizophrenia & Bipolar disorder & Autism                     |
| Quetiapine                    | Depression & Schizophrenia & PTSD & BPD & Bipolar disorder                 |
| Risperidone                   | Depression & Schizophrenia & PTSD & BPD & Bipolar disorder & Autism        |
| Amisulpride                   | Depression & Social anxiety disorder                                       |
| Chlorpromazine                | Psychosis  |
| Droperidol                    | Psychosis  |

| DRUG (generic name) | DISORDER(S)                              |
|---------------------|--|
| Fluphenazine        | Psychosis                                |
| Periciazine         | Psychosis                                |
| Perphenazine        | Psychosis                                |
| Thiothixene         | Psychosis                                |
| Triflupromazine     | Psychosis                                |
| Haloperidol         | Psychosis & Dementia                     |
| Prazosin            | PTSD                                     |
| Clozapine           | Schizophrenia                            |
| Flupenthixol        | Schizophrenia                            |
| Iloperidone         | Schizophrenia                            |
| Loxapine            | Schizophrenia                            |
| Mesoridazine        | Schizophrenia                            |
| Promazine           | Schizophrenia                            |
| Reserpine           | Schizophrenia                            |
| Thioridazine        | Schizophrenia                            |
| Zuclopenthixol      | Schizophrenia                            |
| Asenapine           | Schizophrenia & Bipolar disorder         |
| Levomepromazine     | Schizophrenia & Bipolar disorder         |
| Ziprasidone         | Schizophrenia & Bipolar disorder         |
| Molindone           | Schizophrenia & Psychosis                |
| Pimozide            | Schizophrenia & Psychosis                |
| Thioridazine        | Schizophrenia & Psychosis                |
| Cytarabine          | Chemotherapy, hematological malignancies |

**[00122]** According to some embodiments, the intrabody fluid transfer system **200** can be configured as an infusate delivery system that is delivered to a patient at an infusion rate in the range of from about 1  $\mu\text{L}/\text{minute}$  to about 3  $\mu\text{L}/\text{minute}$ .

**[00123]** Insertion of the surgical cannula assembly **200** (or any other surgical, e.g., delivery, cannula) can be tracked in near real time by reference to a void in the patient tissue caused by the surgical cannula assembly **200** and reflected in the MR image. In some embodiments, one or more MRI-visible fiducial markers may be provided on the surgical tubular cannula **10**, MR scanned and processed, and displayed on the UI. In some embodiments, components of the surgical cannula assembly **200** may itself be formed of an MRI-visible material, MR scanned and processed, and displayed on the UI.

**[00124]** According to some embodiments, the surgical cannula/plunger assembly **200** may include an embedded intrabody MRI antenna (not shown) that is configured to pick-up MRI signals in local tissue during an MRI procedure. The MRI antenna can be configured to reside on a distal end portion of the surgical cannula. In some embodiments, the antenna has a focal length or signal-receiving length of between about 1-5 cm, and typically is configured to have a viewing length to receive MRI signals from local tissue of between about 1-2.5 cm.

The MRI antenna can be formed as comprising a coaxial and/or triaxial antenna. However, other antenna configurations can be used, such as, for example, a whip antenna, a coil antenna, a loopless antenna, and/or a looped antenna. *See, e.g.*, U.S. Patent Nos. 5,699,801; 5,928,145; 6,263,229; 6,606,513; 6,628,980; 6,284,971; 6,675,033; and 6,701,176, the contents of which are hereby incorporated by reference as if recited in full herein. *See also* U.S. Patent Application Publication Nos. 2003/0050557; 2004/0046557; and 2003/0028095, the contents of which are also hereby incorporated by reference as if recited in full herein.

**[00125]** While the devices have been described by way of example as delivery devices and methods for delivering a substance to a patient, in accordance with some embodiments of the invention, the devices can be used to withdraw and/or aspirate a substance (e.g., spinal fluid, cardiac fluid or neuro fluid) from a patient. Thus, it will be appreciated that the devices and methods as disclosed herein can be used to transfer a substance into and/or from a patient.

**[00126]** While the devices have been described herein primarily with reference to MRI-guided insertion and infusion procedures, in some embodiments the devices can be used in procedures without MRI guidance, such as using other imaging modalities, such as, but not limited to, CT imaging systems, where image-guided surgical navigation is desired.

**[00127]** While the cannula/plunger assembly **200** has been described with the surgical assembly **200** coupled to a trajectory guide **1250t**, other types of trajectory guidance or stereotactic frames or without a stereotactic frame or trajectory guide.

**[00128]** **FIG. 15** is a flow chart of exemplary actions that can be carried out according to embodiments of the present invention. A cannula assembly having a luer connector on a proximal end thereof and having a longitudinally opposing distal end is provided (block **600**). A plunger assembly that is coupleable to or coupled to the cannula assembly is provided. The plunger assembly comprises a stylet extending from the proximal end to a position proximate, flush with or beyond the distal end of the cannula assembly (block **610**). A target fluid is intaken into the distal end of the cannula assembly about the stylet in a fluid/flow channel created/defined by the stylet and the cannula assembly (block **620**). The cannula assembly and the plunger assembly can cooperate to generate a vacuum that causes the fluid to be intaken into the distal end portion and upstream thereof (but typically below the plunger luer hub).

[00129] The plunger assembly can comprise a drive screw residing at least partially inside a support body and coupled to the stylet and a collar rotatably coupled to the drive screw configured to retract and extend the stylet (block 617).

[00130] The cannula assembly with the plunger assembly coupled thereto and holding the fluid can be placed into a trajectory guide of a surgical navigation system whereby the plunger flange is above the trajectory guide and the distal end of the cannula assembly and stylet are in a body of a patient (block 622).

[00131] The fluid can be delivered to a target intrabrain location by pushing a plunger toward the distal end of the cannula assembly and dispensing the intaken fluid (block 624).

[00132] The plunger assembly comprises a plunger flange allowing a user to push and pull the plunger to intake and dispense the fluid (block 625).

[00133] The plunger assembly is configured to extend to (concurrently) extend out of the proximal and distal ends of the cannula assembly (block 611) (during at least the delivery/dispensing operation).

[00134] A luer connector of the plunger assembly can be connected to the luer connector of the cannula assembly (block 613).

[00135] The plunger assembly comprises an internal seal at the luer connector and the stylet merges into a plunger segment or drive screw inside a support body (block 614).

[00136] The plunger segment can have a first segment of a first cross-section size and a second segment of a larger cross-sectional size, optionally the first segment is a stylet and the second segment can be defined by a sleeve affixed to the stylet (block 615).

[00137] The fluid comprises stem cells (block 627).

[00138] The foregoing is illustrative of the present invention and is not to be construed as limiting thereof. Although a few exemplary embodiments of this invention have been described, those skilled in the art will readily appreciate that many modifications are possible in the exemplary embodiments without materially departing from the teachings and advantages of this invention. Accordingly, all such modifications are intended to be included within the scope of this invention as defined in the claims. The invention is defined by the following claims, with equivalents of the claims to be included therein.

THAT WHICH IS CLAIMED IS:

1. A surgical plunger assembly comprising:  
a stylet comprising opposing proximal and distal ends;  
a luer connector comprising an internal seal coupled to the stylet; and  
a support body coupled to the luer connector and extending above the distal end of the stylet,  
wherein the support body encloses a sub-length of the stylet,  
wherein the stylet is longitudinally moveable relative to the support body between first and second positions, wherein, in the first position, the proximal end of the stylet is closer to the luer connector than in the second position.
2. The plunger assembly of Claim 1, further comprising a plunger comprising a first segment coupled to or defined by the stylet and a second segment having a greater cross-sectional size than the first segment, wherein the second segment merges into an external plunger flange, wherein the support body encloses the first segment and at least a portion of the second segment and the first segment and the second segment are longitudinally movable relative to the support body, and wherein with the plunger in a first position, the stylet is in the first position and the second segment of the stylet resides closer to the luer connector than when the stylet is in the second position.
3. The plunger assembly of Claim 1, wherein the stylet has a length outside the support body that is in a range of 6 inches and 10 feet.
4. The plunger assembly of Claim 1, wherein the stylet comprises an MRI compatible material and has a maximal outer diameter in a range of about 0.005 inches and about 0.020 inches.
5. The plunger assembly of Claim 4, wherein the stylet comprises Nitinol.
6. The plunger assembly of Claim 4, wherein the stylet comprises fused silica.
7. The plunger assembly of Claim 1, further comprising a drive screw that resides at

least partially in the support body and that is coupled to the proximal end of the stylet.

8. The plunger assembly of Claim 7, further comprising a collar that is coupled to the support body and the drive screw, wherein the collar is rotatable in clockwise and counterclockwise directions to translate the stylet.

9. The plunger assembly of Claim 2, further comprising a support tube residing inside the support body and coupled to the luer connector above the seal, wherein the stylet is slidably coupled to the support tube to retract and extend inside the support tube while the support body slidably retracts and extends in concert with the stylet about an outer wall of the support tube.

10. An intrabody fluid transfer system comprising:  
a cannula assembly comprising a proximal end with a luer connector and having a longitudinally opposing distal end with an open channel extending therethrough; and  
a plunger assembly coupled to the cannula assembly, the plunger assembly comprising a stylet that extends in the open channel of the cannula assembly to position a distal end of the stylet adjacent the distal end of the cannula assembly, wherein the open channel and the stylet cooperate to define a fluid channel extending from the distal end of the cannula assembly, optionally having a length in a range of about 1 cm to about 30 cm.

11. The intrabody fluid transfer system of Claim 10, wherein, with the stylet in a first position associated with a ready to intake fluid or a fully injected position, the distal end of the stylet extends flush with or out of the distal end of the cannula assembly.

12. The intrabody fluid transfer system of Claim 10, wherein, fluid is held for dispensing to a patient in the fluid channel at a location between the distal end of the cannula assembly and a medial portion of the cannula assembly.

13. The intrabody fluid transfer system of Claim 6, wherein the plunger assembly further comprises a luer connector comprising an internal seal residing adjacent the stylet, wherein the luer connector of the plunger assembly is attached to the luer connector of the cannula assembly; and

a support body coupled to the luer connector of the plunger assembly and extending above the distal end of the stylet.

14. The intrabody fluid transfer system of Claim 13, further comprising a plunger comprising a first segment coupled to or defined by the stylet and a second segment having a greater cross-sectional size than the first segment, wherein the second segment merges into an external plunger flange, wherein the support body encloses the first segment and at least a portion of the second segment and the first segment and the second segment are longitudinally movable relative to the support body, and wherein with the plunger in a first position, the second segment resides closer to the luer connectors than in a second position.

15. The intrabody fluid transfer assembly of Claim 14, further comprising a drive screw that resides at least partially in the support body and that is coupled to the proximal end of the stylet.

16. The intrabody fluid transfer assembly of Claim 15, further comprising a collar that is coupled to the support body and the drive screw, wherein the collar is rotatable in clockwise and counterclockwise directions to translate the stylet.

17. The intrabody fluid transfer assembly of Claim 13, further comprising a support tube residing inside the support body and coupled to the luer connector above the seal, wherein the stylet is slidably coupled to the support tube to retract and extend inside the support tube while the support body slidably retracts and extends in concert with the stylet about an outer wall of the support tube.

18. The intrabody fluid transfer system of Claim 13, wherein the stylet has a length outside the support body that is in a range of 6 inches and 10 feet.

19. The intrabody fluid transfer system of Claim 13, wherein the stylet comprises an MRI compatible material and has a maximal outer diameter in a range of about 0.005 inches and about 0.020 inches.

20. The intrabody fluid transfer system of Claim 13, wherein the stylet comprises Nitinol.

21. The intrabody fluid transfer system of Claim 13, wherein the stylet comprises fused silica.

22. A method for transferring fluid into or from a subject, comprising:  
providing a cannula assembly having a luer connector on a proximal end thereof and having a longitudinally opposing distal end;  
providing a plunger assembly that is coupleable to or coupled to the cannula assembly, wherein the plunger assembly comprises a stylet extending from the proximal end to a position proximate, flush with or beyond the distal end of the cannula assembly;  
creating a vacuum by withdrawing the stylet relative to the distal end of the cannula assembly; and  
intaking target fluid into the distal end of the cannula assembly in response to the vacuum created by the stylet and the cannula assembly.

23. The method of Claim 22, placing the cannula assembly with the plunger assembly coupled thereto and holding the fluid into a trajectory guide of a surgical navigation system whereby a proximal end portion of the plunger assembly is above the trajectory guide and the distal end of the cannula assembly and stylet are in a body of a patient and transferring the fluid into the patient.

24. The method of Claim 22, wherein the fluid comprises stem cells.

25. The method of Claim 24, further comprising delivering the fluid to an intrabrain target site for the transferring step.

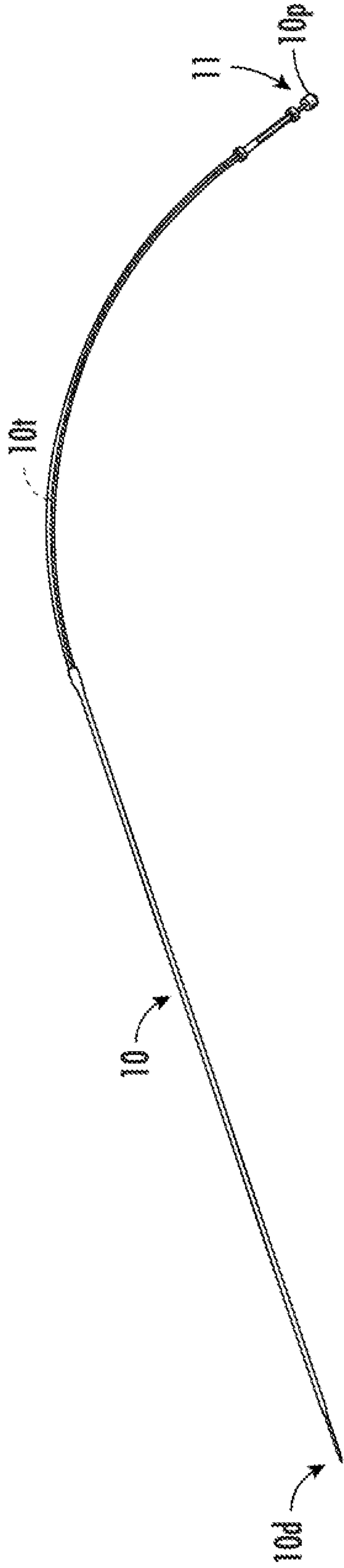

FIG. 1

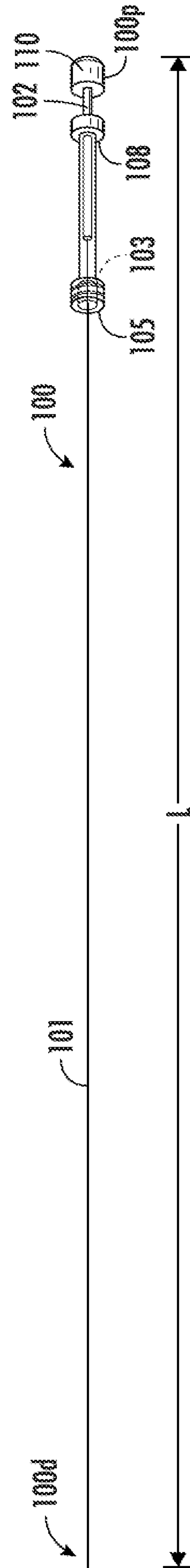

FIG. 2

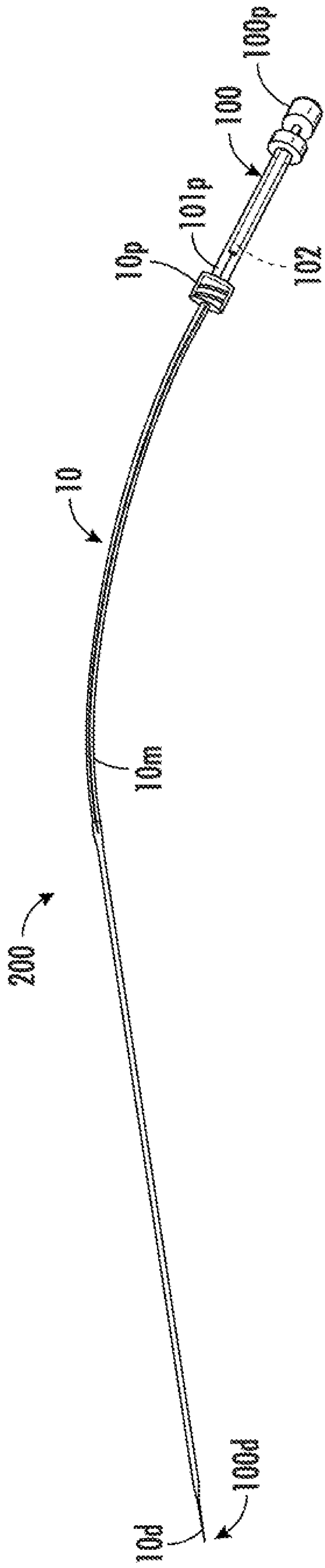

FIG. 3

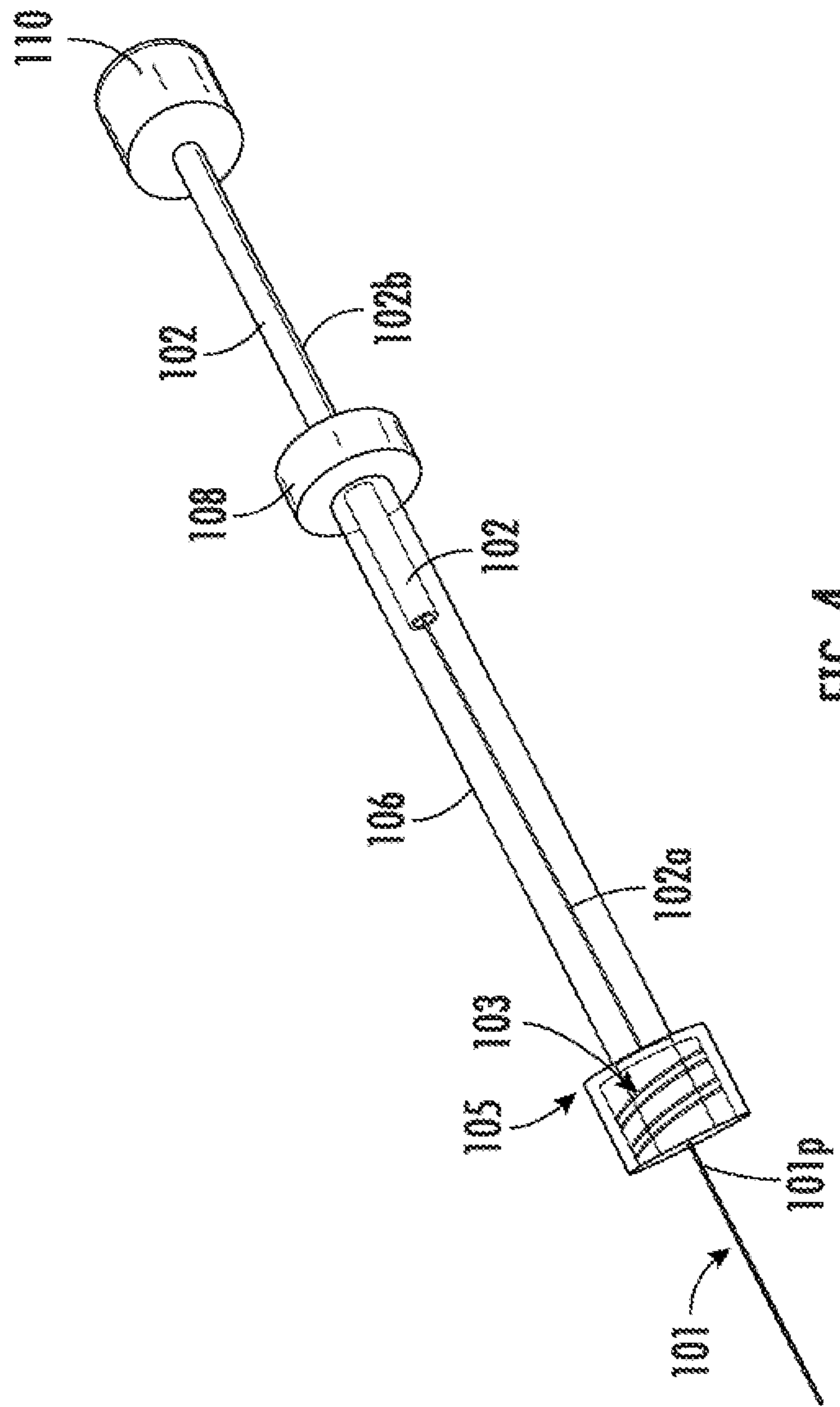
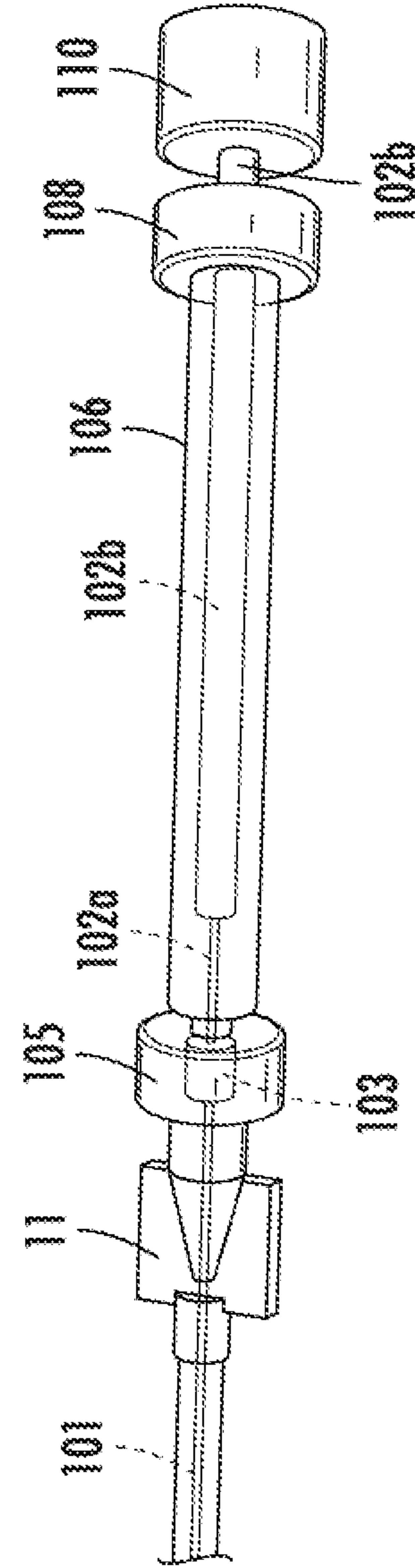
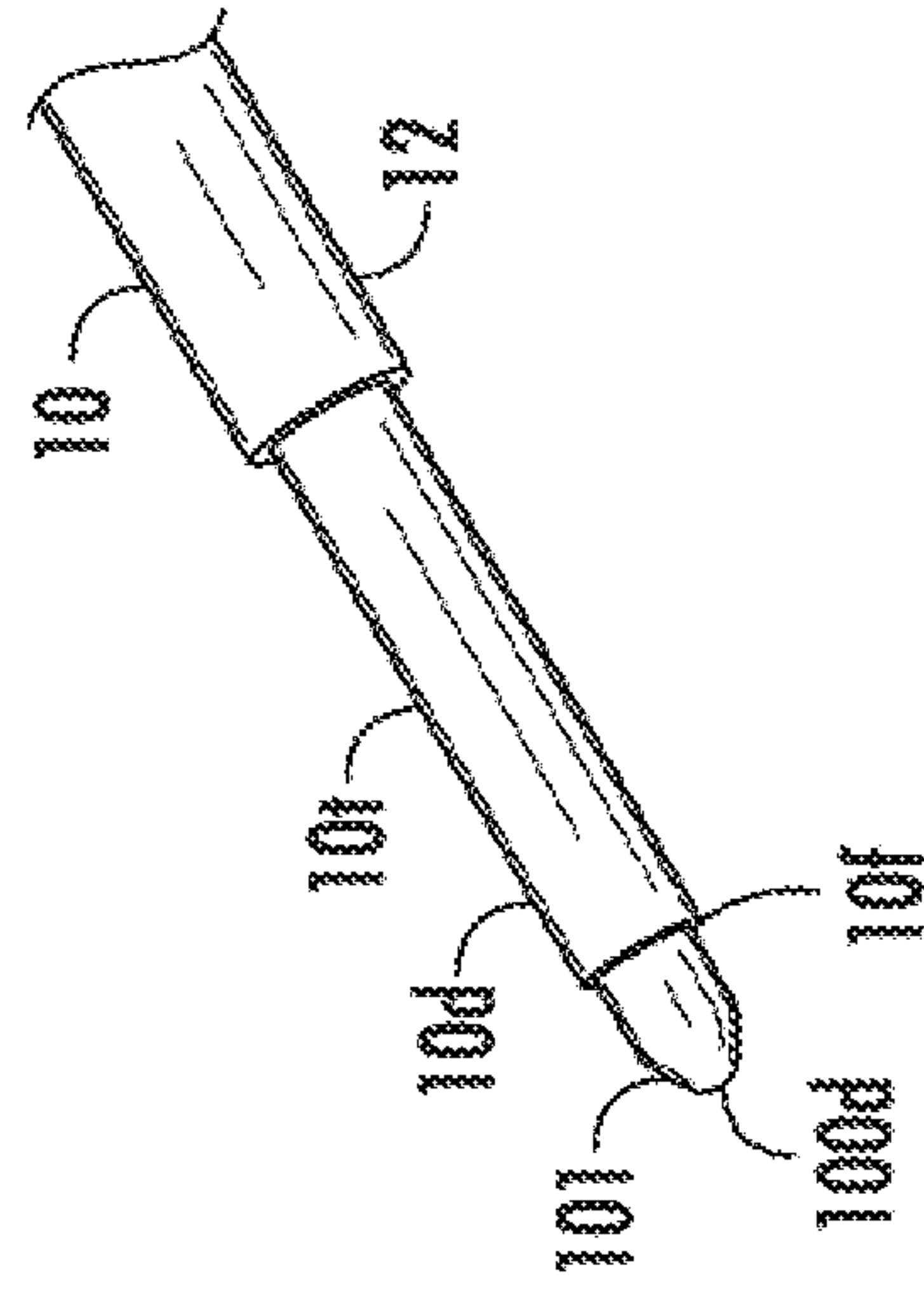
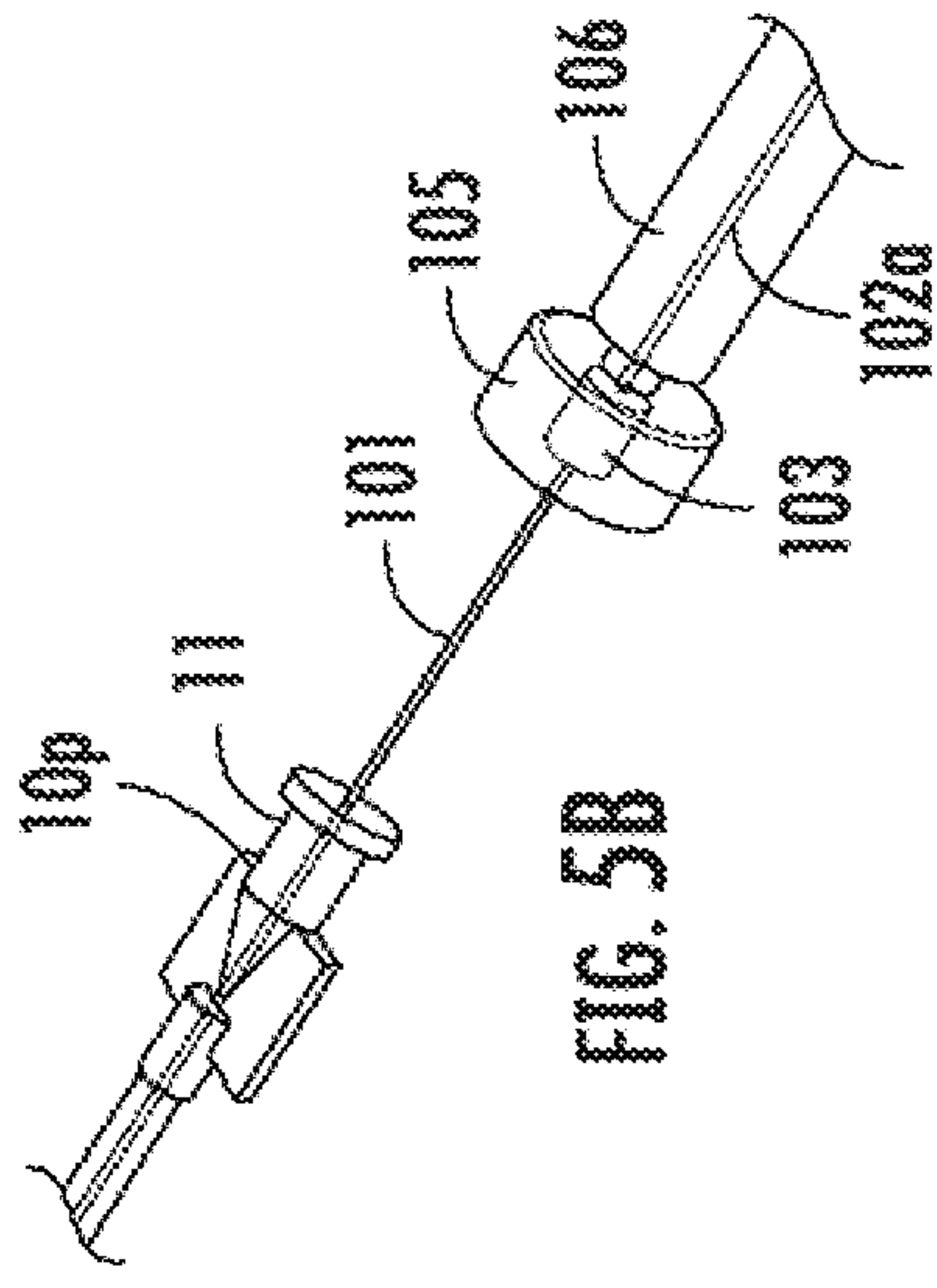
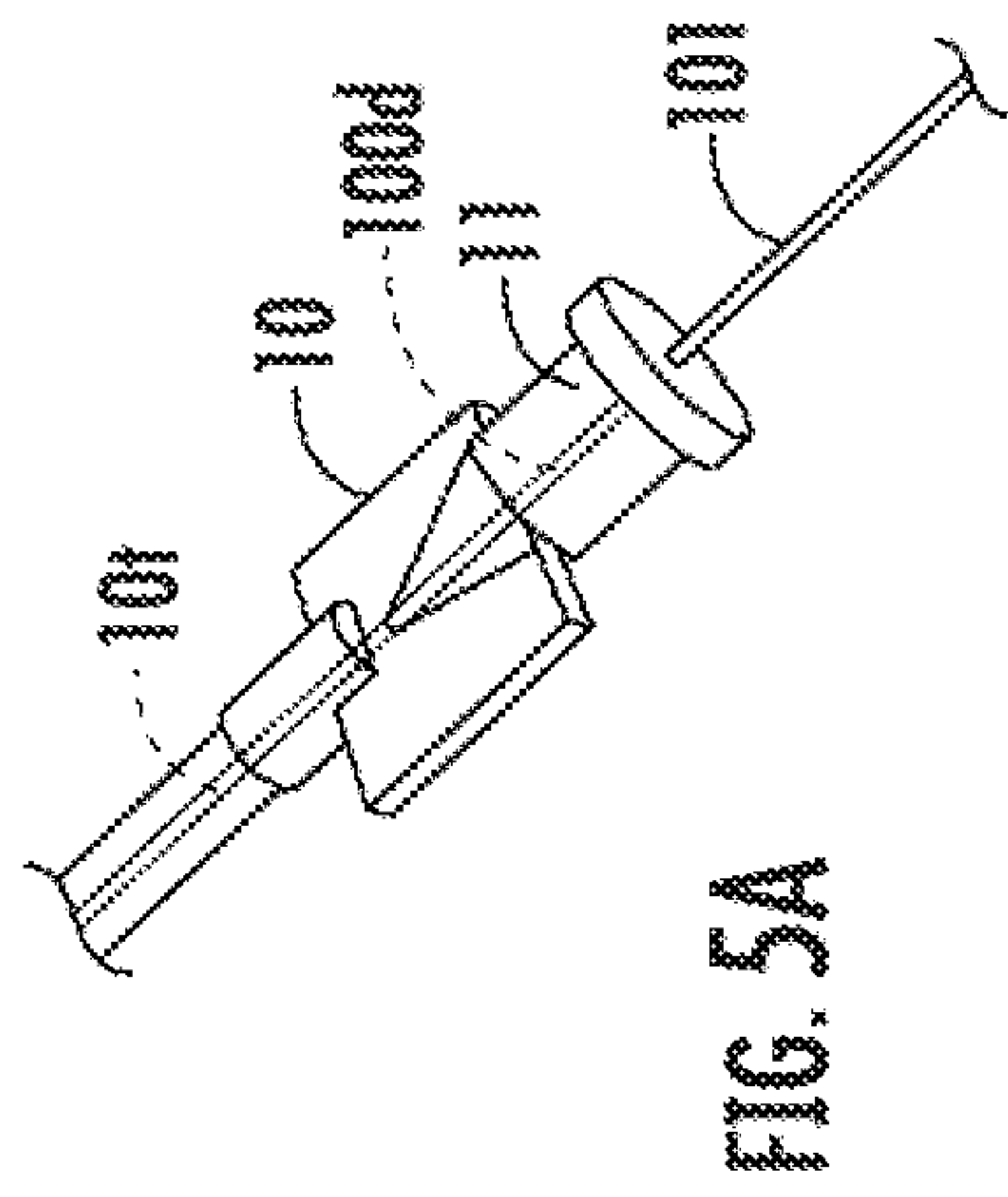

FIG. 4



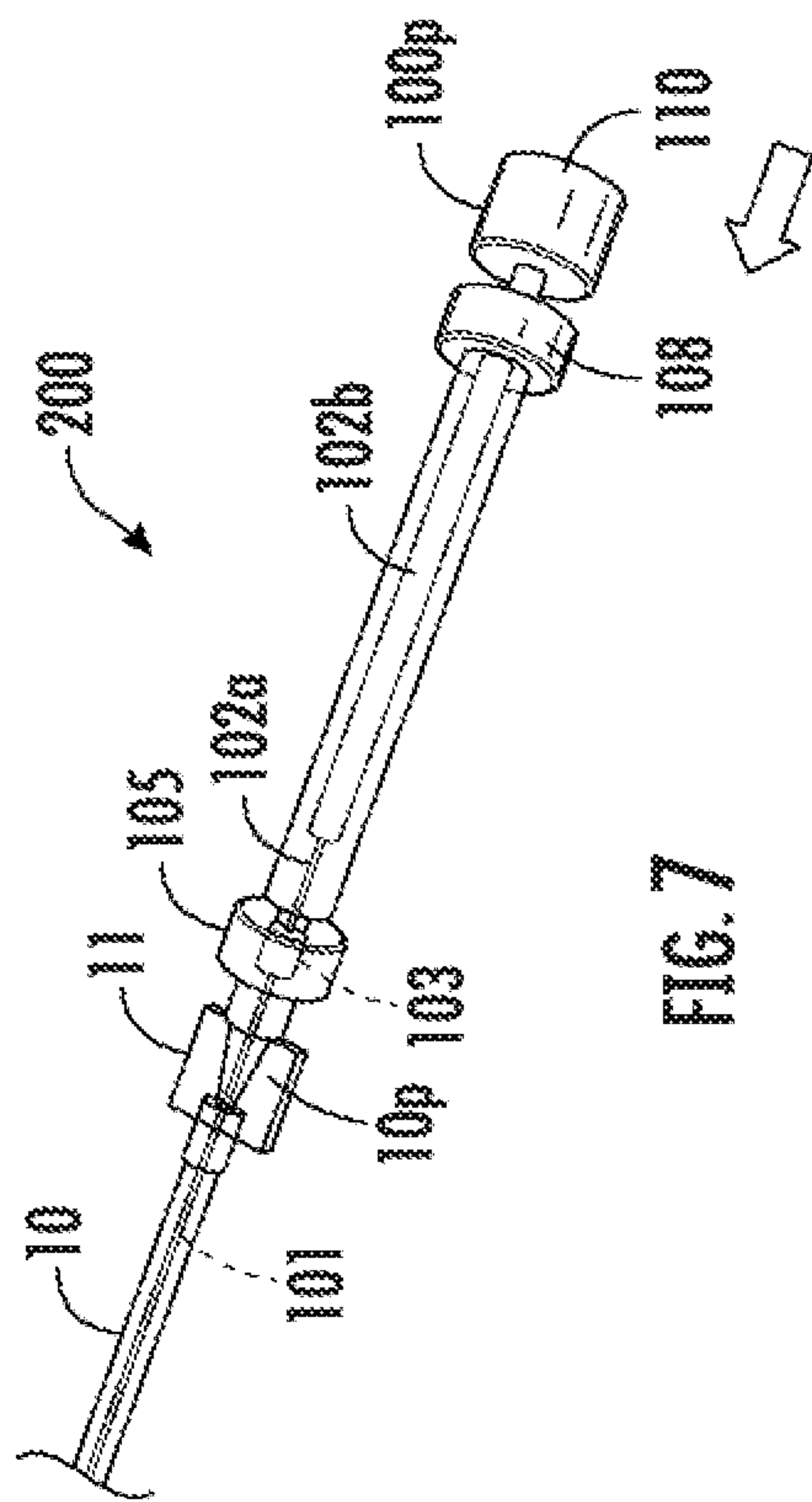

FIG. 7

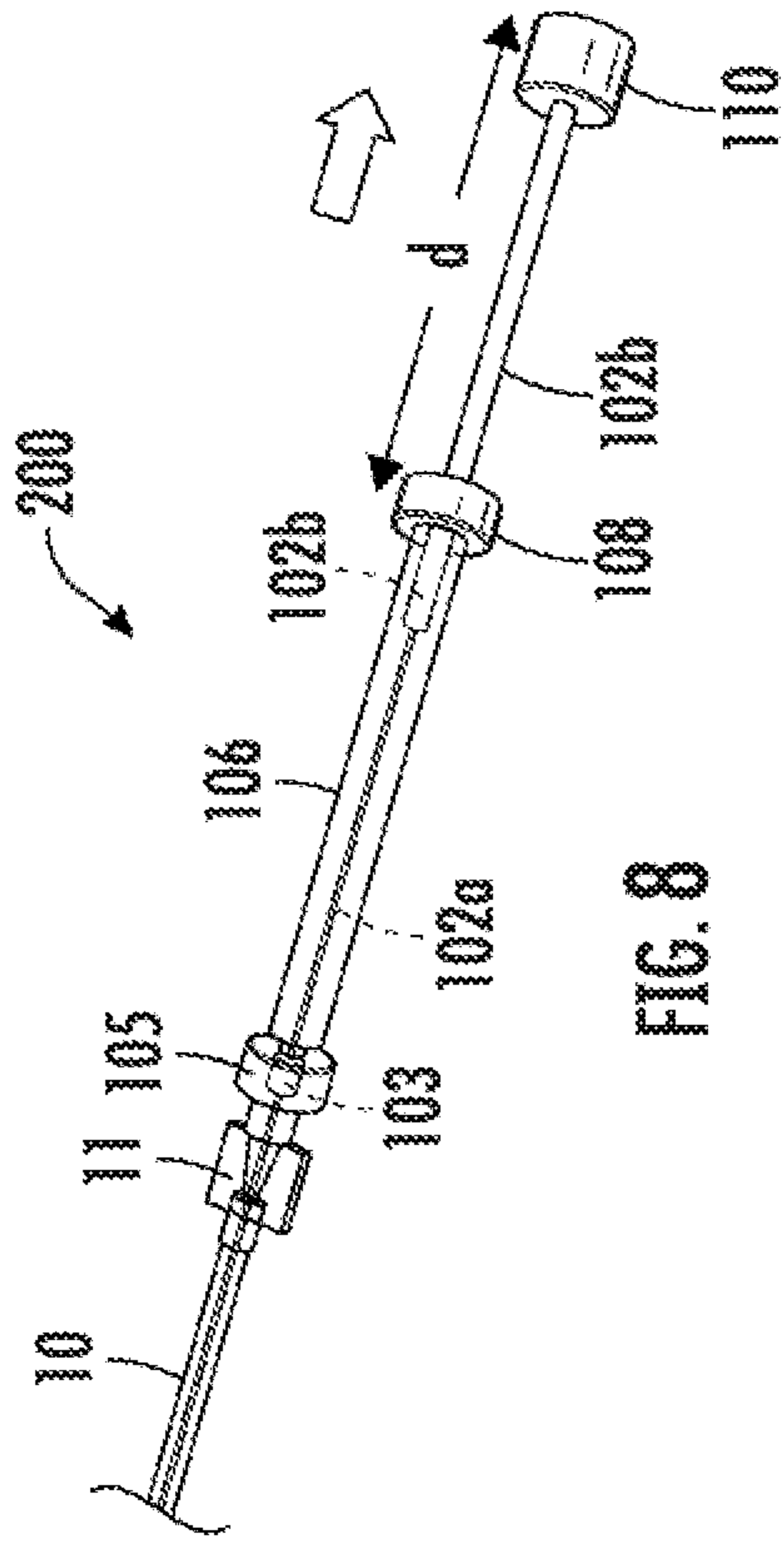

FIG. 8

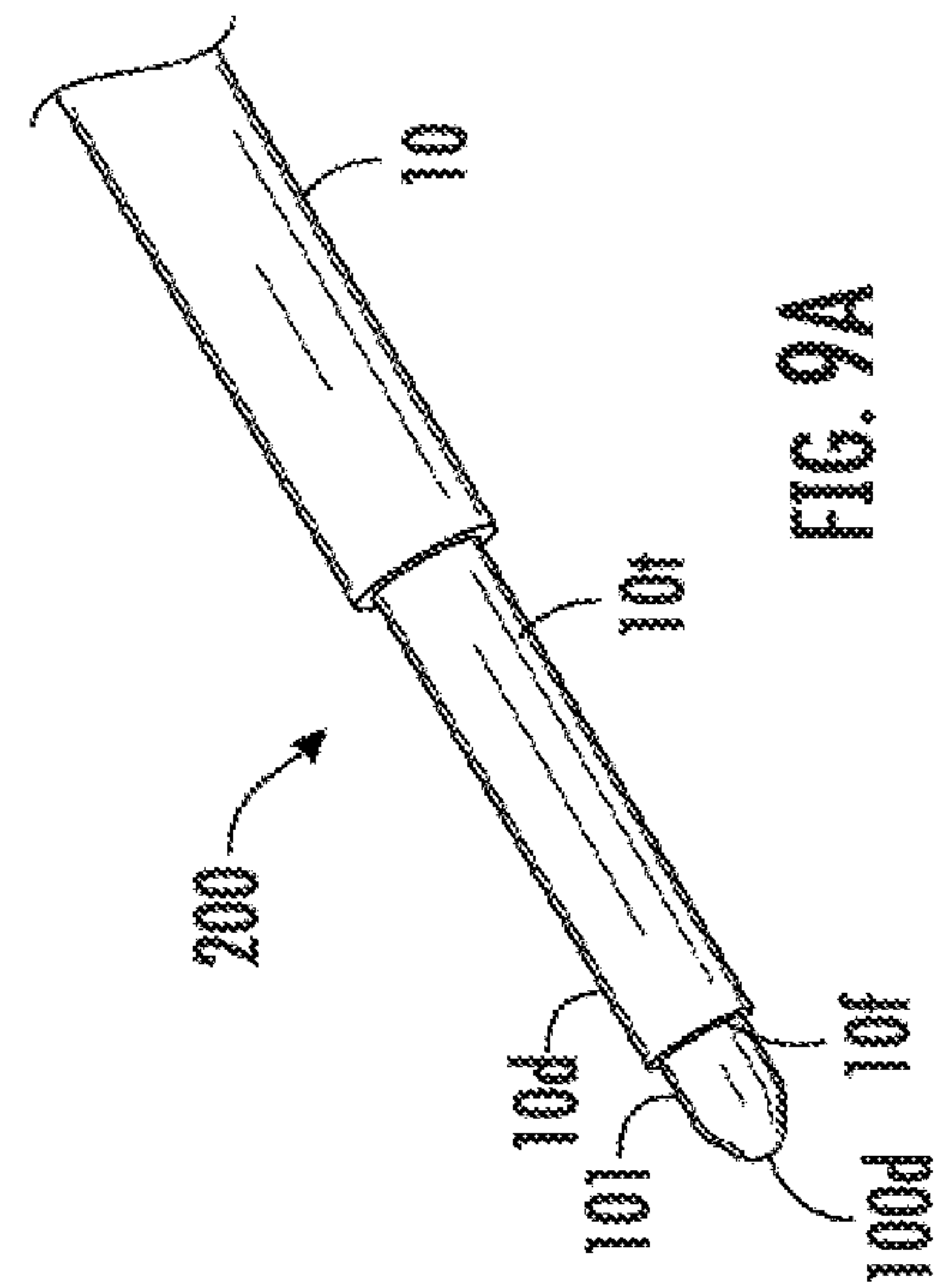

FIG. 9A

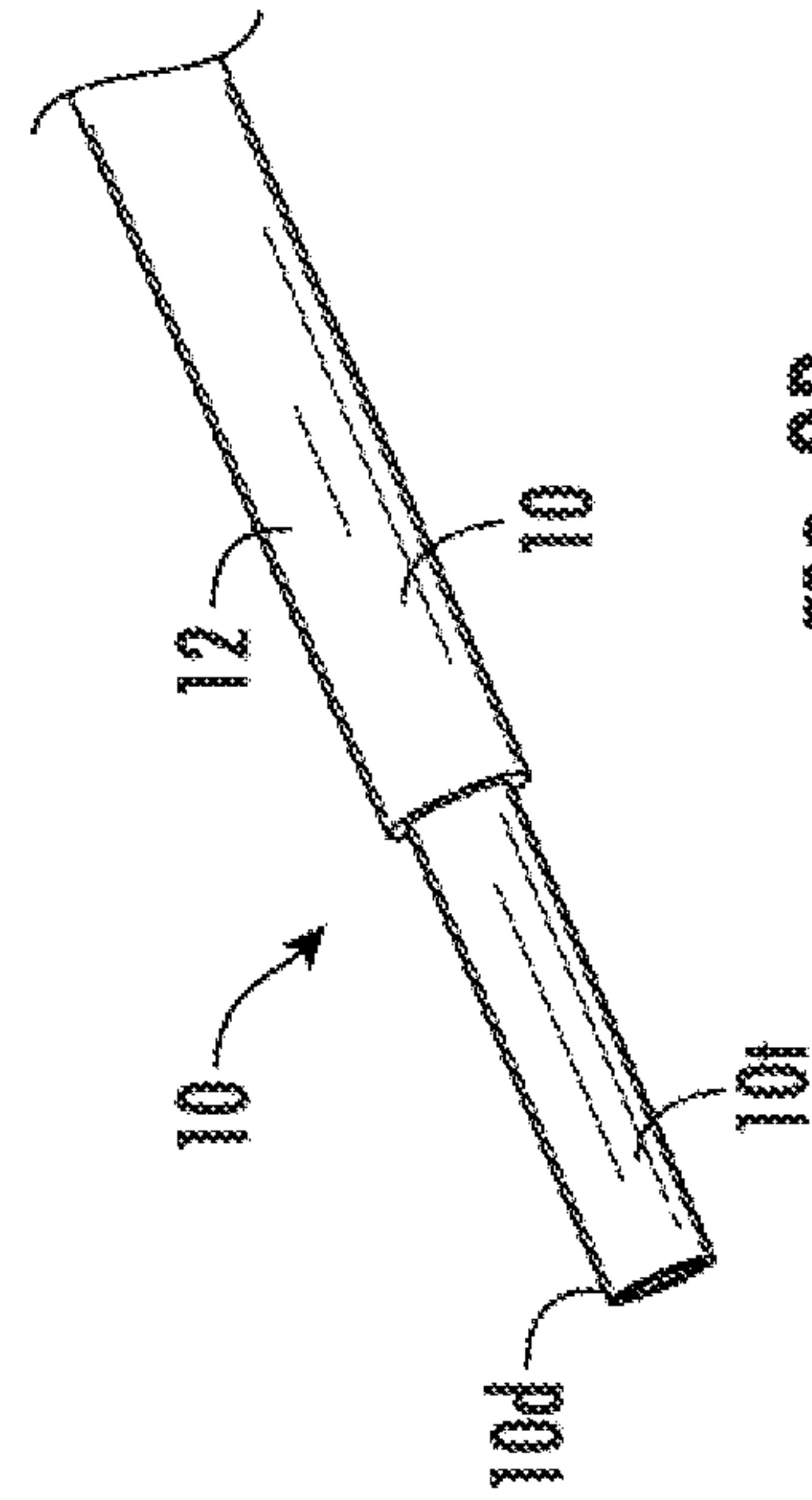
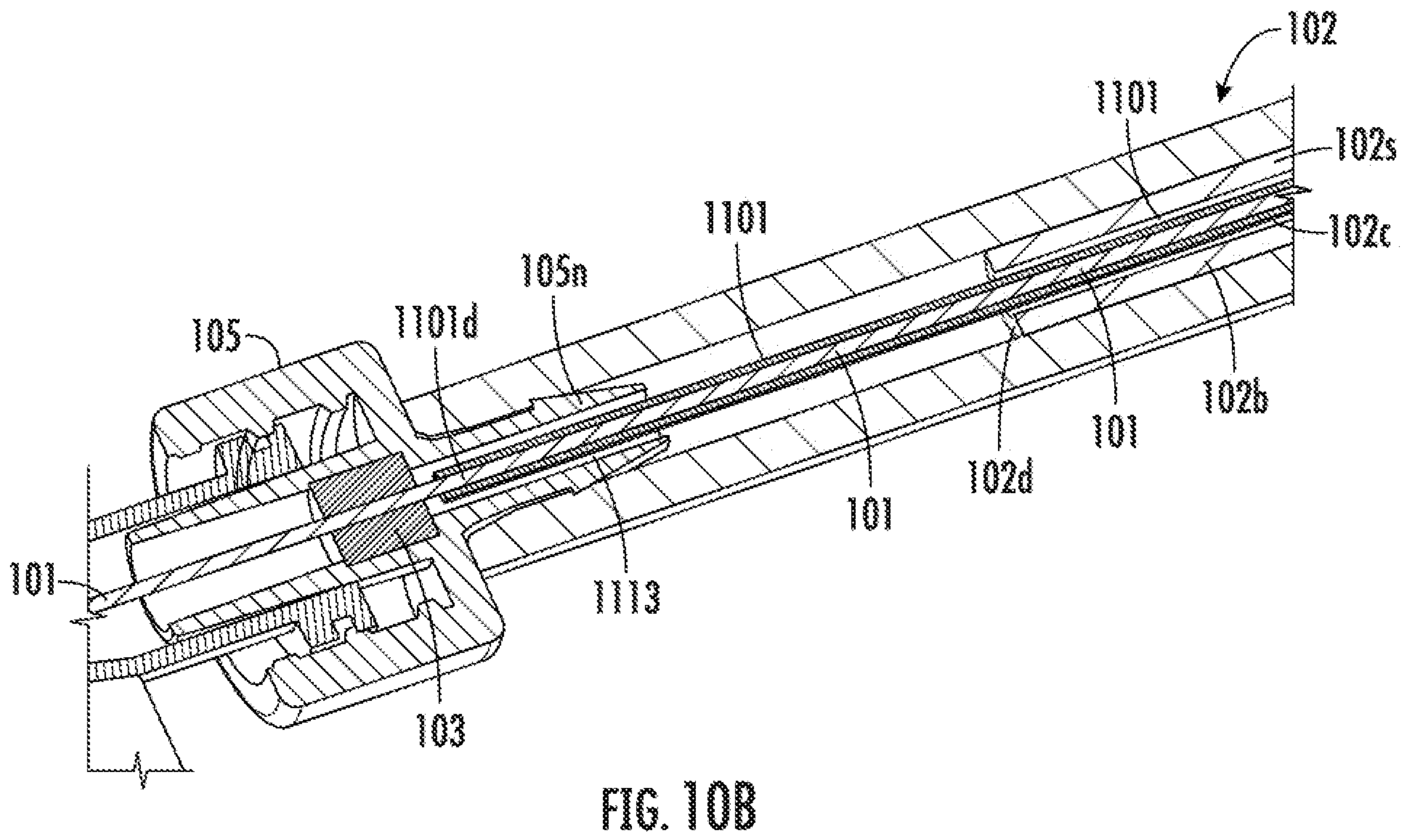
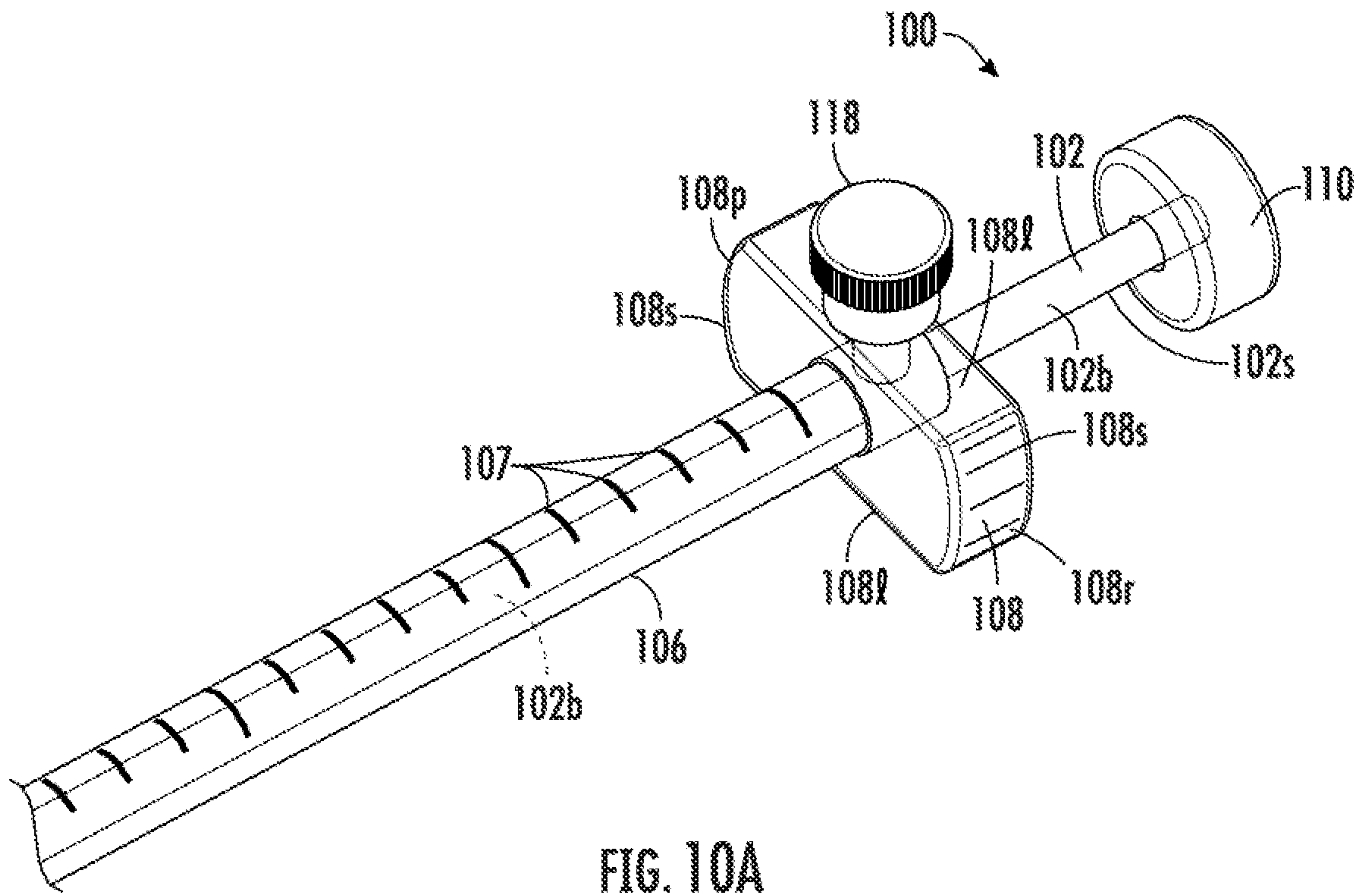

FIG. 9B



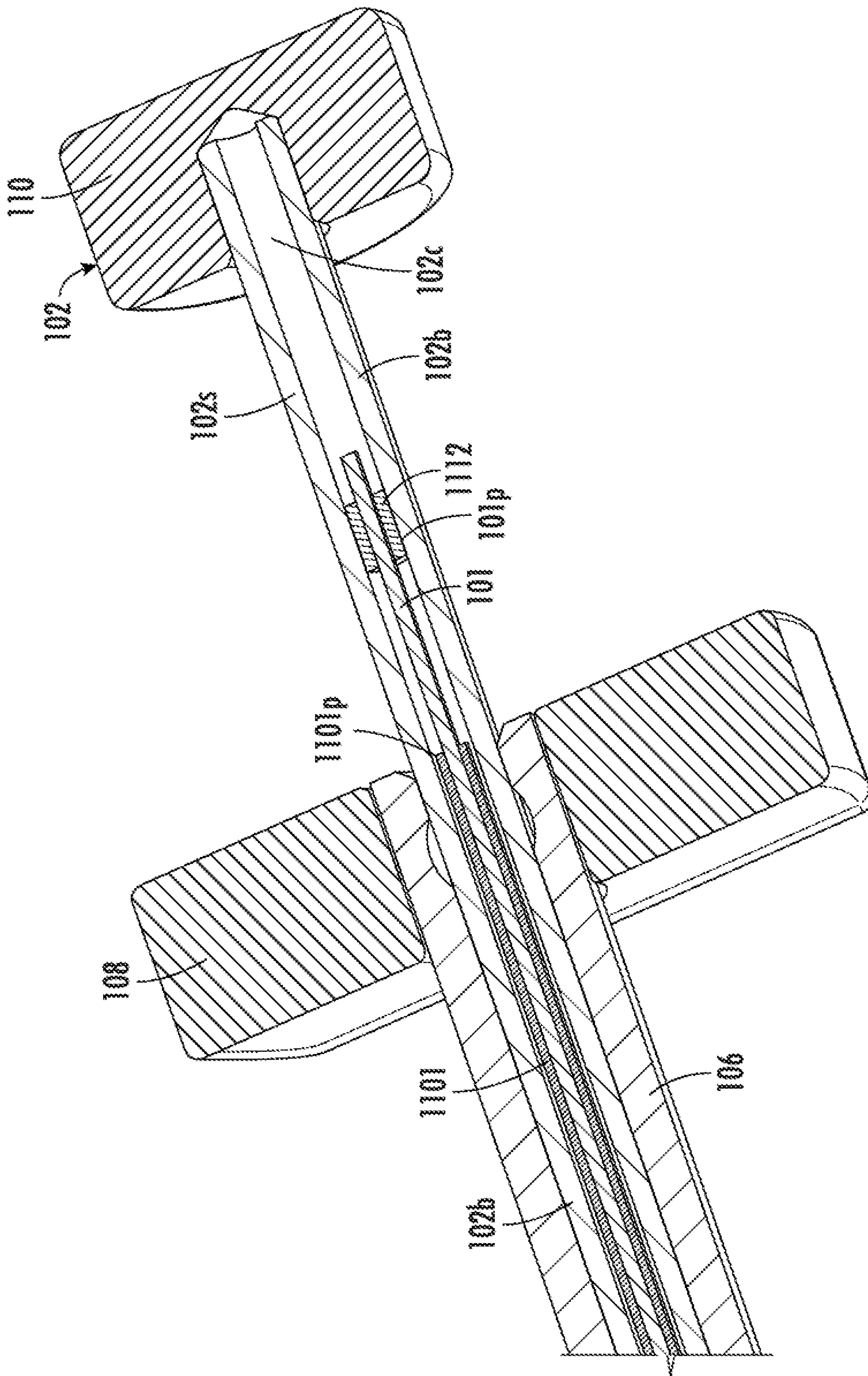

FIG. 10C

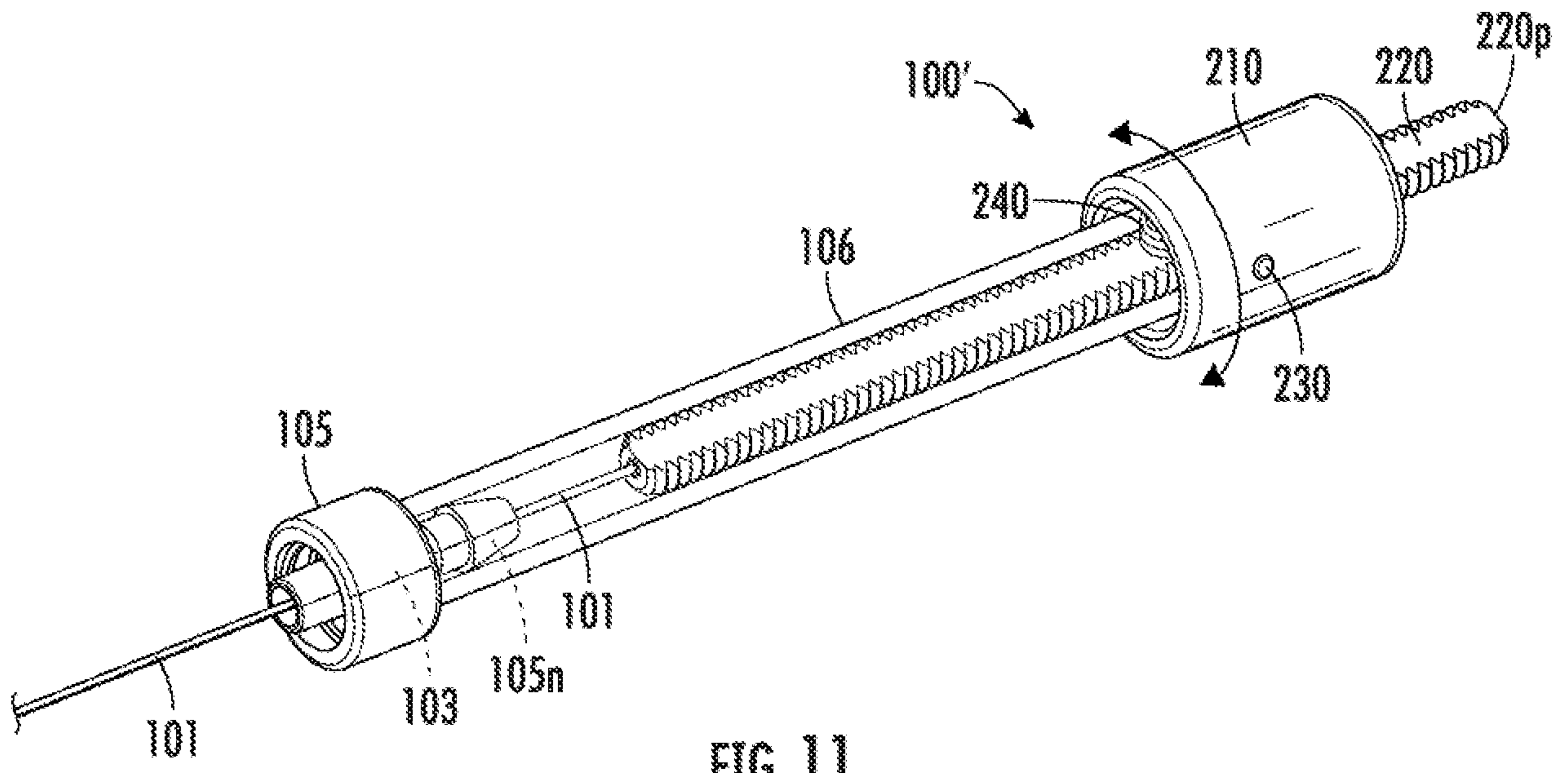

FIG. 11

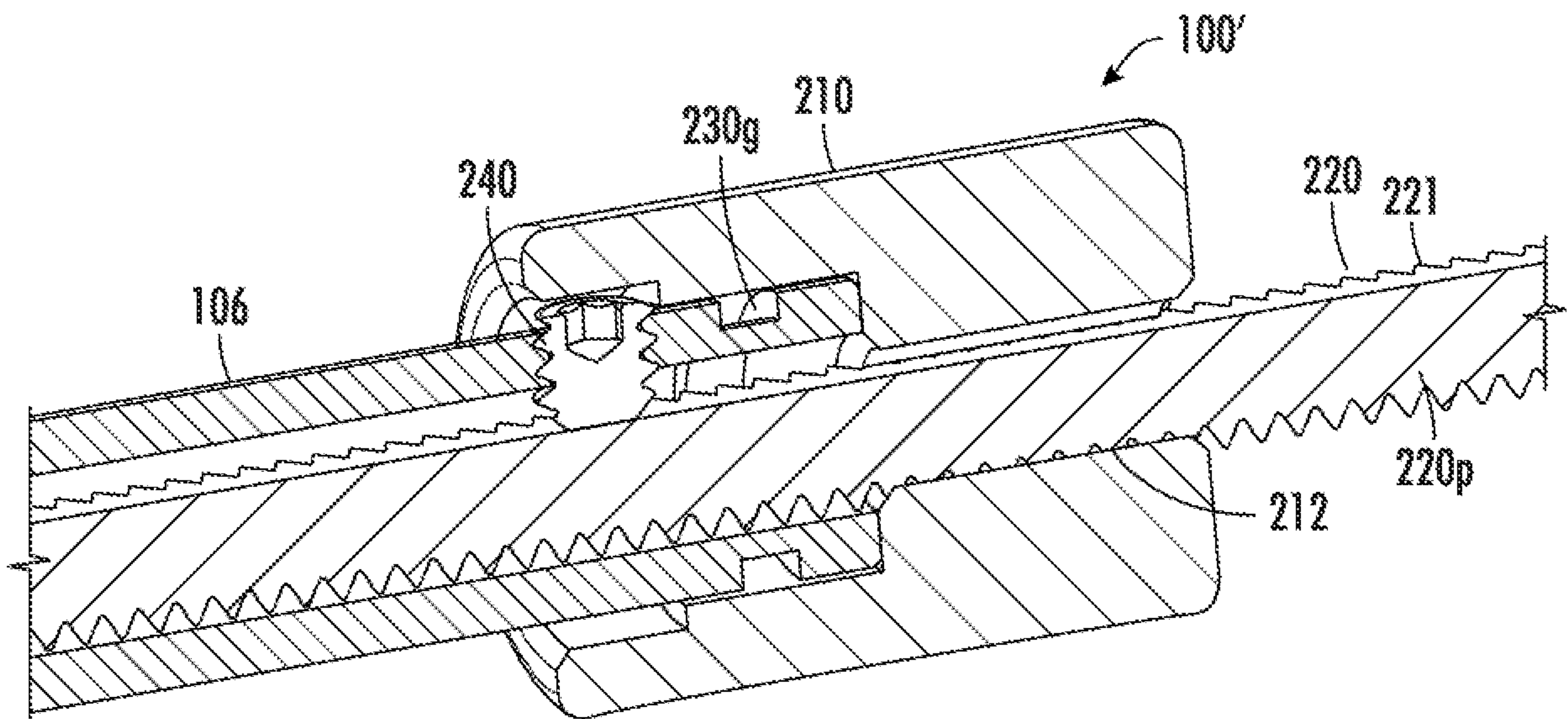

FIG. 12

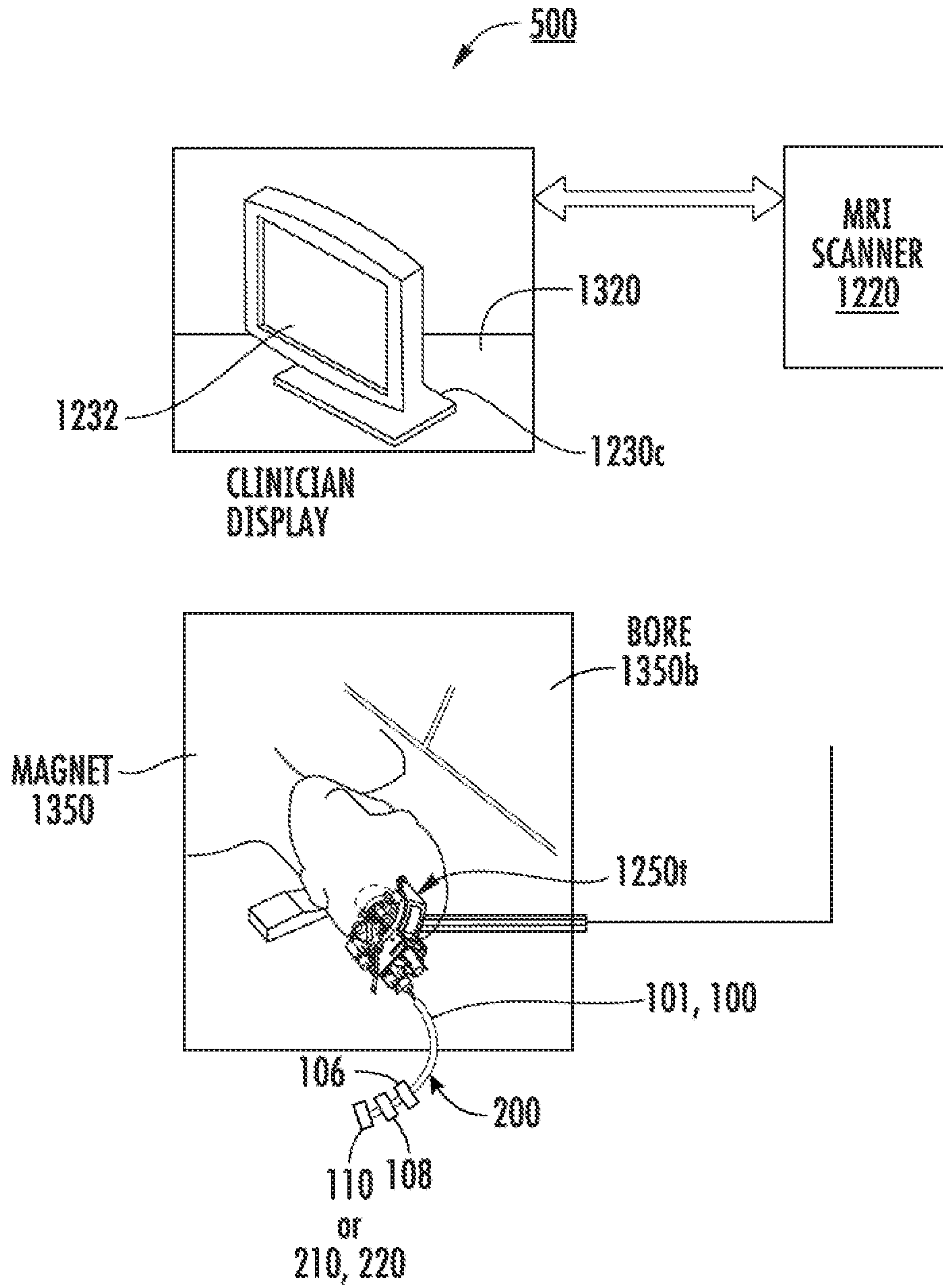

FIG. 13

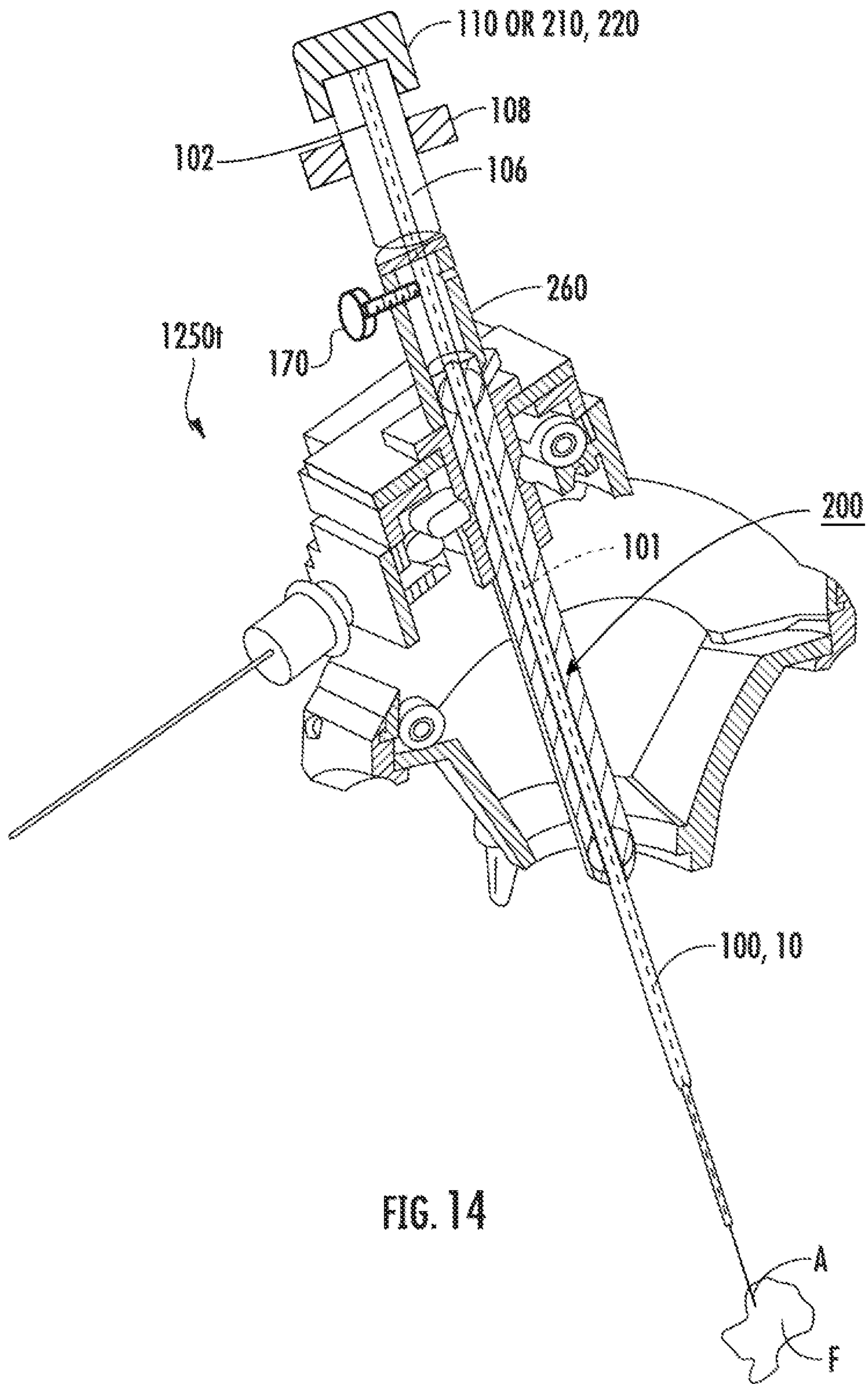

FIG. 14

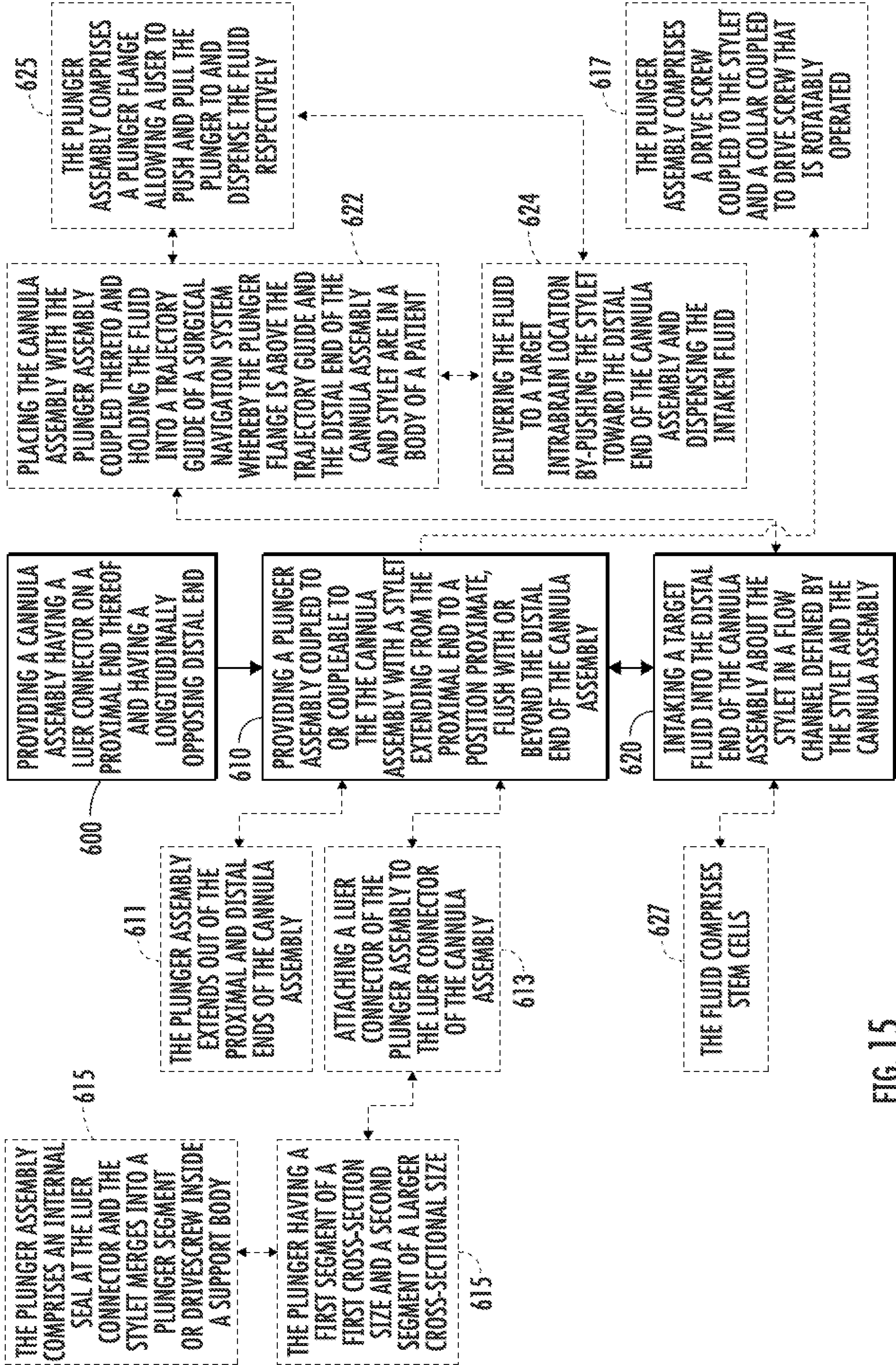

FIG. 15

**INTERNATIONAL SEARCH REPORT**

|   |
|---|
| International application No<br>PCT/US2020/052707 |
|---|

**A. CLASSIFICATION OF SUBJECT MATTER**  
 INV. A61B17/34 A61B90/11  
 ADD.  
 According to International Patent Classification (IPC) or to both national classification and IPC

**B. FIELDS SEARCHED**  
 Minimum documentation searched (classification system followed by classification symbols)  
 A61B  
 Documentation searched other than minimum documentation to the extent that such documents are included in the fields searched

Electronic data base consulted during the international search (name of data base and, where practicable, search terms used)  
 EPO-Internal

**C. DOCUMENTS CONSIDERED TO BE RELEVANT**

| Category* | Citation of document, with indication, where appropriate, of the relevant passages   | Relevant to claim No.          |
|-----------|--|--------------------------------|
| X         | US 4 955 863 A (WALKER JACK M [US] ET AL)<br>11 September 1990 (1990-09-11)  | 1,2,5,<br>9-14,17,<br>20       |
| Y         | column 8, lines 18-36; figures 1,2<br>column 9, lines 50-68  | 3,4,6-8,<br>15,16,<br>18,19,21 |
| Y         | -----<br>US 2017/232229 A1 (FLORES JESSE [US] ET AL) 17 August 2017 (2017-08-17)<br><br>paragraphs [0103] - [0105], [0141], [0142]; figure 11a | 3,4,6-8,<br>15,16,<br>18,19,21 |
| A         | -----<br>US 9 891 296 B2 (MRI INTERVENTIONS INC [US]) 13 February 2018 (2018-02-13)<br>column 8, lines 18-34<br><br>-----<br>-/--              | 1-21                           |

Further documents are listed in the continuation of Box C.  See patent family annex.

\* Special categories of cited documents :

|   |  |
|---|--|
| "A" document defining the general state of the art which is not considered to be of particular relevance  | "T" later document published after the international filing date or priority date and not in conflict with the application but cited to understand the principle or theory underlying the invention  |
| "E" earlier application or patent but published on or after the international filing date   | "X" document of particular relevance; the claimed invention cannot be considered novel or cannot be considered to involve an inventive step when the document is taken alone   |
| "L" document which may throw doubts on priority claim(s) or which is cited to establish the publication date of another citation or other special reason (as specified) | "Y" document of particular relevance; the claimed invention cannot be considered to involve an inventive step when the document is combined with one or more other such documents, such combination being obvious to a person skilled in the art |
| "O" document referring to an oral disclosure, use, exhibition or other means  | "&" document member of the same patent family  |
| "P" document published prior to the international filing date but later than the priority date claimed  |  |

|  |  |
|--|--|
| Date of the actual completion of the international search<br><br>2 December 2020 | Date of mailing of the international search report<br><br>11/12/2020 |
|--|--|

|  |                                      |
|--|--------------------------------------|
| Name and mailing address of the ISA/<br>European Patent Office, P.B. 5818 Patentlaan 2<br>NL - 2280 HV Rijswijk<br>Tel. (+31-70) 340-2040,<br>Fax: (+31-70) 340-3016 | Authorized officer<br><br>Lee, Ronan |
|--|--------------------------------------|

# INTERNATIONAL SEARCH REPORT

International application No.  
PCT/US2020/052707

## Box No. II Observations where certain claims were found unsearchable (Continuation of item 2 of first sheet)

This international search report has not been established in respect of certain claims under Article 17(2)(a) for the following reasons:

1.  Claims Nos.: 22-25  
because they relate to subject matter not required to be searched by this Authority, namely:  
**see FURTHER INFORMATION sheet PCT/ISA/210**
2.  Claims Nos.:  
because they relate to parts of the international application that do not comply with the prescribed requirements to such an extent that no meaningful international search can be carried out, specifically:
3.  Claims Nos.:  
because they are dependent claims and are not drafted in accordance with the second and third sentences of Rule 6.4(a).

## Box No. III Observations where unity of invention is lacking (Continuation of item 3 of first sheet)

This International Searching Authority found multiple inventions in this international application, as follows:

1.  As all required additional search fees were timely paid by the applicant, this international search report covers all searchable claims.
2.  As all searchable claims could be searched without effort justifying an additional fees, this Authority did not invite payment of additional fees.
3.  As only some of the required additional search fees were timely paid by the applicant, this international search report covers only those claims for which fees were paid, specifically claims Nos.:
4.  No required additional search fees were timely paid by the applicant. Consequently, this international search report is restricted to the invention first mentioned in the claims; it is covered by claims Nos.:

### Remark on Protest

- The additional search fees were accompanied by the applicant's protest and, where applicable, the payment of a protest fee.
- The additional search fees were accompanied by the applicant's protest but the applicable protest fee was not paid within the time limit specified in the invitation.
- No protest accompanied the payment of additional search fees.

**FURTHER INFORMATION CONTINUED FROM PCT/ISA/ 210**

Continuation of Box II.1

Claims Nos.: 22-25

The subject-matter of claims 22-25 appears to constitute a surgical procedure on the human body, and therefore under Rule 39.1(iv) PCT (Method for treatment of the human or animal body by surgery), these claims have not been searched. For the same reason, the claims do not require preliminary examination, Rule 67.1 (iv) PCT.

INTERNATIONAL SEARCH REPORT

International application No  
PCT/US2020/052707

C(Continuation). DOCUMENTS CONSIDERED TO BE RELEVANT

| Category* | Citation of document, with indication, where appropriate, of the relevant passages                              | Relevant to claim No. |
|-----------|---|-----------------------|
| A         | EP 2 558 154 A2 (MRI INTERVENTIONS INC [US]) 20 February 2013 (2013-02-20) paragraphs [0138], [0141]<br>-----   | 1-21                  |
| A         | US 2017/151416 A1 (KUTIKOV ARTEM B [US] ET AL) 1 June 2017 (2017-06-01) paragraph [0272]; figures 7-10<br>----- | 1-21                  |

# INTERNATIONAL SEARCH REPORT

Information on patent family members

International application No

PCT/US2020/052707

| Patent document cited in search report | Publication date | Patent family member(s) | Publication date            |
|--|------------------|-------------------------|-----------------------------|
| US 4955863                             | A                | 11-09-1990              | NONE                        |
| -----                                  |                  |                         |                             |
| US 2017232229                          | A1               | 17-08-2017              | EP 3393571 A1 31-10-2018    |
|  |                  |                         | US 2017232229 A1 17-08-2017 |
|  |                  |                         | US 2020147344 A1 14-05-2020 |
|  |                  |                         | WO 2017142698 A1 24-08-2017 |
| -----                                  |                  |                         |                             |
| US 9891296                             | B2               | 13-02-2018              | NONE                        |
| -----                                  |                  |                         |                             |
| EP 2558154                             | A2               | 20-02-2013              | EP 2558154 A2 20-02-2013    |
|  |                  |                         | US 2013030408 A1 31-01-2013 |
|  |                  |                         | US 2015374908 A1 31-12-2015 |
|  |                  |                         | US 2020147299 A1 14-05-2020 |
|  |                  |                         | WO 2011130107 A2 20-10-2011 |
| -----                                  |                  |                         |                             |
| US 2017151416                          | A1               | 01-06-2017              | US 2017151416 A1 01-06-2017 |
|  |                  |                         | WO 2017095753 A1 08-06-2017 |
| -----                                  |                  |                         |                             |