

(19) World Intellectual Property Organization
International Bureau



(43) International Publication Date
22 November 2007 (22.11.2007)

PCT

(10) International Publication Number
WO 2007/134026 A1

- (51) International Patent Classification:
A46B 7/06 (2006.01)
- (21) International Application Number:
PCT/US2007/068435
- (22) International Filing Date: 8 May 2007 (08.05.2007)
- (25) Filing Language: English
- (26) Publication Language: English
- (30) Priority Data:
11/429,677 8 May 2006 (08.05.2006) US
- (71) Applicant (for all designated States except US): COLGATE-PALMOLIVE COMPANY [US/US]; 300 Park Avenue, New York, NY 10022 (US).
- (72) Inventors; and
- (75) Inventors/Applicants (for US only): MOSKOVICH, Robert [US/US]; 20 Jensen Street, East Brunswick, NJ 08816 (US). WAGUESPACK, Kenneth [US/US]; 46 Princess Drive, North Brunswick, NJ 08902 (US). RUSSELL, Bruce, M. [US/US]; 30 Flintlock Drive, Howell, NJ 07731 (US).
- (74) Agent: MORGAN, Michael, F.; Colgate-Palmolive Company, P.O. Box 1343, 909 River Road, Piscataway, NJ 08854 (US).

- (81) Designated States (unless otherwise indicated, for every kind of national protection available): AE, AG, AL, AM, AT, AU, AZ, BA, BB, BG, BH, BR, BW, BY, BZ, CA, CH, CN, CO, CR, CU, CZ, DE, DK, DM, DZ, EC, EE, EG, ES, FI, GB, GD, GE, GH, GM, GT, HN, HR, HU, ID, IL, IN, IS, JP, KE, KG, KM, KN, KP, KR, KZ, LA, LC, LK, LR, LS, LT, LU, LY, MA, MD, MG, MK, MN, MW, MX, MY, MZ, NA, NG, NI, NO, NZ, OM, PG, PH, PL, PT, RO, RS, RU, SC, SD, SE, SG, SK, SL, SM, SV, SY, TJ, TM, TN, TR, TT, TZ, UA, UG, US, UZ, VC, VN, ZA, ZM, ZW.
- (84) Designated States (unless otherwise indicated, for every kind of regional protection available): ARIPO (BW, GH, GM, KE, LS, MW, MZ, NA, SD, SL, SZ, TZ, UG, ZM, ZW), Eurasian (AM, AZ, BY, KG, KZ, MD, RU, TJ, TM), European (AT, BE, BG, CH, CY, CZ, DE, DK, EE, ES, FI, FR, GB, GR, HU, IE, IS, IT, LT, LU, LV, MC, MT, NL, PL, PT, RO, SE, SI, SK, TR), OAPI (BF, BJ, CF, CG, CI, CM, GA, GN, GQ, GW, ML, MR, NE, SN, TD, TG).

- Published:**
- with international search report
 - before the expiration of the time limit for amending the claims and to be republished in the event of receipt of amendments

For two-letter codes and other abbreviations, refer to the "Guidance Notes on Codes and Abbreviations" appearing at the beginning of each regular issue of the PCT Gazette.

(54) Title: ORAL CARE IMPLEMENT

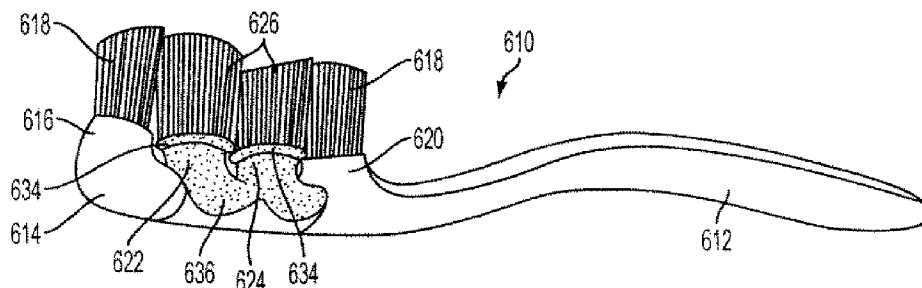

(57) Abstract: An oral care implement (610) is provided having a handle (612) and a head (614) with tooth cleaning elements (618) extending from fixed pods (616, 620). Additional tooth cleaning elements (626) extend from one or more central pods (622, 624) suspended between the fixed pods (616, 620) via a bridge (636). The bridge may be formed from an elastomer and permit the one or more central pods (622, 624) to move from an initial position toward the head during use. The central pods (622, 624), the bridge (636) and outer portions of the fixed pods (616, 620) may be formed as a unitary structure. When a single central pod is employed, a flexible section may be disposed in the middle of the central pod so that cleaning elements extending from either end of the central pod can move toward one another during use.

WO 2007/134026 A1



ORAL CARE IMPLEMENT**CROSS-REFERENCE TO RELATED APPLICATIONS**

[01] This is a continuation in part of U.S. Application 11/256,790, filed October 24, 2005, which is a continuation in part of U.S. Application 11/122,224 filed May 5, 2005, which is a continuation in part of U.S. Application 10/768,363, filed January 30, 2004, which is a continuation in part of U.S. Application 10/697,213, filed October 30, 2003.

[02] Further, this is a continuation in part of U.S. Application 11/019,671, filed December 23, 2004, which: (1) is a continuation in part of U.S. Application 10/869,922, filed June 18, 2004, which is a continuation in part of U.S. Application 10/601,106, filed June 20, 2003; (2) is a continuation in part of International Application PCT/US03/030633 filed September 26, 2003, which claims the benefit of U.S. Application 60/414,117 filed September 27, 2002, U.S. Application 60/418,776, filed October 16, 2002, and U.S. Application 60/419,425, filed October 18, 2002; (3) is a continuation in part of International Application PCT/US2003/029497, filed September 17, 2003, which claims the benefit of U.S. Application 60/412,290, filed September 20, 2002; (4) is a continuation in part of U.S. Application 29/189,729, filed September 10, 2003; and (5) is a continuation-in-part of U.S. Application 10/989,267, filed November 17, 2004, which is a continuation-in-part application of U.S. Application 29/209,242, filed July 14, 2004.

[03] Additionally, this application is a continuation in part application of U.S. Application 10/989,267, filed November 17, 2004, which is a continuation in part application of U.S. Application Serial No. 29/209,242, filed July 14, 2004, and a continuation in part application of U.S. Application 29/209,244, filed July 14, 2004.

[04] Further, this application is a continuation in part application of U.S. Application 10/902,257, 2004, filed July 30, 2004, which (1) is a continuation in part of International Application PCT/US2003/029497, filed September 17, 2003, which claims priority of U.S. Application 60/412,290, filed September 20, 2002; and (2) is a continuation in part of U.S. Application 29/189,729, filed September 10, 2003.

[05] In addition, this application is a continuation in part of U.S. Application 11/053,583, filed February 8, 2005, which is a continuation of International Application PCT/US2003/024878,

filed August 8, 2003, which claims priority to U.S. Applications 60/402,162 filed August 9, 2002, 60/402,170 filed August 9, 2002 and 60/402,670 filed August 12, 2002.

[06] Further, this application is a continuation in part of U.S. Application 11/053,589, filed February 4, 2005, which is a continuation of International Application PCT/US2003/024879, filed August 8, 2003, which claims priority to U.S. Application 60/402,165 filed August 9, 2002.

[07] The contents of the above-noted applications are each expressly incorporated herein by reference.

FIELD OF THE INVENTION

[08] The present invention pertains to an oral care implement having various features that may include a cleaner for cleaning soft tissue surfaces in a user's mouth, tooth cleaning or tooth treating elements, movable cleaning features, vibratory mechanisms, and/or handle gripping features.

BACKGROUND

[09] A variety of toothbrush configurations exist that have stationary and/or mechanically-driven movable cleaning elements. These conventional toothbrushes are dedicated to tooth cleaning/polishing operations and typically include a head portion directed to the cleaning/polishing operations, and a handle portion. The head typically has a flat or slightly altered surface to which the cleaning elements are attached, or to which mechanically-driven movable carriers for the cleaning elements are attached.

[10] Tongue scrapers exist as devices for removing micro debris disposed on a user's tongue. Conventional tongue scrapers are stand-alone devices directed to the singular purpose of scraping a user's tongue. These conventional devices typically include a handle and scraper portion without including other cleaning elements.

[11] Users manipulate conventional toothbrushes and tongue scrapers by grasping their handle portions. The handles are typically simple, linear rods of a relatively rigid material, which are neither comfortable for the user nor given to easy manipulation. As these devices are commonly used in wet conditions, their handles are often slippery during use.

[12] Many people use multiple oral care implements, such as toothbrushes and tongue scrapers, on a daily basis to accomplish multiple oral care tasks. For instance, a user may use a toothbrush to clean his teeth and then use a tongue scraper to remove debris from his tongue. The user may then re-use the toothbrush to further clean his tongue. Thus, the user may switch between various oral care implements during a single session in a wet environment.

[13] Conventional toothbrushes have cleaning elements that extend from a rigid head. Teeth and gums by nature have a complex intricate contour. Due to the rigid nature of the attachment of the cleaning elements to the head of the toothbrush, the orientation of the cleaning elements is not flexible and thus conventional toothbrushes do not provide optimal cleaning of teeth and gums. Conventional toothbrushes therefore have great difficulty in contacting areas of the teeth located at a greater distance from the head, including interproximal spaces between teeth.

SUMMARY

[14] The present invention pertains to an oral care implement that provides several advantages and that may be used for multiple functions. In one embodiment of the invention, an oral care implement is provided that has a plurality of cleaning elements extending from the head, which are attached to a support that is flexibly attached to the head. The cleaning elements may include forward angled cleaning elements and/or rearward angled cleaning elements. The cleaning elements may further include a central support at a central portion of the support.

[15] Embodiments of the invention may be multi-functional and include various combinations of features in advantageous combinations. Some embodiments include a soft tissue cleaner in combination with tooth cleaning features and/or in combination with gripping features on the handle that improve the user's grip and handling thereof. The embodiments may be manual or mechanically-driven devices, or combinations thereof.

BRIEF DESCRIPTION OF THE DRAWINGS

[16] A more complete understanding of the present invention and the advantages thereof may be acquired by referring to the following description in consideration of the accompanying drawings, in which like reference numbers indicate like features.

[17] Figure 1 is a perspective view of an embodiment of an oral care implement such as a toothbrush in accordance with this invention.

[18] Figure 2 is a side elevational view, in partial section, of the toothbrush shown in Figure 1.

[19] Figure 3 is a top, plan view of the toothbrush shown in Figures 1 and 2.

[20] Figure 4 is a side elevational view similar to Figure 2 shown partially broken away.

[21] Figure 5 is a side elevational view showing a subassembly of the bristle containing portion of a brush head in accordance with an aspect of the invention.

[22] Figure 6 is a side elevational view, in partial section, showing the subassembly of Figure 5 incorporated in a completed toothbrush according to an embodiment of the invention.

[23] Figure 7 is a perspective view of a head portion of an oral care implement in accordance with an embodiment of the invention.

[24] Figure 8 is a side view of the head portion shown in Figure 7.

[25] Figure 9 is a top view of the head portion shown in Figures 7 and 8.

[26] Figure 10 is a side view of a head portion of an oral care implement in accordance with an embodiment of the invention.

[27] Figure 11 is a top view of the head portion shown in Figure 10.

[28] Figure 12 is a top view of a soft tissue cleaner side of an oral care implement in accordance with a further embodiment of the invention.

[29] Figure 13 is a partial perspective view of the oral care implement of Figure 12 without tooth cleaning elements.

[30] Figure 14 is a top view of an oral care implement in accordance with a further embodiment of the invention.

[31] Figure 15 is a partial perspective view of the oral care implement of Figure 14 without tooth cleaning elements.

[32] Figure 16 is a partial perspective view of an oral care implement according to a further embodiment of the invention without tooth cleaning elements.

[33] Figure 17 is a top view of an oral care implement in accordance with a further embodiment of the invention.

[34] Figure 18 is a partial perspective view of the oral care implement of Figure 17 without tooth cleaning elements.

[35] Figure 19 is partial perspective view of an oral care implement according to an embodiment of the invention.

[36] Figure 20 is a side elevational view of the oral care implement of Figure 19.

[37] Figure 21 is a side elevational view of a further embodiment of an oral care implement.

[38] Figure 22A is a side elevational view of another embodiment of an oral care implement.

[39] Figure 22B shows the oral care implement of Figure 22A while engaging a tooth.

[40] Figure 23A is a top view of an oral care implement according to another embodiment of the invention.

[41] Figure 23B is a side elevational view of the oral care implement of Figure 23A.

[42] Figure 24A is a top view of an oral care implement according to another embodiment of the invention.

[43] Figure 24B is a side elevational view of the oral care implement of Figure 24A.

[44] Figure 25A is a top view of a head of an oral care implement according to another embodiment of the invention.

[45] Figure 25B is a side elevational view of the oral care implement of Figure 25A.

[46] Figure 25C is a top view of a head of an oral care implement according to another embodiment of the invention.

[47] Figure 25D is a side elevational view of the oral care implement of Figure 25C.

[48] Figure 25E is a top view of a head of an oral care implement according to another embodiment of the invention.

[49] Figure 26 is a bottom perspective view of a head of an oral care implement according to another embodiment of the invention.

[50] Figure 27 is a cross-sectional view of the oral care implement of Figure 26.

[51] Figure 28 is a side elevational view of the oral care implement according to another embodiment of the invention.

[52] Figure 29 is a bottom perspective view of a head of an oral care implement according to another embodiment of the invention.

DETAILED DESCRIPTION OF THE PREFERRED EMBODIMENTS

[53] The following embodiments describe aspects of the invention in the form of various oral care implement configurations that provide a variety of features and functions. Although these aspects are disclosed in the context of particular exemplary embodiments, the invention provides an oral care implement that includes one or more of the features described herein. The oral care implement may include a first feature described in one example configuration herein, as well as a second feature described in another example configuration herein.

[54] In other words, the invention contemplates mixing and matching features from the disclosed embodiments in various combinations into a single oral care implement. The present invention thus makes it possible to select a combination of cleaning element configurations, tissue cleaner configurations, handle features, gripping features, mechanical driving features, materials and orientations, etc. to achieve intended results, and to deliver additional oral health benefits, such as enhanced cleaning, tooth polishing, tooth whitening, tongue cleaning, massaging of gums, etc.

[55] The term "cleaning elements" is intended to be used in a generic sense which could include elements for cleaning, treating, polishing, whitening, scraping, scrubbing, etc. Cleaning elements may include, but are not limited to, nylon or fiber bristles, massage elements, and elastomeric fingers or walls arranged in a circular cross-sectional shape or any type of desired shape including straight portions or sinusoidal portions. In the form of bristles, the cleaning elements may be secured to a flexible membrane or web via in-molded technology, mounting the tuft blocks or sections by extending them through suitable openings in the flexible membrane, or other mechanisms.

[56] A variety of oral care implement configurations are disclosed herein. One configuration is an oral care implement having multiple groupings of cleaning elements that are uniquely mounted to the head of the oral care implement to facilitate flexible orientation of some groupings relative to the teeth and gums being cleaned. For example, groupings of the head may cooperate to "wrap around" individual teeth resulting in deeper penetration of cleaning/treating elements between teeth. Such configurations can provide effective overall cleaning, for example, by independent movement of groups of cleaning elements relative to the head and each other. This configuration and others are described below.

[57] Figures 1-4 illustrate a toothbrush 610 in accordance with one embodiment of this invention. As shown therein toothbrush 610 includes an elongated handle 612 with a head 614 connected to and extending from the handle. The head 614 is divided into a plurality of separate cleaning areas which are spaced from each other. As illustrated the cleaning areas include a base 616 located at the distal end of the head 614 and projecting outwardly from the main body portion 930 (Figure 4) of the head. Base 616 includes at least one and preferably a plurality of cleaning elements 618. Head 614 further includes a base or supporting member 620 at the proximal end of head 614. Cleaning elements 618 also extend outwardly from base 620.

[58] Mounted between the cleaning areas that incorporate bases 616 and 620 are a pair of pods 622, 624. Each pod is provided with at least one and preferably a plurality of cleaning elements. As later described the pods 622, 624 have greater degrees of freedom than do the bases 616, 620. In a preferred practice of the invention the pods 622, 624 are resilient members so that the pod cleaning elements add a motion range beyond the cleaning elements 618 which are generally static or non-movable. Because the various cleaning elements are separated from each other such as by channels 728, which extend completely across head 614 in a transverse direction, and because of the elastic nature of pods 622, 624, the cleaning elements 626 may be capable of 360 degrees rotation about the vertical axis of each individual pod. The angle of the bend may be dictated by the ability of the material to bend.

[59] Toothbrush 610 thus provides a head 614 wherein the front (distal end) and the back (proximal end) areas are in a relatively fixed position and wherein the cleaning/treating elements, such as bristle strands, 618 do not have any extra degree of motion. The middle

portion of head 614, however, has two areas of cleaning elements 626, which are capable of 360 degree rotation.

[60] As shown in Figure 4, the head 614 includes a main body portion 930 which supports the bases and pods. Body portion 930 and bases 616 and 620 are preferably made from conventional hard plastic materials, such as polypropylene for example, commonly used in the making of toothbrush handles and heads. Pods 622, 624, however, are made so as to be resilient. In a preferred practice of this invention, the resiliency of pods 622, 624 is achieved by providing a thin diameter beam 932 which extends from the main body portion 930 of the head of the toothbrush. Beam 932 is joined into the bottom of a thin pad or plate 934 which provides a support area onto which the cleaning elements 626 are affixed. The manner of mounting the cleaning elements 626 to the support pads 934 can be achieved utilizing various cleaning elements, such as bristles and other cleaning materials, in known attachment methods.

[61] The desired flexibility or resiliency of the pods 622, 624 is enhanced by enclosing the thin beams 932 in elastic material 936 during a multi-injection molding process. The elastic material 936 is resilient such that the beams 932 to their original form or initial position. This return action creates an active motion in the opposite direction of the beam bend which aids in the cleaning of teeth by introducing extra brushing strokes.

[62] As best shown in Figures 1, 2 and 4 the pods 622, 624 include a widened portion disposed toward the body 930. The support pads 934 are also widened. Each pod has a narrow or reduced diameter central portion 938 longitudinally intermediate the length of each pod. Thus, each pod is of generally mushroom shape.

[63] Beam 932 could be of any suitable shape such as having a cross-section which is circular, square or any other geometric shape that provides a thin dimension or thin diameter to the beam to facilitate the bendability of the beam. The elastomer 936 may be considered as a continuous layer of any suitable thickness which covers the entire central area of head 614 as illustrated so that both pods 622, 624 are incorporated as part of the same elastic material. The portion of the head 614 which includes pods 622, 624 may be formed as a separate subassembly similar to the subassembly later described with respect to Figures 5 and 6.

[64] Although the invention could be practiced with a single base and a single pod and could be practiced with the base having some, but a lesser degree of flexibility than the pod, the invention is preferably practiced wherein the base is generally static or non-movable. In addition, the invention is preferably practiced where there are a plurality of such bases and a plurality of pods. The drawings illustrate a configuration of the invention where there are a total of four separate cleaning areas with the pods being located in the central portion of head 614. The invention may be practiced in a configuration in which the cleaning elements comprise a plurality of bristles or strands on each base and each pod.

[65] As illustrated in Figures 3 and 4 each base 616 and 620 and each pod 622 and 624 may have a generally oval outer surface. The bases and pods are longitudinally aligned, but spaced from each other by the depressions or open areas which form the channels 728. As also illustrated in Figure 3 the pods may have a larger outer surface or cleaning element carrying surface than do the bases.

[66] As shown in Figure 2 the terminal surfaces of the cleaning elements 618 and 626 are tapered so that the terminal surfaces of the cleaning elements 618 taper outwardly in a direction toward the center of head 614 while the terminal surfaces of cleaning elements 626 taper outwardly in a direction away from the center of head 614. Thus, the highest points of each set of cleaning elements 618 and its adjacent set of cleaning elements 626 are generally disposed toward each other for each pair of base and pod 616, 622 and 620, 624.

[67] Any suitable form of cleaning elements may be used as the cleaning elements 618 and 626 in the broad practice of this invention. The term "cleaning elements" is intended to be used in a generic sense as described above. Using different cleaning materials as cleaning elements of the toothbrushes may yield different effects. In an attempt to provide better stain removal, a rubber-like material or elastomer can be used in combination with conventional bristles or used by itself to "brighten/whiten" the teeth.

[68] It is to be understood that the specific illustration of the cleaning elements is merely for exemplary purposes. The invention can be practiced with various combinations of the same or different cleaning element configurations (such as stapled, anchor-free tufted (AFT) bristles or in-molded technology (IMT) bristles, etc.) and/or with the same bristle or cleaning elements

materials (such as nylon bristles, spiral bristles, rubber bristles, etc.) Similarly, while Figure 2 illustrates the cleaning elements to be generally perpendicular to the outer surface of head 614, some or all of the cleaning elements may be angled at various angles with respect to the outer surface of head 614. It is thereby possible to select the combination of cleaning element configurations, materials and orientations to achieve specific intended results to deliver additional oral health benefits, like enhanced cleaning tooth polishing, tooth whitening and/or massaging of the gums.

[69] Figures 5-6 illustrate a further embodiment of this invention. The toothbrush 1110A has the ability to provide flexible support for the bristles 1026A, 1126A in designated areas. The flexibility is provided by designing the tuft holding areas 1034A, 1134A as plates, which in combination with the stems 1038A, 1138A form pods of mushroom shape. The mushroom stem 1038A, 1138A is made flexible to allow the plate 1034A, 1134A populated with bristles or cleaning elements 1026A, 1126A to move in different directions while brushing, as described with respect to the flexible pods of Figures 1-4.

[70] Figures 5-6 show the toothbrush 1110A and in particular the cleaning element or bristle carrying portion 1023, 1123 of the head 1114A. As shown in Figure 5, the bristle or cleaning element carrying portion 1023 forms an initial subassembly. This subassembly is made by introducing the cleaning elements 1026A into the mold cavity into which a plastic material is injected. As the material injected cools off it permanently traps the bristles or cleaning elements 1026A to form a brush or subassembly 1023.

[71] To achieve a functional flexibility and proper tuft retention the portion of the bristle holding part or subassembly 1023 which comprises the plates 1034A, stems 1038A and interconnecting support 1025 is preferably a blend of polypropylene (PP) and soft TPE. Once the PP/TPE blend is combined with the bristles 1026A the subassembly 1023 is formed. The subassembly 1023 is then overmolded with an entire toothbrush handle 1112A and head 1114A during a second injection cycle to form the completed toothbrush 1110A shown in Figure 6. If desired or required the entire handle 1112A and head 1114A absent the subassembly 1123 could be made first and the subassembly or bristle retaining portion 1123 made second. While an IMT process has been described, the subassembly could also be formed using an AFT process,

wherein the cleaning elements are fused together and then captured within the plates, for example.

[72] It is to be understood that the invention described in Figures 5-6 could be practiced where all portions of the head 1114A include the flexible mushroom sections without having less flexible base portions such as bases 616 and 620 of Figures 1-4. Similarly, the subassembly two shot techniques of Figures 5-6 could be utilized in the embodiment of Figures 1-4 for forming the two or more central pods as a single subassembly initially made separate from the remainder of the head 1114A. The final toothbrush would be made in a second injection molding process wherein the subassembly having interconnected pods 622, 624 would be molded to the handle 612 and head 614 made of more rigid material.

[73] As noted, Figure 2 illustrates the terminal surfaces of the cleaning elements 618 and 626 to be tapered in an up and down or zigzag manner. Figures 5-6 show an alternative taper wherein the terminal surfaces form a smooth, gentle, concave shape. If desired, other shapes may be used such as a planar shape for the terminal surfaces or a convex shape as well as the zigzag or up and down shape shown in Figure 2. Similarly, the terminal ends of the cleaning elements in the Figures 1-4 embodiment, as well as those of Figures 5-6, could have the various shapes such as zigzag, convex, concave or planar.

[74] Figures 7-25E show additional embodiments of the invention that further illustrate the combinability of various aspects, features and functions disclosed herein into single oral care implement configurations. Figures 7-25E disclose oral care implement configurations that provide a tooth cleaner having separate groups of cleaning elements, which may each be mounted on a fixed base or a flexible pod, and which may provide a soft tissue cleaner in addition to the tooth cleaner. The configurations may be powered or manual devices, and the handles may include gripping features. As such, the oral care implements disclosed in Figures 7-25E generally include the aspects discussed along with Figures 1-6 pertaining to groups of cleaning elements that may include flexible pods. It is understood that other features may be used along with these configurations, such as mechanical drive features discussed in co-pending applications 11/122,224 and 10/768,363 (i.e., the heads of the various embodiments described

herein could be vibrating heads) and tooth cleaning features discussed throughout the specification.

[75] Figures 7-9 illustrate an oral care implement 9910, such as a toothbrush, in accordance with another embodiment of the invention. As shown therein, toothbrush 9910 includes a head 9914 and a handle 8103. Handle 8103 may be formed in accordance with the teachings of U.S. Application 10/902,257, filed July 30, 2004, incorporated by reference herein, although other handle configurations may be used, such as handle 612, 1112A shown in Figures 1-6. Head 9914 is generally the same as head 614 discussed along with Figures 1-6, with the exception of cleaning elements 9918 and the contoured surface 9940 disposed on an opposite side of the head from the cleaning elements. Thus, head 9914 generally includes bases 616 and 620 that respectively support cleaning elements 9942 and 9944 in a substantially static configuration. Head 9914 also includes pods 622 and 624 disposed between the bases for respectively supporting cleaning elements 9946 and 9948. As discussed along with Figures 1-6, pods 622 and 624 can provide flexible mounts for cleaning elements 9946 and 9948 attached thereto, and may permit rotation and/or oscillation of the cleaning elements 9946 and 9948.

[76] Figure 7 shows a contoured surface 9940 disposed on an opposite side of the head from the cleaning elements. Contoured surface 9940 includes hills 9950 and valleys 9952 to provide a rolling or undulating surface on a rear face of the head. Surface 9940 may be relatively smooth for use with massaging oral tissues and, as illustrated in Figures 10 and 12-18, the surface may include soft tissue cleaning elements for engaging soft oral tissues and provide cleaning benefits thereto.

[77] Figure 9 is top view of head 9914, which shows a configuration of tooth cleaning elements 9918 for use with head 9914. Cleaning elements 9918 may be formed of elastomeric wall members, elongate bristle tufts, or other types of cleaning elements, which are independently flexible. In this way, the cleaning elements are able to provide a limited and controlled flow of the dentifrice, as well as maintain sufficient flexibility to provide improved cleaning of a user's teeth and stimulation of the user's gums via the cleaning elements.

[78] Cleaning elements 9918 are oriented for engaging surfaces to be cleaned in a generally intended application direction A (see Figure 8), which is generally perpendicular to the face of

head 9914. Cleaning elements 9918, however, include a mixture of cleaning elements that are aligned with (non-angled) and oblique to direction A (angled). The arrangement of angled and non-angled cleaning elements provides effective engagement and cleaning of oral surfaces, which is further enhanced by the movable pods configuration. The cleaning elements 9946 and 9948 mounted on pods 622 and 624 are adapted to engage a user's teeth, gums and other surfaces in a various ways that take advantage of their flexible support configuration. As such, cleaning elements 9946 and 9948 include forward elements 9950 angled toward the tip end of the head, and rearward elements 9952 angled toward the handle. As shown, the forward and rearward elements 9950, 9952 are preferably placed on the forward and rearward sides of their respective pods, and more preferably, are placed in the corner regions of the pods. Such a location and orientation increases the likelihood that elements 9950 and 9952 will initially engage a surface to be cleaned prior to other cleaning elements on the respective pod, which encourages the respective pod to flex as the remaining cleaning elements thereon are engaging the surface.

[79] For instance, as oral care implement 9910 is moved forward such that head 9914 leads the toothbrush, forward elements 9950 will initially engage surfaces to be cleaned prior to rearward elements 9952 or other cleaning elements disposed between elements 9950 and 9952. The forward angle of elements 9950 will encourage pods 622 and 624 to bend rearward when the forward elements contact a surface to be cleaned while the toothbrush is moving forward. The rearward bending of the pods, and their action of springing forward in response to the bending, enhances the cleaning effectiveness of the cleaning elements 9946 and 9948 disposed on the pods. The angled configuration of elements 9950 and 9952 improves the bending of the pods in comparison with alternate embodiments wherein the cleaning elements are disposed perpendicular to the toothbrush face 9954 and are angled neither forward nor rearward.

[80] Cleaning elements 9946 and 9948 of the pods also include non-angled cleaning elements 9954, which are beneficial for penetrating surfaces to be cleaned. In addition, cleaning elements 9946 and 9948 include a pair of bent, upstanding walls 9956 in a central portion of the pods. Such walls could be formed as a densely packed bristle tuft by an IMT or AFT process, or such walls could include elastomeric elements. Other configurations are contemplated. Each one of the walls in the pair 9956 has a concave side opposing the concave side of the other wall in the pair. The bent configuration and opposed convex sides of upstanding walls 9956 improve

retention of dentifrice therebetween during use of the oral care implement. In addition, the bent configuration provides a pair of rigid walls, which, in their central location of the pod, supports the pod to prevent overflexing of the cleaning elements 9946, 9948.

[81] Cleaning elements 9942 and 9944 disposed on static bases 616 and 620 are configured to cooperate with cleaning elements 9946 and 9948 on the movable pods, as well as to effectively clean oral surfaces. The bases each include a bristle 9960, a series of upstanding walls 9962, and angled cleaning elements 9964, 9966. Bristle 9960 is generally a non-angled column that effectively penetrates gaps and recesses between oral structures (e.g., teeth).

[82] The series of upstanding walls 9962 are arranged to generally form a concave wall directed toward the remaining cleaning elements 9918. Thus, the concave wall 9962 of the front base 616 has its concave side directed rearward toward the handle, and the concave wall on the rear base 620 has its concave side directed forward toward the remainder of bristles 9918. In such a configuration, the opposing concave walls work in concert to retain dentifrice within the field of bristles 9918 via their concave shape that cups the dentifrice, as well as via small gaps between the upstanding walls that form the concave walls, which reduce the flow of dentifrice therebetween. In addition, the upstanding walls forming the concave walls are non-angled cleaning elements that provide support to the head 9914 during use and resist overflexing of the cleaning elements when excessive downward force is applied by the user.

[83] Angled cleaning elements 9962 and 9964 are angled toward the movable pods 622 and 624 to cooperate with cleaning elements 9946 and 9948 attached thereto for effectively cleaning oral surfaces. As such, rear base 620 includes forward angled elements 9964, and front base 616 includes rearward angled elements 9966. Angled cleaning elements 9962 and 9964 are disposed close to one another inward of a respective pair of angled cleaning elements 9950 and 9952 of the movable pods. Thus, as the pods flex back and forth, angled cleaning elements 9962 and 9964 interpose between corresponding angled cleaning elements 9964 and 9966. This provides a scissor-like action that enhances cleaning effectiveness and avoids interference between opposing cleaning elements 9964, 9966 and 9962, 9964 that may limit movement of the pods.

[84] The cleaning elements described in connection with the embodiment of Figures 7-9, as well as the embodiments to follow, are preferably formed using an AFT technique as is known in

the art. This technique facilitates the arrangement of cleaning element constructions that depart from the traditional stapled perpendicular tuft. With AFT technology, the anchored ends of the cleaning elements are melted together to form a block of cleaning elements, that can then be arranged on a head plate with various dimensions, angles and orientations. Thus, the blocks of cleaning elements are generally captured within the pod structures, not embedded in a supporting medium.

[85] Referring now to Figures 10-13, an oral care implement 10210 is shown in accordance with a further embodiment of the invention. As shown therein, oral care implement 10210 includes a handle 8103, a head 10214 having cleaning elements 10218 attached thereto on a first side of the head, and a soft tissue cleaner 10280 disposed on a second side of the head that is opposite to the first side. Oral care implement 10210 generally includes the aspects and features of oral care implement 9910, except as pertaining to the configuration of cleaning elements and the soft tissue cleaning features. Cleaning elements 10218 primarily include upstanding walls, which may include an elastomeric element, or may be formed as a densely packed bristle tuft by an IMT or AFT process. Other configurations are contemplated. The upstanding walls provide beneficial wiping and polishing of teeth, in addition to cleaning benefits. Cleaning elements 10218 also include a central columnar cleaning element 10270, which may be a bristle, for penetrating oral surfaces. As shown in Figure 10, each central cleaning element 10270 extends beyond other cleaning elements proximate thereto on the same pod. In addition, central cleaning element has a pointed tip. As such, central cleaning element 10270 effectively penetrates and engages oral surfaces and gaps between surfaces.

[86] Similar to the configuration of Figures 4 and 7, and as shown in Figure 11, the tips or terminal ends of cleaning elements 10218 are tapered such that the pods are respectively encouraged toward their adjacent static base while engaging surfaces to be cleaned. Thus, during use, cleaning elements 9948 are generally biased toward engagement with cleaning elements 9944 on rear base 620, and cleaning elements 9946 are generally biased toward engagement with cleaning elements 9942 on front base 616. This bias can work along with movement of the pods that is imparted via engagement of angled cleaning elements with cleaning surfaces when the device is being moved. Increasing movement and the flexing of bases 622 and 624 further enhances the cleaning effectiveness of the oral care implement.

[87] The soft tissue cleaner 10280 includes a plurality of projections 10281 extending from a face 10284 on a second side of head 10214, which is generally opposite from the direction in which tooth cleaning elements 10218 extend. Soft tissue cleaner 10280 is disposed on a contoured surface, such as contoured surface 9940 shown in Figure 7, which includes hills 9950 and valleys 9952 to provide a rolling or undulating surface on a second face of the head. Projections 10281 may be separately molded and glued to the contoured surface or otherwise attached thereto. In addition, they may be integrally formed with the head 10214. The projections could each be made from a material different from other projections and/or different from other parts. Soft materials, such as a TPE or the like, can be fixed to head 10214 to form the projections. However, a harder material or virtually any known material used to make oral care implements may be appropriate for the projections.

[88] Projections 10281 include a plurality of nubs 10282, which extend from contoured surface 9940 to engage the soft tissue in a user's mouth. The projections 10281 could have a variety of shapes, patterns, cross-sections, configurations, etc., and the soft tissue cleaner could have a variety of configurations for the projections.

[89] As shown in Figure 13, nubs 10282 generally cover rear face 10284 in a cleaner field 10288, which extends from a region opposite the rear base 620 at a lower portion of the head to a region opposite the front base 616 at a tip portion of the head. The nubs are dispersed in a substantially continuous pattern over the cleaner field. The cleaner field includes hills 10290 proximate edge portions of face 10284, and valleys 10292 disposed between the hills and at a central portion of the face. The configuration of hills and valleys enhances the effectiveness of the soft tissue cleaner by concentrating the applied force at the hill portions during initial contact with a user's soft tissue, which can increase penetration into the soft tissue versus a relatively flat configuration. As the user applies additional force, the valleys contact the soft tissue to aid in cleaning the soft tissues. If excessive force is applied, the valleys help to limit excessive penetration. When the nubs in the valley regions engage the soft tissue, they provide the added benefit of dislodging debris that is loosened by the deeper penetration of nubs on the hills. Thus, projections on the hills and valleys work in concert to initially loosen and then dislodge debris in a user's soft tissue.

[90] Figures 14 and 15 illustrate another embodiment 10610 of an oral care implement according to the invention. Oral care implement 10610 generally includes the same aspects and features of oral care implement 10210, except with respect to the configuration of projections on the soft tissue cleaner 10680. Rather than having nubs across the cleaner field, soft tissue cleaner 10680 only includes nubs 10282 on the hills 10288. Instead, multiple ridges 10294 are disposed in some of the valley regions 10290 including a central portion of face 10284. The ridges can be made from the same or a different material than the nubs. For instance, the nubs and ridges may be made of the same type of elastomer; however, the elastomer for the ridges may be more rigid than that for the nubs.

[91] Ridges 10294 have variable lengths that provide variable levels of soft tissue engagement during use. As such, longer and shorter ridges can work in concert to loosen and dislodge debris as the different lengths of ridges successively engage portions of soft tissue. Ridges 10294 taper from a wide base region disposed proximate the face 10284, to a narrower tip 10696. Thus, increasing levels of soft tissue engagement are provided depending on the amount of user force applied.

[92] Figure 16 illustrates another embodiment 10810 of an oral care implement according to the invention. Oral care implement 10810 generally includes the same aspect and features of oral care implement 10610, except with respect to the configuration of projections on the soft tissue cleaner 10880. Soft tissue cleaner 10880 differs from soft tissue cleaner 10680 in that it does not include ridges 10294. Thus, soft tissue cleaner includes nubs 10282 that are only located on hills 10288 along the side portions of face 10284. As such, gentle cleaning is provided via the nubs located on the hills. The gentle cleaning is beneficial for simultaneous functionality of the oral care implement, such as when a user cleans his teeth while simultaneously engaging soft tissues inside his cheek via soft tissue cleaner 10880. The gentle engagement can provide pleasant sensory stimulation along with gentle cleaning of the soft tissues.

[93] Figures 17 and 18 illustrate another embodiment 10910 of an oral care implement according to the invention. Oral care implement 10910 generally includes the same aspects and features of oral care implement 10610, except with respect to the configuration of projections on

the soft tissue cleaner 10980. Soft tissue cleaner 10980 differs from soft tissue cleaner 10680 in that ridges 10994 are not provided in the central portion of face 10284, but are provided in valleys 10290 disposed between adjacent pairs of hills 10288. In addition, ridges 10994 are generally smaller than ridges 10294. As such, gentle cleaning is provided, which, similar to oral care implement 10810, can be beneficial during simultaneous functionality of the device.

[94] Referring now to Figures 19-20 an oral care implement 12000 is shown in accordance with a further embodiment of the invention. As shown therein, oral care implement 12000 includes a handle 8103, a head 12002 having a frame 12004, bases or pods 12010, 12020, 12032 and 12034 on a front side of the head, cleaning elements 12218 extending from the pods, and a soft tissue cleaner 12280 disposed on a rear side of the head that is opposite to the front side. Oral care implement 12000 generally includes the aspects and features of oral care implement 10210 shown in Figures 10-13, except as discussed hereafter. The soft tissue cleaner 12280 is generally the same as soft tissue cleaner 10280. However, various soft tissue cleaner configurations may be used, such as, for example, the soft tissue cleaners of Figures 14-18.

[95] Oral care implement 12000 shown in Figures 19 and 20 is illustrated as having four pods: a proximal pod 12010, a distal pod 12020 and two central pods 12032 and 12034. The proximal and distal pods extend from frame 12004, which is on a rear portion of the head. The embodiment shown in Figures 19 and 20 differs from the embodiments shown in Figures 1-18 in that the central pods 12032 and 12034 are not connected directly to the rear, frame portion of head 12002, but rather are suspended between the proximal pod 12010 and the distal pod 12020. The proximal pod and the distal pod are attached to the frame, whereas the central pods are suspended over the frame. As such, the central pods are spaced from the frame such that a gap 12050 is disposed therebetween.

[96] Central pods 12032 and 12034 are suspended via bridge supports 12060, which may include a pair of substantially parallel supports 12067 separated by a gap 12065. A first bridge support extends longitudinally between the proximal pod 12010 and central pod 12034, and a second pair of bridge supports extends longitudinally between distal pod 12020 and central pod 12034. In addition, a bridge support extends longitudinally between central pods 12032 and 12034. Thus each central pod is supported by a pair of opposite bridge supports.

[97] While the illustrated embodiment shows pairs of supports 12067 on each side of each central pod, other configurations are contemplated. For example, instead of a pair of supports 12067, a single bridge element may be disposed between the proximal or distal pod and the adjacent central pod, and between the two central pods. Such a single bridge could be wider than each of the individual pair of supports 12067 such that the width of the single bridge support generally equals the width of the pair of supports plus gap 12065 therebetween.

[98] The central pods 12032 and 12034 generally have greater degrees of freedom than do the proximal and distal pods. In one configuration, bridge supports 12060 and 12070 are substantially rigid. Even so, the suspension arrangement can provide a moderate amount of flexibility to the central pods. In a preferred, more flexible configuration, bridge supports 12060 and 12070 are flexible features that permit the cleaning elements extending from the central pods 12032 and 12034 to have a much larger range of motion than the cleaning elements extending from the proximal and distal pods 12010 and 12020, respectively, which are generally static or non-movable. The flexible bridge supports may be formed from a resilient material, such as a thermoplastic elastomer. Other rubber-like materials may be used, such as other thermoplastics, or a thermoplastic urethane, or a plastomer, or any combination thereof.

[99] In a flexible configuration, bridge supports 12060 and 12070 are resilient and allow the central pods to twist about their support axis and/or move toward frame 12004 when downward force is applied to the central pods during use of the implement. Further, the elastic nature of the bridge supports may permit the central pods to return to their original form or initial position when the force is decreased. In addition, when the oral care implement is moved in a longitudinal direction parallel to the handle 8103, the central pods can deflect longitudinally as they engage a surface to be cleaned. The deflection of the central pods in the longitudinal direction may also be due to the elastic nature of the support bridges 12060 and 12070. Such return action can create an active motion in the opposite direction of the direction of movement, which aids in the cleaning of teeth by introducing extra brushing strokes.

[100] The distance between the proximal pod 12010 and the distal pod 12020 may be greater than the width of the each of the central pods 12032 and 12034, and in the illustrated embodiment of Figure 19 is approximately twice the width of one of the central pods. Further, in

the illustrated embodiment, the central pods 12032 and 12034 are suspended away from the frame a distance slightly less than the thickness of the central pods 12032 and 12034. The length of the support bridges 12060 and 12070 may be significantly less than the length of the central pods 12032 and 12034, and, in the configuration shown in Figures 19 and 20, is approximately 1/5 the length of the central pods. As a result, with two central pods of the configuration shown in Figures 19 and 20, the support bridges 12060 and 12070 span less than 25% of the total distance between the proximal and distal pods 12010 and 12020, respectively.

[101] In addition, the configuration shown in Figures 19 and 20 includes a unitary assembly 12500 (reference number not shown) that forms a top portion of proximal pod 12010, the top of distal pod 12020, bridge supports 12060 and 12070 and central pods 12032 and 12034. The unitary assembly 12500 may be made from an elastomeric material, such as a soft thermoplastic elastomer (TPE). Again, other rubber-like materials may be used, such as other thermoplastics, or a thermoplastic urethane, or a plastomer, or any combination thereof. The top portions 12033 and 12035 of the proximal and distal pods can be attached to protrusions (not shown) extending from the underlying head 12002, thereby providing sufficient support and strength to the proximal and distal pods 12032 and 12034. The top portions may also be formed as unitary features along with the frame of the head, such as from a unitary plastic mold. When formed as differentiated features, the proximal and distal pods could be formed from the same or different materials than the frame, the bridge supports and/or the central pods. For instance, the bridge supports and central pods could be made from a first thermoplastic material, and the proximal and distal pods could be formed separately from a second thermoplastic material, such as polypropylene. In such a configuration, the bridge supports and the central pods could be made as a unitary construction that is welded or adhered to the proximal and distal pods. Further, the bridge supports, the central pods, and the top portions of the proximal and distal pods could be formed as a unitary member that is attached to the frame.

[102] As discussed with regard to the embodiment shown in Figures 7 and 8, the cleaning elements 12218 mounted on the central pods can be adapted to engage a user's teeth, gums and other surfaces in a various ways that take advantage of their flexible support configuration. For instance, as shown in Figure 19, the cleaning elements provided on the central pods can include forward elements 12090 angled toward the tip end of the head, and rearward elements 12092

angled toward the handle end. The location and orientation of these forward and rearward elements can increase the likelihood such elements will initially engage a surface to be cleaned prior to other cleaning elements on the respective pod, thereby encouraging the respective pod to flex as the remaining cleaning elements thereon engage the surface.

[103] As further shown in Figure 19, cleaning elements 12218 may include upstanding walls 12094, which may be elastomeric or bristle-based as discussed above. The upstanding walls can provide beneficial wiping and polishing of teeth in addition to cleaning benefits. Cleaning elements 12218 may further include a central columnar cleaning element 12270, which may include one or more bristles for penetrating oral surfaces. The columnar cleaning elements may extend beyond other cleaning elements proximate thereto on the same pod, and they may have a generally pointed tip. As such, central cleaning element 12270 can effectively penetrate and engage oral surfaces and gaps between surfaces.

[104] The tips or terminal ends of cleaning elements 12218 may be tapered such that the suspended pods are respectively encouraged toward their adjacent proximal or distal pod 12020 and 12010, respectively, while engaging surfaces to be cleaned. Thus, during use, cleaning elements extending from central pod 12032 may generally be biased toward engagement with cleaning elements extending from proximal pod 12010, whereas cleaning elements extending from central pod 12034 may generally be biased toward engagement with cleaning elements extending from distal pod 12020. This bias can cooperate with movement of the pods imparted via engagement of angled cleaning elements with cleaning surfaces when the device is being moved. Increasing movement and the flexing of the suspended central pods 12032 and 12034 further enhances the cleaning effectiveness of the oral care implement.

[105] Referring now to Figure 21, a toothbrush 13000 is shown that is similar to the embodiment illustrated in Figures 19 and 20 and generally has the same the aspects and features, except as pertaining to its central pod and the configuration of cleaning elements 13218 and its lack of a soft tissue cleaner. Toothbrush 13000 includes a handle 8103 and a head 13002 having a combination of fixed and suspended cleaning elements. Head 13002 includes a frame 13004, proximal and distal pods 13010 and 13020, and a single central pod 13050 suspended between

the proximal and distal pods. The handle 8103, head 13002 and proximal and distal pods 13010 and 13020 may be formed as a unitary construction from a thermoplastic, such as polypropylene.

[106] Single central pod 13050 has an elastomeric section 13055 disposed in a middle portion of the central pod. The elastomeric section is preferably made from a resilient material, such as a soft thermoplastic elastomer (TPE), while the central pod is preferably made from more rigid material, such as polypropylene. The central pod 13050 is held in place by a molded TPE membrane 13070 that connects with the proximal and distal pods 13010 and 13020 to form bridge supports 13060. The membrane 13070 may form a loop that encompasses the pair of fixed proximal and distal pods 13010 and 13020 and attaches to opposing sides of central pod 13050. Grooves (not shown) in side portions of the proximal and distal pods, as well as the central pod, may receive membrane 13070. In addition, membrane 13070 may be attached to the pods via an adhesive and/or a melt bond.

[107] Membrane 13070 allows the central pod 13050 to move toward frame 13004 when sufficient force is applied during a cleaning operation. When such force is applied to the central pod, opposite halves 13051 and 13053 of the central pod will also flex about the elastomeric section 13055. As a result, the two sets of cleaning elements 13218 extending from either end of the central pod 13050 can rotate toward one another. The central pod 13050 can flex back to its original position when the force on the central pod moving it toward the head 13002 diminishes.

[108] Cleaning elements 13218 extending from central pod 13050 are generally centrally-tapered, which is generally an opposite orientation to the configuration of cleaning elements shown in Figures 10 and 11 and Figures 19 and 20. The central taper encourages cleaning elements 13218 to penetrate interproximal spaces of the user's teeth while applying moderate force to toothbrush 13000 against their teeth. When the user applies more excessive force to the toothbrush, central pod 13050 moves into contact with frame 13004 and causes the central pod to bend about elastomeric section 13055 and further engage the interproximal space to which the cleaning elements are applied.

[109] Referring now to Figures 22A and 22B, a toothbrush 13010 is shown that is similar to the embodiment illustrated in Figure 21 and generally has the same the aspects and features as toothbrush 13000, except as pertaining to its frame. As shown, frame 13007 includes a resilient

hinge element 13080 located in a central portion of the frame and traversing its width. The hinge element may be formed from a TPE or other resilient material that is more flexible than other portions of the frame. The hinge element may also include a reduced thickness region of the frame about which a TPE or other resilient material is disposed. For instance, a proximal portion 13082 of the frame and a distal portion 13084 of the frame may be formed from a relatively rigid material, such as a polypropylene material, and may include a thin neck region (not shown) disposed therebetween. The neck region may permit the proximal and distal portion of the frame to rotate with respect to each other. A resilient material 13081 may surround the neck to dampen rotation about the neck. The resilient material may be adhered to the frame via an adhesive bond, a melt bond or other attachment mechanism, such as a compression fit about the neck.

[110] Hinge element 13080 permits proximal and distal portions 13082 and 13084 respectively of frame 13004 to rotate with respect to one another during use. Thus, head 13010 can generally curl or bend around a surface to be cleaned, such as a user's tooth as illustrated in Figure 22B. In addition, hinge element 13080 can simply improve the overall flexibility of the head for adapting to a variety of cleaning features, orientations of use, and applied forces. For instance, as shown in Figure 22B, hinge element 13080 can permit frame 13007 to flex like a bow. In another example (not shown), hinge element 13080 can permit the tip portion of the head to be flexed rearward, which will encourage central pod 13050 to move away from the frame as the bridge supports are stretched taut.

[111] Referring now to Figures 23A and 23B, an oral care implement 13020 is shown that is similar to the embodiment illustrated in Figure 21 and generally has the same the aspects and features as toothbrush 13000, except as pertaining to its central pod, the arrangement of cleaning elements 13218, and the existence of a soft tissue cleaner 13280 disposed on a rear side of its head that is opposite to the front side. The soft tissue cleaner 13280 is generally the same as soft tissue cleaners 10280 and 12280 of Figures 10-13 and 19-20 respectively. However, various soft tissue cleaner configurations may be used, such as the soft tissue cleaners of Figures 14-18. Toothbrush 13020 includes a central pod 13058 that is substantially unitary and lacks elastomeric section 13055 of toothbrush 13000. Thus, the central pod can provide relatively firm engagement of oral features to be cleaned via the larger rigid central pod, while retaining benefits provided via its suspended configuration. As such, central pod can adapt to the cleaning forces

applied to the head by moving fore, aft, sideways and/or downward with respect to the frame. However, its relatively large, rigid size can provide uniform orientation to a large number of cleaning members 13218 attached thereto.

[112] Cleaning elements 13218 extending from the central pod are similar to the cleaning elements 12218 of toothbrush 12000 and generally include the same configuration, aspects and features as cleaning elements 12218 shown in Figure 19. However, as central pod 13058 is single pod that spans about the same distance as central pods 12032 and 12034 of toothbrush 12000 in Figure 19, central pod 13058 includes additional cleaning elements in its central region. As shown in Figure 23A, a central columnar cleaning element 13096 is located at a central portion of the central pod, which is similar to columnar cleaning elements 12270 of toothbrush 12000. Columnar cleaning element 13096 cooperates with columnar cleaning elements 12270 to effectively penetrate and engage oral surfaces and gaps between surfaces and to transmit downward force to the central pod when excessive cleaning force is applied to the cleaning elements. In addition, several radial cleaning elements 13098 extend from the central columnar cleaning element 13096 in a generally spoke-like configuration at a central region of the central pod. Radial cleaning elements engage features to be cleaned throughout a central portion of the pod, which provide a perimeter structure at side portions of the central pod. The perimeter structure enhances engagement of oral features to be cleaned and can assist with retaining dentifrice within the cleaning elements of the central pod during use.

[113] Referring now to Figures 24A and 24B, a toothbrush 14000 is shown that is similar to the embodiment illustrated in Figure 21 and comprises a handle 8103 and a head 14002 having a combination of fixed and suspended cleaning elements. Head 14002 includes a frame 14004, proximal and distal pods 14010 and 14020 having cleaning elements 14018, and a single central pod 14050 suspended between the proximal and distal pods. The handle 8103, head 14002 and proximal and distal pods 14010 and 14020 may be formed as a unitary construction from a thermoplastic, such as polypropylene. A soft tissue cleaner 14280 is generally the same as soft tissue cleaners 10280 and 12280 of Figures 10-13 and 19-20 respectively. However, various soft tissue cleaner configurations may be used, such as the soft tissue cleaners of Figures 14-18.

[114] Central pod 14050 has an elastomeric section 14055 disposed in a middle portion of the central pod, or more particularly between a pair of pod segments. The elastomeric section is preferably made from a resilient material, such as a soft thermoplastic elastomer (TPE), while the central pod is preferably made from more rigid material, such as polypropylene. The central pod 14050 is held in place by a molded TPE membrane 14070 that connects with the proximal and distal pods 14010 and 14020 to form bridge supports 14060. The membrane 14070 may form a loop that encompasses the pair of fixed proximal and distal pods 14010 and 14020 and attaches to opposing sides of central pod 14050. Grooves (not shown) in side portions of the proximal and distal pods, as well as the central pod, may receive membrane 14070. In addition, membrane 14070 may be attached to the pods via an adhesive and/or a melt bond, for example.

[115] The cleaning elements 14218 on the central pod 14050 are similar to the configuration of the cleaning elements shown in Figures 19 and 20, with the exception of a plurality of central, flexible cleaning elements 14270 extending from the frame 14004 and protruding through one or more openings (not shown) in the central pod 14050. Cleaning element 14270 further comprises massaging and/or polishing elements 14272 on its upper surface. While two cleaning elements 14270 are shown, it will be appreciated that only one, or more than two cleaning elements 14270 may be used as desired. Cleaning element 14270 may be attached to the frame 14004, or extend through the frame 14004 from the soft tissue cleaner 14280 on the opposite side of the head 14002. If the latter, the cleaning element 14270 may be molded simultaneously with the soft tissue cleaner 14280. In either case, a unitary structure defined by the membrane 14070 carrying pods 14010, 14020 and 14050, could be assembled to the base 14004 over the cleaning element(s) 14270. Other methods of construction are contemplated.

[116] Membrane 14070 allows the central pod 14050 and cleaning elements 14218 to move toward frame 14004, guided by the cleaning elements 14270, when sufficient force is applied during a cleaning operation. Such movement provides additional functionality not described before. One such functionality is a tooth polisher in the middle of the head that is surrounded by fixed and movable cleaning elements 14018, 14218 respectively. In addition, the cleaning element 14270 includes massaging and/or polishing elements 14272 that are at a fixed height relative to the head 14004, yet are surrounded by cleaning elements 14218 that recede toward the

head 14004 under brushing pressure, enabling the cleaning elements 14272 to be more efficacious during brushing.

[117] When brushing pressure force is applied to the central pod 14050, segments 14051 and 14053 of the central pod 14050, as well as the cleaning elements 14270, will flex about the elastomeric section 14055. As a result, the cleaning elements 14218 extending from either end of the central pod 14050, as well as the cleaning elements 14270, can rotate toward one another. The central pod 14050 can flex back to its original position when the force on the central pod moving it toward the head 14002 diminishes.

[118] Referring now to Figures 25A-25E, a toothbrush 15000A-C is shown that is similar to the embodiment illustrated in Figures 23A and 23B and comprises a handle 8103 and a head 15002 having a combination of fixed and suspended cleaning elements. Head 15002 includes a frame 15004, proximal and distal pods 15010 and 15020 having cleaning elements 15018, and a central pod 15050 defined by pod segments 15051-15054 (embodiments of Figures 25A through 25D) or pod segments 15055 through 15058 (embodiment of Figure 25E) suspended between the proximal and distal pods. The handle 8103, head 15002 and proximal and distal pods 15010 and 15020 may be formed as a unitary construction from a thermoplastic, such as polypropylene.

[119] The central pod segments 15051-15058 are held in place by a molded TPE membrane 15070 that connects with the proximal and distal pods 15010 and 15020 to form bridge supports 15060. The membrane 15070 may form a loop that encompasses the pair of fixed proximal and distal pods 15010 and 15020 and central pod segments 15051-15058, which segments may be separated by a flexible gap 15062 along the longitudinal axis (embodiment of Figures 25A and 25B) or lateral axis (embodiment of Figures 25C and 25D) of the head 15002. Alternatively, segments 15055-15058 of the embodiment of Figure 25E may be separated by a flexible gap 15062 along both the longitudinal and lateral axes of the head. Grooves (not shown) in the pods may receive membrane 15070. In addition, membrane 15070 may be attached to the pods via an adhesive and/or a melt bond, for example.

[120] The cleaning elements 15218 on the central pod segments are similar to the configuration of the cleaning elements shown in Figures 23A and 23B, with the exception of a central cleaning element 15270 having polishing ridges 15272 along its upper surface that protrudes through an

opening (not shown) in the membrane 15070. Such cleaning element 15270 functions in a similar manner as cleaning element 14270 of Figures 24A and 24B, relative to the membrane 15070 and the central pod segments 15051, 15053 of Figures 25A and 25B. However, because the central pod segments 15051, 15053 are separated along the longitudinal axis of the head 15002 by a gap 15062, such segments 15051, 15053 will tend to rotate away from the protruding cleaning element 15270, or rotate around the cleaning element 15270, under brushing pressure, thereby simulating the movement of a bird's wings, resulting in increased efficacy and interproximal penetration. A similar movement is experienced along the transverse axis with segments 15052, 15054 of Figures 24C and 24D, and an even more extensive movement is experienced along the longitudinal and transverse axes with segments 15055-15058 of Figure 25E. Thus, cleaning element 15270 provides a central pivot around which pod segments 15051-15058 can move.

[121] Cleaning element 15270 may be attached to the frame 15004, or extend through the frame 15004 from a soft tissue cleaner (not shown) on the opposite side of the head 15002. In the latter, the cleaning element 15270 may be molded simultaneously with the soft tissue cleaner. In either case, a unitary structure defined by the membrane 15070 carrying pods 15010, 15020 and central pod 15050 segments 15051-15058, could be assembled to the base 15004 over the cleaning element 15270. Other methods of construction are contemplated.

[122] Referring now to Figures 26 and 27, a toothbrush 16000 comprises a handle 8103 and a head 16002 having a combination of fixed and suspended cleaning elements. Head 16002 includes a frame 16004, proximal and distal pods 16010 and 16020 having cleaning elements 16018, and a central pod 16050 defined by pod segments 16051 and 16053 suspended between the proximal and distal pods. The handle 8103, head 16002 and proximal and distal pods 16010 and 16020 may be formed as a unitary construction from a thermoplastic, such as polypropylene.

[123] The central pod segments 16051 and 16053 may be separated by a bridge 16052 that is preferably flexible and formed from the same material as a molded TPE membrane 16070 that connects with the proximal and distal pods 16010 and 16020 to form bridge supports 16060. The membrane 16070 may form a loop that encompasses the pair of fixed proximal and distal pods 16010 and 16020 and central pod 16050 including segments 16051 and 16053, which

segments may be separated by a flexible gap 16062 along the lateral axis of the head 16002 and/or along the longitudinal axis as shown in other embodiments (see, for example, FIGS. 25A-25E). Grooves (not shown) in the pods may receive membrane 16070. In addition, membrane 16070 may be attached to the pods via an adhesive and/or a melt bond, for example.

[124] Proximal and distal pods 16010 and 16020 may be integral with the head frame 16004, such that the membrane extends around the central portion of such pods, or the pods may terminate at the edge of the membrane 16070 (see the bottom of pod 16050 in FIG. 27) and be attachable to the head frame 16004 by ultrasonic welding, adhesive or the like. Accordingly, membrane 16070 may serve as an outer frame to a plate of cleaning elements included on pods 16010, 16020 and 16050, which plate may be attachable as a single unit to the head frame 16004. Thus, the pods 16010, 16020 and 16050 may be assembled and manipulated as a single unit and attachable to the head frame 16004 as a single unit at the proximal and distal ends of the head frame 16004.

[125] FIG. 27 illustrates the construction of a portion of pod 16050, and more specifically a portion of pod 16051, wherein the bottoms 16019 of cleaning elements 16018 are melted to form a mat 16021, which mat 16021 is captured between a pod housing 16053 and floor 16054. The mat 16021 prevents the cleaning elements 16018 from passing through the tuft holes in the pod housing 16053. The floor 16054, for example, could be adhered or welded to the housing 16053, with the floor 16054 being at least partially surrounded by the membrane 16070. Thus, the cleaning elements 16018 in this embodiment are captured and secured within the pod housing 16053 and floor 16054 in a manner known as anchor-free tufting (AFT), but such cleaning elements are not rigidly and securely fixed to any particular support structure in the manner of a stapled tuft secured within a tuft hole.

[126] The cleaning elements 16018 on the proximal and distal pods 16010 and 16020 may be supported using an AFT process as described above, wherein they would be captured between the respective pod housing and the head frame, or they may be anchored to the pods 16010, 16020 if such pods constitute integral extensions of the head frame 16004. If they are provided using an AFT process, the connection between the pod housing and the head frame would constitute an edge connection, with the pod housing being welded, for example, to the head

frame along the periphery of the pod housing to allow for the mat of melted bristle ends to reside between the pod housing and the head frame.

[127] When brushing with the toothbrush of, for example, FIGS. 22A-22B, that has a toothbrush head that is comprised of several areas with affixed cleaning elements (proximal and distal ends) interconnected with a flexible, central rubber-like field, the central area can bottom and touch the head frame below in an uncontrollable fashion (see FIG. 22B). As a result there may be a clanking noise, a significant "slippage/stretching" of the central portion of the flexible field with an imbedded block(s) of cleaning elements that may cause a damage either to the structure or to the user. By incorporating supports that protrude upwards from the brush head, the flexible field's movements can be controlled with an intent to enable the flexible field to move in a particular fashion relative to the brush head.

[128] FIGS. 26 and 27 illustrate one example of a single, central protrusion 16270 extending from a soft tissue cleaner 16280 on the back of the head 16002 to a depression or notch 16055 provided in the floor 16054 of the tuft block 16050. Such protrusion 16270 is preferably formed or unitarily molded together with the soft tissue cleaner 16280 of a flexible material, although it does not have to be, and provides a pivot point for pod 16050. This enables pod 16050 to move in a controlled fashion relative to the head frame 16004. Depending on the flexibility of the protrusion 16270, pod 16050 may also be capable of normal movement or movement toward the head frame 16004 (again, see FIG. 22B for example). Alternatively, the protrusion 16270 may be rigid and extend from the head frame 16004 to provide a rigid pivot point that resists normal movement of the pod 16050 toward the head frame 16004. Of course, while a single, central protrusion 16270 is illustrated in FIGS. 26 and 27, the number and type of protrusions or supports may vary as shown in, but not limited to, FIG. 28 (multiple supports 17270 and 17271 extending between head frame 17004 and central pod 17050) and FIG. 29 (transverse bar support 18270 extending from the head frame 18004 along the transverse axis of the central pod 18050 of toothbrush 18000, making line contact with the central pod 18050). Each of the embodiments of FIGS. 26-29 enables unique movement of the flexible pod relative to the head frame, with the structure illustrated in FIGS. 26-27 enabling at least a 360 degree pivot, the structure illustrated in FIG. 28 enabling a more restrictive pivoting movement, and the structure illustrated in FIG. 29 enabling a rocking movement over protrusion 18270.

[129] As various changes could be made in the above without departing from the scope of the invention, it is intended that all matter contained in this application, including all mechanisms and/or modes of interaction described above, shall be interpreted as illustrative only and not limiting in any way the scope of the appended claims. Further, as noted above, it is intended that oral care implements according to the invention and associated methods may utilize various combinations of aspects, features and configurations discussed within the application.

What is claimed is:

1. An oral care implement comprising:
a handle;
a head attached to the handle and having a first face;
a proximal fixed pod and a distal fixed pod extending from said first face, said pods further comprising a plurality of cleaning elements; and
at least one central pod disposed between and supported above said first face by said pair of fixed pods by at least one suspension member, said at least one central pod further comprising a plurality of cleaning elements;
wherein at least a portion of said at least one central pod is movable in a direction normal to said first face.
2. The oral care implement of claim 1, wherein said suspension member is made from a resilient material.
3. The oral care implement of claim 2, wherein said resilient material includes a thermoplastic, a thermoplastic elastomer, a thermoplastic urethane, a plastomer, or combinations thereof.
4. The oral care implement of claim 1, wherein said at least one central pod comprises two central pods.
5. The oral care implement of claim 4, wherein said suspension member comprises a first bridge connecting the proximal fixed pod with a first central pod of said two central pods, a second bridge connecting the distal fixed pod and a second central pod of said two central pods, and a third bridge connecting said first and second central pods.
6. The oral care implement of claim 5, wherein said first, second and third bridges each comprises a pair of spaced-apart bridges.

7. The oral care implement of claim 1, wherein said at least one central pod comprises a single pod having at least two groups of cleaning elements extending therefrom.

8. The oral care implement of claim 7, wherein said single pod comprises an elastomeric hinge section that allows said two groups of cleaning elements to move relative to one another.

9. The oral care implement of claim 8, wherein said elastomeric hinge section is oriented substantially transverse to a longitudinal axis of the handle and the head and said two groups of cleaning elements are substantially aligned along said longitudinal axis, said elastomeric section permitting said two groups of cleaning elements to flex toward one another substantially within a plane containing said longitudinal axis.

10. The oral care implement of claim 9, further comprising a flexible hinge section disposed in said head in a direction parallel to said elastomeric hinge section, such that a proximal and distal portion of the head to flex relative to one another.

11. The oral care implement of claim 1, further comprising a hinge section disposed in said head that allows a proximal and distal portion of the head to flex relative to one another.

12. The oral care implement of claim 1, further comprising a soft tissue cleaner on a second face of said head opposite said first face.

13. The oral care implement of claim 1, wherein said pair of fixed pods, said at least one suspension member and said at least one central pod further comprise a unitary structure.

14. The oral care implement of claim 13, wherein said unitary structure is made from an elastomer that envelopes said pair of fixed pods, said at least one suspension member and said at least one central pod.

15. The oral care implement of claim 14, wherein said unitary structure is wider in the transverse direction than each of said pair of fixed pods, said at least one suspension member and said at least one central pod.

16. The oral care implement of claim 14, wherein said unitary structure forms a loop that encompasses said pair of fixed pods and attaches to opposing sides of said central pod.

17. An oral care implement comprising:
a handle;
a head attached to the handle and having a first face;
a proximal fixed pod and a distal fixed pod extending from said first face, said pods further comprising a plurality of cleaning elements;
at least one central pod disposed between and supported above said first face by said pair of fixed pods by at least one suspension member, said at least one central pod further comprising a plurality of cleaning elements; and
at least one protruding element extending from said first face in the direction of said at least one central pod;
wherein at least a portion of said at least one central pod is movable toward said first face.

18. The oral care implement of claim 17, wherein the at least one protruding element extends through said at least one central pod.

19. The oral care implement of claim 17, wherein said at least one protruding element further comprises a plurality of protruding elements.

20. The oral care implement of claim 18, wherein at least a portion of said at least one central pod is movable relative to said at least one protruding element.

21. The oral care implement of claim 18, wherein said at least one protruding element further comprises a protruding cleaning element that is surrounded by the plurality of cleaning elements provided on said at least one central pod.

22. The oral care implement of claim 18, wherein said at least one central pod further comprises two groups of cleaning elements and an elastomeric hinge section that allows said two groups of cleaning elements to move relative to one another.

23. The oral care implement of claim 22, wherein said elastomeric hinge section is oriented substantially transverse to a longitudinal axis of the handle and the head and said two groups of cleaning elements are substantially aligned along said longitudinal axis, said elastomeric section permitting said two groups of cleaning elements to flex toward one another substantially within a plane containing said longitudinal axis.

24. The oral care implement of claim 17, further comprising a soft tissue cleaner on a second face of said head opposite said first face.

25. The oral care implement of claim 24, wherein the at least one protruding element extends from said soft tissue cleaner.

26. The oral care implement of claim 25, wherein the at least one protruding element is unitarily molded with said soft tissue cleaner.

27. The oral care implement of claim 17, wherein said pair of fixed pods, said at least one suspension member and said at least one central pod further comprise a unitary structure.

28. The oral care implement of claim 27, wherein said at least one protruding element is not included in said unitary structure.

29. The oral care implement of claim 17, wherein said pair of fixed pods, said at least one suspension member, said at least one protruding element and said at least one central pod further comprise a unitary structure.

30. The oral care implement of claim 29, wherein said at least one central pod further comprises a plurality of pod segments separated by a hinge aligned along at least one of the longitudinal axis and lateral axis of the head, said at least one protruding element extending through said hinge.

31. The oral care implement of claim 30, wherein said plurality of pod segments further comprises four pod segments arranged around said at least one protruding member, said at least one protruding member defining a pivot point for movement of said pod segments.

32. The oral care implement of claim 17, wherein said at least one protruding element supports said at least one central pod.

33. The oral care implement of claim 32, further comprising a plurality of protruding elements.

34. The oral care implement of claim 32, wherein said at least one protruding element extends laterally across the head and makes line contact with the at least one central pod.

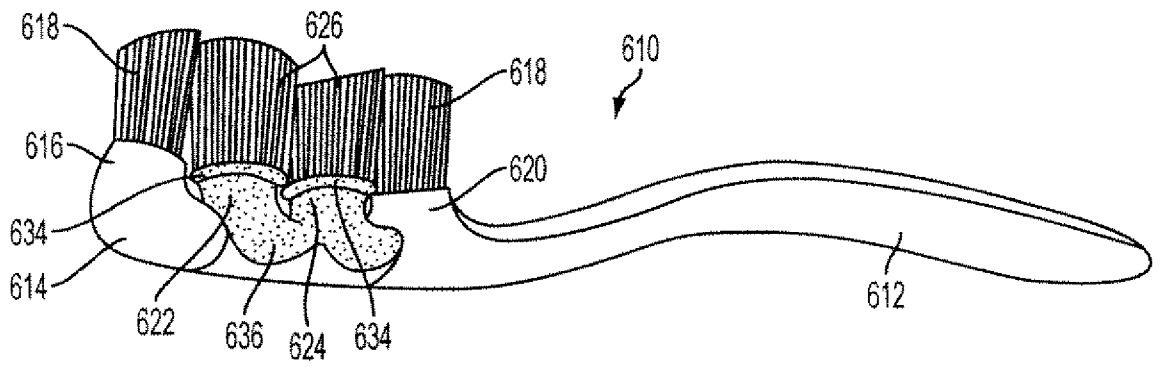

FIG. 1



FIG. 2

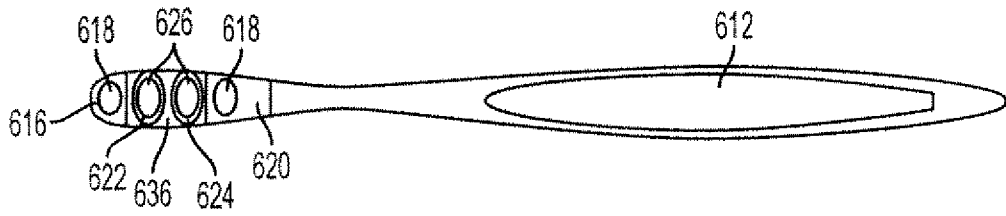

FIG. 3

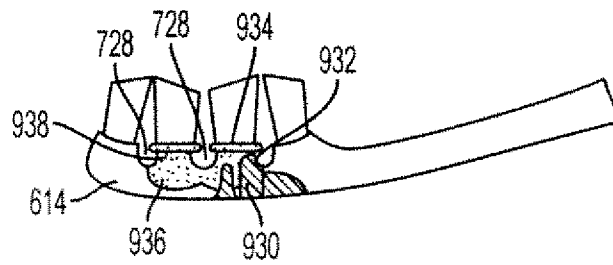

FIG. 4

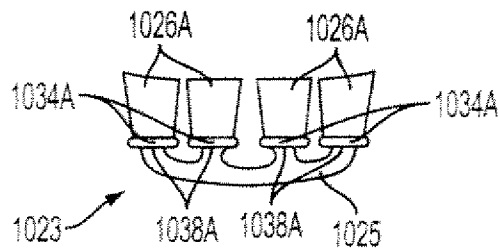

FIG. 5

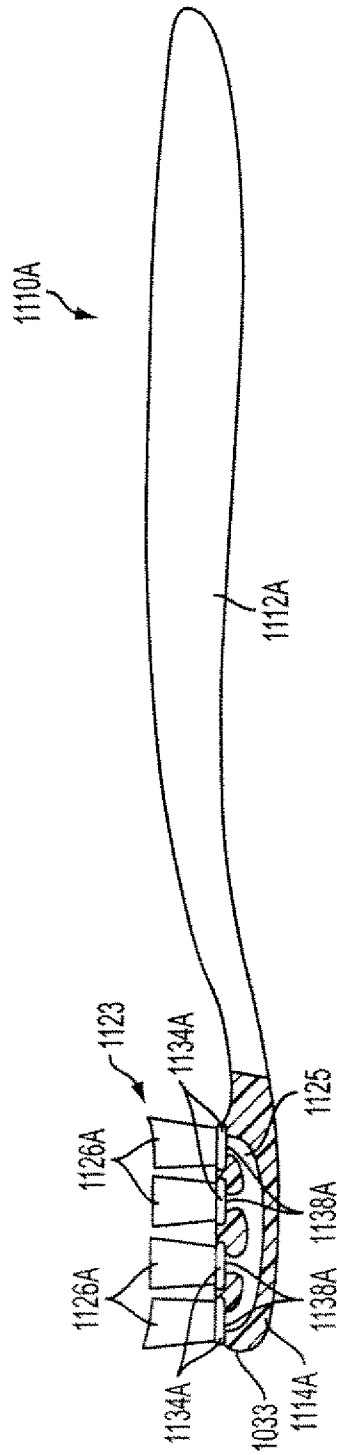

FIG. 6

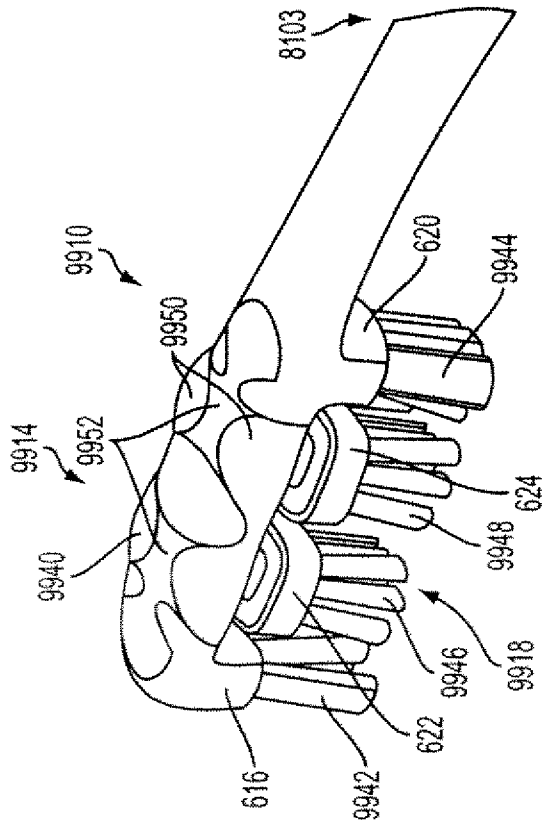

FIG. 7

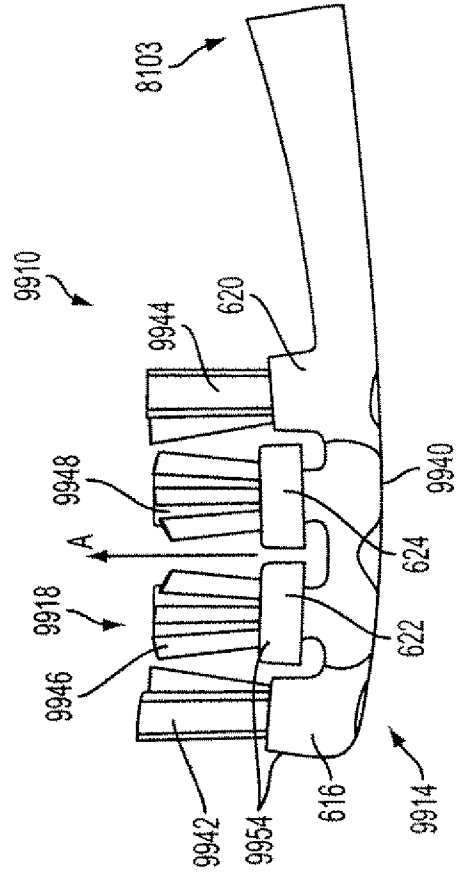

FIG. 8

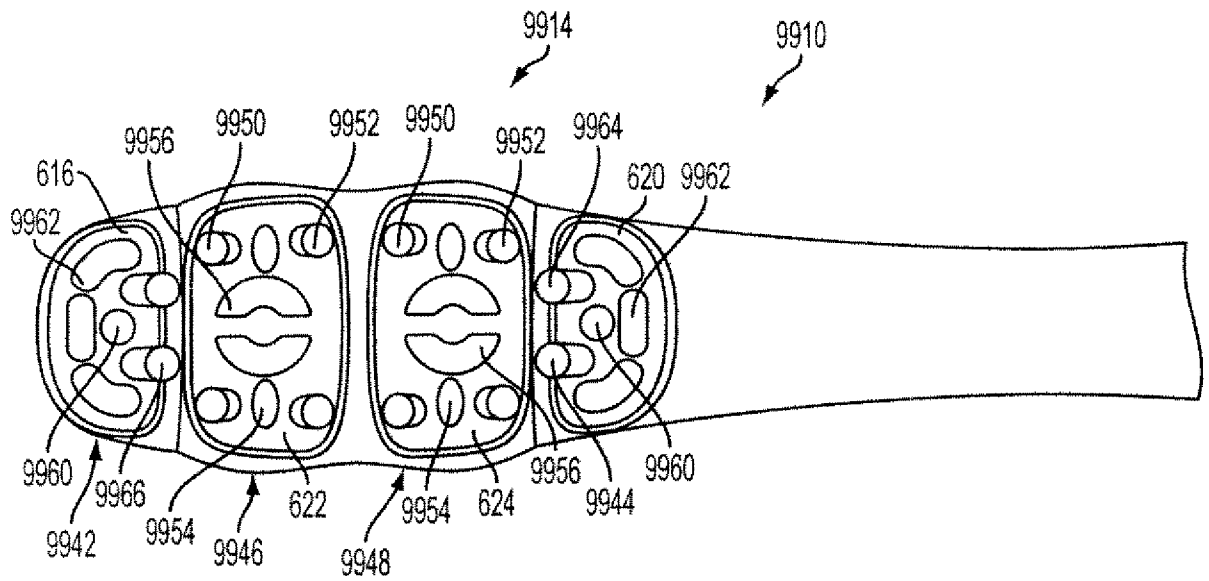

FIG. 9

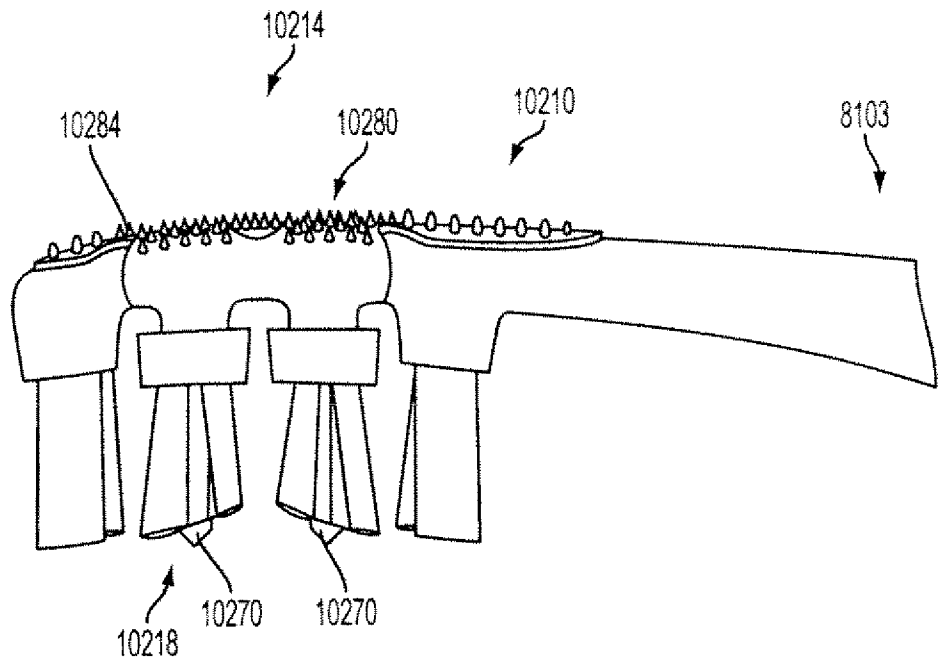

FIG. 10

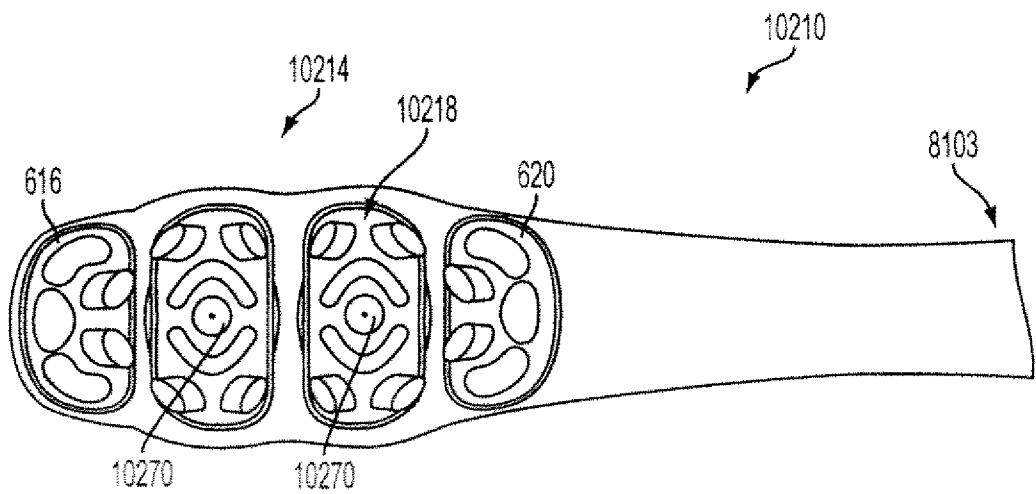

FIG. 11

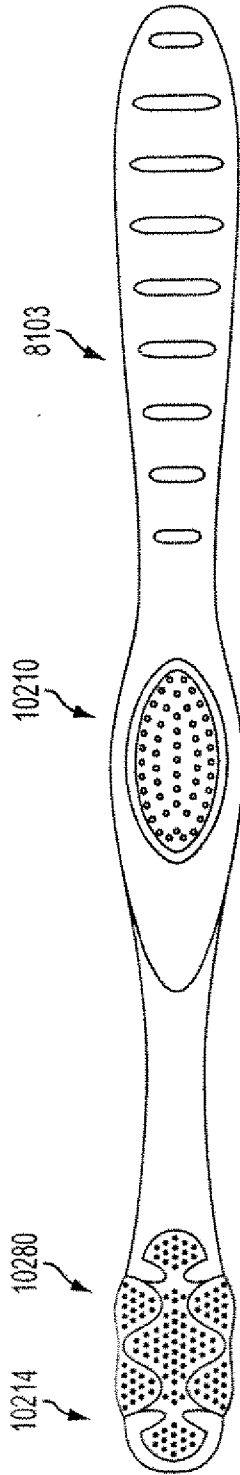

FIG. 12

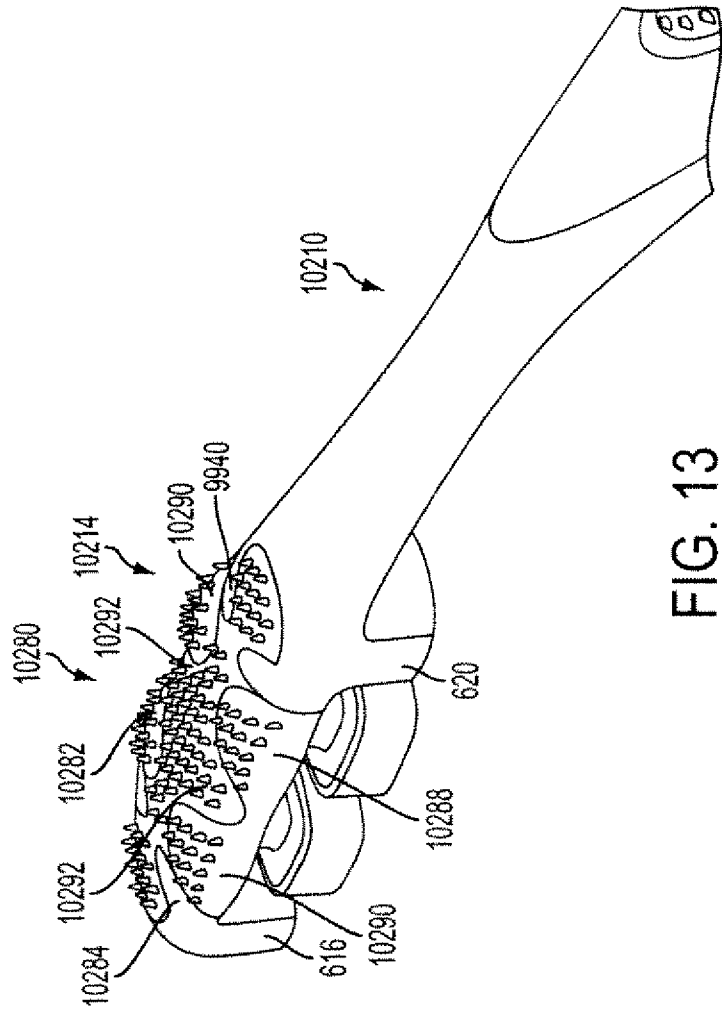

FIG. 13

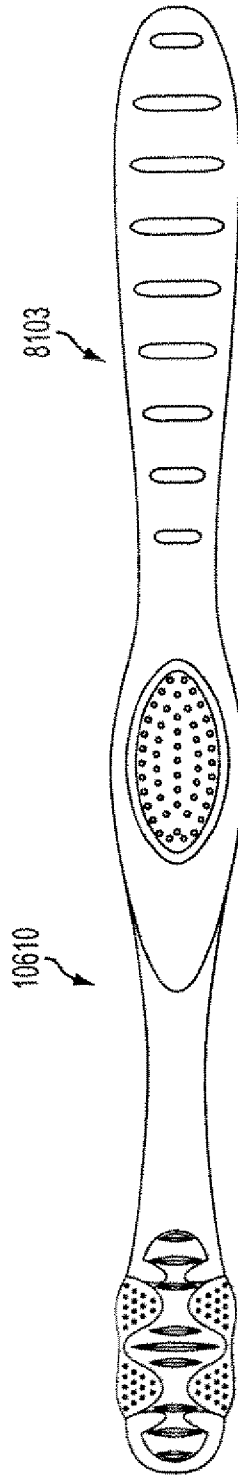

FIG. 14

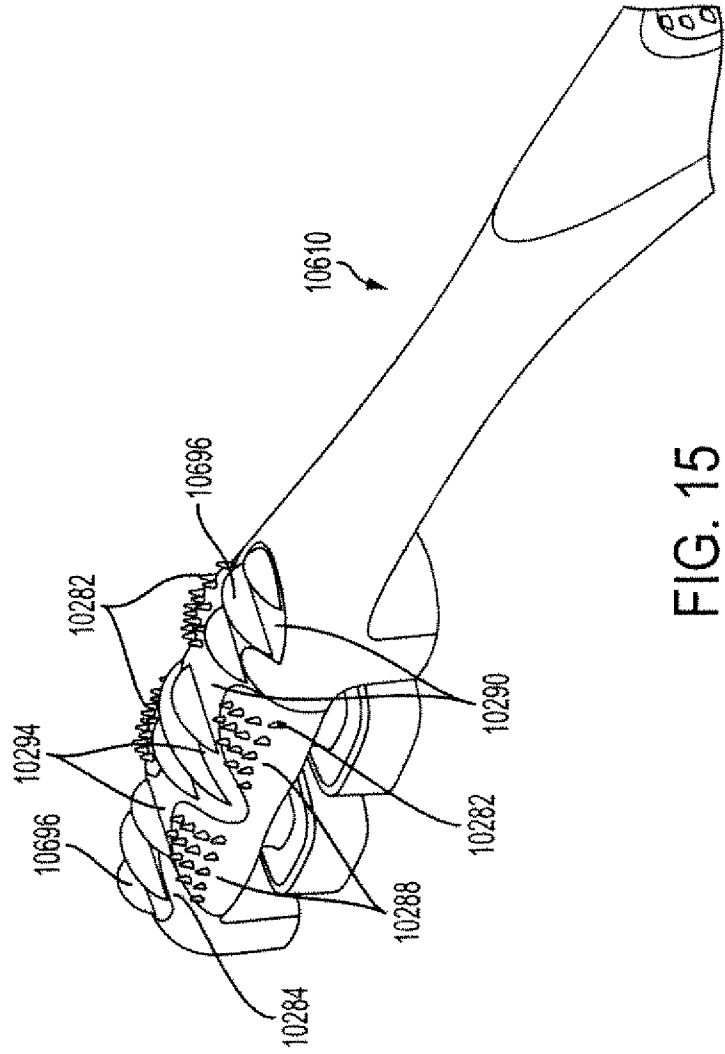

FIG. 15

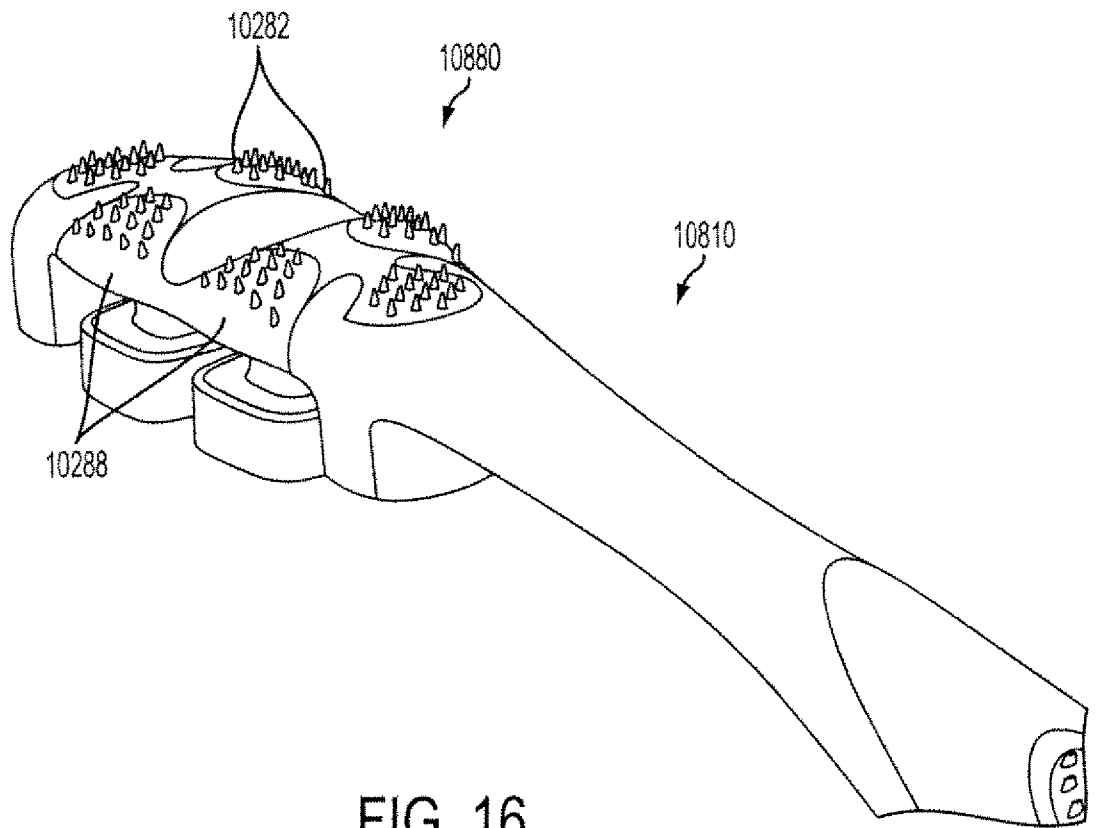

FIG. 16

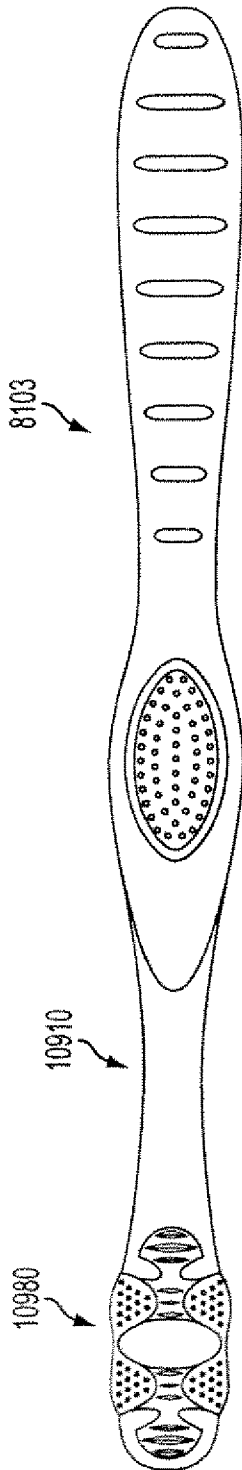

FIG. 17

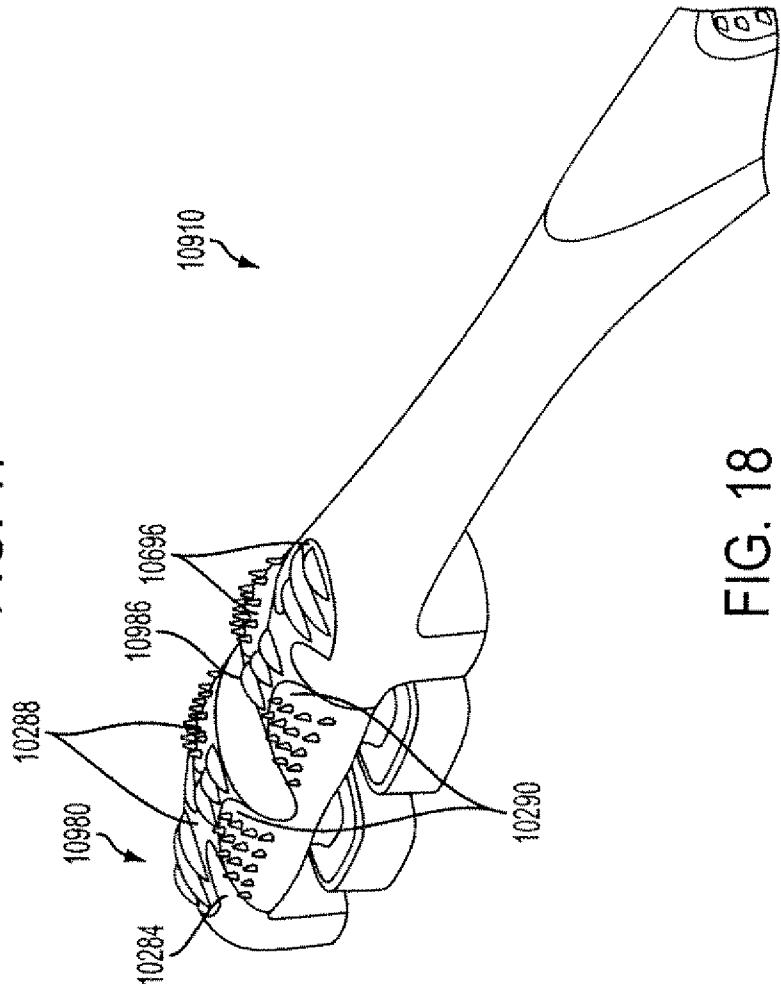

FIG. 18

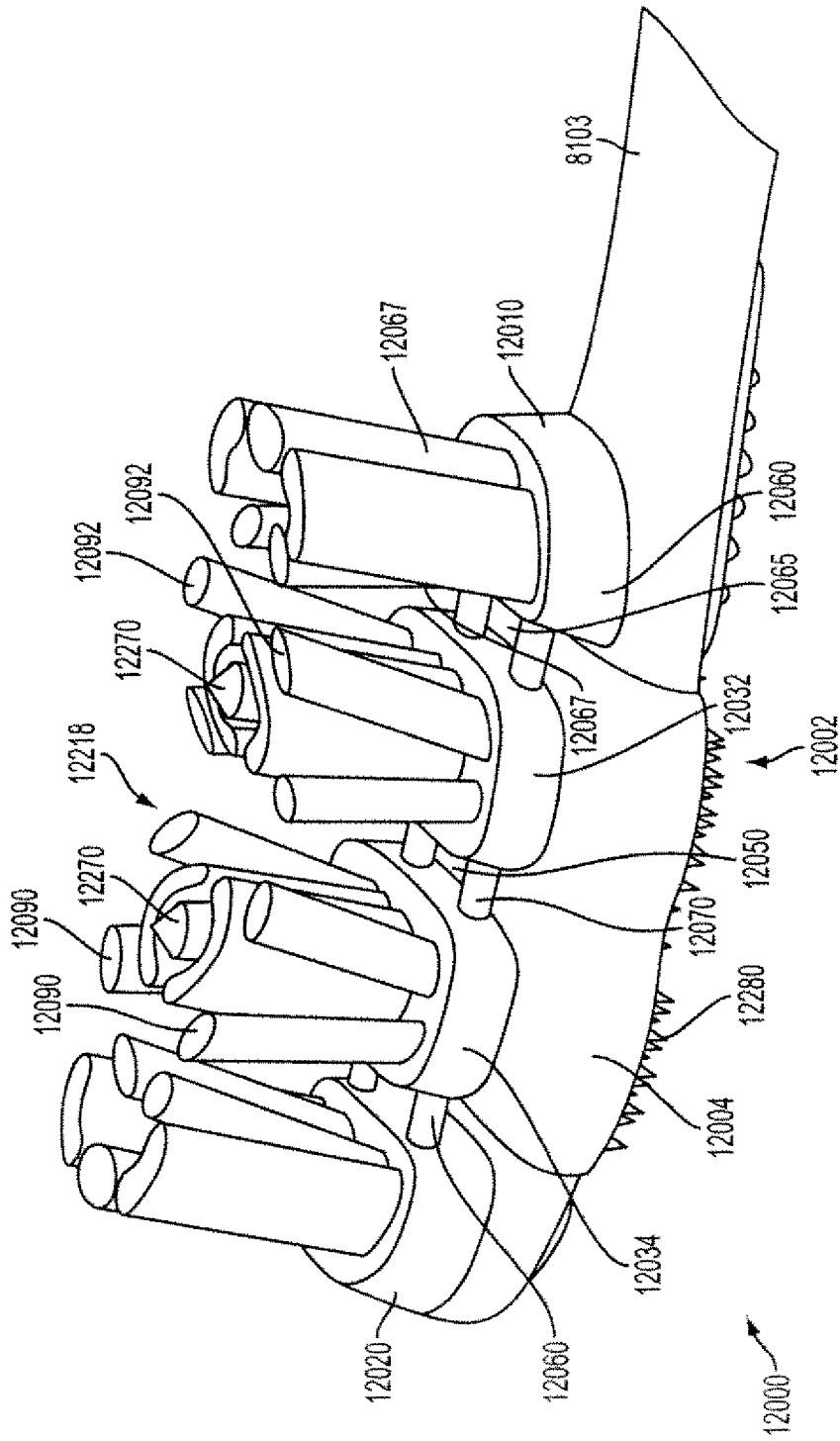

FIG. 19

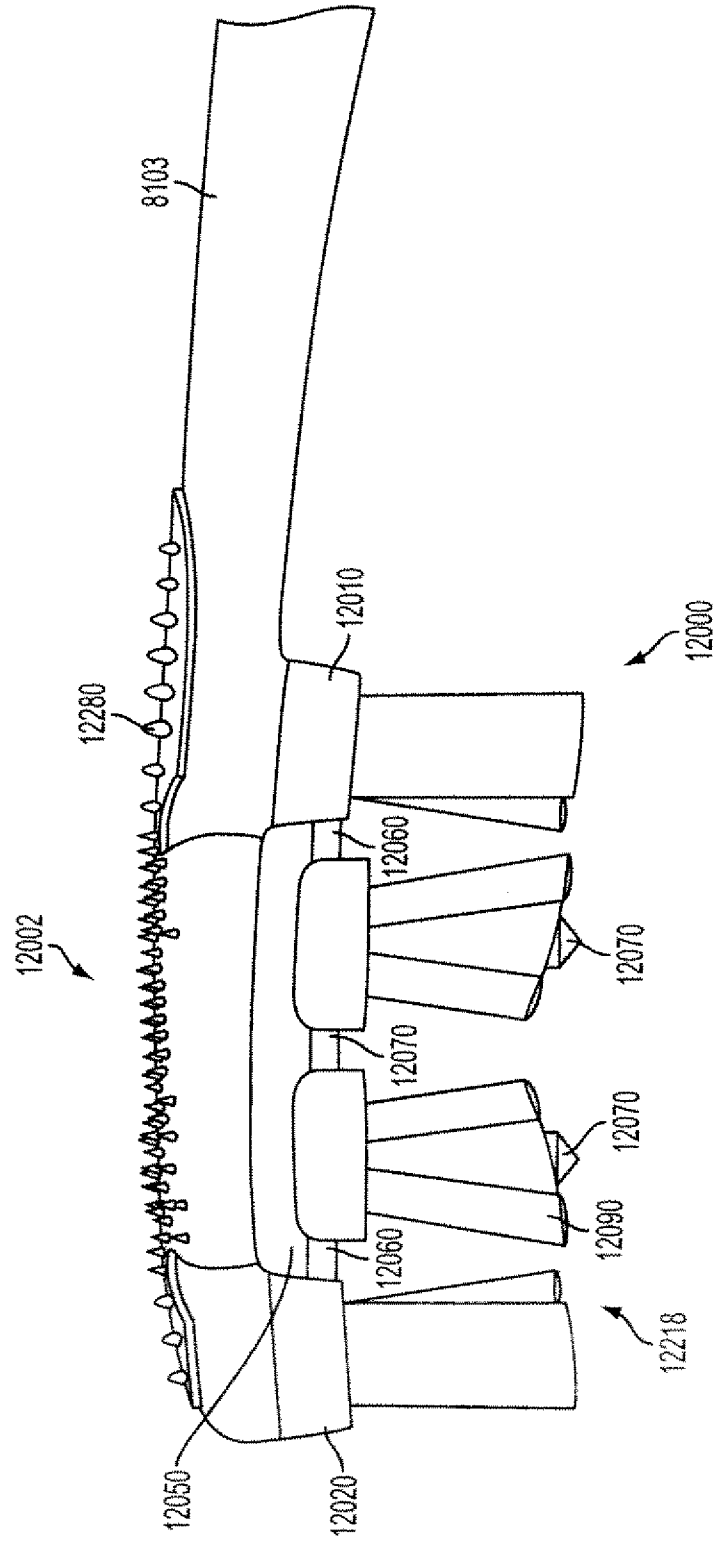

FIG. 20

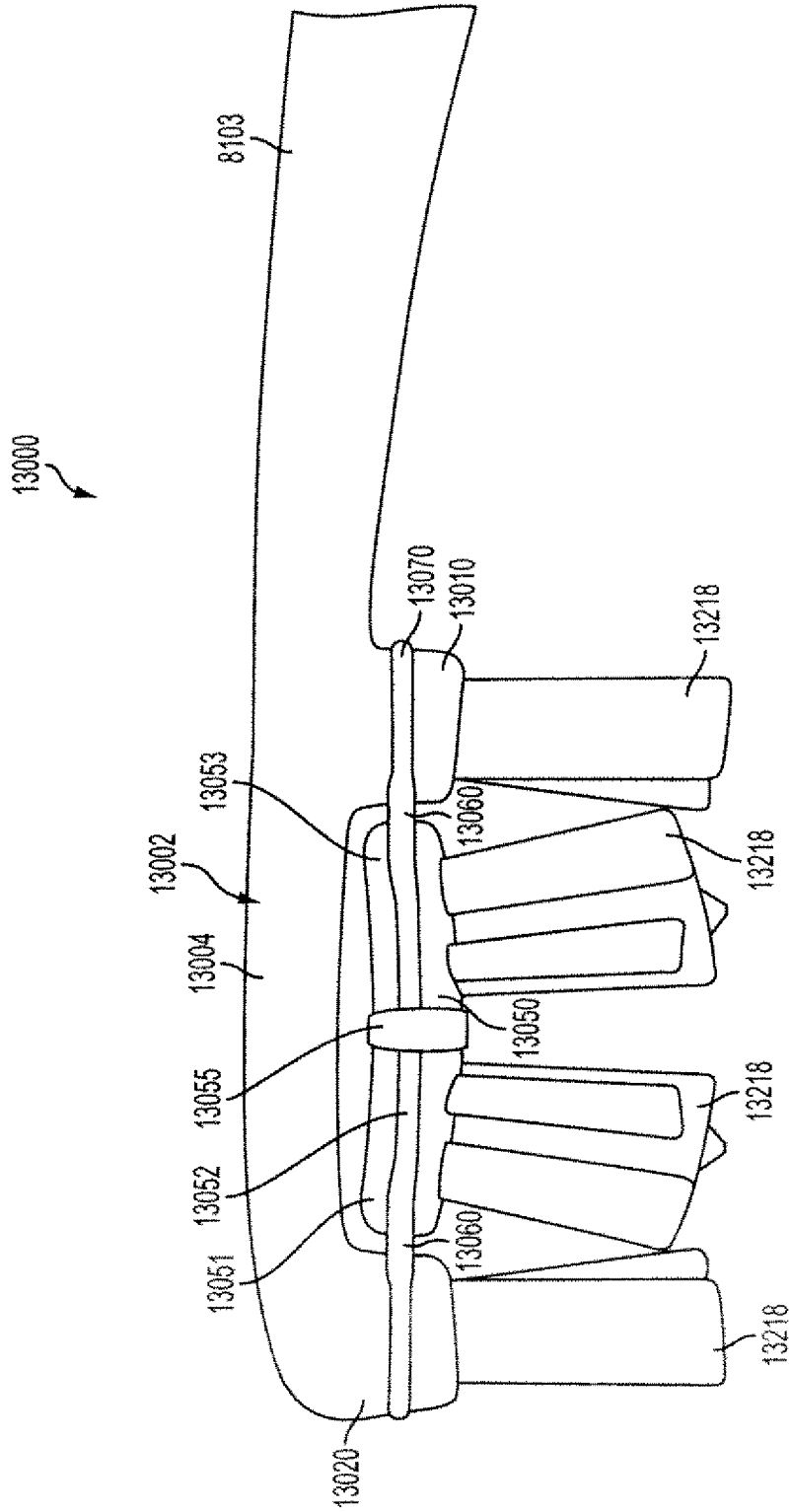

FIG. 21

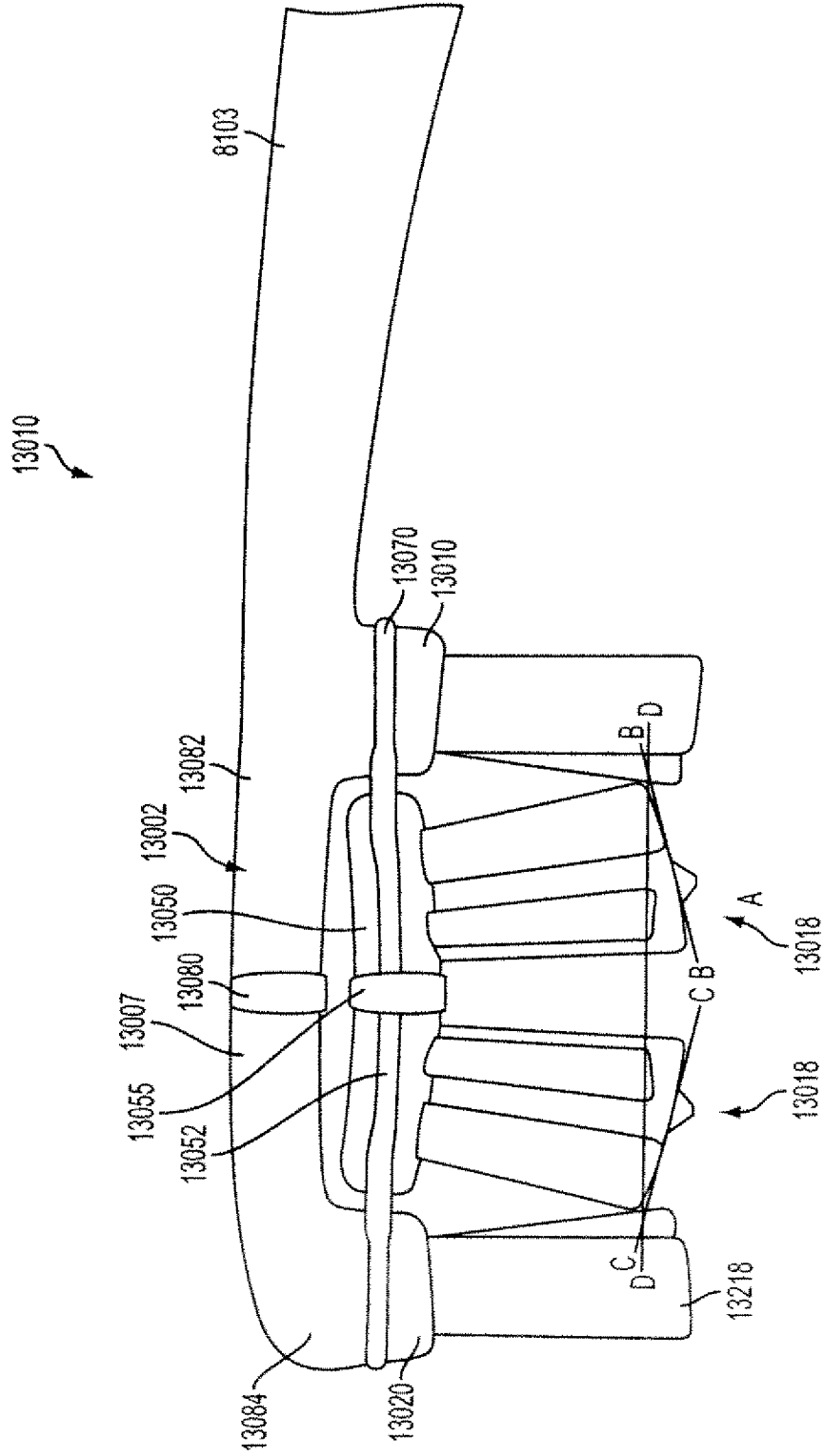

FIG. 22A

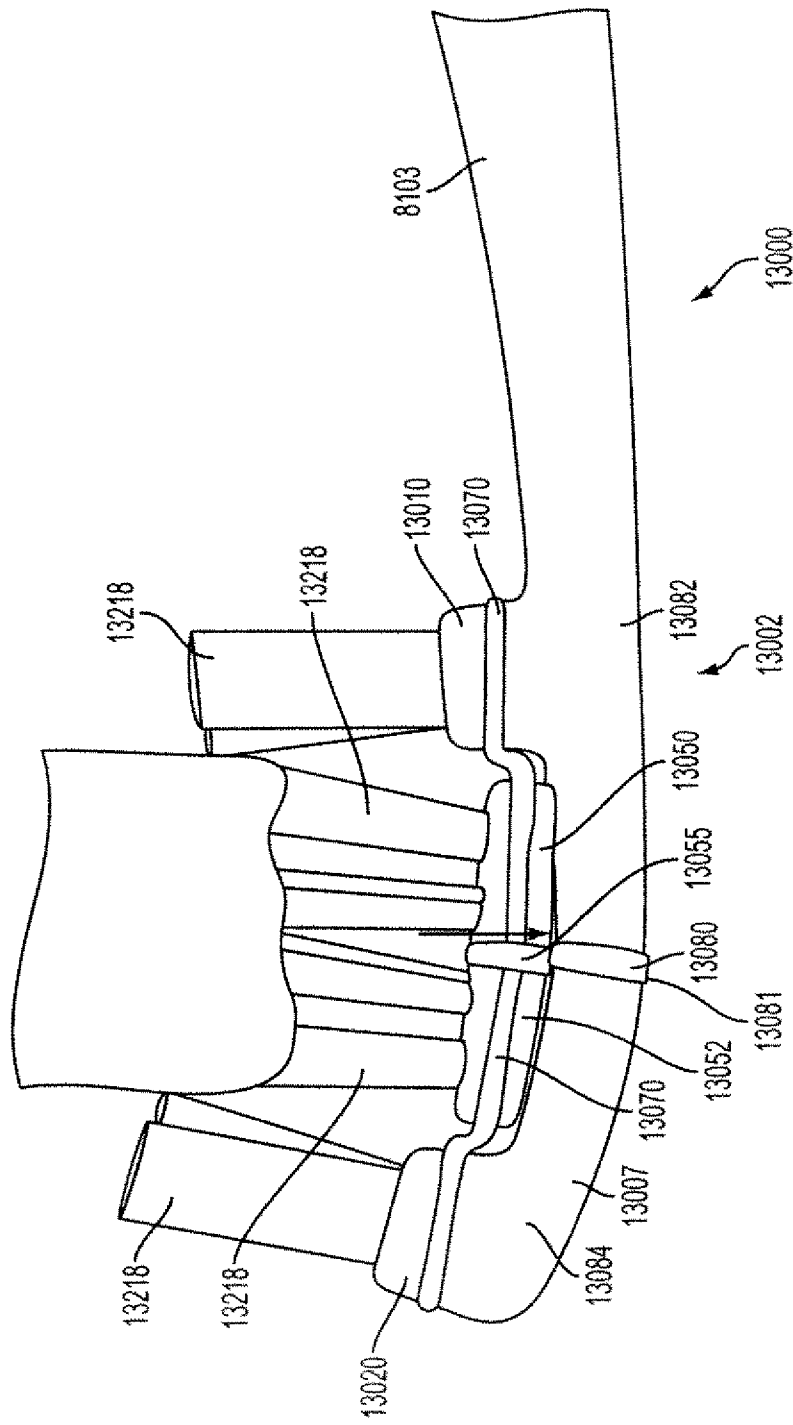

FIG. 22B

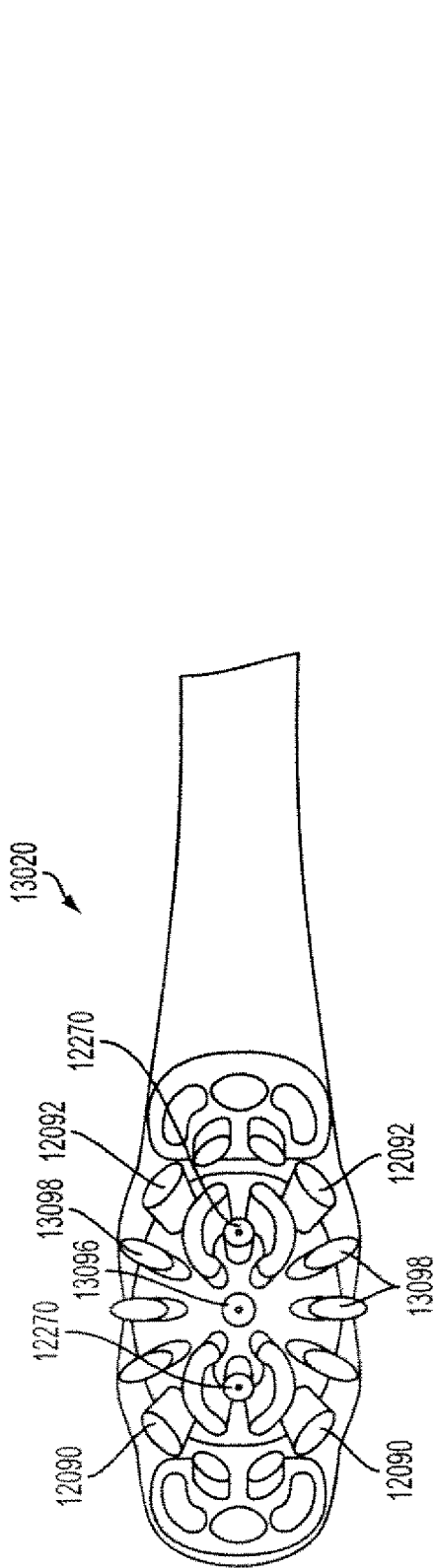

FIG. 23A

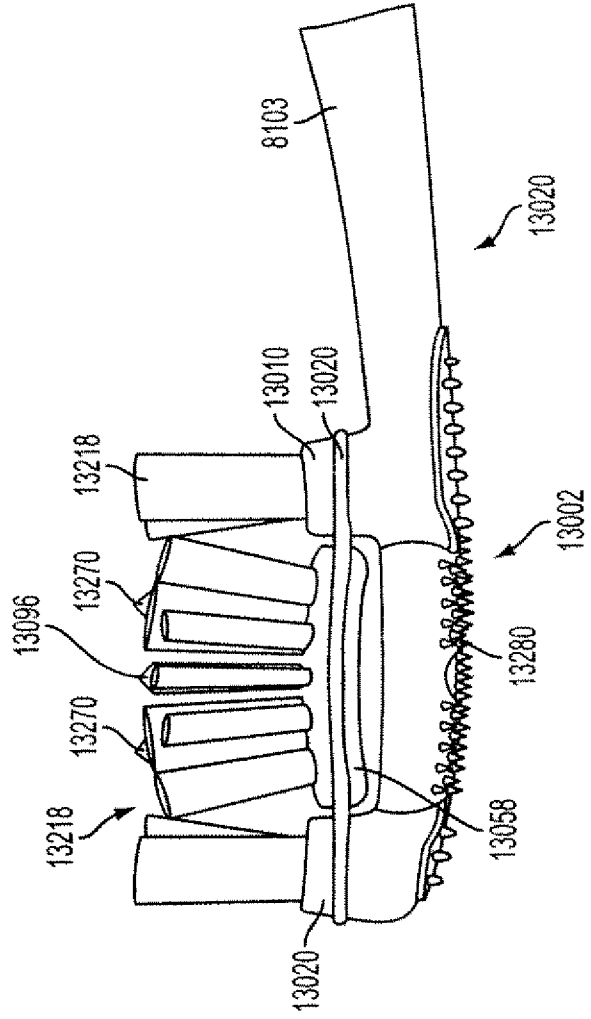

FIG. 23B

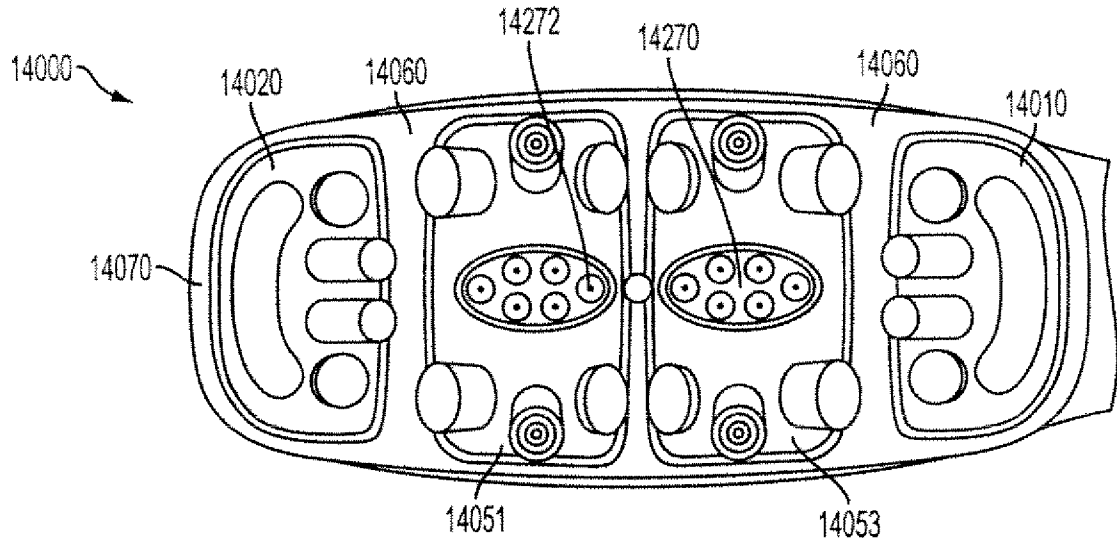

FIG. 24A

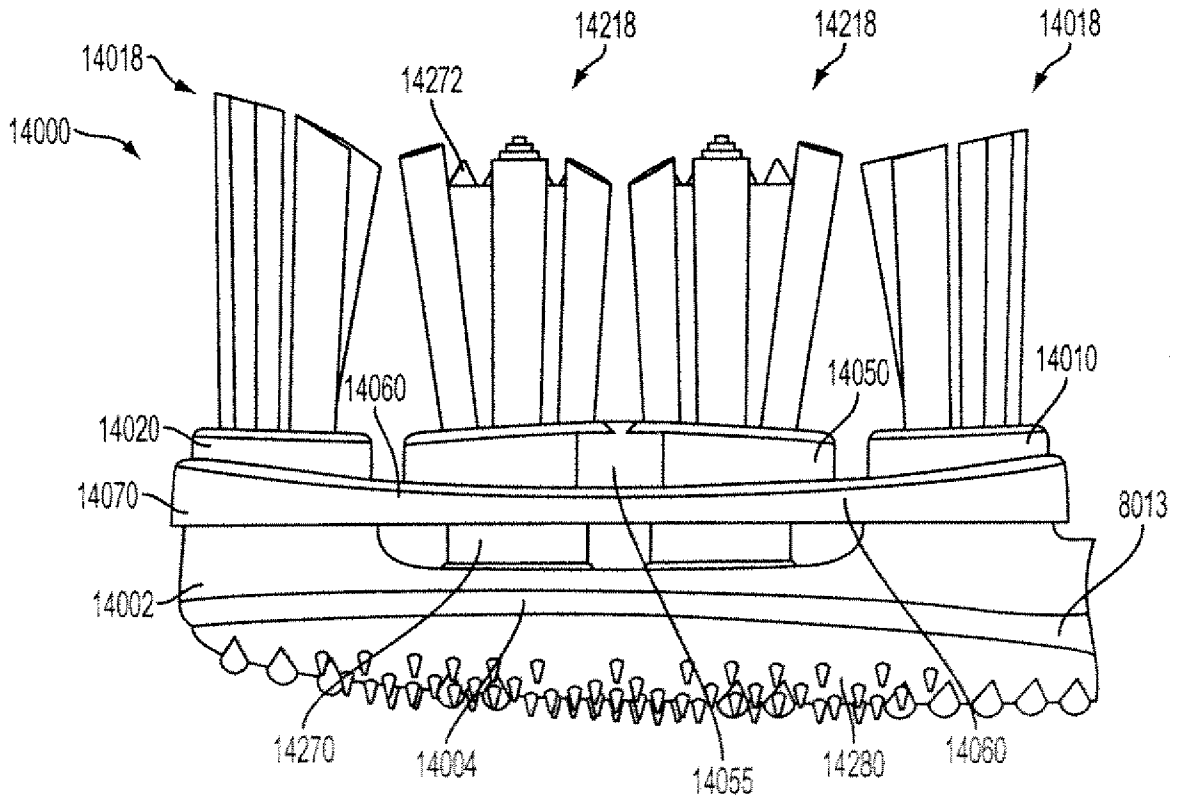

FIG. 24B

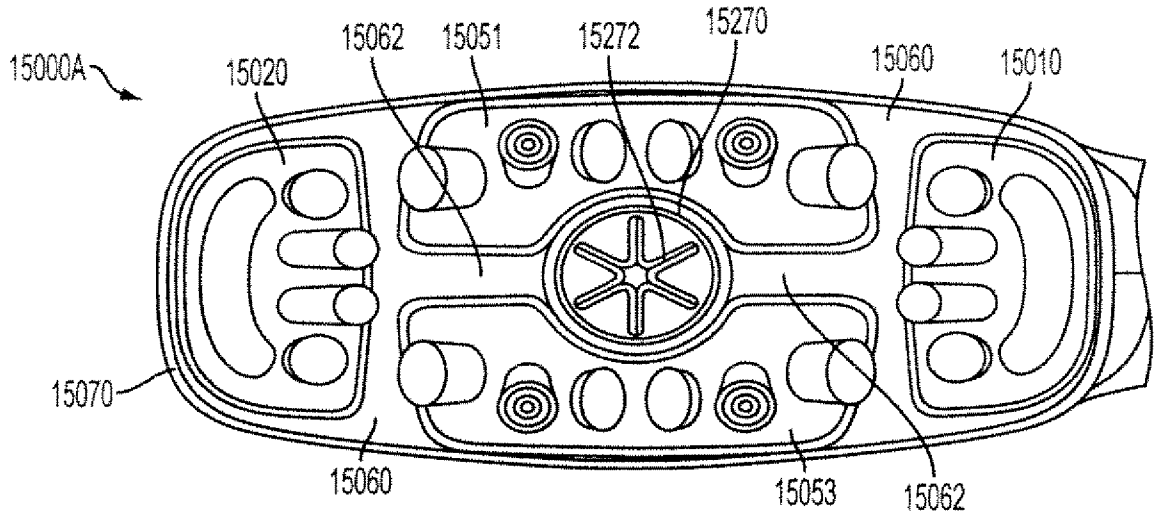

FIG. 25A

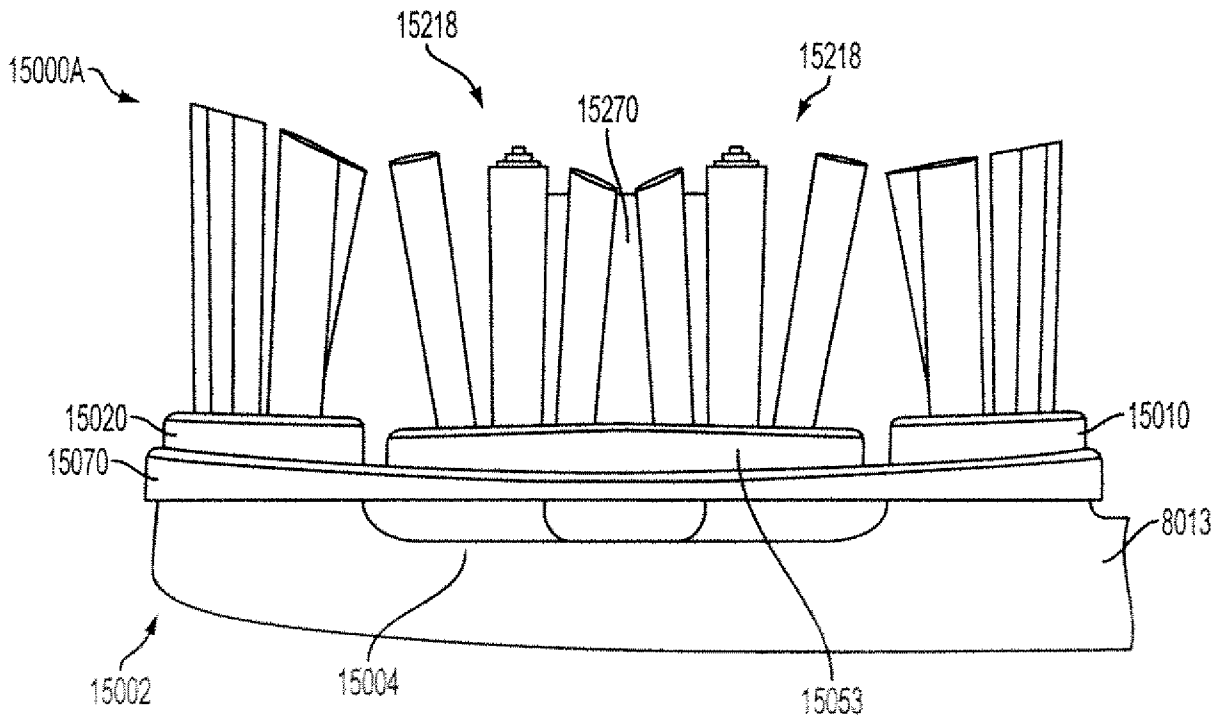

FIG. 25B

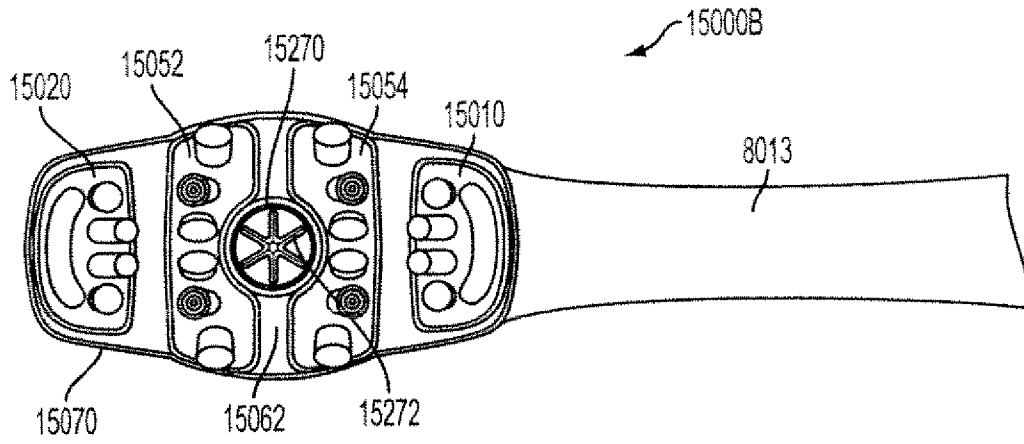

FIG. 25C

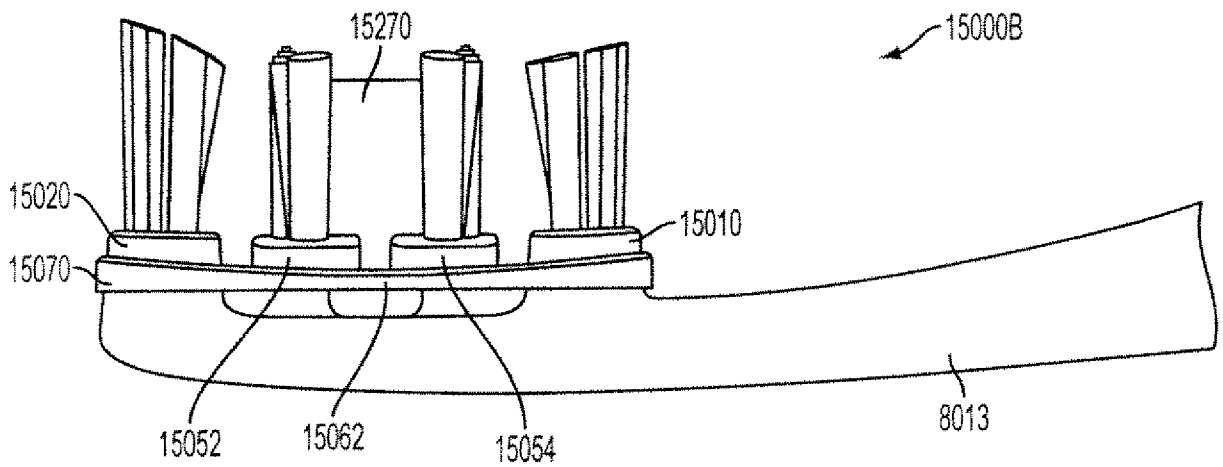

FIG. 25D

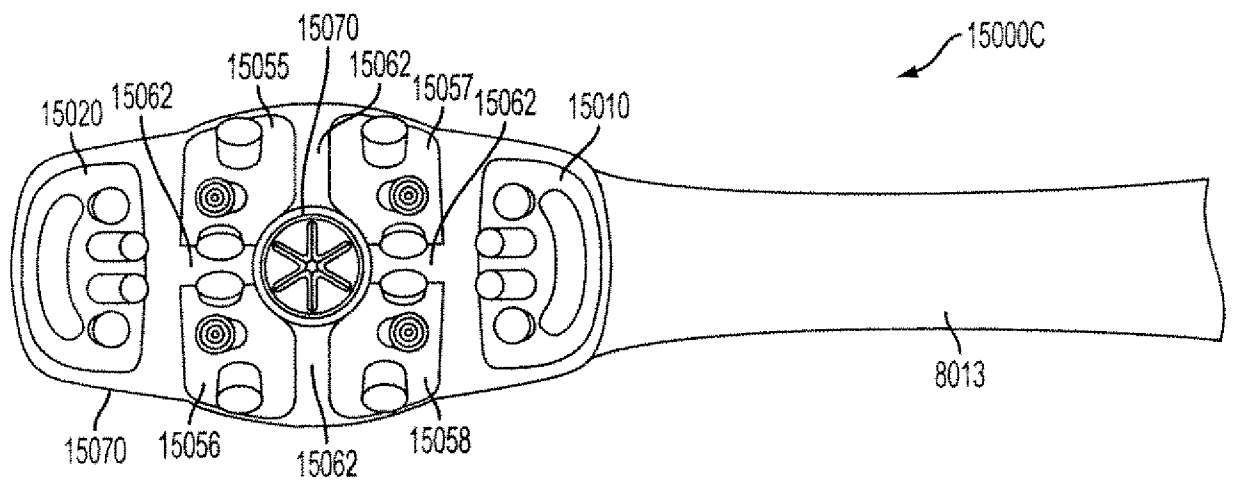

FIG. 25E

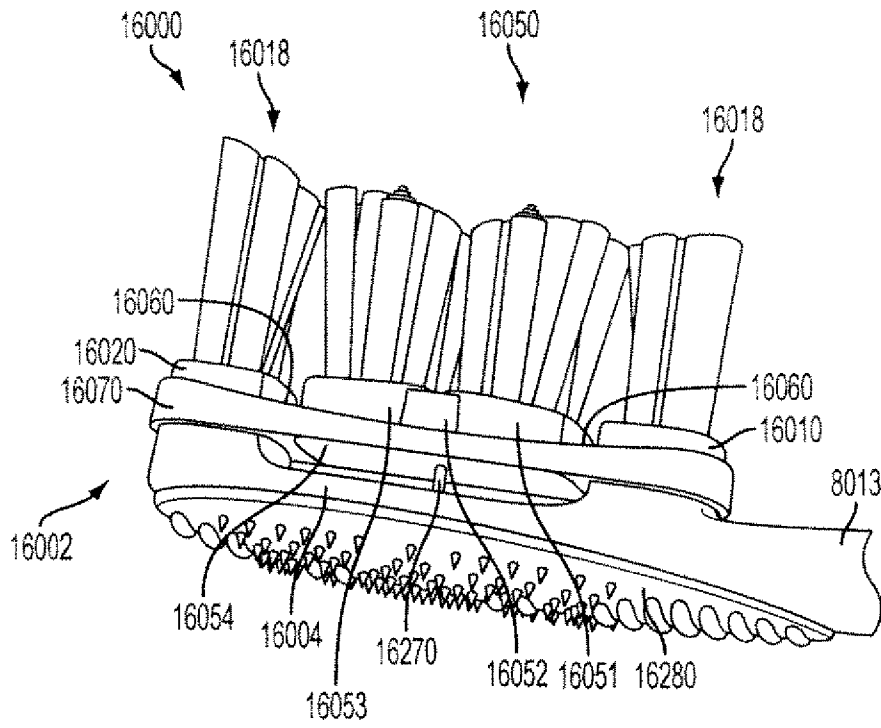

FIG. 26

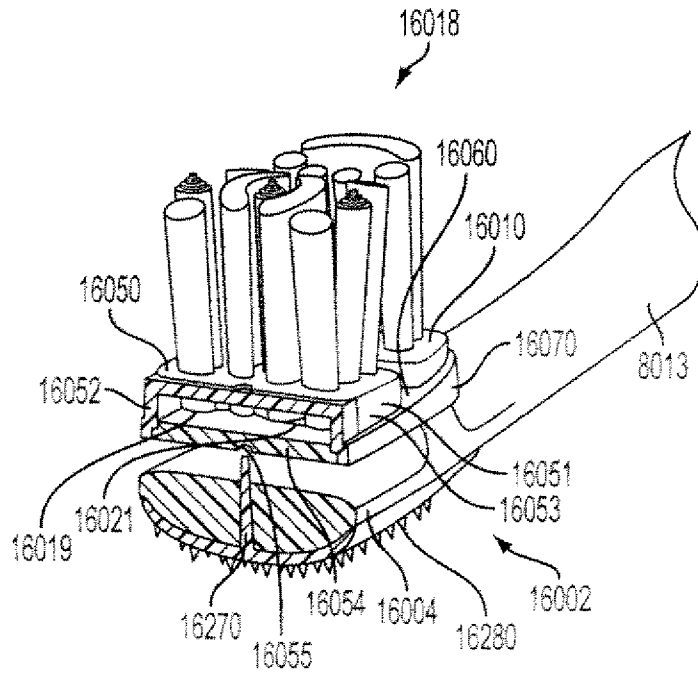

FIG. 27

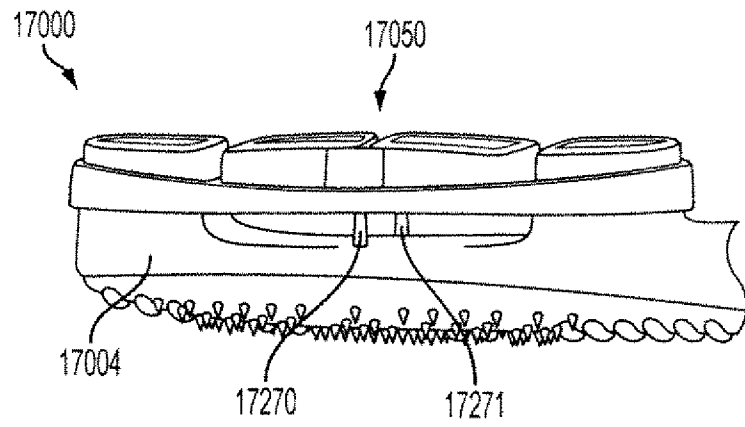

FIG. 28

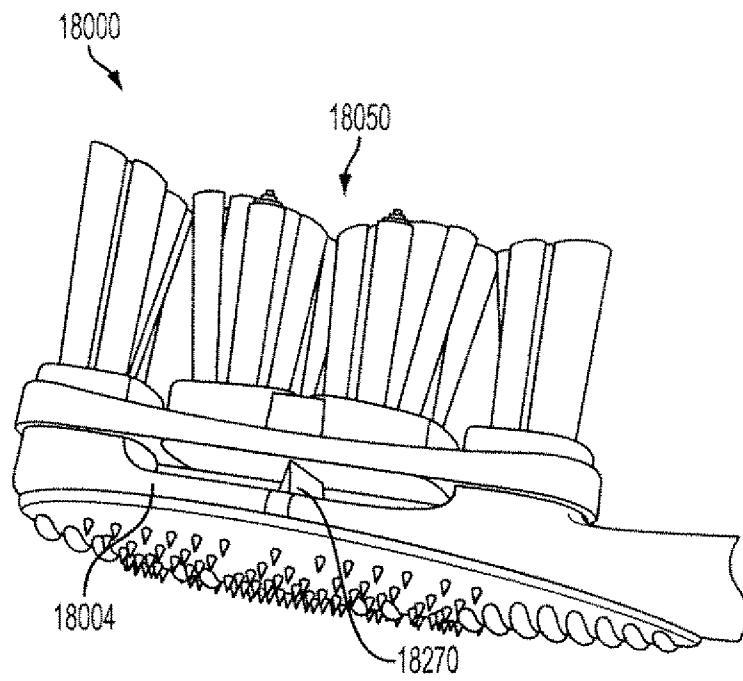

FIG. 29

INTERNATIONAL SEARCH REPORT

International application No
PCT/US2007/068435

A. CLASSIFICATION OF SUBJECT MATTER
INV. A46B7/06

According to International Patent Classification (IPC) or to both national classification and IPC

B. FIELDS SEARCHED

Minimum documentation searched (classification system followed by classification symbols)
A46B

Documentation searched other than minimum documentation to the extent that such documents are included in the fields searched

Electronic data base consulted during the international search (name of data base and, where practical, search terms used)

EPO-Internal

C. DOCUMENTS CONSIDERED TO BE RELEVANT

Category*	Citation of document, with indication, where appropriate, of the relevant passages	Relevant to claim No.
X A	US 2006/026784 A1 (MOSKOVICH) 9 February 2006 (2006-02-09) abstract paragraphs [0013], [0121] - [0123], [0127] - [0129], [0153] - [0156], [0160], [0230] figures 6-80,99-121 -----	1-17, 24-30, 32,33 18-23, 31,34
P,X	WO 2007/051099 A (COLGATE PALMOLIVE) 3 May 2007 (2007-05-03) claims 1-31 figures 1-25e -----	1-31

Further documents are listed in the continuation of Box C.

See patent family annex.

* Special categories of cited documents :

- "A" document defining the general state of the art which is not considered to be of particular relevance
- "E" earlier document but published on or after the international filing date
- "L" document which may throw doubts on priority claim(s) or which is cited to establish the publication date of another citation or other special reason (as specified)
- "O" document referring to an oral disclosure, use, exhibition or other means
- "P" document published prior to the international filing date but later than the priority date claimed

- "T" later document published after the international filing date or priority date and not in conflict with the application but cited to understand the principle or theory underlying the invention
- "X" document of particular relevance; the claimed invention cannot be considered novel or cannot be considered to involve an inventive step when the document is taken alone
- "Y" document of particular relevance; the claimed invention cannot be considered to involve an inventive step when the document is combined with one or more other such documents, such combination being obvious to a person skilled in the art.
- "&" document member of the same patent family

Date of the actual completion of the international search

12 October 2007

Date of mailing of the international search report

18/10/2007

Name and mailing address of the ISA/
European Patent Office, P.B. 5818 Patentlaan 2
NL - 2280 HV Rijswijk
Tel. (+31-70) 340-2040, Tx. 31 651 epo nl,
Fax: (+31-70) 340-3016

Authorized officer

WITKOWSKA-PIELA, A

INTERNATIONAL SEARCH REPORT

Information on patent family members

International application No

PCT/US2007/068435

Patent document cited in search report	Publication date	Patent family member(s)	Publication date
US 2006026784	A1	09-02-2006	NONE

WO 2007051099	A	03-05-2007	NONE
