

M. J. PALMER.
 ANGLE GAGE.
 APPLICATION FILED FEB. 3, 1913.

1,127,802.

Patented Feb. 9, 1915.

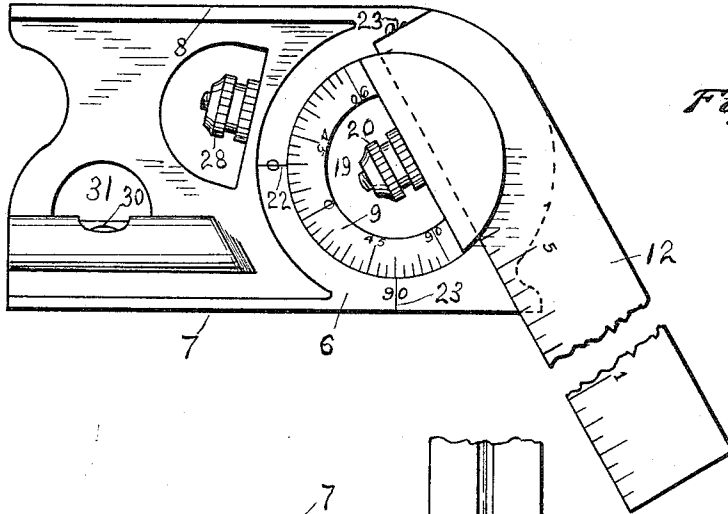

Fig. 1

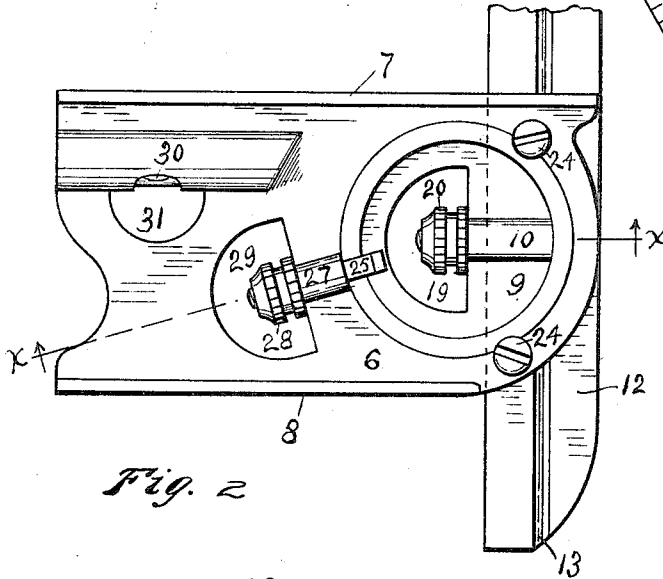

Fig. 2

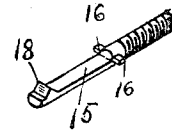

Fig. 5

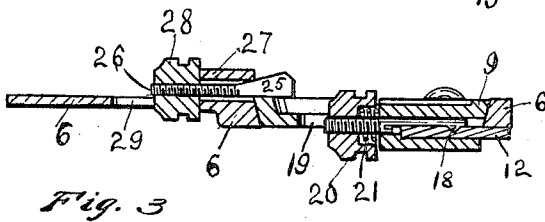

Fig. 3

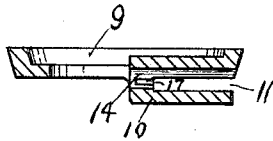

Fig. 4

WITNESSES:

F. C. Matheny
Frank Warren

INVENTOR
Martin J. Palmer
 BY
C. D. Haskins
 ATTORNEY

UNITED STATES PATENT OFFICE.

MARTIN J. PALMER, OF SEATTLE, WASHINGTON.

ANGLE-GAGE.

1,127,802.

Specification of Letters Patent.

Patented Feb. 9, 1915.

Application filed February 3, 1913. Serial No. 745,790.

To all whom it may concern:

Be it known that I, MARTIN J. PALMER, citizen of the United States, residing at Seattle, in the county of King and State of Washington, have invented a certain new and useful Improvement in Angle-Gages, of which the following is a specification.

My invention relates to improvements in adjustable angle gages that are adapted to determine the angular relation between two sides or surfaces of a body, and the object of my improvement is to provide a gage that shall be adapted to be adjusted quickly and with accuracy to any desired angle and which shall be simple in construction and operation. I attain this object by devices illustrated in the accompanying drawings, wherein—

Figure 1 is a view in front side elevation of a gage embodying my invention, Fig. 2 is a view in rearward elevation of the same, Fig. 3 is a view of a section of the same on broken line *x, x*, of Fig. 2, Fig. 4 is a view in cross-section of a detail of the same, and Fig. 5 is a view in perspective of another detail thereof.

Like reference numerals indicate like parts throughout the drawings.

Referring to the drawings, 6 is a frame-plate having parallel edges 7 and 8 respectively one end of which frame 6 is rounded as shown. Adjacent to the rounded end of said frame-plate 6 and concentric therewith is bored a circular and tapered hole or opening within which is fitted a circular dial-plate 9 whose form is more clearly shown by a view in transverse section in Fig. 4. The said dial-plate 9 is provided with a semi-cylindrical boss 10 on its underside which is slotted in a plane parallel with the bottom surface of said dial-plate 9 to provide a recess 11 within which may be disposed a rule or gage-blade 12 that is adapted to move endwise within said recess 11. One side of said gage-blade 12 is provided with a V shaped groove 13 extending throughout its length.

A hole 14 is drilled lengthwise of the boss 10 which is adapted to receive a screw-threaded clamp 15 whose form is more clearly illustrated in Fig. 5. Said clamp 15 is provided with a guide pin whose ends 16, 16 are disposed to fit and move in a slot 17 formed in the dial-plate 9 at a point near the inner end of the boss 10, (as shown in Figs. 3 and 4) when said clamp 15 is disposed

within hole 14 in which position an angular projection 18 on said clamp 15 may engage with the groove 13 of the gage-blade 12 as more clearly shown in Fig. 3. The screw-threaded portion of the clamp 15 projects outwardly from the hole 14 into a semi-circular opening 19 in the dial-plate 9 and such screw-threaded portion is provided with a milled nut 20 which is adapted to control the lengthwise position of the clamp 15 and its angular projection 18 whereby the gage-blade 12 may be clamped tight by being drawn with greater pressure against the bottom of the recess 11 by the action of the angular projection 18. The milled nut 20 is counterbored on its inner end and within the recess thus formed is disposed a compressible spiral spring 21 which may serve as a frictional device to prevent the milled nut 20 from turning too freely. Thus the gage-blade 12 may be moved endwise within the recess 11 to any desired point, when the milled nut 20 is loosened, and be securely fastened at such point by turning the milled nut 20 to force the angular projection 18 to clamp the gage-blade 12 in an obvious manner.

The dial-plate 9 on its front side is provided with a scale indicating the degrees of its circle from a zero point to a distance of ninety degrees on each side of such zero point, as shown in Fig. 1, and upon the front side of the frame-plate 6 is a zero mark 22 at a point midway between the edges 7 and 8, extending to the edges of the dial-plate 9, and a 90 degree mark 23, 23 on each side of the zero mark 22 at a distance of 90 degrees as shown.

The dial-plate 9 is retained within its conical seat by binding screws 24, 24 and a wedge shaped clamping device 25 disposed on the rear side of the frame-plate 6 as shown in Fig. 2. The wedge shaped clamping device 25 is provided with a screw threaded shank 26 which extends through a boss 27 of semi-cylindrical form which projects from the frame-plate 6, as indicated in Fig. 2, but more clearly illustrated in Fig. 3. A milled nut 28 is adapted to fit said screw threaded shank 26 and by its operation the wedge shaped clamp 25 may be drawn within the boss 27 to force the clamping device 25 downwardly upon the surface of the dial-plate 9 to securely fasten such dial-plate 9 in any desired position whereby the gage-plate 12 may be disposed

at a desired angle with respect to the edges 7 and 8 of the frame-plate 6. A semi-circular opening 29 in the frame-plate 6 serves to give room for the milled nut 28.

5 In the frame-plate 6 adjacent to the edge 7 thereof I have provided a liquid level 30 of well known type, and a semi-circular opening 31 that extends through the frame-plate 6 whereby the level 30 may be observed from either side of the frame-plate 6. Such level 30 may act conjointly with the gage-blade 12 to enable one to determine the angular position of an object with respect to any point on a horizontal line.

15 Obviously to operate an angle gage embodying my invention, one would loosen the milled nut 20 to permit the gage-blade 12 to be moved endwise to a desired position and thereupon turn said milled nut 20 to clamp the said gage-blade 12 with its edge fast against the recess 11, then the milled nut 28 would be loosened to free the wedge shaped clamping device 25, thus to permit the dial-plate 9 to be turned to a desired angle which angle might be determined by the scale on the dial-plate 9 whereupon the milled nut 28 would be turned to cause the clamping device 25 to press against the dial-plate 9 to secure it in its tapered seat, the screws 24 in their fixed position being adapted to permit the dial-plate 9 to be turned only when the clamping device 25 is loose.

35 Manifestly the parts of a structure embodying my invention may be modified with respect to form and dimensions without departing from the spirit thereof.

What I claim is:

1. In an angle gage, the combination with a frame-plate having a tapered circular opening, of a dial-plate peripherally beveled to rotate within said opening and formed with a slot, a gage-blade having a longitudinal groove, and means for clamping said blade in adjusted position with relation to the dial-plate, comprising a boss on said dial-plate formed with a recess to receive said blade, a threaded clamp having a pin guided in the slot in the dial-plate, and a transverse projection fitting the groove in said blade, and a nut on the threaded end of said clamp.

2. In an angle gage, the combination with a frame-plate having a tapered circular opening, of a dial-plate rotatably fitting within said opening and provided with a hollow boss, a gage-blade longitudinally adjustable on said plate, means for clamping said blade in adjusted position with relation to said dial-plate, and means for securing said dial-plate to said frame plate comprising binding-screws extending into said frame-plate, and a clamping device consisting of a wedge engaging the dial-plate and having a threaded extension extending through said hollow boss, and a clamping-nut on said threaded extension.

In witness whereof, I, hereunto subscribe my name this seventeenth day of January A. D., 1913.

MARTIN J. PALMER.

Witnesses:

ANNA HASKINS,
GEO. BLAIR.

Copies of this patent may be obtained for five cents each, by addressing the "Commissioner of Patents, Washington, D. C."