

(No Model.)

3 Sheets—Sheet 1.

W. L. TOBEY.  
STREET SWEEPER.

No. 525,751.

Patented Sept. 11, 1894.

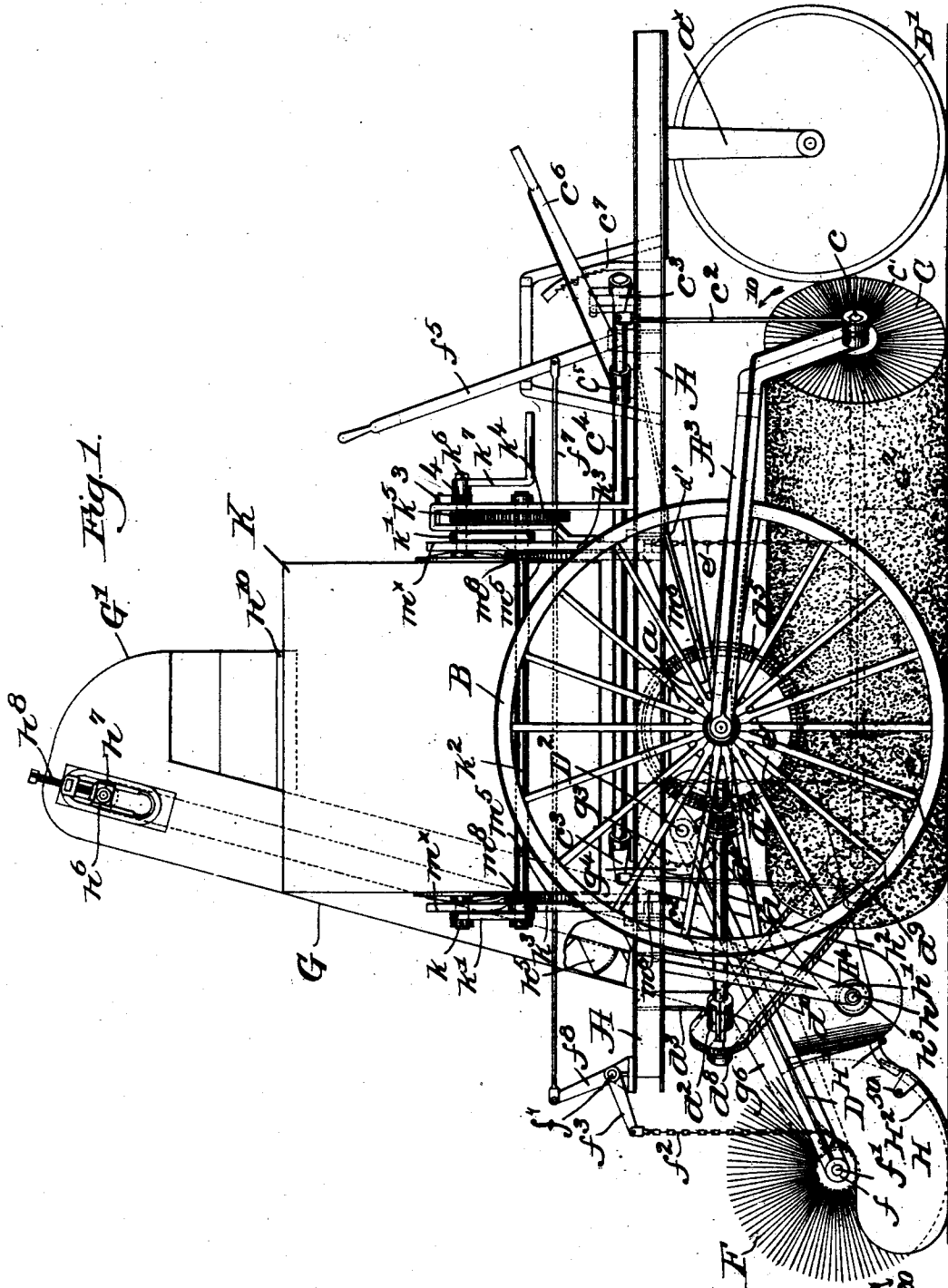

Witnesses.  
 Fred S. Greenleaf  
 Thomas Drummond

Inventor.  
 William L. Tobey,  
 by Crosby & Grey  
 attys.



(No Model.)

3 Sheets—Sheet 3.

W. L. TOBEY.  
STREET SWEEPER.

No. 525,751.

Patented Sept. 11, 1894.

Fig. 3.

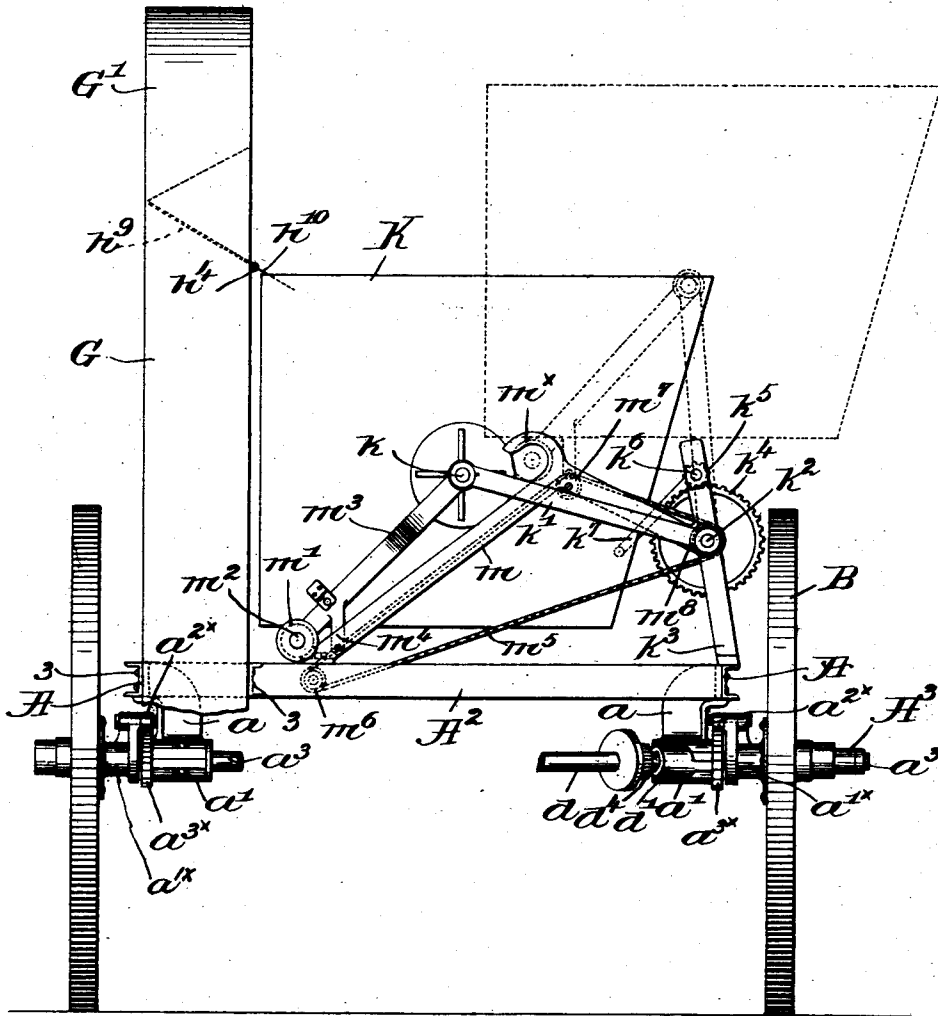

Witnesses.

Fred S. Gunkel  
Thomas J. Dimmond

Inventor.  
William L. Tobey,  
by Crosby Gregory  
attys.

# UNITED STATES PATENT OFFICE.

WILLIAM L. TOBEY, OF BOSTON, MASSACHUSETTS, ASSIGNOR TO THE UNIVERSAL STREET SWEEPING MACHINE COMPANY, OF SAME PLACE.

## STREET-SWEEPER.

SPECIFICATION forming part of Letters Patent No. 525,751, dated September 11, 1894.

Application filed December 29, 1893. Serial No. 495,078. (No model.)

*To all whom it may concern:*

Be it known that I, WILLIAM L. TOBEY, of Boston, county of Suffolk, State of Massachusetts, have invented an Improvement in Sweeping-Machines, of which the following description, in connection with the accompanying drawings, is a specification, like letters and figures on the drawings representing like parts.

This invention has for its object the production of a sweeping machine which will sweep up the dirt in an efficient and rapid manner, and will thereafter collect the sweepings in a suitable receptacle carried by the machine, said receptacle being so arranged that it can be readily discharged when full into a cart, or in a pile, as desired.

In accordance therewith my invention consists, in a sweeping machine, of a sweeper brush to collect the sweepings, a pivotally supported pan having an independent curved bottom pivoted to the sides of the pan and adapted to rest upon and trail over the surface to be swept just in advance of the loading brush, and a cylindrical loading brush to force the sweepings over said bottom and pan onto a conveyer to convey the sweepings to a suitable receptacle, substantially as will be described.

Other features of my invention will be hereinafter described and particularly pointed out in the claims.

Figure 1 is a side elevation, partially broken out, of a sweeping machine embodying my invention. Fig. 2 is a top or plan view thereof; and Fig. 3 is a rear elevation of a sufficient part of the machine shown in Fig. 2, to be understood, to more particularly show the receptacle for the sweepings and the mechanism for raising and lowering it.

I have herein shown my invention as embodied in a frame A, of suitable shape to support the operating parts to be described, the said frame being preferably constructed of channel iron suitably bolted together and provided with suitable bearings to be referred to, front and rear braces A' and A<sup>2</sup> maintaining the frame rigid.

Brackets a secured to the sides of the frame form bearings a', shown in dotted lines Fig.

2 and in full lines Fig. 3, for a rotatable shaft a<sup>3</sup> projecting at its ends beyond the sides of the frame A and having secured thereto supporting wheels B, said wheels being loose on the shaft, the hubs a'<sup>x</sup> of said wheels being provided at their inner sides with like pawls a<sup>2x</sup> to engage ratchet wheels a<sup>3x</sup> fast on the main shaft a<sup>3</sup>, so that retrograde movement of the machine will not rotate the main shaft, and by means of the pawl and ratchet connections the apparatus can turn sharp corners very easily, the main shaft being rotated by the wheels B as the machine is drawn along over the surface to be swept.

A suitable traction wheel B' is swiveled to the front of the frame by a suitable bracket a<sup>x</sup>, see Fig. 1, the machine being guided in its movements by means of said traction wheel.

The sweeper brush C, of any usual or desired construction, is arranged diagonally with relation to the path of movement of the machine, as best shown in Fig. 2, the axis c of the brush projecting beyond the ends thereof and having bearings c' attached to the lower ends of depending links c<sup>2</sup>, said links being in turn pivotally connected to arms c<sup>3</sup> of a rock-shaft c<sup>4</sup> mounted in sleeve-like bearings c<sup>5</sup> secured to the frame A, said rock-shaft having attached thereto an actuating lever c<sup>6</sup>, by means of which the sweeper brush may be raised or lowered to adjust it to the surface to be swept, or to raise the brush altogether from contact therewith.

A suitable notched or other segment c<sup>7</sup> is adapted to be engaged by the lever c<sup>6</sup> to hold the brush at the desired elevation.

A bent arm A<sup>3</sup> is pivotally supported at one end by the portion of the shaft a<sup>3</sup> projecting beyond the hub of the supporting wheel B, the other end of the arm terminating in the bearing c', hereinbefore described, while an arm a<sup>4</sup> has formed in it the other bearing c' at the opposite end of the sweeper brush, said arm being pivoted on a shaft to be described. In order to give greater rigidity to the arm A<sup>3</sup>, a brace A<sup>5</sup> is rigidly secured thereto near one end, the other end of the brace being pivoted to the frame at A<sup>6</sup>, see Fig. 2. The arms A<sup>3</sup> and A<sup>4</sup> thus form a strong and durable

supporting frame for the sweeper brush, the pivotal arrangement of said arms enabling the brush to rise and fall as it passes over inequalities in the surface to be swept.

5 Referring to Fig. 2, it will be seen that the leading end of the sweeper brush projects beyond the supporting wheel B at that side of the machine, so that the machine may be brought very close to a curb or wall and sweep  
10 the space adjacent thereto.

An actuating shaft  $d$  is supported in a bearing  $d'$ , see Figs. 2, and 3, secured to the bracket  $a$  and in a bearing  $d^2$  on a depending lug or bracket  $d^3$  secured to the main frame  
15 A, said shaft projecting beyond the bearing  $d^2$  to receive thereon loosely the upper end of the supporting arm A<sup>4</sup> herein before described. A beveled gear  $d^4$  is secured to the actuating shaft  $d$  in mesh with a large bevel gear  $d^5$   
20 mounted upon the shaft  $a^3$  of the machine, and connected therewith by a suitable clutch  $d^6$ , the said clutch being thrown into or out of operation by a bent lever  $d^7$  capable of being operated from the forward part of the  
25 frame, so that the rotation of the actuating shaft  $d$  is directly under the control of the driver or person operating the apparatus.

A sprocket or other suitable wheel  $d^8$  is secured to the actuating shaft  $d$ , and a similar  
30 sprocket wheel  $d^9$  is secured to the rearmost end of the shaft  $c$  on the sweeper brush, said sprocket wheels being connected by a suitable link or chain belt  $d^{10}$  whereby when the machine is drawn forward or to the right view-  
35 ing Figs. 1 and 2, and the clutch  $d^6$  is in engagement with the gear wheel  $d^5$ , the rotary movement imparted to the main shaft  $a^3$  of the machine will be transferred to the actuating shaft  $d$  and thence to the sweeper brush,  
40 rotating the same in the direction of the arrow 10 Fig. 1 and at a comparatively slow speed, to thereby sweep up the surface passed over by the machine, the diagonal arrangement of the brush with relation to the path  
45 of movement of the machine collecting and carrying the sweepings over to the rearmost end of the sweeper brush and throwing the sweepings so collected against a shield  $e$  suspended from the frame by flexible connections  $e'$ , the forward end of the shield being  
50 rounded as at  $e^2$  to readily surmount slight obstacles, the sweepings delivered against the vertical inner face of this shield being left thereby in a species of windrow as the machine is moved ahead, and the flexible connections  $e'$  permit the shield to move laterally if desired.

Depending arms D and D' are pivotally mounted upon a shaft D<sup>2</sup> to be described, bearings  $f$  being formed at the lower ends of  
60 said arms to receive therein the ends of the shaft  $f'$  of a rotatable loading brush F, the arms being connected by the chains or other flexible connections  $f^2$  to arms  $f^3$  secured to a  
65 rock-shaft  $f^4$  mounted upon the frame A. An actuating lever  $f^5$  pivoted to the frame at  $f^6$  is connected by a link  $f^7$  to an arm  $f^8$  of said

rock-shaft whereby the loading brush F may be raised or lowered.

Viewing Fig. 1, it will be noticed that the  
70 flexible connections  $f^2$  hang slack when the loading brush rests upon the surface to be swept, in order that it may also rest upon said surface whether the same be smooth or irregular.  
75 Were the said connections rigid, such as rods, the loading brush would be lifted from the ground every time the front of the machine descended into a hollow, and in consequence, a portion of the sweepings would not be engaged by the loading brush.  
80

The main shaft  $a^3$  of the machine supports loosely a gear  $g$  adapted to be engaged at times by a suitable clutch  $g'$ , see Fig. 2, to rotate with the said main shaft, the clutch being controlled by an actuating lever  $g^2$ , and  
85 the shaft D<sup>2</sup> supported in suitable bearings on the frame has fast thereon a gear  $g^3$  in engagement with the gear  $g$  and to be rotated thereby, while a sprocket wheel  $g^4$  is secured to the shaft D<sup>2</sup> beyond the frame of the machine. A smaller sprocket wheel  $g^5$  is secured  
90 to the shaft  $f'$  of the loading brush F and said sprockets are connected by link belt or chain  $g^6$ , so that rotation of the shaft D<sup>2</sup> is communicated to the loading brush F to rotate the same in the direction of the arrow  
95 Fig. 1. This loading brush, as best shown in Fig. 2, is located behind and near the rearmost end of the sweeper brush C to load the sweepings into a trailing dust-pan to be described, whence they are conveyed to a suitable receptacle or hopper to be described.  
100

A conveyer or elevator chute G, partially broken out in Fig. 1 and composed of a suitable frame-work, preferably covered with  
105 sheet iron, is rigidly secured to the frame-work A of the machine by suitable bolts 3, best shown in Fig. 3, a shaft  $h$  passing through and having bearings formed for it in the lower part of the conveyer chute, as  
110 clearly shown in Figs. 1 and 2, the said shaft  $h$  extending beyond the conveyer chute for some distance at the rear of the machine, its outer end being supported in a suitable bearing at the lower end of a bracket  $h'$  depend-  
115 ing from the main frame, rotation being transmitted to the shaft  $h$  by a suitable belt  $h^2$  passing over sprocket or other suitable wheels  $h^3$  and  $h^4$  fast on the shafts  $h$  and  $a^3$  respectively.  
120

The conveyer is herein shown as an endless series of connected buckets  $h^5$ , see Fig. 1, passing around an enlarged portion of the shaft  
125  $h$ , within the conveyer chute, and at the upper end over an adjustable roll  $h^6$  having its bearings in sliding blocks  $h^7$ , regulated by an adjusting screw  $h^8$ , whereby slack in the series of conveyer buckets  $h^5$  can be taken up.

The upper end of the conveyer chute G is notched to form a hood G' intumed toward  
130 the center of the machine and having an inclined bottom  $h^9$ , a narrow flap  $h^{10}$  pivoted at  $h^{11}$  to the side of the chute forming a continuation of the bottom  $h^9$  and being adapted to

be turned up when the hopper is raised to empty it, as will be described hereinafter.

A trailing dust-pan H is pivoted at H' to the base of the chute, which latter is open at its rear side adjacent the loading brush F, the vertical sides of the dust-pan H extending below the axis of and quite near the ends of the loading brush, the portion H<sup>2</sup> of the bottom of the pan being independently pivoted at 50 to the vertical sides thereof.

The loading brush F gathers up the sweepings left in a windrow by the sweeper brush C and by its rapid rotation throws the sweepings up over the bottom of the trailing pan, and into the open end of the conveyer chute, to be gathered up and carried by the series of buckets h<sup>5</sup> to the top of the chute and there discharged through the hood G'. As the pan is pivoted at H' it is free to rise and fall with the inequalities of the surface being swept, and the independently pivoted portion H<sup>2</sup> of the bottom of said pan will yield somewhat should the machine be pushed backward for any reason, thus obviating any possibility of breakage.

In order to collect the sweepings in a convenient receptacle as they are delivered from the hood G', I have provided a hopper K having at its front and rear sides trunnions k, to which are pivotally connected supporting arms k', the other ends of the arms loosely embracing a shaft k<sup>2</sup> supported in bearings on brackets k<sup>3</sup> extended upwardly from the main frame A, said shaft having fast thereon at one end preferably, and as herein shown the front, a gear k<sup>4</sup> in engagement with a smaller gear k<sup>5</sup> on a crank shaft k<sup>6</sup> and rotated by a suitable crank k<sup>7</sup>, retrograde movement of the crank shaft being prevented by the pawl and ratchet mechanism 3 and 4, of any usual construction.

The hopper K is pivotally supported on its trunnions k so that it can be tipped upon them as a center and it can also be raised on the supporting arms k' to a position above the wheels B of the machine, as shown in dotted lines Fig. 3, by mechanism to be described so that it may be tipped on its trunnions to be emptied. When in its normal full line position, the pivoted apron h<sup>10</sup> rests upon the top of and projects slightly into the hopper, so that the sweepings will readily pass from the hood G' to the hopper.

Tracks m are secured to the cross braces A' and A<sup>2</sup> and to the brackets k<sup>3</sup>, to receive thereupon rotatable rolls m' mounted upon suitable studs m<sup>2</sup> secured to the lower ends of links m<sup>3</sup> loosely surrounding the trunnions k of the hopper; and to an ear m<sup>4</sup> secured to or forming a part of each link m<sup>3</sup> I have secured an actuator, herein shown as an endless belt or chain m<sup>5</sup> passing over guides m<sup>6</sup> and m<sup>7</sup>, secured to the braces A', A<sup>2</sup>, and to the tracks m respectively, the belt or chain also passing over a suitable sprocket or other wheel m<sup>8</sup> fast on the shaft k<sup>2</sup>.

The upper ends of the tracks m are up-

turned or hook-shaped as at m<sup>x</sup> to form limiting stops for the rolls m<sup>2</sup> when they have reached their dotted line position Fig. 3.

When the hopper is full of the sweepings, collected and conveyed thereto as hereinbefore described, the machine is preferably stopped, and the crank arm k<sup>7</sup> is rotated until the rotation of the shaft k<sup>2</sup> and the consequent movement given thereby to the actuator m<sup>5</sup> causes the rolls m<sup>2</sup> to rise along the tracks m into the dotted line position shown in Fig. 3, such movement swinging the arms k' and elevating the hopper, when it will be held in such elevated position by the pawl and ratchet 3, 4. A cart or wagon may then be drawn up alongside of the machine and the hopper tipped and its contents dumped therein, after which the pawl and ratchet will be released and the hopper will return to its normal position, the pivoted apron h<sup>10</sup> permitting the movement of the hopper described.

It will be noticed that the various actuating levers or cranks are brought to the forward part of the machine where the driver's seat would be placed, to be readily reached by him without interfering with his other duties.

I claim—

1. In a sweeping machine, a sweeper brush to collect the sweepings, a pivotally supported pan having an independent curved bottom pivoted to the sides of the pan and adapted to rest upon and trail over the surface to be swept just in advance of the loading brush, and a cylindrical loading brush to force the sweepings over said bottom and pan onto a conveyer to convey the sweepings to a suitable receptacle, substantially as described.

2. In a sweeping machine, a sweeper brush, a loading brush, a hopper for the sweepings, and swinging arms to which the hopper is pivoted, combined with actuating mechanism connected to and to raise the hopper and swing the arms, to thereby move the hopper to abnormal elevated position that it may be turned upon its pivots to discharge its contents, and a conveyer to convey the sweepings thereto from the loading brush, substantially as described.

3. In a sweeping machine, a sweeper brush, a loading brush, a hopper, supporting arms pivoted to the hopper and to the machine, actuating mechanism connected to and to raise the hopper and turn said arms, to thereby elevate and carry the hopper to one side of the machine into position to be emptied, and a locking device for the actuating mechanism, combined with a conveyer to convey the sweepings from the loading brush to the hopper, and a hinged flap normally projecting from the conveyer chute over the hopper, upward movement of the latter turning the flap out of its path, substantially as described.

4. In a sweeping machine, a sweeping and a loading brush, and a conveyer to convey the sweepings from the loading brush to the

hopper, combined with a hopper, swinging  
arms to which it is pivoted, fixed inclined  
tracks, rolls pivotally connected by links to  
the hopper and adapted to move along said  
5 tracks, and actuating mechanism connected  
to and to move the rolls upon the tracks to  
raise the hopper and swing the arms, substan-  
tially as described.

In testimony whereof I have signed my  
name to this specification in the presence of  
two subscribing witnesses.

WM. L. TOBEY.

Witnesses:

GEO. W. GREGORY,  
JOHN C. EDWARDS.