

Published:

- *with international search report (Art. 21(3))*
- *before the expiration of the time limit for amending the claims and to be republished in the event of receipt of amendments (Rule 48.2(h))*

ROTOR AND PUMP

Technical field of the invention

5 The present invention relates to a rotor for a pump. In particular the present invention relates to a positive displacement pump which is capable of moving and grinding inhomogeneous materials.

10 Background of the invention

Positive displacement pumps, like rotary pumps or lobe pumps are traditionally used in a variety of industries, including pulp and paper, chemical, food, beverage, pharmaceutical, and biotechnology. They are popular in these diverse industries because they offer superb sanitary qualities, high efficiency, reliability, corrosion resistance and good clean-in-place
15 and steam-in-place (CIP/SIP) characteristics.

Lobe pumps are a preferred choice since they handle solids without damaging the product. Furthermore, the particle size pumped can be much larger in lobe pumps than in other positive displacement pumps.

20

In operation, the material to be pumped, comprising small and/or large particles, is allowed to move around the interior wall of the pumping chamber of the pump where the rotors are located. The rotors comprise impellers that provides the movement of the material and the rotor may comprise a single-impeller, a double-impeller, a tri-impeller or
25 a multiple-impeller. Traditionally the lobe pump is provided with two identical rotors with double-impeller, secured substantially perpendicular to each other. If the number of impellers are different from a double-impellers the angle between the rotors are different. The two rotors are placed close to each other and close to the interior wall of the pumping chamber, but without the rotors touching either each other or the interior wall of the
30 pumping chamber.

As the rotor rotates, the impeller creates an expanding volume on the inlet side of the pump. The material to be pumped moves into this cavity. Rotation of the impeller past the inlet port creates enclosed volumes of material between the rotors and the wall of the
35 pumping chamber.

The material to be pumped moves around the wall of the pumping chamber in these enclosed volumes between the rotor and the wall of the pumping chamber from the inlet to the outlet of the pump, without having the material does to pass between the rotors.

- 5 Continued pumping forces the pumped material to move out through the outlet of the pump and the material may be feed for further processing.

The problem with the traditional available lobe pumps is that they provides no shredding or grinding effect on the particles or solid parts of the material and inhomogeneous material
10 to be pumped.

DK 2012 00207 describes a displacement pump consists of an oval housing on a foot with a rectangular inlet and outlet opening. The displacement pump comprises two identical and symmetrical rotors having a material moving cavity, which has both a leading cutting edge
15 and a tailing cutting edge for shredding and grinding the particles or solid parts of the material and inhomogeneous material to be pumped.

The problem with the devices capable of pumping and shredding/grinding the particles or solid parts of the material and inhomogeneous material to be pumped, such as the pump
20 described in DK 2012 00207, is that the particles and the solid parts may become entrapped between the two rotors and between the rotors and the wall of the pumping chamber, resulting in increased friction of the rotors and the pump, a need for higher energy input to provide sufficient pumping effect and resulting in an increased wear of the rotors and the pump.

25

Hence, an improved rotor and pump would be advantageous, and in particular an improved rotor and pump which avoid or reduce the incidence of having particles entrapped between the rotors; which has a reduced friction of the rotors and the pump; which is more efficient; which has reduced maintenance costs; and which has reduced
30 wear, and a pump that may operate dry without damaging the rotor and/or the pump.

Summary of the invention

Thus, an object of the present invention relates to a rotor and a rotary pump comprising
35 the rotor which is capable of pumping and grinding inhomogeneous materials.

In particular, it is an object of the present invention to provide a rotor and a pump that solves the above mentioned problems of the prior art with having particles entrapped

between the rotors; which has a reduced friction of the rotors and the pump; which is more efficient; which has reduced maintenance costs; and which has reduced wear, and a pump that may operate dry without damaging the rotor and/or the pump.

- 5 Thus, one aspect of the invention relates to a rotor for a pump comprising an asymmetrical structure, wherein the rotor comprises at least one cutting edge and at least one rounded edge.

Another aspect of the present invention relates to a pump, comprising one or more rotors
10 according to the present invention.

Yet an aspect of the present invention relates to a method for producing a digestible material, from a material selected from feather; hair; hoof; nails, bone, meat or a combination hereof, said method comprising the steps of:

15

(i) moving and grinding the material to a hydrolyzer using a grinding pump;

(ii) hydrolyzing the grinded material providing a hydrolyzed material; and

20

(iii) drying the resulting hydrolyzed material providing the digestible material.

Still another aspect of the present invention relates to a use of a pump according to the present invention in moving and grinding a rendering material.

25

Brief description of the figures

Figure 1 shows a front view of the rotor (1) according to the present invention with the cutting edges (2) and the rounded edges (3);

30

Figure 2 shows a sideview of the rotor (1) according to the present invention with the cutting edges (2) and the rounded edges (3);

Figure 3 shows a pump (10) having the rotors (not shown) mounted inside the closed
35 pumping chamber;

Figure 4 shows a pump (10) with the outlet (12) and having the rotors (1) mounted inside the pumping chamber; and

Figure 5 shows a pump (10) having the rotors (1) mounted inside the pumping chamber.

5 The present invention will now be described in more detail in the following.

Detailed description of the invention

Accordingly, the present inventors found a problem in the presently provided rotors and pumps as the friction between the rotors quickly was increased as particles became
10 entrapped between the rotors during rotation, whereby the hard particles wears the rotors and additional energy must be supplied in order to provide the desired pumping effect. The increased wear also resulting in frequent process-shutdowns and frequent replacement of rotors.

15 The inventors surprisingly found that a specialised design or structure of the rotor was solving this problem and where particles are allowed to escape the space between the rotors and does not becomes entrapped and squeezed by the rotors and wear is significantly reduced.

20 A preferred embodiment of the present invention relates to a rotor comprising an asymmetrical structure for a pump, wherein the rotor comprises at least one cutting edge and at least one rounded edge.

In an embodiment of the present invention the radius from the centre of the rotor to the
25 cutting edge is substantially the same as the radius from the centre of the rotor to the rounded edge.

The term "substantially the same" in respect of the difference between the radius of the cutting edge relative to the rounded edge (or vice versa) relates to a difference of 5% or
30 less; such as 4% or less; e.g. 3% or less; such as 2% or less; e.g. 1% or less; such as 0,5% or less; e.g. 0.1% or less; such as 0.05% or less; e.g. 0.01% or less; such as 0.001% or less; e.g. 0%.

In an embodiment of the present invention the rotor may be a single-impeller; a double-impeller; a tri-impeller; or a multiple-impeller. In the present context the impeller may be
35 the part of the rotor that moves the material from the inlet of a pump to the outlet of the pump. A rotor comprising a single-impeller has only one part moving the material through the pump; a rotor having double-impeller has two parts moving the material; a rotor

having a tri-impeller has three parts moving the material; and a rotor having multiple-impeller has multiple parts moving the material.

The at least one cutting edge of the rotor may preferably be a sharpened edge that
5 together with a sharpened edge on the inlet of the pump is responsible for shredding and grinding of the material to be pumped.

The cutting edge of the rotor may be provided with a coating in order to make the cutting more efficient and capable of cutting hard materials. Preferably the coating further hardens
10 the at least one cutting edge. The cutting edge may be provided with a hard coating, preferably a hard metal coating, such as steel, preferably stainless steel.

The shredding and grinding of the material to be pumped by introducing further cutting edges. In an embodiment of the present invention the rotor comprises at least two cutting
15 edges and at least two rounded edges; such as at least 3 cutting edges and at least 3 rounded edges; e.g. at least 4 cutting edges and at least 4 rounded edges; such as at least 4 cutting edges and at least 4 rounded edges.

In order to provide the cutting effect of the cutting edge the rotor may be placed correctly
20 in the pump and provided with the correct rotation.

Upon rotation the at least one cutting edge (2) may be a leading edge and the at least one rounded edge (3) may be a trailing edge.

25 The rotor according to the present invention may be designed from a first circular element where a material-moving cavity is provided in the first circular element. The material-moving cavity may be provided by a cutting in the first circular element or the design of the rotor including the material-moving cavity may be moulded.

30 In an embodiment of the present invention the rotor comprising a first circular element comprising one or more cut-outs providing at least one material-moving cavity, having in one end a cutting edge and in another end a rounded edge.

The first circular element may have a convex surface. Preferably, the convex surface of the
35 rotor makes a perfect fit with the concave wall of the pumping surface of a pump, such as a positive displacement pump, e.g. a lobe pump or a rotary lobe pump. In the present context the term "perfect fit" relates to an improved mechanical engagement of the first circular element with the circular wall of the pumping chamber. The perfect fit of the first circular element with the circular wall of the pumping chamber assist in an improved

pumping effect and a reduced tendency for particles and solid parts pumped to become entrapped between the rotors and the wall of the pumping chamber, which entrapment may result in increased friction of the rotors and the pump, a need for higher energy input to provide sufficient pumping effect, as well as an increased wear of the rotors and
5 the pump. Thus, the rotors of the present invention may provide a decreased friction, a reduced power consumption and a decreased wear of the rotors.

In a further embodiment of the present invention the rotor may comprise at least one material moving cavity, such as at least two material moving cavities, e.g. at least three
10 material moving cavities, such as at least 3 material moving cavities, e.g. at least 4 material moving cavities. Preferably, the rotor comprises 2 material moving cavities.

The size and/or structure of the at least one material-moving cavity may be defined by a second circular element; a first concave recess; and a second concave recess. The second
15 circular element may be determined by the depth of the material-moving cavity and may vary depending on the material to be pumped.

The intersection between the first concave recess and the first circular element, in particular the outer edge of the first circular element, may provide the at least one cutting
20 edge. The form of the first concave recess may be changed depending on the type, complexity and amount of the material to be pumped and the degree of shredding/grinding desired.

The intersection between the second concave recess and the first circular element, in particular the outer edge of the first circular element, provides the at least one rounded
25 edge. The form of the second concave recess may be changed depending on the type and complexity of the material to be pumped in order to avoid hard particles gets stock between the two rotors in a pump and hence reduce the friction and wear of the rotors.

30 In an embodiment of the present invention the first circular element comprises a radius in the range of 5-50 cm, such as in the range of 7-40 cm, e.g. in the range of 10-30 cm, such as in the range of 12-25 cm, e.g. in the range of 15-20 cm, such as about 17 cm.

In another embodiment of the present invention the second circular element comprises a
35 radius in the range of 1-20 cm, such as in the range of 3-15 cm, e.g. in the range of 5-12 cm, such as in the range of 6-10 cm, e.g. about 8 cm.

Preferably, the first circular element comprises a radius in the range of 5-50 cm, such as in the range of 7-40 cm, e.g. in the range of 10-30 cm, such as in the range of 12-25 cm,

e.g. in the range of 15-20 cm, such as about 17 cm; and the second circular element comprises a radius in the range of 1-20 cm, such as in the range of 3-15 cm, e.g. in the range of 5-12 cm, such as in the range of 6-10 cm, e.g. about 8 cm.

5 In an embodiment of the present invention the radius of a second circular element may be between 20-80% of the radius of a first circular element, providing the material-moving cavity, such as between 25-70%, e.g. between 30-60%, such as between 40-55%, e.g. between 45-50%.

10 In a further embodiment of the present invention the rotor may have a width which is in the range of 1-50 cm, such as in the range of 5-45 cm, e.g. in the range of 10-40 cm, such as in the range of 15-35 cm, e.g. in the range of 20-30 cm, such as about 25 cm.

The rotor may be prepared from a metal material; a plastic material; a ceramic material
15 and/or a combination hereof.

The rotor may preferably be prepared from a single material, either by cutting or moulding.

20 A further preferred embodiment of the present invention relates to a pump comprising one or more rotors according to the present invention.

Preferably, the pump according to the present invention comprises two rotors according to the present invention.

25

The pump may preferably be a positive displacement pump, even more preferably, the positive displacement pump may be a lobe pump or a rotary lobe pump.

The pump according to the present invention comprises an inlet for feeding material to the
30 pump and an outlet for taken out the pumped material or for feeding the material to a further processing device.

A further processing device may be a hydrolyser; a decanter; dryer; an air turbulence mill; or the like.

35

In an embodiment of the present invention the pump may comprise a square or rectangular shaped inlet and/or a square or rectangular shaped outlet.

In order to improve the flow through the pump the inlet of the pump and/or the outlet of the pump have substantially the same width as the width of the rotor. In the present context the term "substantially the same" relates to an inlet and/or an outlet which is/are 10% smaller or less relative to the width of the rotor; such as 8% smaller or less; e.g. 6% smaller or less; such as 4% smaller or less; e.g. 2% smaller or less; such as 4% smaller or less; e.g. has the same width as the rotor.

In an embodiment of the present invention the outlet has the same, or substantially the same, width as is the inlet.

10

In order to avoid friction between the rotor and the pumping chamber the rotor may have a width which is 0.1-5 cm smaller than the internal width of a pumping chamber of a pump.

15 In an embodiment of the present invention the width of the inlet and/or the width of the outlet is between 25-98% of the width of the rotor, such as between 40-94%, e.g. between 50-96%, such as between 60-92%, e.g. between 70-90%, such as in the range of 75-85%.

20 In order to improve and support the shedding/grinding effect of the pump the inlet may be provided with a sharpened edge. The sharpened edge may be provided for cutting the particles and solid parts of the material into smaller pieces (this being done in combination with the cutting edge on the rotor).

25 The rotors are mounted in the pump for rotating in opposite directions.

In an embodiment of the present invention a pair of identical rotors are invertible mounted on rotating shafts in the pumping chamber of the pump. The rotating shafts preferably rotates in opposite directions.

30 The pump is suitable for pumping a material comprising particles and/or solid parts.

Preferably, the material to be pumped comprises particles and/or solid parts having a particle sizes above 0.5 mm, such as above 1 mm, e.g. above 5 mm, such as above 1 cm, e.g. above 3 cm, such as above 5 cm, e.g. above 10 cm, such as in the range of 0.50 mm-40 cm; e.g. in the range of 1-35 cm; such as 5-30 cm; e.g. in the range of 10-25 cm; such as 15-20 cm.

In an embodiment of the present invention the material may be in the form of a liquid, a slurry, a paste or a dough. Preferably, the material may be a rendering material.

Preferably, the rendering material may have a moisture content of 15% (w/w) or more, such as 20 (w/w) or more, e.g. 25% (w/w), such as 30 (w/w) or more, e.g. 40% (w/w), such as 50 (w/w) or more, e.g. 60% (w/w), such as 70 (w/w) or more, e.g. in the range of 5 15-70% (w/w), such as in the range of 20-60% (w/w), e.g. in the range of 25-55% (w/w), such as in the range of 30-50% (w/w), e.g. in the range of 40-45% (w/w).

In a further embodiment of the present invention the rendering material may be a feather rendering material; a meat rendering material; a blood rendering material; a bone rendering material; an offal rendering material; a hair rendering material; or any 10 combination hereof.

The rotors are mounted in a pump, such as a displacement pump, e.g. a lobe pump of a rotary pump, with two opposite rotating rotors. Both rotors are provided with a cutting 15 edge on the front, in a leading edge, relative to the rotation direction. On the back of both rotors there is a rounding edge (a slip / a tailing edge, relative to the rotation direction) which ensures reduced resistance or friction in the pump. Possibly, materials caught during the rotation of the two rotors are released on the tailing edge of the rotor.

20 The two rotors may preferably be made of two solid pieces. The inlet of the pump is also provided with a cutting edge, throughout the width. The rotors and the pumping chamber are fitted to each other and there is only a very small space where the two rotors pass the wall of the pumping chamber. Thereby, the cutting effect is obtained from the cutting edge of the rotor and the cutting edge of the inlet which gives the shredding and grinding of the 25 material.

When moving inhomogeneous media containing particles or solid parts, for example: crude sludge; chopped animal & slaughtered waste like animal offal; bones and blood; feathers, hoof, nails hair; fish and fish waste and the like.

30

The rotor and the pump according to the present invention provides a design which makes it possible to precisely subdivide, chop and pump even very inhomogeneous materials, while at the same time reducing the power considerably.

35 The pump is designed so that inlet and outlet have substantially the same width as the rotors mounted inside the pump. This may assist larger particles to be sucked in and pressed out of the pump. The invention minimizes the power needed. It reduces maintenance to a minimum due to the few internal parts and the low friction. Often a

breakdown may be required for the materials to pass through the pump, and this effect may be provided by the pump according to the present invention.

The rotor and the pump differentiate from the prior art by combining the cutting effect on
5 the two rotors with the rounding / slip of the asymmetric rotors on the tailing edge.

The pump housing may preferably be constructed symmetrically while the two rotors according to the present invention are constructed asymmetrical, and it may be possible to pump in the opposite direction with the same pump installation by reversing the two rotors
10 mounted in the pump.

Since internal friction is reduced by the present invention the pump may withstand dry running. Also, a reduced power may be required for pumping a given amount of media at a particular pressure. The rounding edge ensures that particles or excess material can
15 escape without wearing the rotors or the pump. Depending on the nature of the medium, the size of the rounding radius and/or shape can be varied. This ensures minimal resistance between the medium being pumped and the pump rotors.

In a preferred embodiment of the present invention the pump may be used in moving and
20 grinding a rendering material.

Preferably, the rendering material relates to a feather rendering material; a meat rendering material; a blood rendering material; a bone rendering material; an offal rendering material; a hair rendering material; or a combination hereof.
25

Another preferred embodiment of the present invention relates to a method for producing a digestible material, from a material selected from feather; hair; hoof; nails, bone, meat or a combination hereof, said method comprising the steps of:

- 30 (i) moving and grinding the material to a hydrolyzer using a grinding pump;
- (ii) hydrolyzing the grinded material providing a hydrolyzed material;
- (iii) drying the resulting hydrolyzed material providing the digestible material.

35

Preferably the pump described in step (i) is a pump according to the present invention.

In a further embodiment of the present invention the hydrolyzing step (ii) may be performed in the presence of water; heat and at a pressure between about 2 bar and about 10 bar.

- 5 In yet an embodiment of the present invention the drying step (iii) may involve drying in a disc dryer at reduced pressure (preferably at a pressure between about 10 and about 500 mbar (abs), preferably between about 100 and about 400 mbar); in a flow of hot air such as a flash dryer, a fluidized bed dryer, ring-type dryer, rotating flash dryers and the like. Preferably, the drying using hot air involves a residence time in the dryer of 2 minutes or
10 less; such as 1 minutes or less; e.g. 30 seconds or less, such as 20 seconds or less; e.g. 10 seconds or less, such as 5 seconds or less.

Further details on how to produce digestible or highly digestible materials are known to the skilled person. Specific examples of producing digestible or highly digestible materials may
15 be as described in EP 2 832 236; EP 3 192 377 and/or EP 3 027 065, which methods are hereby incorporated by reference.

Detailed description of the drawings

- 20 Figures 1 and 2 show the rotor (1) according to the present invention. The rotor (1) may comprise 2 cutting edges (2) for shedding or grinding the material to be pumped. and 2 rounded edges (3). Depending on the application the rotor (1) may comprise further cutting edges (2) and further rounded edges (3), Preferably, the rotor (1) comprises at least two cutting edges (2) and at least two rounded edges (3). The rotor (1) comprises a
25 radius (r_1) from the centre (C) of the rotor to the cutting edge is substantially the same as the radius (r_2) from the centre (C) of the rotor to the rounded edge. Preferably, the radius from the centre (C) of the rotor to the cutting edge is 5% or less than the radius from the centre (C) of the rotor to the rounded edge. In operation the at least one cutting edge (2) may be a leading edge and the at least one rounded edge (3) may be a tailing edge. The
30 rotor may be provided with a first circular element (4) which matches the outer circumference of the rotor (1) illustrated in figure 1 as a dashed line. The first circular element (4) comprising one or more cut-outs providing at least one material-moving cavity (5), having in one end a cutting edge (2) and in another end a rounded edge (3). The at least one material-moving cavity (5) may be defined by a second circular element (6); a
35 first concave recess (7); and a second concave recess (8). The rotor (1) may have several material-moving cavities (5), preferably the rotor (1) according to the present invention comprises 2 material-moving cavities (5). The intersection between the first concave recess (7) and the first circular element (4) provides the at least one cutting edge (2) and the intersection between the second concave recess (8) and the first circular element (4)

provides the at least one rounded edge (3). The first circular element (4) may comprise a radius in the range of 5-50 cm and the second circular element (6) may comprise a radius in the range of 1-20 cm. In order to improve the cutting effect of the rotor of the present invention the cutting edge (2) may be sharpened and/or provided with a hard sharpened coating, e.g. a hard metal coating.

Figures 3 and 4 shows a pump (10) such as a positive displacement pump, e.g. a lobe pump or a rotary lobe pump, comprising a rotor (1) according to the present invention (the rotor (1) has not been shown in figure 3). The pump (10) comprises a square formed outlet (12) and the outlet (12) has the same, or substantially the same, width as is the inlet (11). The pump (10) may be designed so that the inlet (11) and the outlet (12) have substantially the same width as the rotors (1) mounted inside the pump on the rotating shafts (14 and 15) in the pumping chamber (16). Rotation of the rotors (1) in the pumping chamber (16) is controlled by a gearing (17) and a motor (18). The material to be pumped may be material is in the form of a liquid, a slurry or a dough. Preferably, the material to be pumped has a moisture content in the range of 15-70% (w/w). The material is a rendering material, such as a feather rendering material; a meat rendering material; a blood rendering material; a bone rendering material; an offal rendering material; a hair rendering material; or a combination hereof.

20

Figure 5 shows a pump (10) such as a positive displacement pump, e.g. a lobe pump or a rotary lobe pump, comprising a pumping chamber (16) having two rotors (1) mounted inside the pump on rotating shafts (14 and 15) in the pumping chamber (16). Each rotor (1) comprising two cutting edges (2) for shedding or grinding the material to be pumped and two rounded edges (3) allowing particles and material to escape from the space between the two rotors (1). The arrows marked on the rotors (1) demonstrates the rotation direction of the rotors which are substantially perpendicular placed relative to each other. The pump (10) comprises a square formed outlet (12) and the outlet (12) has the same, or substantially the same, width and form as is the inlet (11). The Inlet (11) is further provided with a sharpened edge (13) that together with the cutting edge (2) of the rotor is capable of shedding and grinding the particles and/or solid parts of the material to be pumped. Each rotor (1) provides a material-moving cavity (5) between the second circular element (6); the first concave recess (7); the second concave recess (8) and the wall of the pumping chamber (16a).

35

It should be noted that embodiments and features described in the context of one of the aspects of the present invention also apply to the other aspects of the invention.

All patent and non-patent references cited in the present application, are hereby incorporated by reference in their entirety.

The invention will now be described in further details in the following non-limiting 5 examples.

References

EP 2 832 236

EP 3 192 377

EP 3 027 065

Claims

1. A rotor (1) comprising an asymmetrical structure for a pump, wherein the rotor (1) comprises at least one cutting edge (2) and at least one rounded edge (3).
- 5
2. The rotor (1) according to claim 1, wherein the radius from the centre of the rotor to the cutting edge is substantially the same as the radius from the centre of the rotor to the rounded edge.
- 10
3. The rotor (1) according to anyone of claims 1 or 2, wherein the radius from the centre (C) of the rotor to the cutting edge is 5% or less than the radius from the centre (C) of the rotor to the rounded edge; such as 4% or less; e.g. 3% or less; such as 2% or less; e.g. 1% or less; such as 0,5% or less; e.g. 0.1% or less; such as 0.05% or less; e.g. 0.01% or less; such as 0.001% or less; e.g. 0%.
- 15
4. The rotor (1) according to anyone of claims 1-3, wherein the rotor (1) is a single-impeller; a double-impeller; a tri-impeller; or a multiple-impeller.
5. The rotor (1) according to anyone of the preceding claims, wherein the at least one
- 20 cutting edge (2) is a leading edge and the at least one rounded edge (3) is a tailing edge.
6. The rotor (1) according to anyone of the preceding claims, wherein the rotor (1) comprising a first circular element (4) comprising one or more cut-outs providing at least one material-moving cavity (5), having in one end a cutting edge (2) and in another end a
- 25 rounded edge (3).
7. A pump (10) comprising one or more rotors (1) according to anyone of claims 1-6.
8. The pump (10) according to claim 7, wherein the pump is a positive displacement
- 30 pump, wherein the positive displacement pump is a lobe pump or a rotary lobe pump.
9. The pump (10) according to anyone of claims 7-8, wherein the pump comprises a square or rectangular shaped inlet (11) and/or a square or rectangular shaped outlet (12), wherein the inlet is provided with a sharpened edge (13).
- 35
10. The pump (10) according to anyone of claims 7-9, wherein the material is a rendering material.

11. A method for producing a digestible material, from a material selected from feather; hair; hoof; nails, bone, meat or a combination hereof, said method comprising the steps of:

- 5 (iv) moving and grinding the material to a hydrolyzer using a grinding pump, preferably the pump is a pump according to anyone of claims 7-10;
- (v) hydrolyzing the grinded material providing a hydrolyzed material;
- 10 (vi) drying the resulting hydrolyzed material providing the digestible material.

12. Use of a pump according to anyone of claims 7-10, in moving and grinding a rendering material.

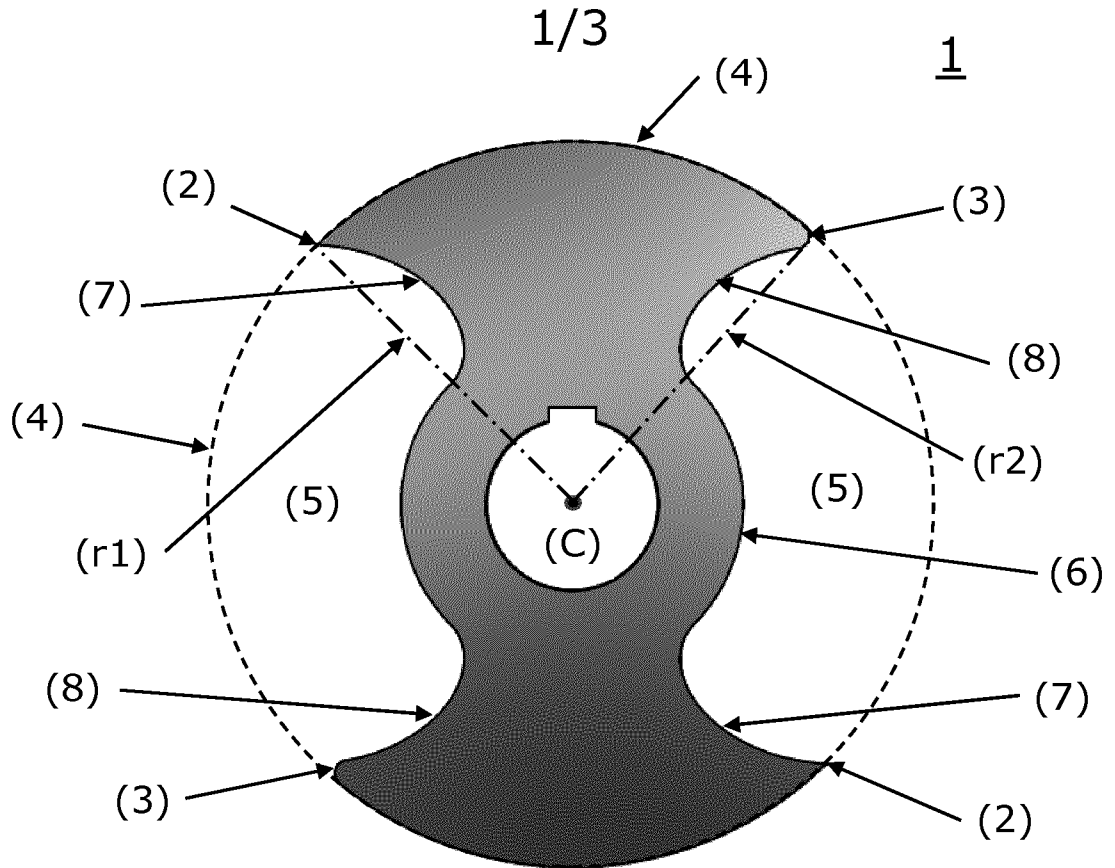

Fig. 1

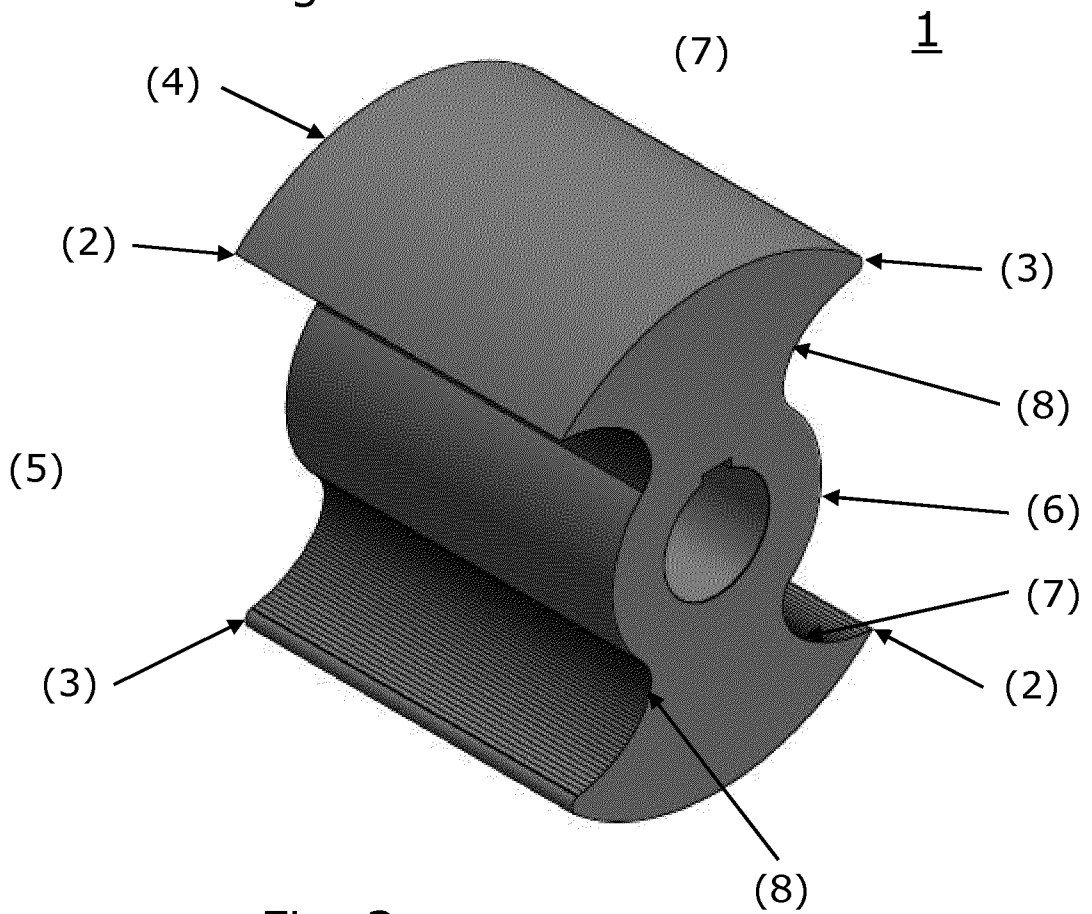

Fig. 2

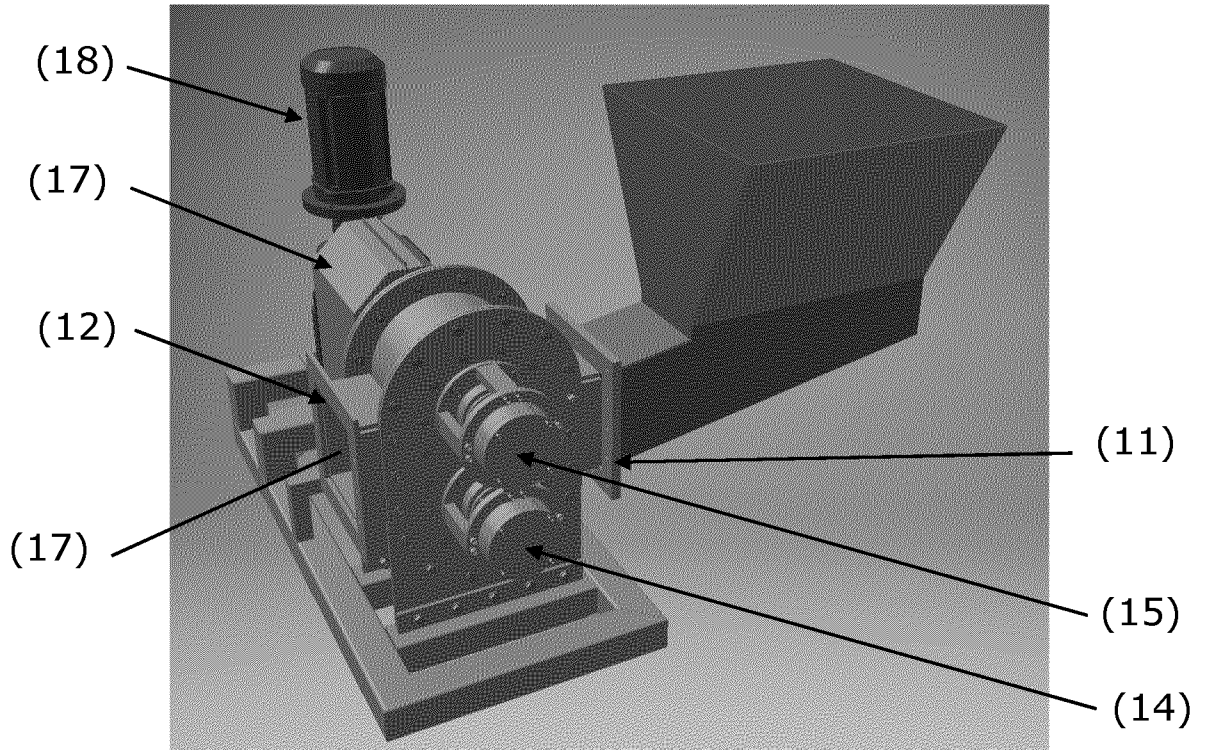

Fig. 3

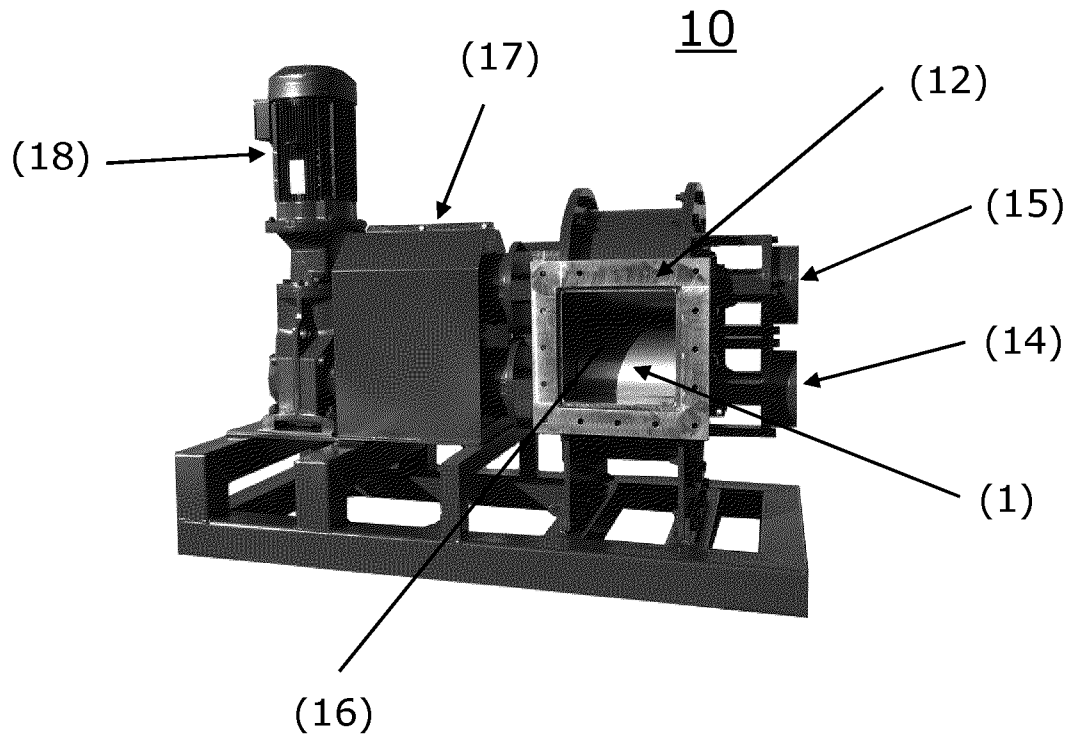

Fig. 4

3/3

10

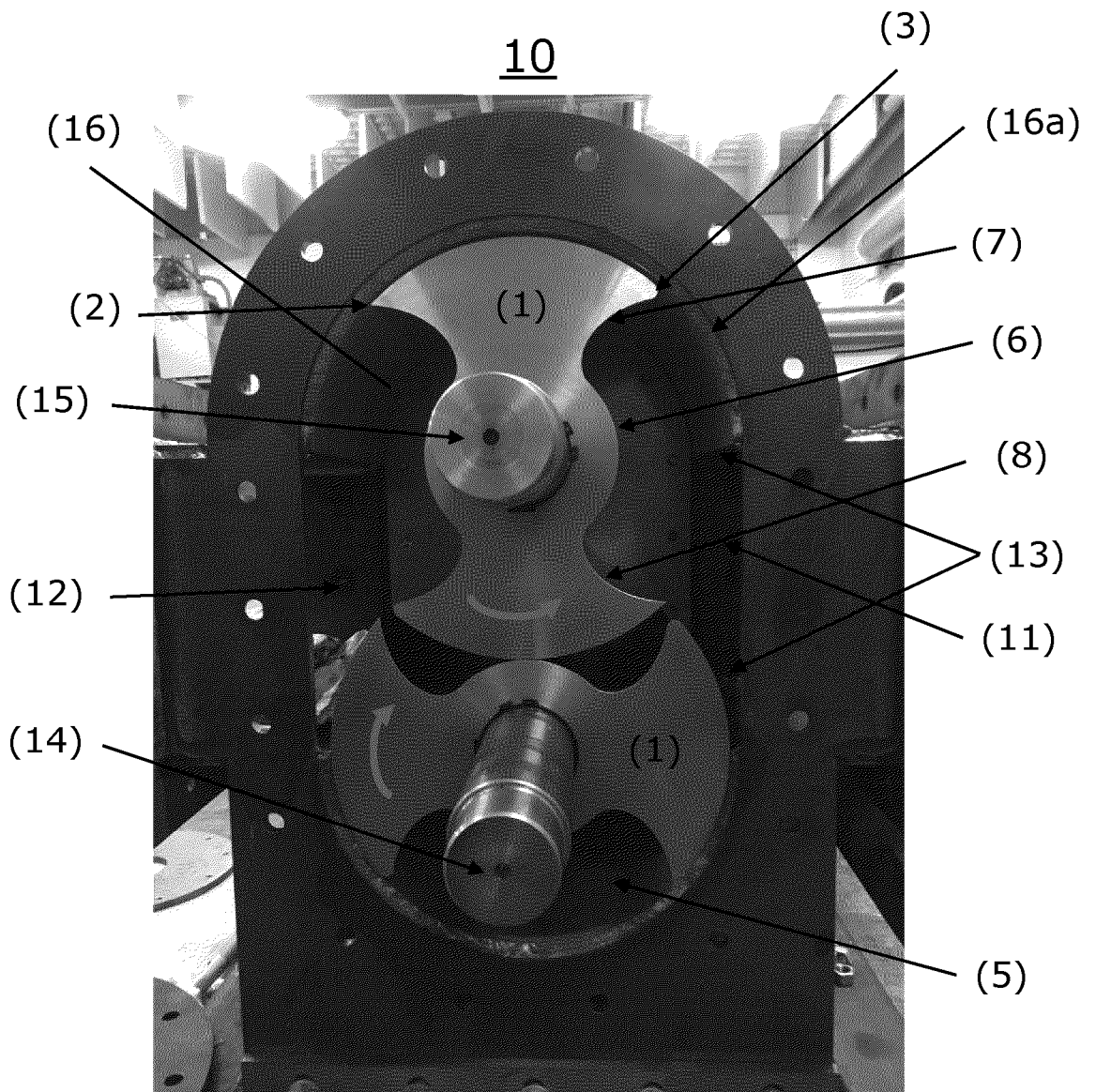

Fig. 5

INTERNATIONAL SEARCH REPORT

International application No
PCT/EP2020/065360

A. CLASSIFICATION OF SUBJECT MATTER
INV. F04C2/12 F04C13/00 F04C15/06
ADD.
According to International Patent Classification (IPC) or to both national classification and IPC

B. FIELDS SEARCHED
Minimum documentation searched (classification system followed by classification symbols)
F04C F01C
Documentation searched other than minimum documentation to the extent that such documents are included in the fields searched

Electronic data base consulted during the international search (name of data base and, where practicable, search terms used)
EPO-Internal, WPI Data

C. DOCUMENTS CONSIDERED TO BE RELEVANT

Category*	Citation of document, with indication, where appropriate, of the relevant passages	Relevant to claim No.
X	GB 1 405 955 A (RANSBURG CORP) 10 September 1975 (1975-09-10) the whole document figures 5,8,9,12 page 4, line 59 - line 82 -----	1-10,12
X	US 4 984 975 A (THOMPSON GEORGE A [US]) 15 January 1991 (1991-01-15) the whole document figures 1,3 claims 1-3 column 1, line 42 - line 60 -----	1-10,12
X	DE 100 30 957 C1 (BOERGER GMBH [DE]) 14 February 2002 (2002-02-14) the whole document figures 1,2 paragraph [0005] - paragraph [0007] paragraph [0035] - paragraph [0039] -----	1-10,12

Further documents are listed in the continuation of Box C.

See patent family annex.

* Special categories of cited documents :

- "A" document defining the general state of the art which is not considered to be of particular relevance
- "E" earlier application or patent but published on or after the international filing date
- "L" document which may throw doubts on priority claim(s) or which is cited to establish the publication date of another citation or other special reason (as specified)
- "O" document referring to an oral disclosure, use, exhibition or other means
- "P" document published prior to the international filing date but later than the priority date claimed

- "T" later document published after the international filing date or priority date and not in conflict with the application but cited to understand the principle or theory underlying the invention
- "X" document of particular relevance; the claimed invention cannot be considered novel or cannot be considered to involve an inventive step when the document is taken alone
- "Y" document of particular relevance; the claimed invention cannot be considered to involve an inventive step when the document is combined with one or more other such documents, such combination being obvious to a person skilled in the art
- "&" document member of the same patent family

Date of the actual completion of the international search 18 August 2020	Date of mailing of the international search report 20/10/2020
---	--

Name and mailing address of the ISA/ European Patent Office, P.B. 5818 Patentlaan 2 NL - 2280 HV Rijswijk Tel. (+31-70) 340-2040, Fax: (+31-70) 340-3016	Authorized officer Sbresny, Heiko
--	--

INTERNATIONAL SEARCH REPORT

International application No.
PCT/EP2020/065360

Box No. II Observations where certain claims were found unsearchable (Continuation of item 2 of first sheet)

This international search report has not been established in respect of certain claims under Article 17(2)(a) for the following reasons:

1. Claims Nos.:
because they relate to subject matter not required to be searched by this Authority, namely:

2. Claims Nos.:
because they relate to parts of the international application that do not comply with the prescribed requirements to such an extent that no meaningful international search can be carried out, specifically:

3. Claims Nos.:
because they are dependent claims and are not drafted in accordance with the second and third sentences of Rule 6.4(a).

Box No. III Observations where unity of invention is lacking (Continuation of item 3 of first sheet)

This International Searching Authority found multiple inventions in this international application, as follows:

see additional sheet

1. As all required additional search fees were timely paid by the applicant, this international search report covers all searchable claims.

2. As all searchable claims could be searched without effort justifying an additional fees, this Authority did not invite payment of additional fees.

3. As only some of the required additional search fees were timely paid by the applicant, this international search report covers only those claims for which fees were paid, specifically claims Nos.:

4. No required additional search fees were timely paid by the applicant. Consequently, this international search report is restricted to the invention first mentioned in the claims; it is covered by claims Nos.:
1-10, 12

Remark on Protest

- The additional search fees were accompanied by the applicant's protest and, where applicable, the payment of a protest fee.
- The additional search fees were accompanied by the applicant's protest but the applicable protest fee was not paid within the time limit specified in the invitation.
- No protest accompanied the payment of additional search fees.

FURTHER INFORMATION CONTINUED FROM PCT/ISA/ 210

This International Searching Authority found multiple (groups of) inventions in this international application, as follows:

1. claims: 1-10, 12

Rotor for a pump and pump comprising such a rotor, wherein the rotor has at least one cutting edge in order to provide for grinding of material.

2. claim: 11

Method for producing a digestible material applying a grinding pump for moving and grinding.

INTERNATIONAL SEARCH REPORT

Information on patent family members

International application No

PCT/EP2020/065360

Patent document cited in search report	Publication date	Patent family member(s)	Publication date
GB 1405955	A	10-09-1975	AU 459524 B2 27-03-1975
			BE 790061 A 01-02-1973
			CA 971424 A 22-07-1975
			DE 2250347 A1 19-04-1973
			FR 2203441 A5 10-05-1974
			GB 1405955 A 10-09-1975
			SE 389378 B 01-11-1976

US 4984975	A	15-01-1991	NONE

DE 10030957	C1	14-02-2002	NONE
