

Feb. 2, 1943.

F. P. MILLER

2,309,657

ROTARY CUTTER

Original Filed Nov. 16, 1937

2 Sheets-Sheet 1

*Fig. 1.*

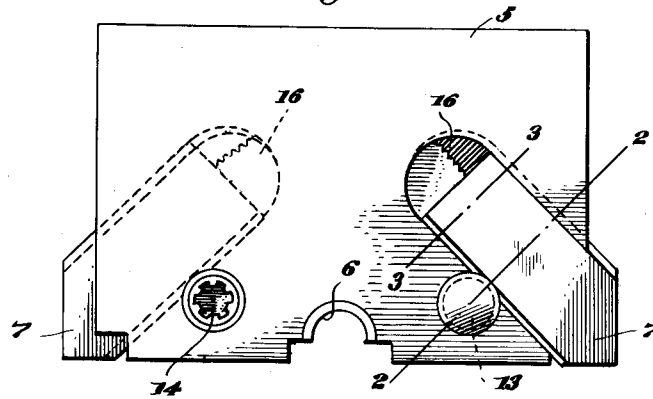

*Fig. 2.*

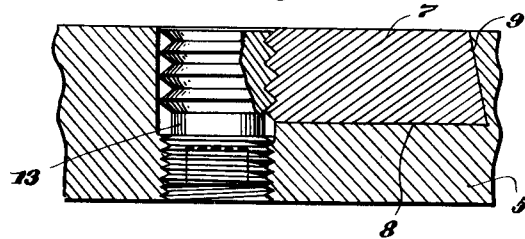

*Fig. 3.*

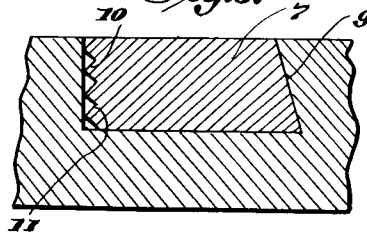

*Fig. 4.*

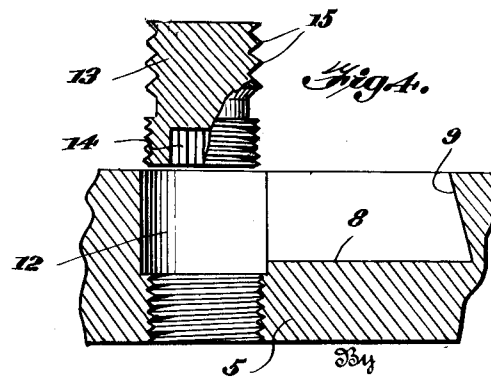

Inventor  
FRANK P. MILLER

*E. F. Salter*

Attorney

Feb. 2, 1943.

F. P. MILLER

2,309,657

ROTARY CUTTER

Original Filed Nov. 16, 1937

2 Sheets-Sheet 2

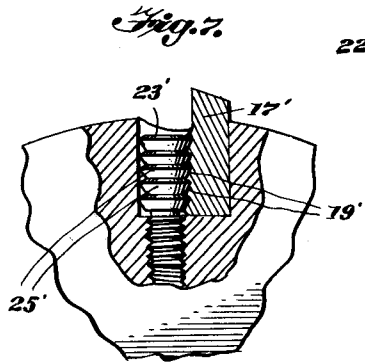
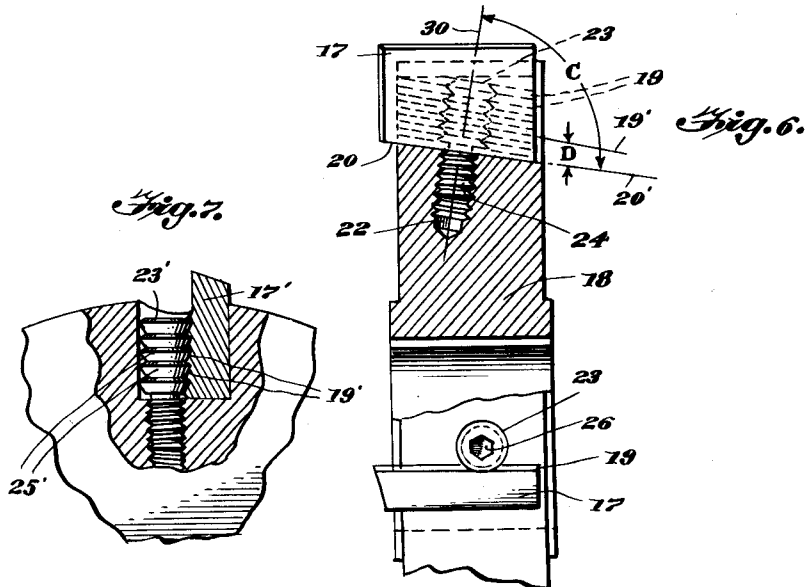
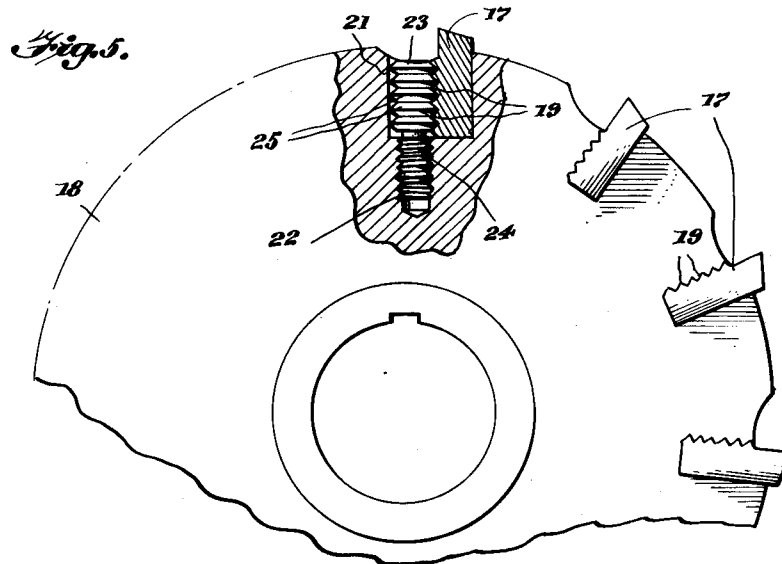

Inventor  
FRANK P. MILLER

*E. F. Salter*

Attorney

334

# UNITED STATES PATENT OFFICE

2,309,657

## ROTARY CUTTER

Frank P. Miller, Meadville, Pa.

Original application November 16, 1937, Serial No. 174,879. Divided and this application February 12, 1940, Serial No. 318,585

6 Claims. (Cl. 29—105)

This invention relates to rotary cutters equipped with inserted blades, and particularly to means for locking and holding the blades in positions of adjustment. This application is a continuation in part of my prior application Serial No. 174,879, filed November 16, 1937, and as to all common subject matter is a division thereof.

An object of the invention is to provide an improved blade locking means having a wedge member in threaded engagement with the body of a tool or holder in which a blade is inserted, and which is provided with one or more conic bearing surfaces rotatably meshed with serrations on the blade to exert a wedging action thereagainst as the member is moved on the axis of said conic surfaces by adjustment of its threaded connection with the tool or holder.

Another object is to provide a blade lock having a rotatable locking member adjustably engageable with the body of a tool or holder for movement on the axis of rotation of the member, and having annular serrations meshed with complementary blade serrations which occupy planes inclined with respect to the axis of rotation of the lock member, whereby the lock member serves both as a wedge and backing screw for its associated blade.

A further object is to provide, in an inserted blade cutter, means for locking a blade against retrograde movement imparted by thrust when engaged with work, with the means being arranged for operation independently of its movement arresting function to wedge an associated blade firmly in its position of adjustment in a tool or holder.

Other objects will be readily apparent to those skilled in the art.

In the accompanying drawings:

Figure 1 is a plan view of a cutter block for use in rotary cutters of the boring bar type, having blades anchored therein in accordance with the invention.

Figure 2 is a section taken on the line 2—2 of Figure 1.

Figure 3 is a section taken on the line 3—3 of Figure 1.

Figure 4 is a section as in Figure 2, but showing the blade locking member removed from its socket, and with the blade removed.

Figure 5 is a front elevation, partly in section, of a rotary cutter equipped with the blade locking means of the invention.

Figure 6 is a fragmentary radial section of the cutter, partly in elevation, illustrating the detail of the blade mounting and its locking means.

Figure 7 is a fragmentary section similar to that of Figure 5, but illustrating an alternative embodiment of blade locking means.

In detail, the embodiment of the invention shown in Figures 1—4 comprises a cutter block 5 having a centering recess 6 in its forward straight edge and designed to mount a pair of substantially diagonally disposed cutter blades 7. Each blade is received in a slot 8 dovetailed as at 9 along one side only, the other side wall of the slot being perpendicular to the flat bottom of the slot. That side of the blade which engages the perpendicular slot wall is formed with a series of longitudinally extending, shallow, parallel serrations 10 having inclined faces meeting at obtuse angles in the bottoms of intervening grooves 11.

Contiguous to each blade slot 8, the body of the block is provided from one face to the other with a cylindrical bore 12 receiving a locking screw member 13 which has its leading end threaded into the lower end of the bore and with a left-hand thread. The leading end is formed with an axial tool socket 14.

The unthreaded portion of each bore 12 opens through the perpendicular wall of the blade slot and extends somewhat thereinto. At its trailing end portion the shank of the locking screw 13 is formed with a series of parallel annular ridges 15 which correspond in cross section to the grooves in the adjacent side of the blade.

It is apparent from Figure 2 that when the locking screw is given a right-hand turn its leading end will be advanced in its receiving bore and, in consequence, the leading inclined sides of the ridges 15 will bear against the adjacent inclined faces of the blade serrations 10, forcing the blade downwardly into a firm seat on the bottom of its slot and at the same time forcing the blade laterally into engagement with the dovetailed wall 9 of the slot. This action provides a compound wedging movement that securely locks the blades in place, resulting from the helical angle of the thread plus the angle of contact between angular grooves of the locking screw and the blade serrations.

The block 5 is further provided with backing thrust screws 16, as in my prior Patent No. 2,076,663 granted April 13, 1937.

Figures 5 and 6 illustrate an embodiment of the invention in which the cutter blades 17 are inserted in radial receiving slots provided in the body of a rotary cutter 18. The leading face of each blade has therein a series of parallel, closely spaced, shallow V-shaped grooves pro-

viding serrations 19 which occupy parallel planes that are convergent rearwardly to the plane of the bottom edge 20 of the blade. The angle of incidence of the serrations is small, preferably from one to five degrees, as indicated by the angle D in Figure 6 wherein the lines 19' and 20' designate, respectively, projections of the planes of the serrations and the bottom of the blade.

In the embodiment here shown the bottom edge 20 of the blade is inclined complementally to the bottom of the blade slot which is rearwardly inclined. This arrangement permits of a radial adjustment of the blade as it is moved forward, whereby the diameter of the cutter may be increased to provide for wear and regrinding. The slot bottom, however, and the bottom edge of the blade may be parallel to the main axis of the cutter if desired, and the radial adjustment of the blade may be obtained by other means.

In advance of the leading wall of each blade slot the cutter body is provided with a radially disposed, cylindrical, smooth bore 21 which opens at its bottom to a reduced, internally threaded bore 22 coaxial therewith. The combined bores receive a locking screw member 23 which, at its leading end, has a reduced shank 24 threaded for engagement in the socket formed by the bore 22. That portion of the locking screw which is received in the bore 21 is formed with a plurality of parallel annular serrations 25 which are complementary to the blade serrations 19. The serrations 25 of the locking screw are disposed with their ridges and bottoms in planes that are perpendicular to the axis of the screw, and they extend entirely around the periphery of the screw, presenting a plurality of conic bearing surfaces.

Each bore 21 opens through the leading wall of its adjacent blade slot so that the serrations 25 of the locking screw in each extend into the blade slot in mesh with the blade serrations. This arrangement requires that the blades be inserted from one end of their slots after the locking screws have been positioned. The trailing end of each screw is formed with an axial tool engageable socket 26 whereby the screws may be advanced or retracted.

It is a feature of the invention in the embodiments illustrated in Figures 5, 6, and 7, that the axis of the locking screw 23, designated by the line 30 in Figure 6, shall be inclined rearwardly from the perpendicular with respect to the bottom of the blade slot, forming therewith an angle of less than ninety degrees, as indicated by the angle C in Figure 6. Also, that the blade serrations are angled with respect to the bottom of the blade. This angling, particularly that of the blade serrations, creates a positive means preventing shifting of the blade rearwardly under the thrust strain of the cut when in service.

In locking a blade within its slot the locking screw is first positioned, and the blade is then inserted from the front face of the cutter and moved rearwardly with the blade serrations meshed with the concentric annular serrations on the head portion of the screw. Due to the angling of the serrations, the blade reaches a point at which further rearward movement is arrested. The blade cannot move rearwardly beyond such point without stripping either the blade serrations or the screw serrations. After the blade is thus seated the screw is given an advancing turn whereupon the conic surfaces comprising the inclined under faces of the screw ser-

rations 25 bear upon and wedge the inclined upper faces of the blade serrations 19, forcing the blade laterally against the trailing wall of its slot and at the same time downwardly against the slot bottom. A compound wedging action is obtained which securely anchors the blade in position. As the screw itself prohibits rearward movement of the blade beyond the point at which it is locked, all cutting thrust is absorbed by the screw, and the need of backing screws, such as shown in my said prior Patent No. 2,076,663 for instance, is eliminated.

The alternative embodiment shown in Figure 7 is identical with that of Figures 5 and 6 except for the configuration of the blade and screw serrations. In this form, the head portion of the locking screw 23' has its serrations 25' arranged as relatively lengthened cones; that is, the contact area of the under faces is made larger. The blade 17' is provided with complementary serrations 19'. The effect of this arrangement is to reduce the wedging angle and correspondingly increase the wedging power.

I claim:

1. In an inserted blade cutter, a body having a slot, said body having a bore therein adjacent the slot and opening through a wall thereof, a locking screw having an end portion threaded in a part of said bore, a plurality of conic bearing surfaces arranged on the other end portion of the screw as a concentric, longitudinal series, and a blade non-rotatably mounted in said slot and having in one side thereof a series of parallel, longitudinal serrations meshed with the conic bearing surfaces of the screw whereby the blade is securely wedged in place when the screw is advanced to locking position.
2. In an inserted blade cutter, a body having a slot, said body having a bore therein adjacent the slot and opening through a wall thereof, a locking screw having threaded engagement in said bore, a plurality of conic bearing surfaces on said screw, a blade non-rotatably mounted in said slot and having in one side thereof a series of parallel serrations meshed with the conic bearing surfaces of the screw whereby the blade is securely wedged in place when the screw is advanced to locking position, and said serrations being angled longitudinally with respect to the bottom edge of said blade.
3. In an inserted blade cutter, a body having a slot, said body having therein a bore adjacent the slot and opening through a wall thereof, a locking screw having threaded engagement with said bore, a plurality of concentric annular serrations on said screw and extending laterally into the blade slot, a blade non-rotatably mounted in the slot and having in one side thereof parallel serrations meshed with the screw serrations whereby the blade is securely wedged in place when the screw is advanced to locking position, the axis of said screw being rearwardly inclined with respect to the bottom of the blade slot, and the serrations on said blade being angled longitudinally with respect to the bottom edge of the blade.
4. In an inserted blade cutter, a body having a slot, said body having a bore therein adjacent the slot and opening through a wall thereof, a locking screw having threaded engagement with said body through said bore, a plurality of concentric annular serrations on the screw in said bore and extending laterally into the blade slot, a blade non-rotatably mounted in said slot and having longitudinally extending serrations in one

side thereof in mesh with the screw serrations whereby the blade is securely wedged in place when the screw is advanced to locking position, and said blade serrations being disposed in parallel planes rearwardly convergent with respect to the bottom edge of the blade.

5. In an inserted blade cutter, a body having a slot, said body having a bore therein adjacent the slot and opening through a wall thereof, a locking screw having threaded engagement with said body through said bore, a plurality of concentric annular serrations on the screw in said bore and extending laterally into the blade slot, a blade non-rotatably mounted in said slot and having longitudinally extending serrations in one side thereof in mesh with the screw serrations

whereby the blade is wedged in place when the screw is advanced to locking position, said blade serrations being disposed in parallel planes rearwardly convergent with respect to the bottom edge of the blade, and the axis of said screw being rearwardly inclined with respect to the bottom of the blade slot at an angle less than a right angle.

6. A blade for inserted blade cutters, comprising a body having a cutting edge, a bottom edge, and opposite side faces, and a series of longitudinally extending parallel serrations in one side face rearwardly convergent with respect to the bottom edge of the blade.

FRANK P. MILLER.