



(86) Date de dépôt PCT/PCT Filing Date: 2011/09/30
 (87) Date publication PCT/PCT Publication Date: 2012/04/05
 (85) Entrée phase nationale/National Entry: 2013/03/27
 (86) N° demande PCT/PCT Application No.: US 2011/054352
 (87) N° publication PCT/PCT Publication No.: 2012/045011
 (30) Priorités/Priorities: 2010/10/01 (US12/924,652);
 2011/06/23 (US13/135,041)

(51) Cl.Int./Int.Cl. *E03B 3/06* (2006.01),
B65D 90/00 (2006.01), *E03B 11/02* (2006.01)
 (71) Demandeur/Applicant:
 AMTROL LICENSING INC., US
 (72) Inventeurs/Inventors:
 BARETTA, DAVID, III, US;
 VAN HAAREN, CHRISTOPHER A., US
 (74) Agent: BERESKIN & PARR LLP/S.E.N.C.R.L.,S.R.L.

(54) Titre : DISPOSITIFS ET PROCEDES PERMETTANT D'ENTRAINER UN ECOULEMENT TURBULENT DANS UN ENSEMBLE RESERVOIR
 (54) Title: DEVICES AND METHODS FOR CAUSING TURBULENT FLOW IN A TANK ASSEMBLY

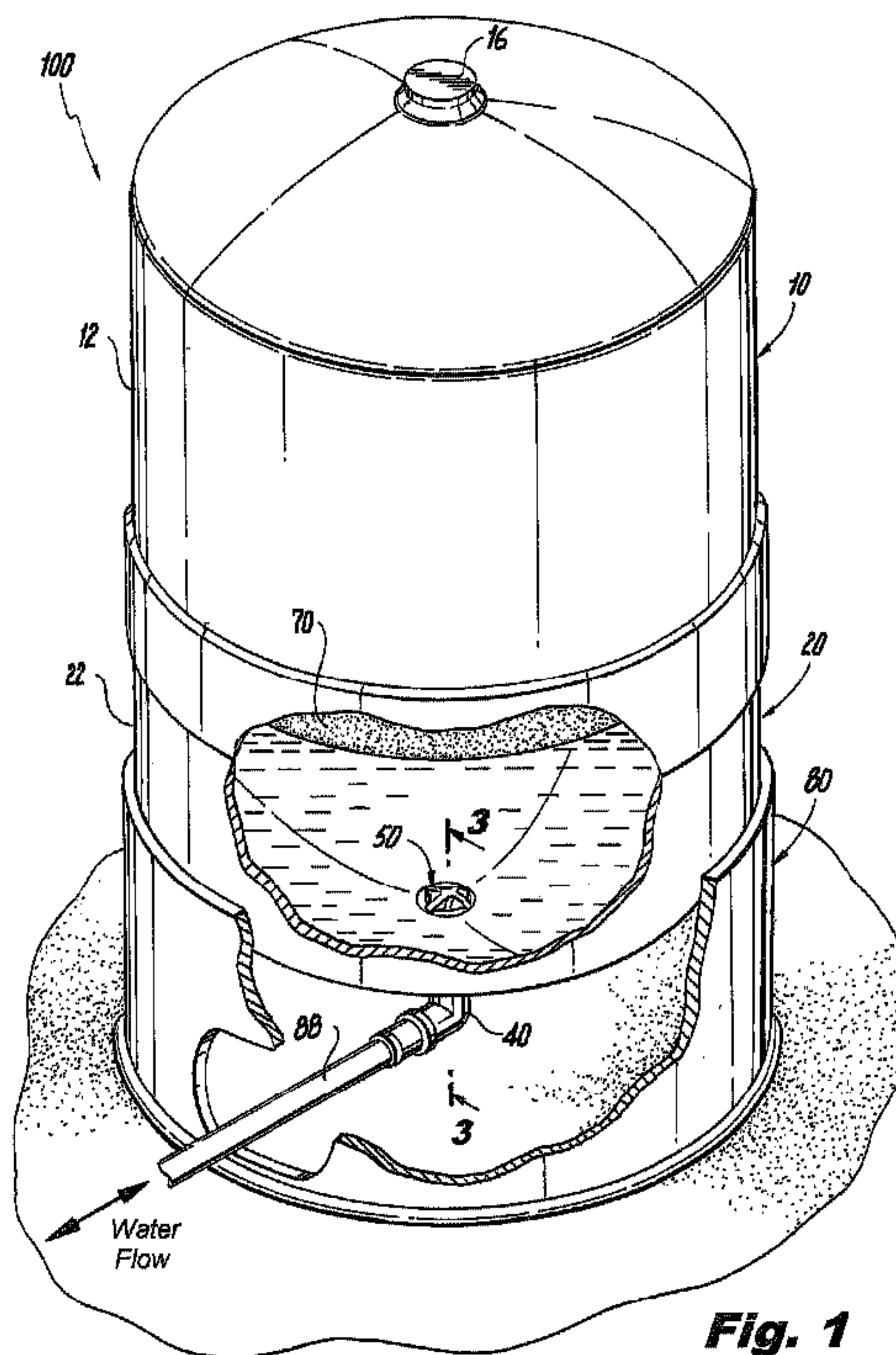

Fig. 1

(57) **Abrégé/Abstract:**

Disclosed is a device for causing turbulent flow in a tank assembly that includes, inter alia, a base portion and a vane element that extends in an axial direction from the base portion. The vane element has a curved surface formed at a distal end thereof which is adapted and configured to redirect fluid traversing the device axially in a non-axial direction. Still further, a plurality of shoulder elements extend radially outward from the axis of the vane element and are adapted and configured for limiting that axial insertion of the device into a fitting associated with the tank assembly. In an embodiment of the present invention, the vane element includes lateral edges which are adapted and configured for press-fit engagement with an inside diameter of the fitting associate with the tank assembly.



(12) INTERNATIONAL APPLICATION PUBLISHED UNDER THE PATENT COOPERATION TREATY (PCT)

(19) World Intellectual Property
Organization
International Bureau(43) International Publication Date
5 April 2012 (05.04.2012)(10) International Publication Number
WO 2012/045011 A3

- (51) International Patent Classification:
E03B 3/06 (2006.01) *E03B 11/02* (2006.01)
B65D 90/00 (2006.01)
- (21) International Application Number:
PCT/US2011/054352
- (22) International Filing Date:
30 September 2011 (30.09.2011)
- (25) Filing Language: English
- (26) Publication Language: English
- (30) Priority Data:
12/924,652 1 October 2010 (01.10.2010) US
13/135,041 23 June 2011 (23.06.2011) US
- (71) Applicant (for all designated States except US):
AMTROL LICENSING INC. [US/US]; 1400 Division
Road, West Warwick, RI 02893 (US).
- (72) Inventors; and
(75) Inventors/Applicants (for US only): **BARETTA, David, III** [US/US]; 30 Pardons Wood Lane, East Greenwich, RI 02818 (US). **VAN HAAREN, Christopher, A.** [US/US]; 22 Emily Lane, Warnick, RI 02886 (US).
- (74) Agent: **SILVIA, David, J.**; Edwards Angell Palmer & Dodge LLP, P.O. Box 55874, Boston, MA 02205 (US).
- (81) Designated States (unless otherwise indicated, for every kind of national protection available): AE, AG, AL, AM, AO, AT, AU, AZ, BA, BB, BG, BH, BR, BW, BY, BZ, CA, CH, CL, CN, CO, CR, CU, CZ, DE, DK, DM, DO, DZ, EC, EE, EG, ES, FI, GB, GD, GE, GH, GM, GT, HN, HR, HU, ID, IL, IN, IS, JP, KE, KG, KM, KN, KP, KR, KZ, LA, LC, LK, LR, LS, LT, LU, LY, MA, MD, ME, MG, MK, MN, MW, MX, MY, MZ, NA, NG, NI, NO, NZ, OM, PE, PG, PH, PL, PT, QA, RO, RS, RU, RW, SC, SD, SE, SG, SK, SL, SM, ST, SV, SY, TH, TJ, TM, TN, TR, TT, TZ, UA, UG, US, UZ, VC, VN, ZA, ZM, ZW.
- (84) Designated States (unless otherwise indicated, for every kind of regional protection available): ARIPO (BW, GH,

[Continued on next page]

(54) Title: DEVICES AND METHODS FOR CAUSING TURBULENT FLOW IN A TANK ASSEMBLY

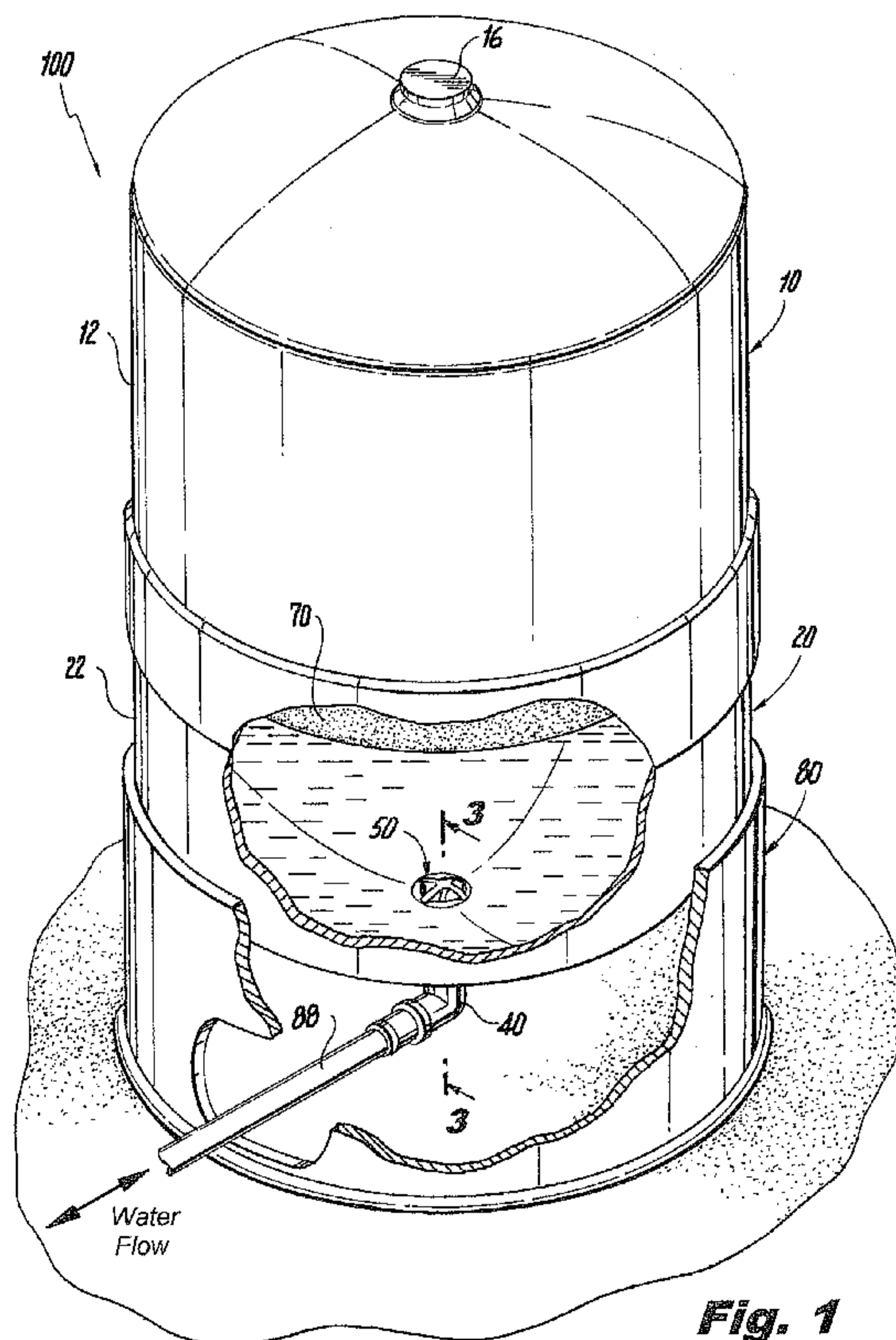

Fig. 1

(57) Abstract: Disclosed is a device for causing turbulent flow in a tank assembly that includes, *inter alia*, a base portion and a vane element that extends in an axial direction from the base portion. The vane element has a curved surface formed at a distal end thereof which is adapted and configured to redirect fluid traversing the device axially in a non-axial direction. Still further, a plurality of shoulder elements extend radially outward from the axis of the vane element and are adapted and configured for limiting that axial insertion of the device into a fitting associated with the tank assembly. In an embodiment of the present invention, the vane element includes lateral edges which are adapted and configured for press-fit engagement with an inside diameter of the fitting associated with the tank assembly.

WO 2012/045011 A3



GM, KE, LR, LS, MW, MZ, NA, RW, SD, SL, SZ, TZ, UG, ZM, ZW), Eurasian (AM, AZ, BY, KG, KZ, MD, RU, TJ, TM), European (AL, AT, BE, BG, CH, CY, CZ, DE, DK, EE, ES, FI, FR, GB, GR, HR, HU, IE, IS, IT, LT, LU, LV, MC, MK, MT, NL, NO, PL, PT, RO, RS, SE, SI, SK, SM, TR), OAPI (BF, BJ, CF, CG, CI, CM, GA, GN, GQ, GW, ML, MR, NE, SN, TD, TG).

Published:

— *with international search report (Art. 21(3))*

(88) Date of publication of the international search report:

19 July 2012

DEVICES AND METHODS FOR CAUSING TURBULENT FLOW IN A TANK ASSEMBLY

CROSS-REFERENCE TO RELATED APPLICATIONS

[0001] This application is a continuation-in-part application to currently pending U.S. Application Serial No. 12/924,652, filed October 1, 2010 and entitled DEVICE FOR CAUSING TURBULENT FLOW IN A TANK ASSEMBLY the disclosure of which is incorporated herein by reference.

BACKGROUND OF THE INVENTION

1. Field of the Invention

[0002] The subject invention is directed to devices and methods for causing turbulent flow in a tank assembly, and more particularly to, devices associated with a tank's fluid inlet which create turbulent flow within the tank, a still more particularly to, devices for use with a tank assembly, such as a well tank, which include at least one vane elements that alters the direction of fluid flow entering the tank, so as to cause turbulent flow within the tank.

2. Description of the Related Art

[0003] Water systems that provide and distribute well water domestically in rural parts of the country typically include a pump to draw water from the well; pipes or other conduits through which water travels; and a tank for storing water, e.g., a well tank. Well tanks, e.g., expansion tanks, are structured and arranged to store water until demanded and to accommodate internal pressures of the system. To this end, well tanks typically provide an air cushion for the supply water.

[0004] Generally, the water chamber in the interior of the tank assembly that stores water is in fluid communication through a fitting with the pipes or conduits of the domestic water system. By design, the water chamber is structured and arranged to provide an

operating pressure, e.g., about 20 to 40 pounds per square inch ("psi"), to the water system. To accomplish this, a compressible gas chamber contains a pressurized gas, e.g., nitrogen or, more preferably, air, that can force water through the water system and that, further, can prevent creation of negative or back pressures in the water system during the cyclical demand for water and/or volume changes associated with the change in water temperature. If the pressure in the water chamber falls below the operating pressure, the pump is activated and water is added to the water chamber of the expansion tank until the water chamber again provides the operating pressure.

[0005] In any closed system containing air and water that undergoes natural or artificial temperature changes, the likelihood of problems stemming from interaction of air and water is great. Air is soluble in water and water readily absorbs air. Without an air cushion, or, more specifically, air pressure to force water through the system, a pressure pump may be needed constantly. Optionally, an air surge chamber can be provided that is not in direct contact with the water, thereby eliminating the need of the pressure pump operating every time a faucet was turned on. Pressure pumps and surge chambers increase the cost of a water system.

[0006] To address these shortcomings, conventional expansion and well tanks (collectively "tank assemblies") typically include impermeable diaphragms, or bladders, to separate the interior of the well tank into two chambers, or cells: a liquid, or water, chamber and a compressible, or pressurized, gas chamber. As water is pumped from a well into the tank assembly, the volume of the water in the water chamber increases, causing the diaphragm to contract the volume of the pressurized gas chamber. As the volume of the pressurized gas chamber decreases, the gas pressure in the pressurized gas chamber increases. As a result, when water for the tank is demanded by the water system, the gas in the

pressurized gas chamber forces the water into the water system. Consequently, the volume of water in the water chamber decreases and the volume of the pressurized gas chamber increases. As a result, the pressure of the pressurized gas decreases.

[0007] Conventional diaphragms are constructed of a non-porous, elastic material, e.g., plastic or butyl rubber, and are sealed at the periphery or sidewall of the tank to provide an air- and watertight seal. Not only does use of a diaphragm avoid the above-described air-water problems, but, also, separation of water from the pressurized gas is desirable because water in the presence of oxygen produces oxidation that can damage metal or other portions of the system and, furthermore, can aerate the water, which can affect water quality.

[0008] An example of a conventional tank assembly is provided in commonly assigned U.S. Pat. No. 5,386,925 to Lane, which is herein incorporated by reference in its entirety. The Lane patent provides an expansion tank that includes a deformable diaphragm that divides the tank into two sections. The diaphragm separates the gas in the one section of the tank from the water in the other section of the tank and the rest of the system. The gas section is pre-charged with gas under pressure so that the diaphragm is displaced to increase or decrease the volume of this section according to the variations of the volume of water in the other section.

[0009] In certain well tank constructions, to provide some protection from corrosion, the inner surface of the liquid chamber portion of the metal expansion tank is covered by a water, or liquid impervious liner.

[00010] A disadvantage associated with conventional tank assemblies, such as the one disclosed in Lane, is that sediment builds up in the tank over time and ultimately degrades the tank. As noted above, water is pumped into the fluid cell of the tank from a well pump. In many parts of the country, the well water contains sediment. As shown in Figure 1 of U.S.

Pat. No. 5,386,925 to Lane, the water enters the tank through a fitting 130 vertically and in an axial direction. Over time, the sediment contained in the water settles to the bottom of the tank where it is undisturbed and remains for the life of the tank.

[00011] An additional problem encountered in some conventional tank assemblies is that pockets of stagnant water develop within the fluid cell, resulting in the water becoming stale.

[00012] Therefore, it would be desirable to provide a tank assembly that is capable of removing the sediment from within the water cell and preventing pockets of stagnant water from developing. Moreover, it would be desirable to provide a low-cost solution to the above-mentioned problems which can be easily adapted to existing tank designs without creating a significant pressure loss within the system.

SUMMARY OF THE INVENTION

[00013] The present invention is directed to a device for causing turbulent flow in a tank assembly that includes, *inter alia*, a base portion and a vane element that extends in an axial direction from the base portion. The vane element has a curved surface formed at a distal end thereof which is adapted and configured to redirect fluid traversing the device axially in a non-axial direction. Still further, a plurality of shoulder elements extend radially outward from the axis of the vane element and are adapted and configured for limiting that axial insertion of the device into a fitting associated with the tank assembly.

[00014] In an embodiment of the present invention, the vane element includes lateral edges which are adapted and configured for press-fit engagement with an inside diameter of the fitting associate with the tank assembly.

[00015] Preferably, a cross-section of the base portion taken perpendicular to the axis for the device is cruciform-shaped. It is also envisioned that the device further includes a stiffening rib associate with the vane element. In such an embodiment, the cross-section of the vane element may also be cruciform-shaped. In certain constructions, the stiffening rib associated with the vane element includes lateral edges which are adapted and configured for press-fit engagement with an inside diameter of the fitting associate with the tank assembly.

[00016] It is presently preferred that the base portion include guide surfaces for diverting fluid axially towards the curved surface of the vane element.

[00017] In certain constructions of the present invention, the device further includes first and second retaining arms which extend axially from the base portion. Each retaining arm can include a hook portion formed at a distal end thereof for supporting the device substantially within a fitting of a tank assembly. It is envisioned that the retaining arms are flexible so as to allow the hook portion to be biased in a radially inward direction.

[00018] The present invention is also directed to a tank assembly that includes, among other elements, an outer housing defining an interior fluid cell; a fitting secured to the outer housing which defines a fluid passage which extends from an exterior of the housing to the interior fluid cell so as to allow fluid to enter and exit the fluid cell; and a flow diverter disposed within the fluid passage defined by the fitting for causing turbulent flow within the interior fluid cell by redirecting fluid entering the tank assembly axially through the fitting in a non-axial direction into the fluid cell.

[00019] Preferably, the flow diverter has lateral edges which are adapted and configured for press-fit engagement with an inside diameter of the fitting of the tank assembly.

[00020] In an embodiment of the present invention, the flow diverter includes a base portion and a vane element that extends in an axial direction from the base portion. The vane element has a curved surface formed at a distal end thereof which is adapted and configured to redirect fluid traversing the device axially in a non-axial direction. Still further, a plurality of shoulder elements extend radially outward from the axis of the vane element and are adapted and configured for limiting that axial insertion of the device into a fitting associated with the tank assembly.

[00021] Preferably, a cross-section of the base portion taken perpendicular to the axis for the device is cruciform-shaped. It is also envisioned that the device further includes a stiffening rib associate with the vane element. In such an embodiment, the cross-section of the vane element may also be cruciform-shaped. In certain constructions, the stiffening rib associated with the vane element includes lateral edges which are adapted and configured for press-fit engagement with an inside diameter of the fitting associate with the tank assembly.

[00022] It is presently preferred that the base portion include guide surfaces for diverting fluid axially towards the curved surface of the vane element.

[00023] In certain constructions of the present invention, the flow diverter further includes first and second retaining arms which extend axially from the base portion. Each retaining arm can include a hook portion formed at a distal end thereof for supporting the flow diverter substantially within a fitting of a tank assembly. It is envisioned that the retaining arms are flexible so as to allow the hook portion to be biased in a radially inward direction.

[00024] The present invention is also directed to a device for causing turbulent flow in a tank assembly that has an internal fluid cell and a fitting for allowing fluid to enter and exit the fluid cell from the exterior of the tank assembly. The device includes, *inter alia*, a base

portion and a vane element. The base portion defines a central axis for the device and has a top surface and a bottom surface. The vane element extends axially from the base portion of the device and includes a curved surface which is adapted and configured for causing turbulent flow in the fluid cell of the tank assembly by redirecting fluid entering the tank assembly axially through the fitting in a non-axial direction into the fluid cell.

[00025] Preferably, the vane element includes lateral edges which are adapted and configured for press-fit engagement with an inside diameter of the fitting associate with the tank assembly. It is envisioned in certain embodiments, the cross-section of the base portion taking perpendicular to the axis for the device is cruciform-shaped.

[00026] These and other features and benefits of the subject invention and the manner in which it is assembled and employed will become more readily apparent to those having ordinary skill in the art from the following enabling description of the preferred embodiments of the subject invention taken in conjunction with the several drawings described below.

BRIEF DESCRIPTION OF THE DRAWINGS

[00027] So that those skilled in the art to which the subject invention appertains will readily understand how to make and use the methods, devices and systems of the subject invention without undue experimentation, preferred embodiments thereof will be described in detail hereinbelow with reference to certain figures, wherein:

[00028] Fig. 1 is a perspective view of a tank assembly which has been constructed in accordance with a preferred embodiment of the present invention having portions of its stand and dome cut away for ease of illustration;

[00029] Fig. 2 is an exploded perspective view of the tank assembly of Fig. 1 wherein the upper and lower halves of the tank dome have been separated so as to show the interior of the fluid cell and the flow diverter;

[00030] Fig. 3 is a partial cross-sectional view of the bottom of the tank assembly of Fig. 1 which illustrates the flow diverter of the present invention installed within the tank inlet/outlet fitting;

[00031] Fig. 4 is a side elevation of an embodiment of the flow diverter of the present invention;

[00032] Fig. 5 is a top plan view of the flow diverter of Fig. 4;

[00033] Fig. 6 is a cross-sectional view of the bottom of the tank assembly of Fig. 1 which illustrates the manner in which the flow diverter of Fig. 4 causes turbulent flow within the fluid cell of the tank assembly;

[00034] Fig. 7 is a perspective view taken from within the fluid cell of the tank assembly which illustrates the manner in which the flow diverter of Fig. 4 causes turbulent flow within the cell;

[00035] Fig. 8 is a cross-sectional view of a portion of the flow diverter of Fig. 4 and the bottom of the tank assembly which illustrates the manner in which the flow diverter prevents the diaphragm from being drawn into the inlet/outlet fitting when all of the water has been discharged from within the fluid cell;

[00036] Fig. 9 provides a perspective view of a second embodiment for the flow diverter of the present invention;

[00037] Fig. 10 provides a perspective view from within the fluid cell of the tank assembly illustrating the manner in which the flow diverter of Fig. 9 creates turbulent flow within the fluid cell;

[00038] Fig. 11 provides a perspective view of a third embodiment of the flow diverter of the present invention;

[00039] Fig. 12 provides a side elevational view of the flow diverter of Fig. 11;

[00040] Fig. 13 provides a cross-sectional view of the bottom of a tank assembly that includes an elbow fitting into which the flow diverter of Fig. 11 is press-fit so as to cause turbulent flow within the fluid cell of the tank assembly;

[00041] Fig. 14 provides a cross-sectional view of the bottom of a tank assembly that includes a T-shaped fitting into which the flow diverter of Fig. 11 is disposed so as to cause turbulent flow within the fluid cell of the tank assembly;

[00042] Fig. 15a-c provide a perspective view, a front view and a side elevational view of a fourth embodiment of the flow diverter of the present invention;

[00043] Fig. 16 provides a cross-sectional view of the bottom of a tank assembly that includes an elbow fitting into which the flow diverter of Fig. 15 is disposed so as to cause turbulent flow within the fluid cell of the tank assembly; and

[00044] Fig. 17 provides a cross-sectional view of the bottom of a tank assembly that includes a T-shaped fitting into which the flow diverter of Fig. 15 is disposed so as to cause turbulent flow within the fluid cell of the tank assembly.

[00045] These and other aspects of the subject invention will become more readily apparent to those having ordinary skill in the art from the following detailed description of the invention taken in conjunction with the drawings.

DETAILED DESCRIPTION OF PREFERRED EMBODIMENTS

[00046] Disclosed herein are detailed descriptions of specific embodiments of the devices, systems and methods for causing turbulent flow in a tank assembly, such as a well tank. It will be understood that the disclosed embodiments are merely examples of the way in which certain aspects of the invention can be implemented and do not represent an exhaustive list of all of the ways the invention may be embodied. Indeed, it will be understood that the systems, devices, and methods described herein may be embodied in various and alternative forms. The figures are not necessarily to scale and some features may be exaggerated or minimized to show details of particular components. Well-known components, materials or methods are not necessarily described in great detail in order to avoid obscuring the present disclosure. Any specific structural and functional details disclosed herein are not to be interpreted as limiting, but merely as a basis for the claims and as a representative basis for teaching one skilled in the art to variously employ the invention.

[00047] For ease of description, the components of this invention are described in an upright operating position, and terms such as upper, lower, front, rear, horizontal, etc., are used with reference to this position. It will be understood, however, that the components of this invention may be manufactured, stored, transported, used, and sold in an orientation other than the position described.

[00048] Figures illustrating the components show some mechanical elements that are known and will be recognized by one skilled in the art. The detailed descriptions of such elements are not necessary to an understanding of the invention, and accordingly, are herein presented only to the degree necessary to facilitate an understanding of the novel features of the present invention.

[00049] Referring now to the drawings wherein similar reference numerals identify similar structural features or aspects of the subject invention, there is illustrated in Fig. 1, an expansion tank or tank assembly which has been designated by reference numeral 100.

[00050] Expansion tank 100 includes upper cylindrical body 10 and lower cylindrical body 20. Upper cylindrical body 10 has a side wall 12 and an end wall 14, which is provided with an orifice (not shown - covered by cap 16). Lower cylindrical body 20 has a side wall 22 and an end wall 24 which is also provided with orifice 26 (see Fig. 2).

[00051] The interior surface of the lower end wall 24 and the lower portion of the lower side wall 22 are covered by a liquid-impervious liner 30, which is composed preferably of a plastic capable of withstanding temperatures of at least 212° F., such as, polypropylene, so that the water of a hot water heating system or a pressurized well water system is separated from the interior surfaces of the lower cylindrical body 20. Also, plastic liner 30 will not deteriorate due to the temperature or type of water with which expansion tank 100 is used. Liner 30 can be manufactured by any suitable technique known to the art; such as, vacuum forming, injection molding, etc.

[00052] The plastic liner 30 is formed with an orifice 32 which mates with orifice 26 in end wall 24 of lower cylindrical body 20. The portion of liner 30 adjacent the orifice is clamped to lower end wall 24, welded, brazed or otherwise suitably connected to tank 100 and adapted to connect expansion tank 100 with the water system of which it forms a part.

[00053] Flexible diaphragm 70, formed of butyl rubber or other elastomer, is disposed inside of lower cylindrical body 20 and is adapted to conform to the shape thereof. The manner in which diaphragm 70 is secured to lower cylindrical body 20 is not the subject of the present invention and therefore will not be discussed herein. However, U.S. Patent No.

5,386,925 provides a representative method for securing an internal diaphragm within a well tank.

[00054] A conventional air check valve is secured in the orifice formed in the end wall 14 of the upper cylindrical body 10 and permits air under pressure to be introduced into the gas receiving section or gas cell 90 (see Fig. 6) between the diaphragm 70 and upper cylindrical body 10. After the pressure in gas cell 90 is raised to the desired value, the check valve is covered as shown.

[00055] When installed, expansion tank 100 is supported on stand 80. Stand 80 has a cylindrical side wall 82 which allows fitting 40 to extend below end wall 24 of the lower cylindrical body 20. Side wall 82 includes a cutout 84 for allowing the water supply/return line 88 to extend from the fitting 40 to the exterior of the tank assembly 100.

[00056] A flow diverter insert 50 is positioned at least partially within orifice 42 of fitting 40. As best illustrated in Figs. 4 and 5, flow diverter insert 50 includes, *inter alia*, a main body portion 52 and first and second retaining arms 54. The main body portion 52 defines a central axis "A" for the flow diverter 50 and has a top surface 56, a bottom surface 58 and radially opposed lateral side walls 62a/b.

[00057] The first and second retaining arms 54 extend from the bottom surface 58 of the main body portion 52 of flow diverter 50. Each retaining arm 54 includes a radially outer surface or ledge 64 located at a distal end thereof which is adapted and configured for supporting the flow diverter 50 substantially within the fitting 40 of the tank assembly 100.

[00058] The flow diverter insert 50 further includes two vane elements 66a/b that extend from the opposing lateral side walls 62a/b of the main body portion 52. Each vane element 66a/b includes a curved surface 68 (see Fig. 4) which is adapted and configured for causing turbulent flow in the fluid cell 92 of the tank assembly 100. The manner in which the

vane elements 66a/b create the turbulent flow within the fluid cell 92 is best shown in Figs. 6 and 7. The curved surface 68 of vane elements 66 redirect the fluid entering the tank assembly 100 axially through the fitting 40 in a non-axial direction into the fluid cell 92. By directing the inlet flow in this manner, the fluid circulates within the fluid cell 92 as shown in Fig. 6. This turbulent circulation path allows the fluid to disrupt any stagnant pockets of fluid and to sweep up the sediment "S" that has collected along the bottom of the tank, so that it becomes suspended in the fluid for a period of time. Then when the fluid/water is needed by the system or within the residence the water and suspended sediment exit the tank and passes through a sediment filter, which removes sediment from within the tank and from the water supply.

[00059] As noted above, the flow diverter 50 is supported within fitting 40 and each retaining arm 54 includes a ledge 64 located at a distal end thereof which is adapted and configured for securing the flow diverter 50 substantially within the fitting 40.

[00060] Each end of the main body portion 52 of the flow diverter 50 and each vane element 66 includes a radiused shoulder, 55 and 69 respectively, which engages with the top of fitting 40 and in combination with ledges 64, secures the flow diverter 50 within the fitting 40.

[00061] In the embodiment shown herein, the retaining arms 54 are resilient and can be flexed radially inward, so as to allow the flow diverter 50 to be inserted into the fitting 40 of the tank assembly 100. When the flow diverter 50 is fully inserted within the fitting 40, the retaining arms 54 flex outward such that the ledges 64 engage with corresponding shoulders formed on the inside diameter of fitting 40, which prevents the removal of flow diverter 50 from within fitting 40.

[00062] As shown in Figs. 4 and 6, each of vane elements 66 includes a curved surface 68 which redirects the fluid entering the fluid cell 92 in the same, non-axial direction. However, those skilled in the art will readily appreciate that in alternative embodiments, the vane elements 66 can be constructed such that they direct the flow of fluid in differing directions.

[00063] Referring now to Fig. 8 which illustrates a cross-section of the tank assembly 100 taken around the top of the fitting 40. This figure depicts the tank assembly 100 in the condition where almost all of the fluid has been removed from fluid cell 92. When this condition exists, the top surface 56 of the main body portion 52 of the flow diverter 50 prevents the diaphragm 70 from being drawn into the fitting 40 and possible be damaged.

[00064] Referring now to Figs. 9 and 10 which illustrate an alternative embodiment of the flow diverter of the present invention which has been designated as reference number 150. Like the previously described embodiment, flow diverter insert 150 includes, *inter alia*, a main body portion 152 and first and second retaining arms 154. The main body portion 152 defines a central axis "A" for the flow diverter 150 and has a top surface 156 and a bottom surface 158. The first and second retaining arms 154 extend from the bottom surface 158 of the main body portion 152 of flow diverter 150. Each retaining arm 154 includes a radially outer surface/ledge 164 located at a distal end thereof which is adapted and configured for supporting the flow diverter 150 substantially within a fitting of a tank assembly.

[00065] Unlike the previously described embodiment, wherein angled vane elements 66 were used to create the turbulent flow within the fluid cell of the tank, in this embodiment flow orifices 166 have been created in the main body portion 152 of the flow diverter 150. These orifices 166 have been stamped into the main body portion 152 of the diverter 150, but other techniques can be used to form the orifices. Two of the orifices 166b/d have been

completely stamped out along their outer diameter such that a circular piece of material has been removed. The remaining two orifices 166a/c have only been partially stamped out, such that a substantially circular tab 168 remains hanging from the main body portion 152 of the flow diverter 150. During the fabrication process, tabs 168 are arranged at an acute angle with respect to the top surface 156 of the main body 152 acts, so as to create vane elements that redirect the inflow from an axial direction to a non-axial direction, similar to vane elements 66 of flow diverter 50.

[00066] Referring now to Figures 11 through 14, which illustrate a further embodiment of the flow diverter of the present invention which has been designate as reference numeral 250. Flow diverter 250 can be used to create turbulent flow in a tank assembly, such as the one shown in Fig. 1. Flow diverter 250 includes a base portion 252 and a vane element 266 that extends in an axial direction (along axis A-A) from the base portion 252. The vane element 266 has a curved surface 268 formed at its distal end 272. As will be described herein below, the curved surface 268 of vane element 266 redirects the fluid traversing the flow diverter 250 axially in a non-axial direction.

[00067] A plurality of shoulder elements 274a-274d or stops extend radially outward from the central axis A-A of vane element 266. As will be discussed below, the shoulder elements 274a-274d limit the amount the flow diverter 250 can be inserted into the inlet fitting associated with the tank assembly. Each shoulder element includes a radiused upper surface 276 and a radiused lower surface 278 that provides a transition to the base portion 252 of the flow diverter 250.

[00068] The vane element 266 includes opposed lateral edges 280a/280b which are tapered slightly inward from the bottom of the vane element to the top. The spacing between

the lateral edges 280a/280b has been selected such that the flow diverter 250 can be secured within the inlet fitting by press-fit engagement with an inside diameter of the fitting.

[00069] The cross-section of the base portion 252 taken perpendicular to the axis A-A for flow diverter 250 is cruciform-shaped. Flow diverter 250 also includes two stiffening ribs 282 associate with the vane element 266. As a result, the cross-section of the vane element 266 is also cruciform-shaped. The stiffening ribs 282 each include a lateral edges 242a/284b and the size of the rib 282 are selected so as to assist in frictionally retaining the flow diverter 250 within the fitting of the tank assembly.

[00070] Base portion 252 also includes guide surfaces 286 for diverting fluid axially towards the curved surface 268 of the vane element 66.

[00071] Figures 11 and 12 illustrate flow diverter 250 installed within a fitting assembly associated with a well tank. The inlet fitting assembly includes, a steel fitting, an insert 290, which is normally formed with stainless steel, an O-ring gasket 292 and a stainless steel washer 294. When completely assembled, the inner plastic liner (not shown) of the tank assembly is sandwiched between the stainless steel washer 294 and the O-ring gasket 292 and the end wall associated with the lower cylindrical body of the tank assembly is sandwiched between the fitting 240 and the O-ring gasket 292. The fitting 240 is typically welded to the lower cylindrical body of the tank assembly.

[00072] Figure 13 shows an elbow joint 298 connected to fitting 240 and Figure 14 illustrates a T-shaped junction 398 secured to fitting 240. Prior to connecting either the elbow joint 298 or T-shaped junction 398 to the fitting 240, vane element 266 of flow diverter 250 is inserted into the fluid passage defined by the fitting 240 and insert 290. The lateral edges of the vane element 266 and/or the support ribs 282 frictionally engage with the inner diameter of the insert 290 and a press-fit connection is formed so as to secure the flow

diverter 250 in place. The shoulder elements 274a-274d or stops limit the amount the flow diverter 250 can be inserted into the inlet fitting assembly associated with the tank and prevent it from being inserted too far.

[00073] In the installed position, the base portion 252 of flow diverter 250 projects into the elbow 298 or T-shaped junction 398. The guide surfaces 298 (Fig. 13) formed on the base portion 252 help to direct the flow of water up into the fitting assembly. Then, the curved surface 268 of vane element 266 redirect the fluid entering the tank assembly 100 axially through the fitting 240 in a non-axial direction into the fluid cell. By directing the inlet flow in this manner, the fluid circulates within the fluid cell as shown in Fig. 6. This turbulent circulation path allows the fluid to disrupt any stagnant pockets of fluid and to sweep up the sediment "S" that has collected along the bottom of the tank, so that it becomes suspended in the fluid for a period of time. Then when the fluid/water is needed by the system or within the residence the water and suspended sediment exit the tank and passes through a sediment filter, which removes sediment from within the tank and from the water supply.

[00074] Referring now to Figures 15a through 17 wherein there is illustrated a further flow diverter embodiment of the present invention which has been designated by reference numeral 350. Like the previously described flow diverters, flow diverter 350 can be used to create turbulent flow in a tank assembly, such as the one shown in Fig. 1.

[00075] Flow diverter 350 includes a base portion 352 and a vane element 366 that extends in an axial direction (along axis A-A) from the base portion 352. The vane element 366 has a curved surface 368 formed at its distal end 372. Curved surface 368 of vane element 3266 redirects the fluid traversing the flow diverter 350 axially in a non-axial direction.

[00076] A plurality of shoulder elements 374a-374d or stops extend radially outward from the central axis A-A of vane element 366. The shoulder elements 374a-374d limit the amount the flow diverter 350 can be inserted into the inlet fitting associated with the tank assembly.

[00077] Flow diverter 350 further includes first and second retaining arms 354a/354b which extend axially from the base portion 352. Each retaining arm 354a/354b includes a hook portion 356 formed at a distal end 372 for supporting the flow diverter 350 substantially within a fitting 340 of a tank assembly as shown in Figs. 16 ad 17. The retaining arms 354a/354b are flexible so as to allow the hook portion 356 to be biased in a radially inward direction when the flow diverter is inserted into the fitting 340. When the flow diverter 350 is fully inserted into the fitting, as shown in Figs. 16 and 17, the shoulder elements 374a-374d contact the bottom of the fitting 340 and the retaining arms 354a/354b flex outward to their original position and as a result, the hook portions 356 lock the flow diverter 350 in place.

[00078] Like the previously described embodiment, the base portion 252 of the flow diverter 350 extends into the elbow or T-shaped connection 298/398 and the cruciform shape helps guide fluid up into the interior passage defined by the inlet fitting.

[00079] While the subject invention has been described with respect to preferred embodiments, those skilled in the art will readily appreciate that changes and modifications may be made thereto without departing from the spirit and scope of the subject invention as defined by the appended claims.

What is claimed is:

1. A device for causing turbulent flow in a tank assembly, comprising:
 - a) a base portion;
 - b) a vane element extending in an axial direction from the base portion, the vane element including a curved surface formed at a distal end thereof, the curved surface being adapted and configured to redirect fluid traversing the device axially in a non-axial direction; and
 - c) a plurality of shoulder elements extending radially outward from the axis of the vane element and adapted and configured for limiting axial insertion of the device into a fitting assembly associated with the tank.

2. A device for causing turbulent flow in a tank assembly as recited in Claim 1, wherein the vane element includes lateral edges which are adapted and configured for press-fit engagement with an inside diameter of the fitting assembly associate with the tank.

3. A device for causing turbulent flow in a tank assembly as recited in Claim 1, wherein a cross-section of the base portion taken perpendicular to the axis for the device is cruciform-shaped.

4. A device for causing turbulent flow in a tank assembly as recited in Claim 1, further comprising a stiffening rib associate with the vane element.

5. A device for causing turbulent flow in a tank assembly as recited in Claim 4, wherein the stiffening rib includes lateral edges which are adapted and configured for press-fit engagement with an inside diameter of the fitting assembly associate with the tank.
6. A device for causing turbulent flow in a tank assembly as recited in Claim 1, wherein the base portion includes guide surfaces for diverting fluid axially towards the curved surface of the vane element.
7. A device for causing turbulent flow in a tank assembly as recited in Claim 1, further comprising first and second retaining arms which extend axially from the base portion of the device
8. A device for causing turbulent flow in a tank assembly as recited in Claim 1, wherein each retaining arm includes a hook portion formed at a distal end thereof for supporting the device substantially within a fitting of a tank assembly.
9. A device for causing turbulent flow in a tank assembly as recited in Claim 8, wherein the retaining arms are flexible so as to allow the hook portion to be biased in a radially inward direction.

10. A tank assembly comprising:
- a) an outer housing defining an interior fluid cell;
 - b) a fitting secured to the outer housing which defines a fluid passage which extends from an exterior of the housing to the interior fluid cell so as to allow fluid to enter and exit the fluid cell; and
 - c) a flow diverter disposed within the fluid passage defined by the fitting for causing turbulent flow within the interior fluid cell by redirecting fluid entering the tank assembly axially through the fitting in a non-axial direction into the fluid cell.
11. A tank assembly as recited in Claim 10, wherein the flow diverter includes lateral edges which are adapted and configured for press-fit engagement with an inside diameter of the fitting assembly of the tank.

12. A tank assembly as recited in Claim 10, wherein the flow diverter comprises:
- a) a base portion;
 - b) a vane element extending in an axial direction from the base portion, the vane element including a curved surface formed at a distal end thereof, the curved surface being adapted and configured to redirect fluid traversing the device axially in a non-axial direction; and
 - c) a plurality of shoulder elements extending radially outward from the axis of the vane element and adapted and configured for limiting axial insertion of the device into a fitting assembly associated with the tank.
13. A tank assembly as recited in Claim 12, wherein the vane element includes lateral edges which are adapted and configured for press-fit engagement with an inside diameter of the fitting assembly associate with the tank.
14. A tank assembly as recited in Claim 10, wherein a cross-section of the flow diverter taken perpendicular to the fitting axis is cruciform-shaped.
15. A tank assembly as recited in Claim 12, further comprising a stiffening rib associate with the vane element.

16. A tank assembly as recited in Claim 15, wherein the stiffening rib includes lateral edges which are adapted and configured for press-fit engagement with an inside diameter of the fitting assembly associate with the tank.

17. A tank assembly as recited in Claim 10, wherein a lower end of the flow diverter includes guide surfaces for diverting fluid into the fitting assembly axially towards the fluid cell.

18. A tank assembly as recited in Claim 12, further comprising first and second retaining arms which extend axially from the base portion of the device

19. A tank assembly as recited in Claim 18, wherein each retaining arm includes a hook portion formed at a distal end thereof for supporting the device substantially within a fitting assembly of a tank.

20. A device for causing turbulent flow in a tank assembly that has an internal fluid cell and a fitting for allowing fluid to enter and exit the fluid cell from the exterior of the tank assembly, the device comprising:

a) a base portion defining a central axis for the device and having a top surface and a bottom surface; and

b) a vane element extending axially from the base portion of the device that includes a curved surface which is adapted and configured for causing turbulent flow in the fluid cell of the tank assembly by redirecting fluid entering the tank assembly axially through the fitting in a non-axial direction into the fluid cell.

21. A device for causing turbulent flow in a tank assembly as recited in Claim 20, wherein the vane element includes lateral edges which are adapted and configured for press-fit engagement with an inside diameter of the fitting associate with the tank assembly.

22. A device for causing turbulent flow in a tank assembly as recited in Claim 20, wherein a cross-section of the base portion taking perpendicular to the axis for the device is cruciform-shaped.

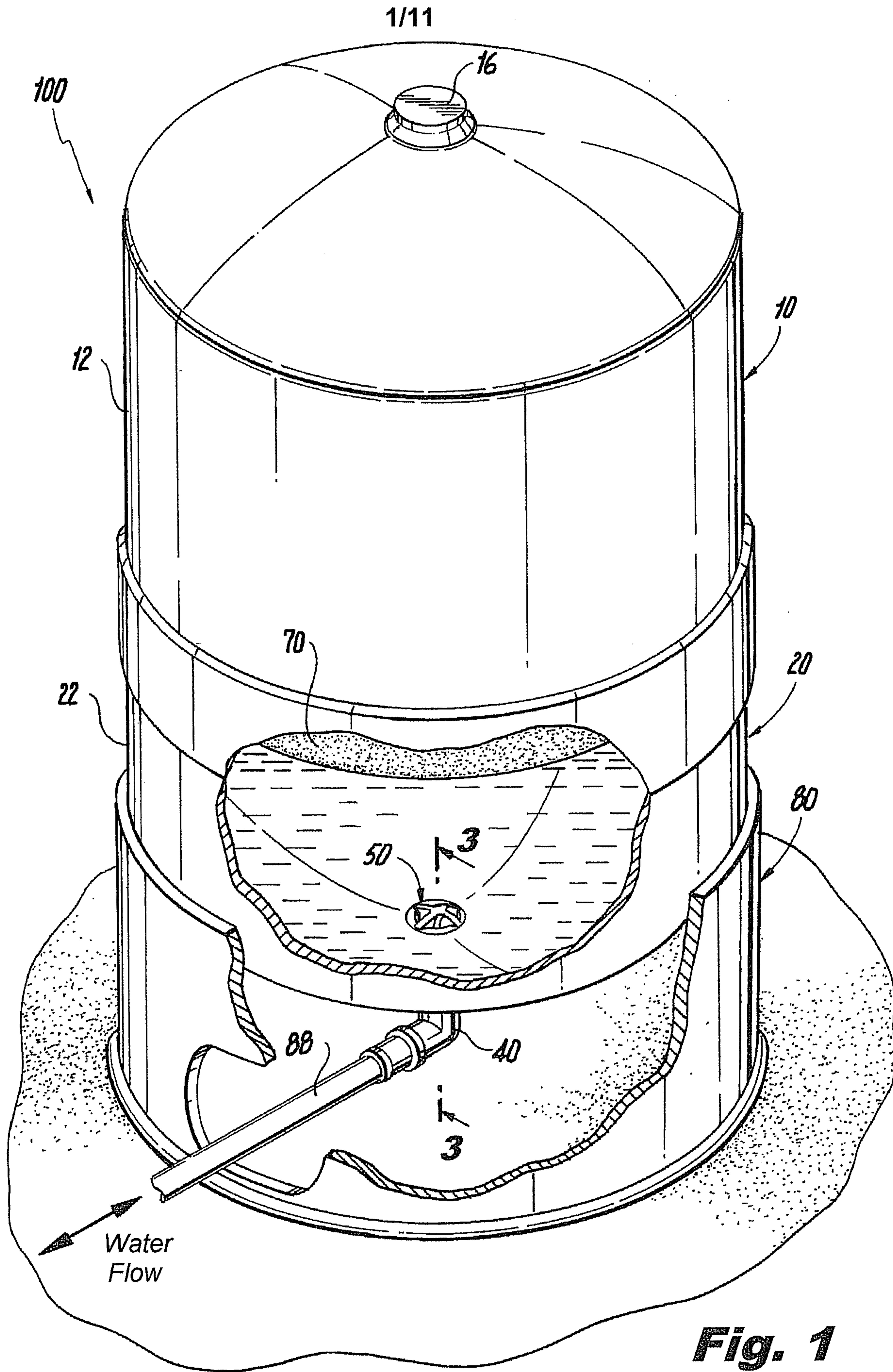

Fig. 1

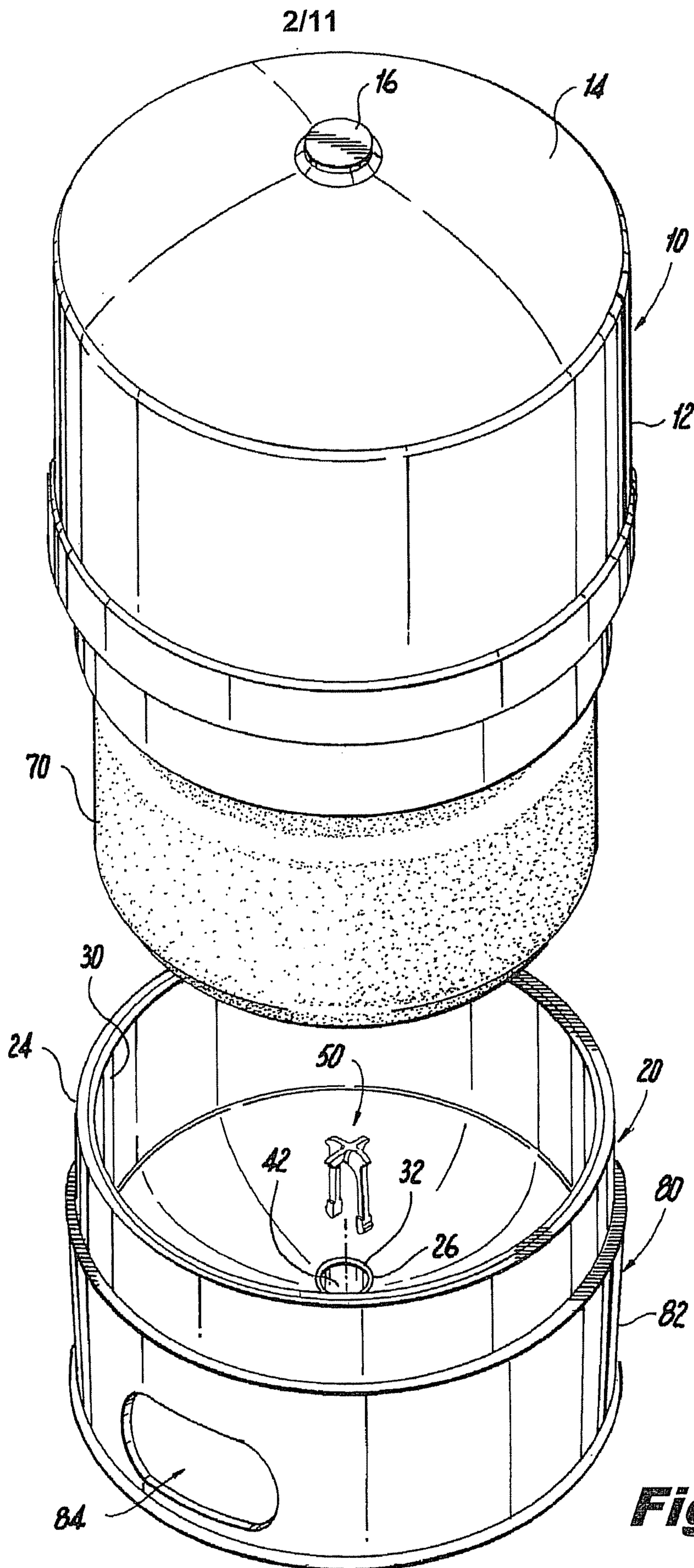

Fig. 2

Fig. 3

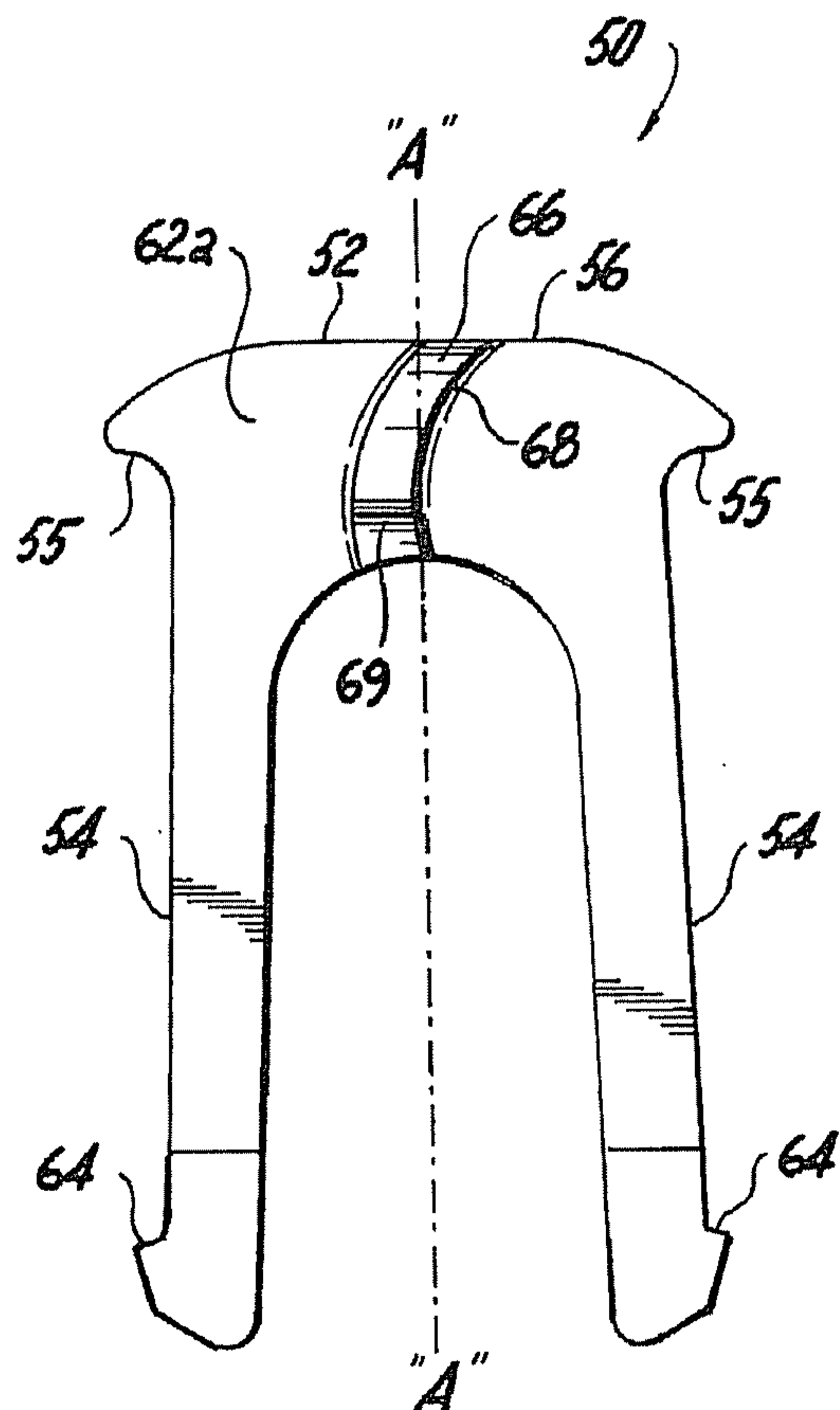
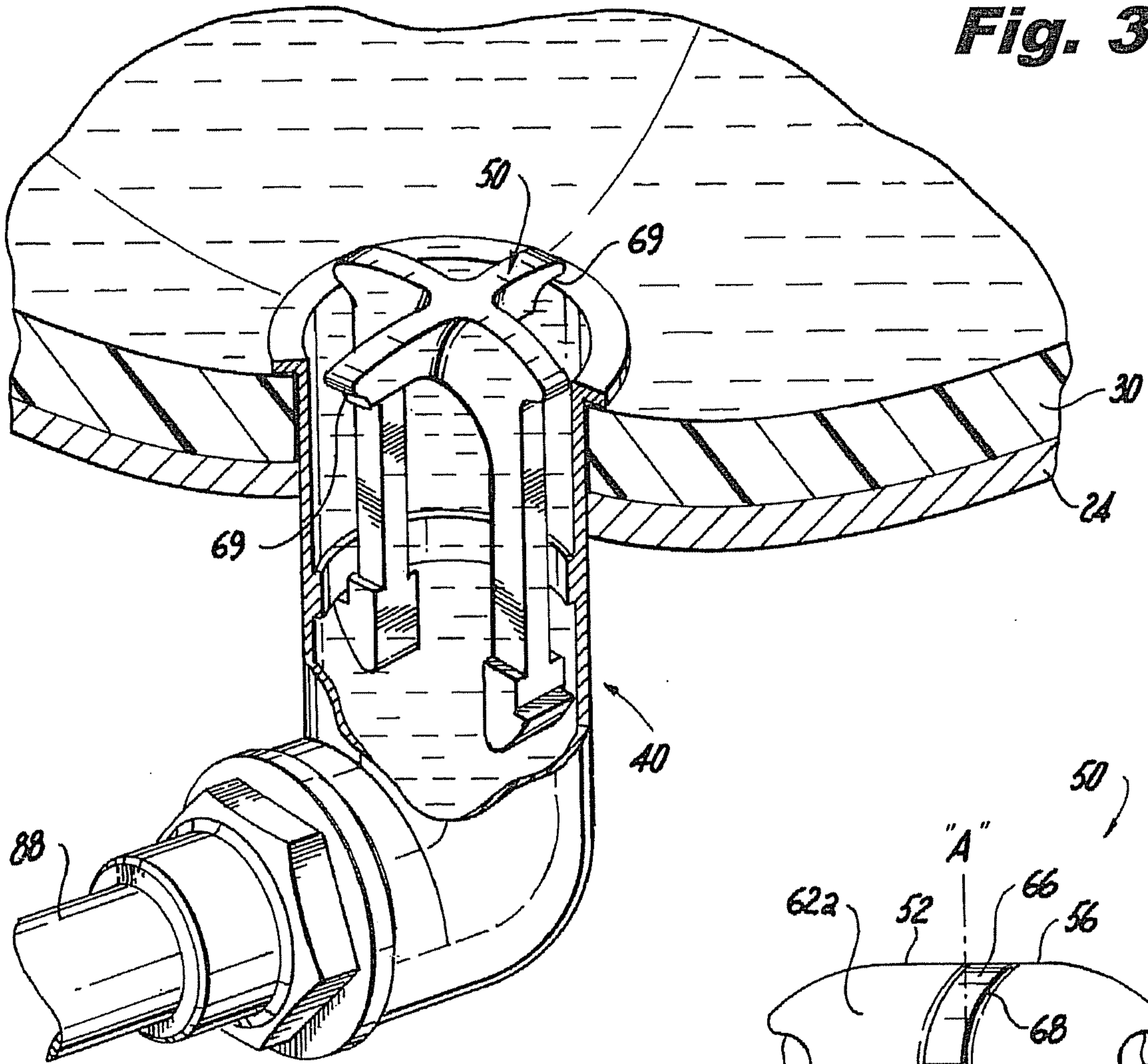

Fig. 4

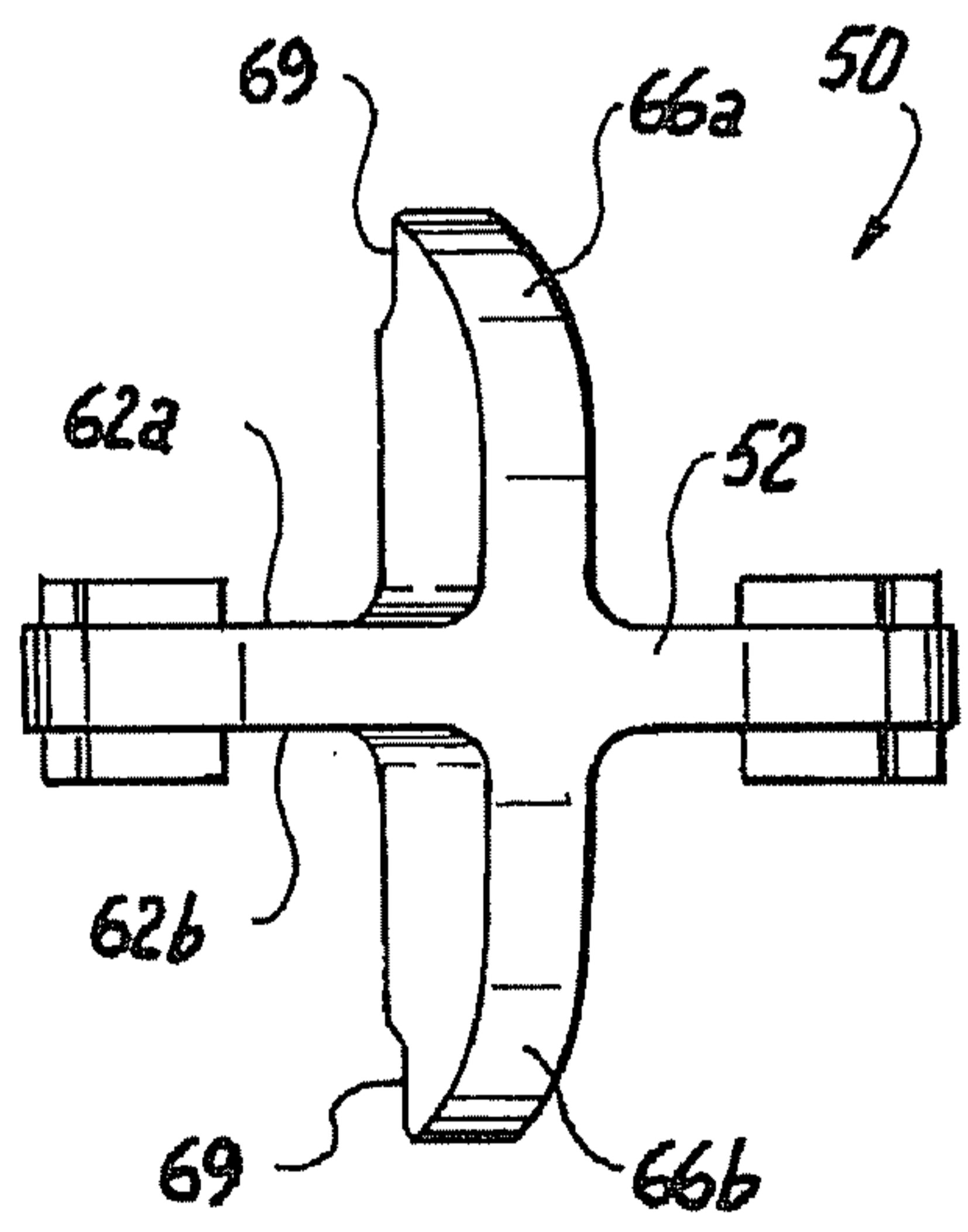

Fig. 5

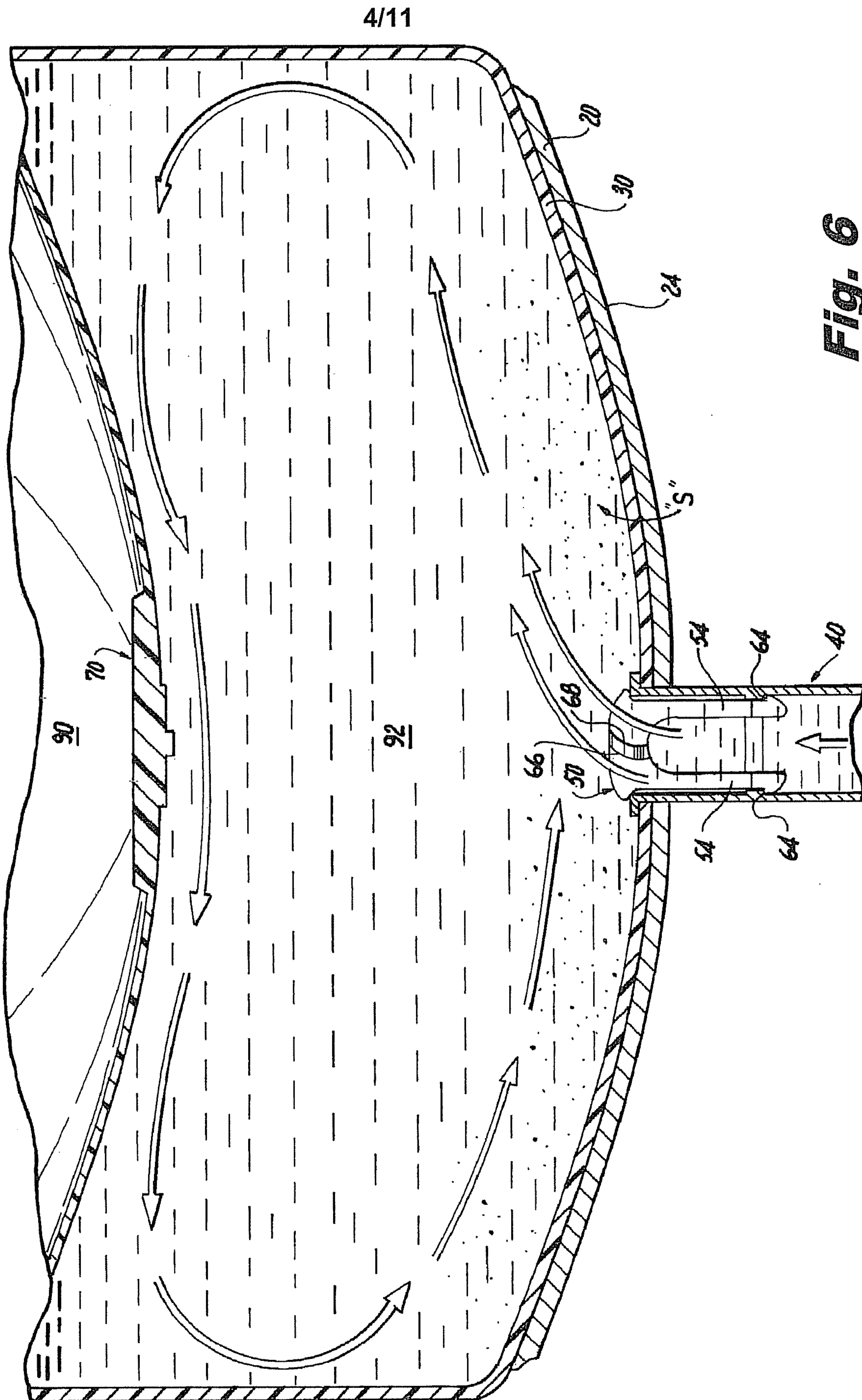

Fig. 6

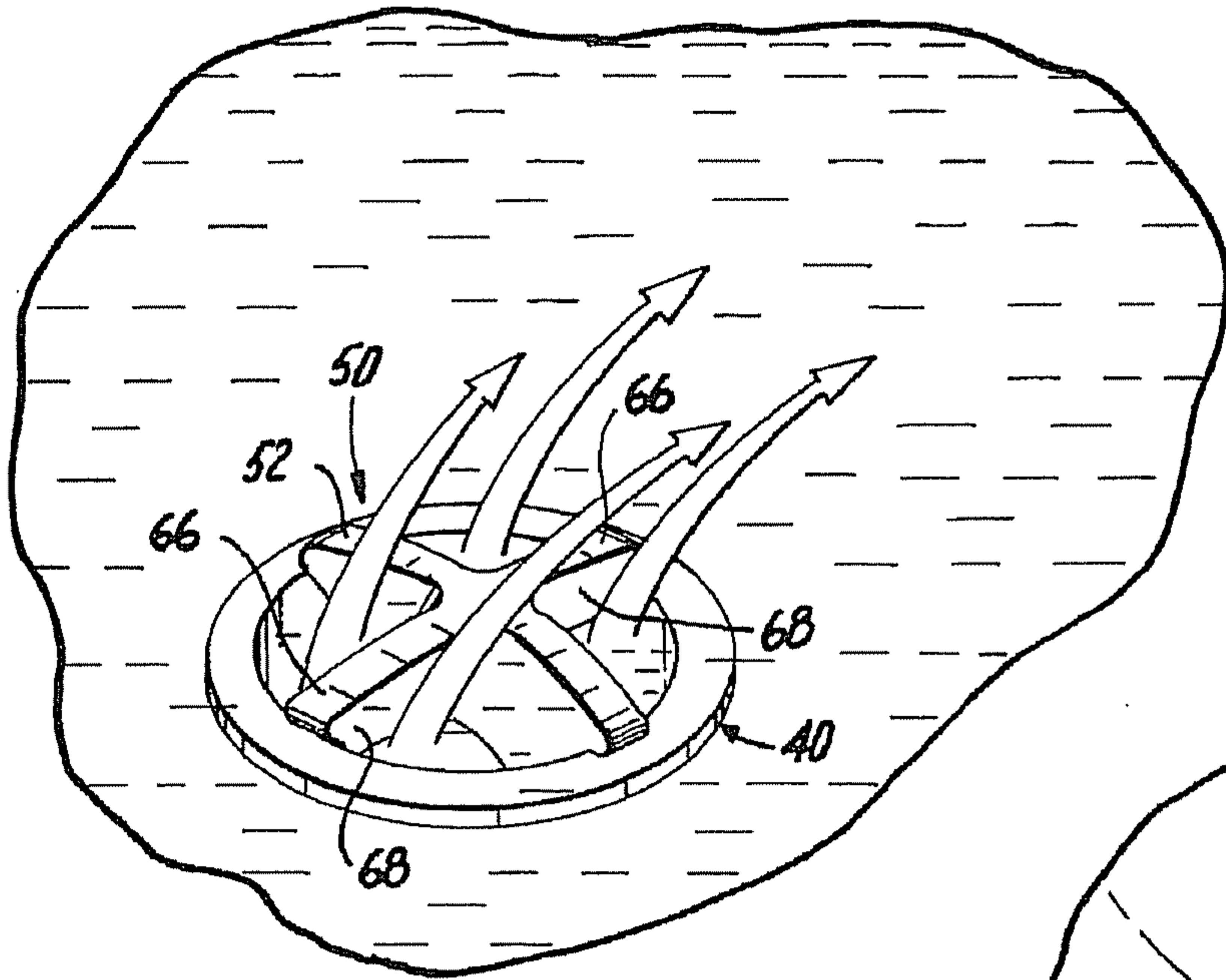

Fig. 7

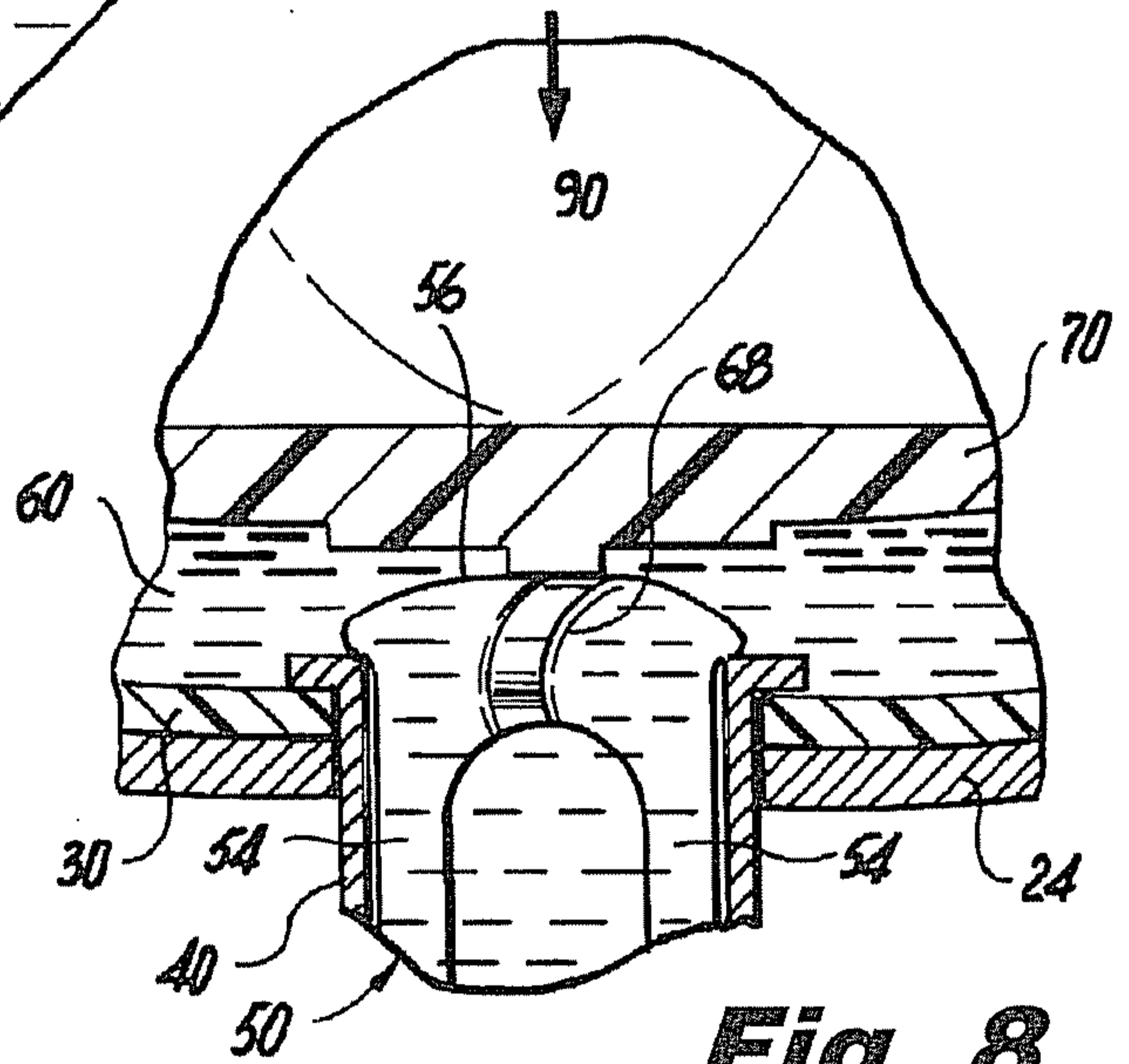

Fig. 8

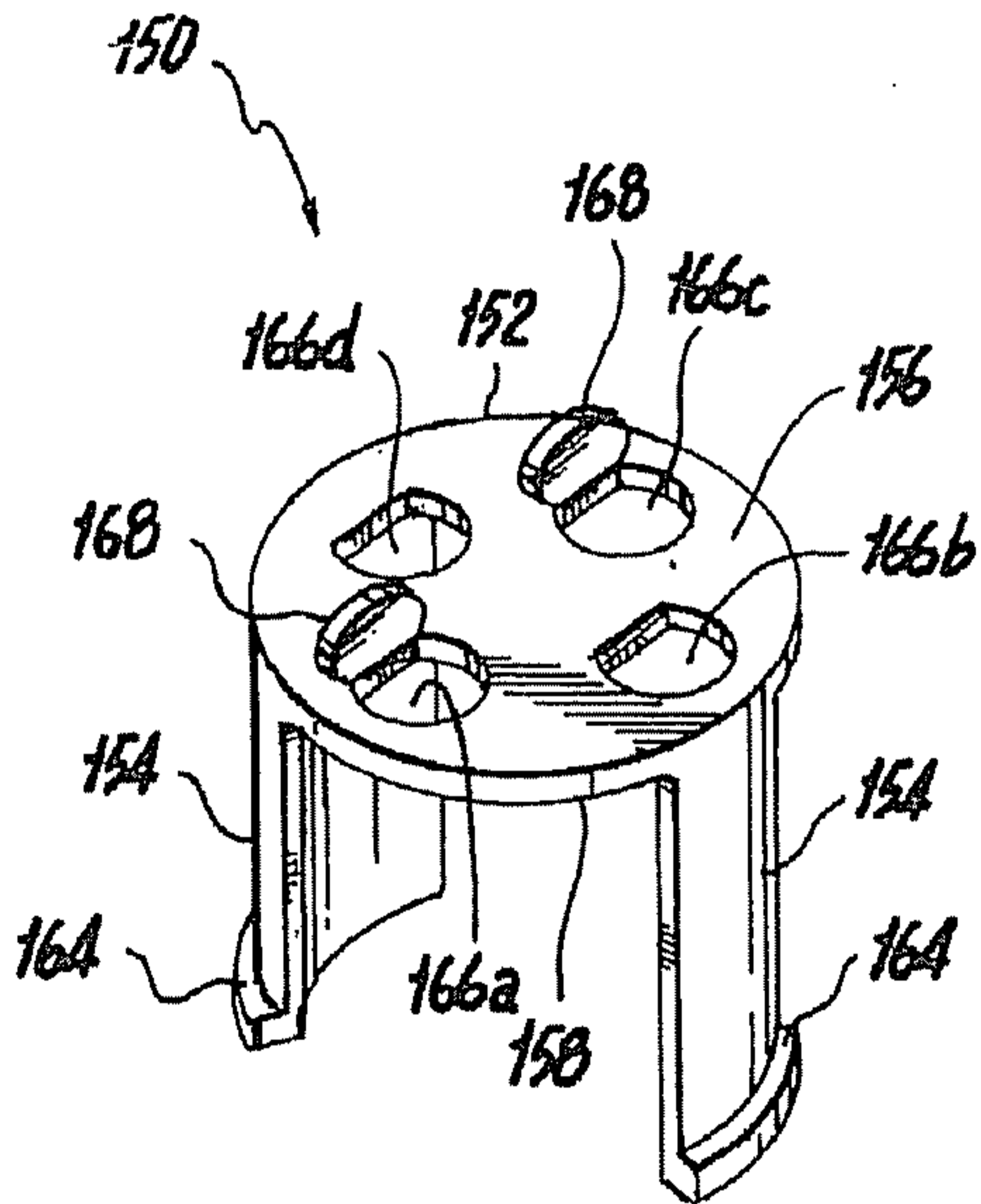

Fig. 9

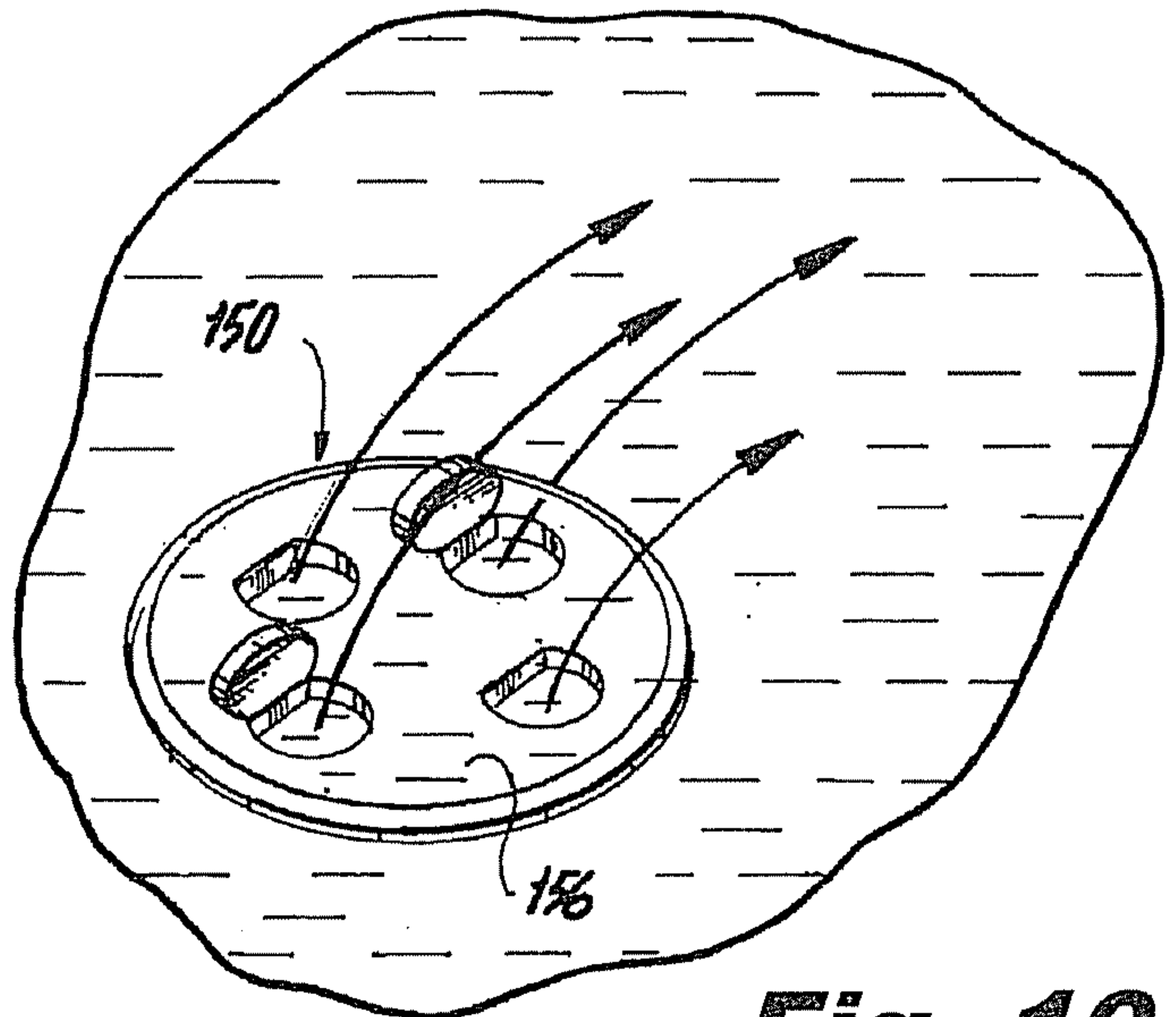

Fig. 10

Fig. 11

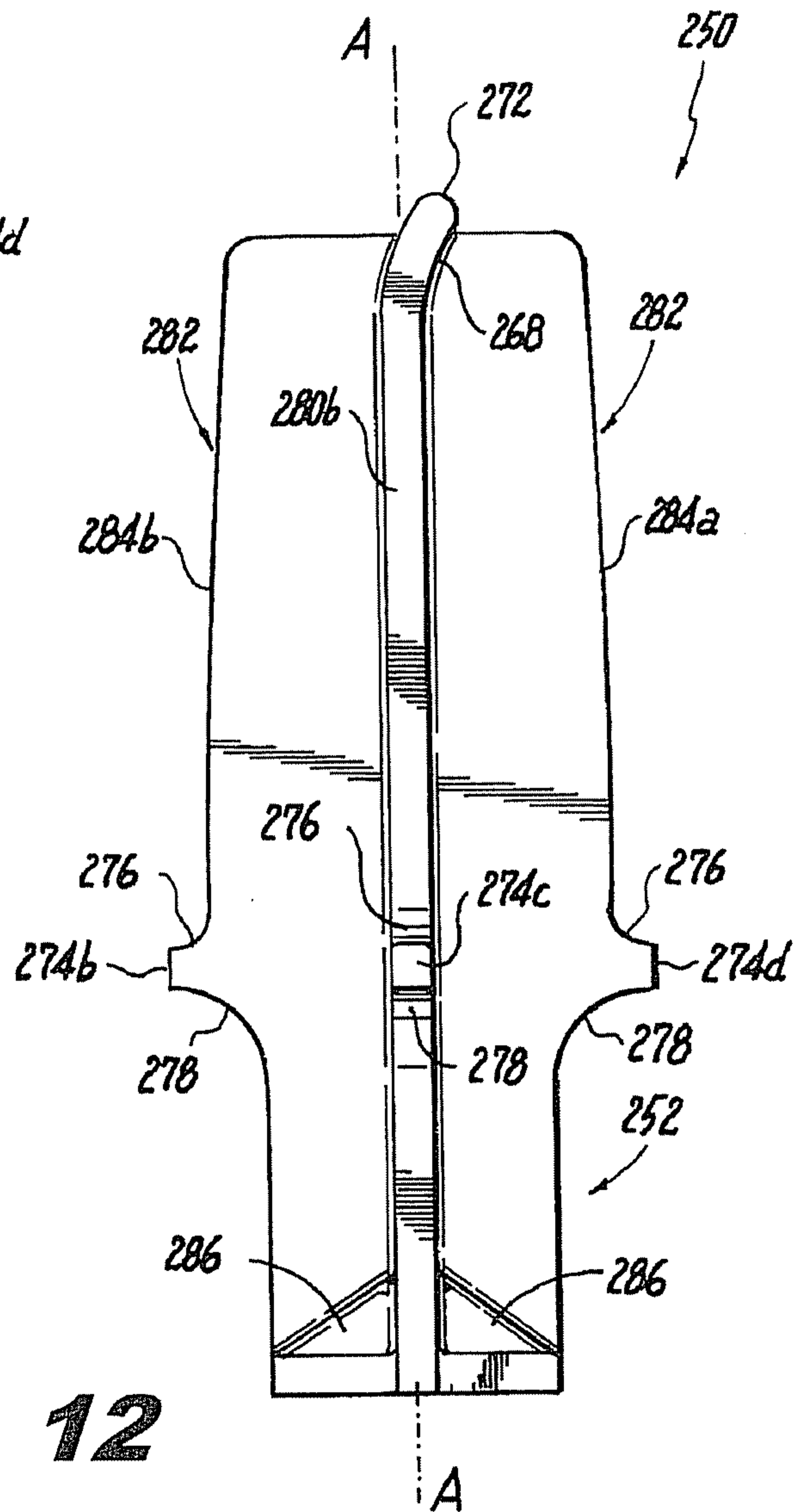
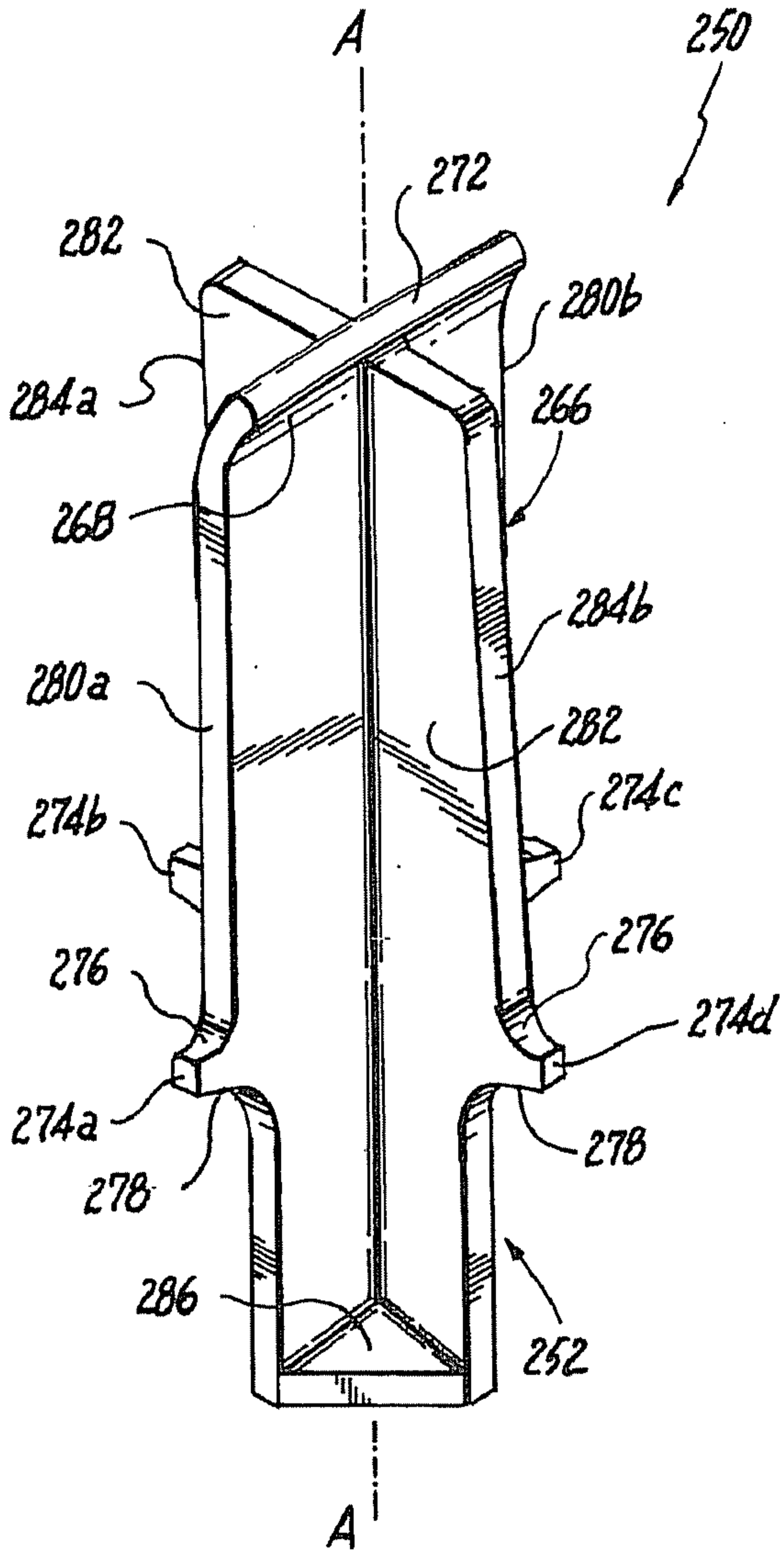
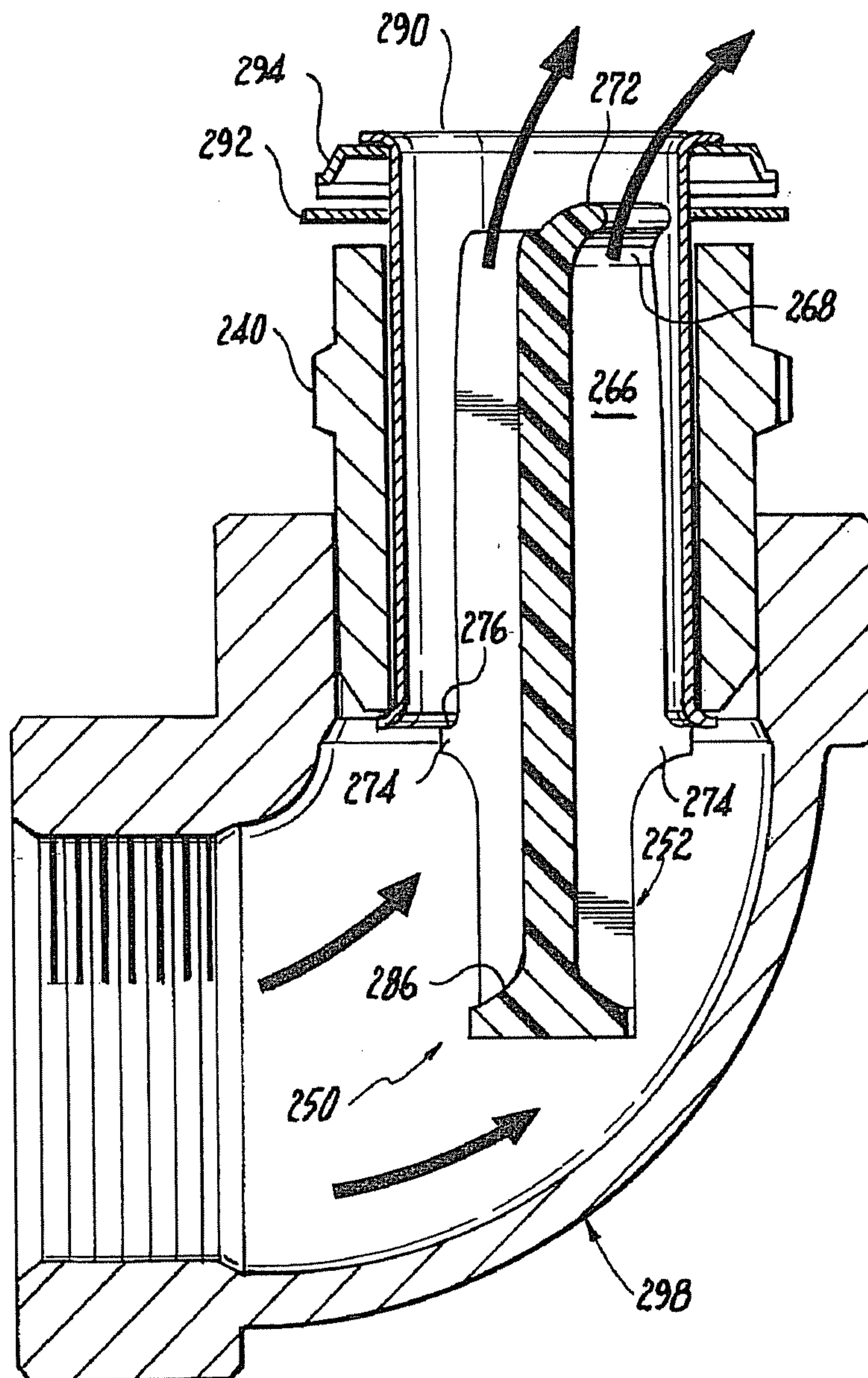

Fig. 12

7/11

Fig. 13



8/11

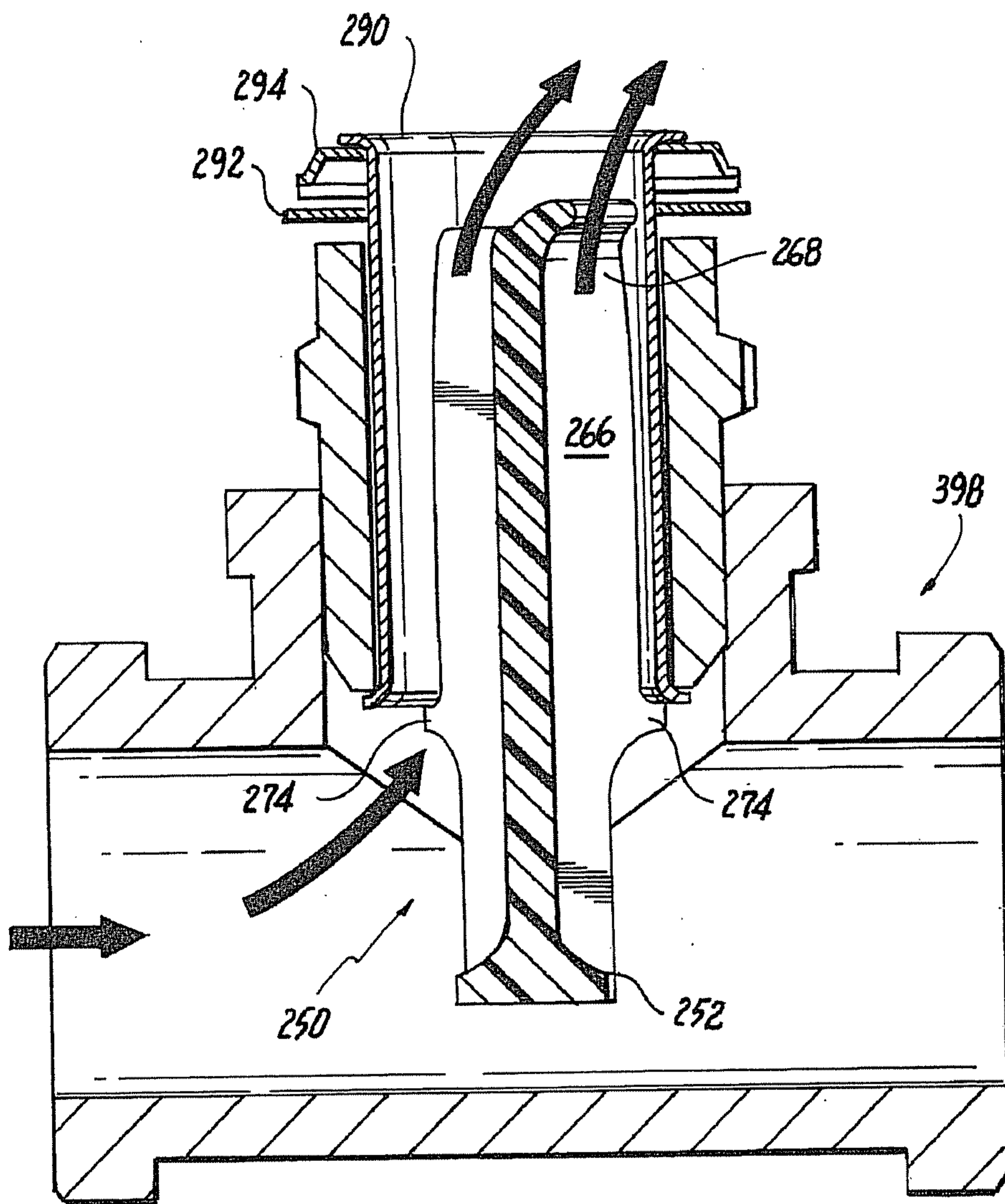

Fig. 14

9/11

Fig. 15a

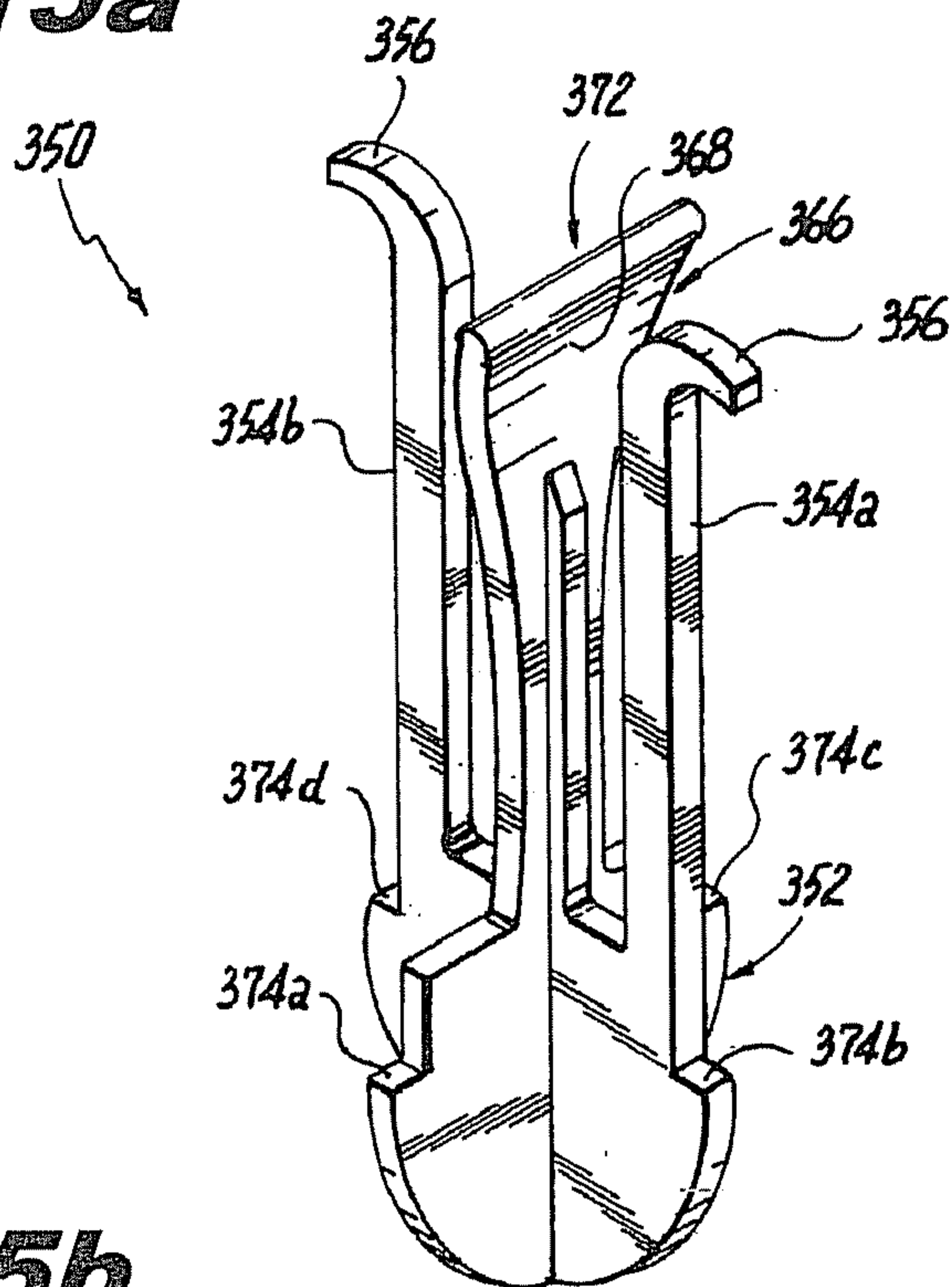

Fig. 15b

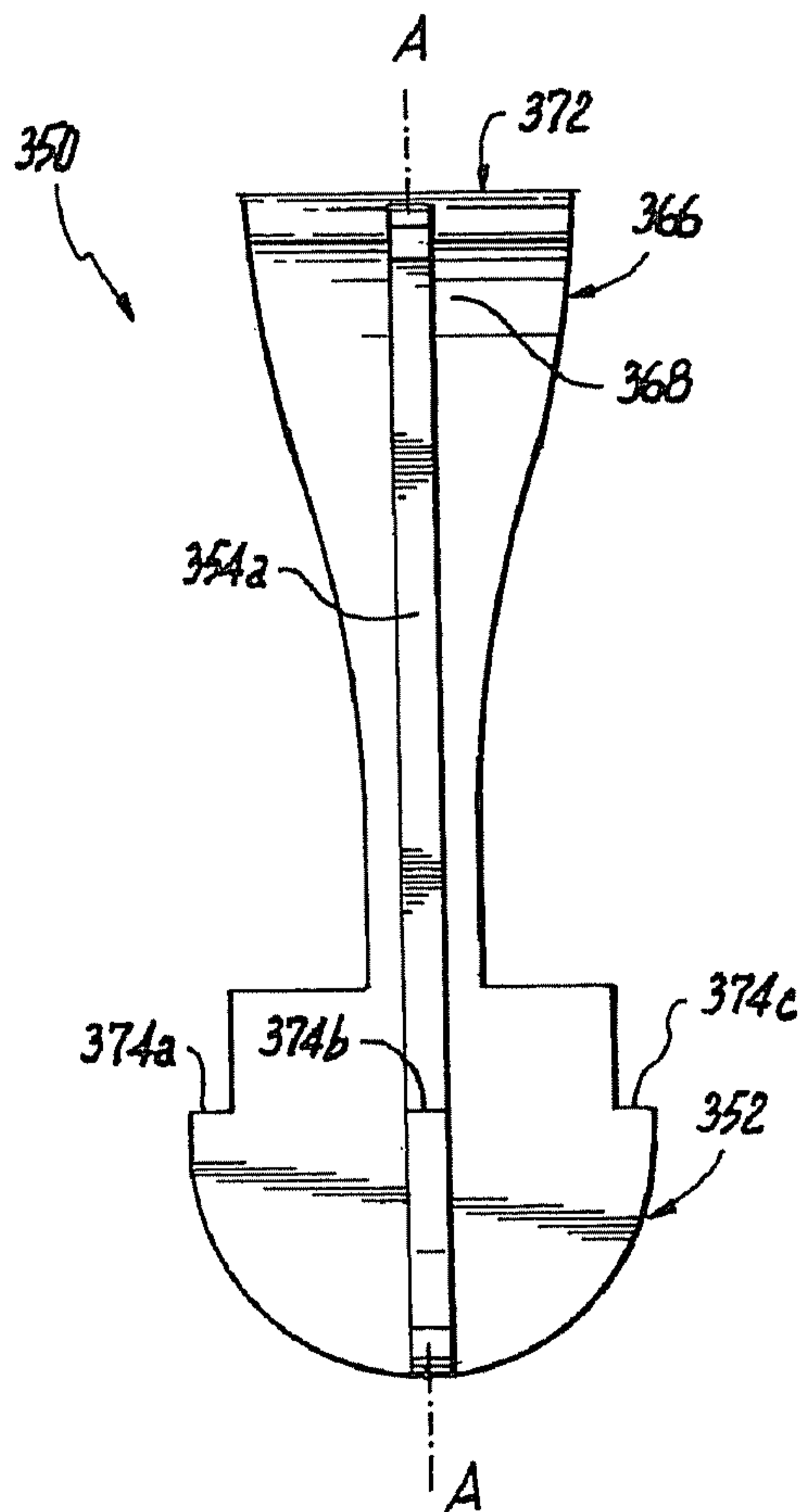
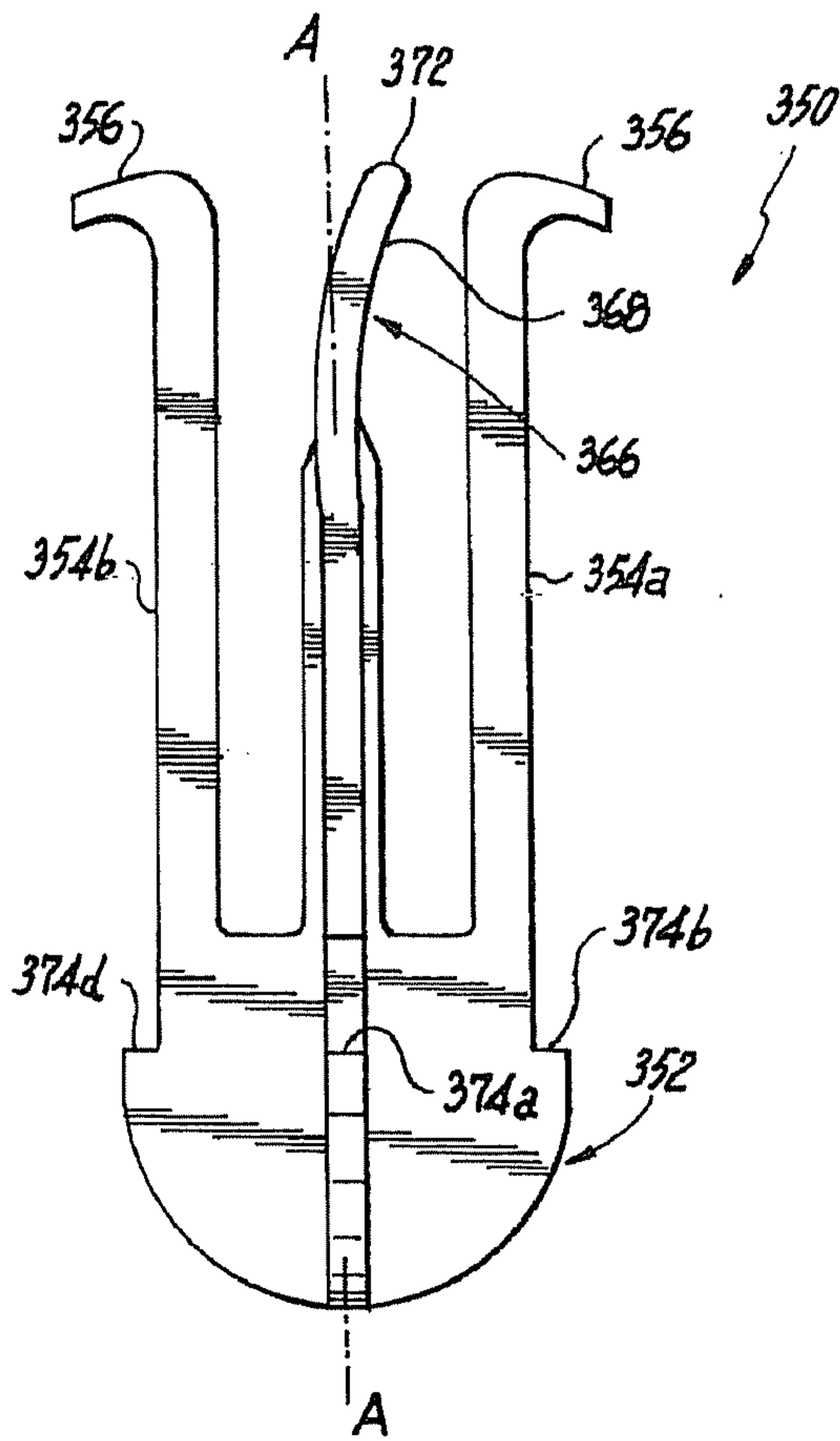

Fig. 15c



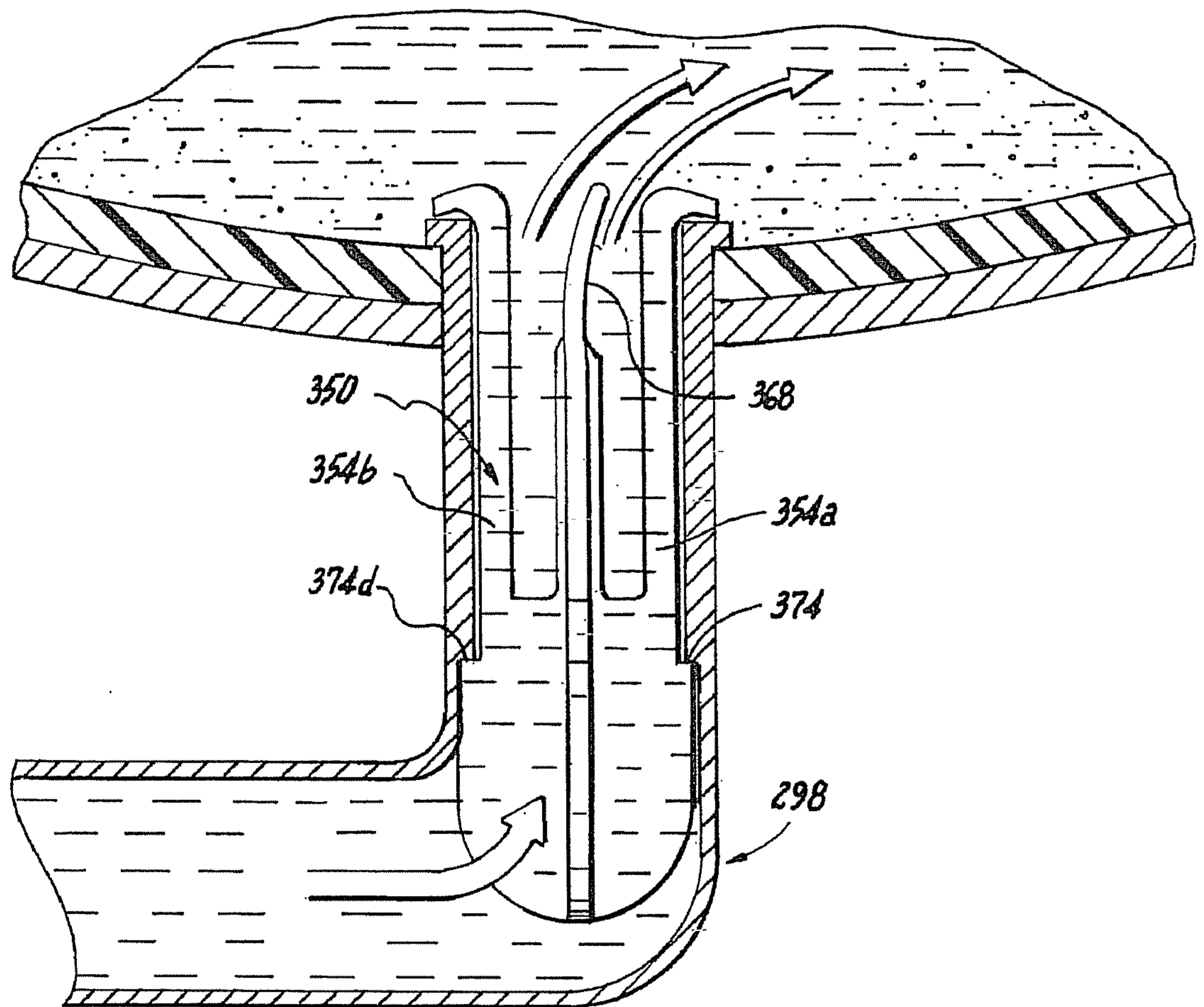

Fig. 16

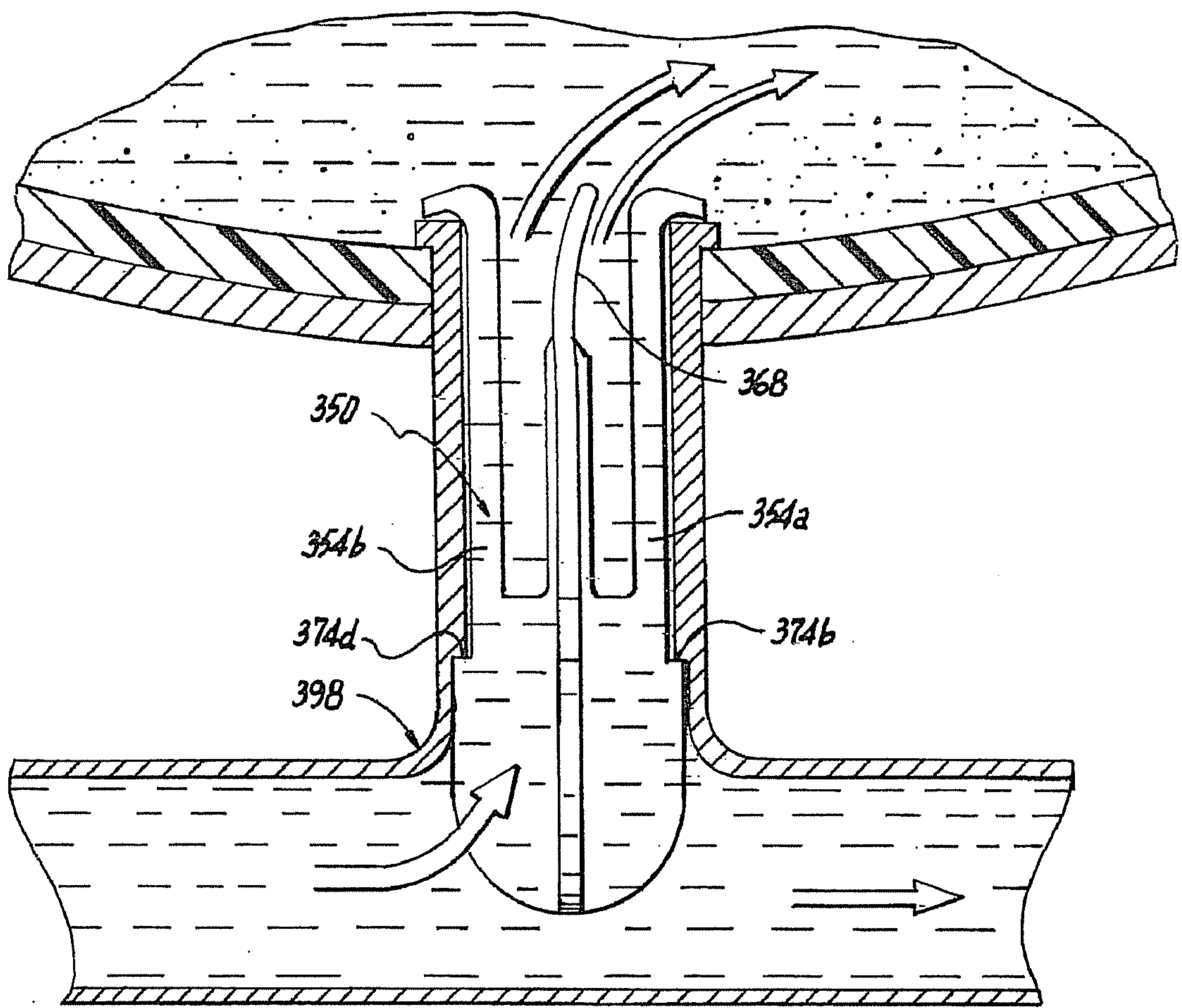

Fig. 17

