

Nov. 4, 1969

J. N. HURD

3,476,302

WALLBOARD ATTACHMENT AND APPARATUS THEREFOR

Filed May 13, 1966

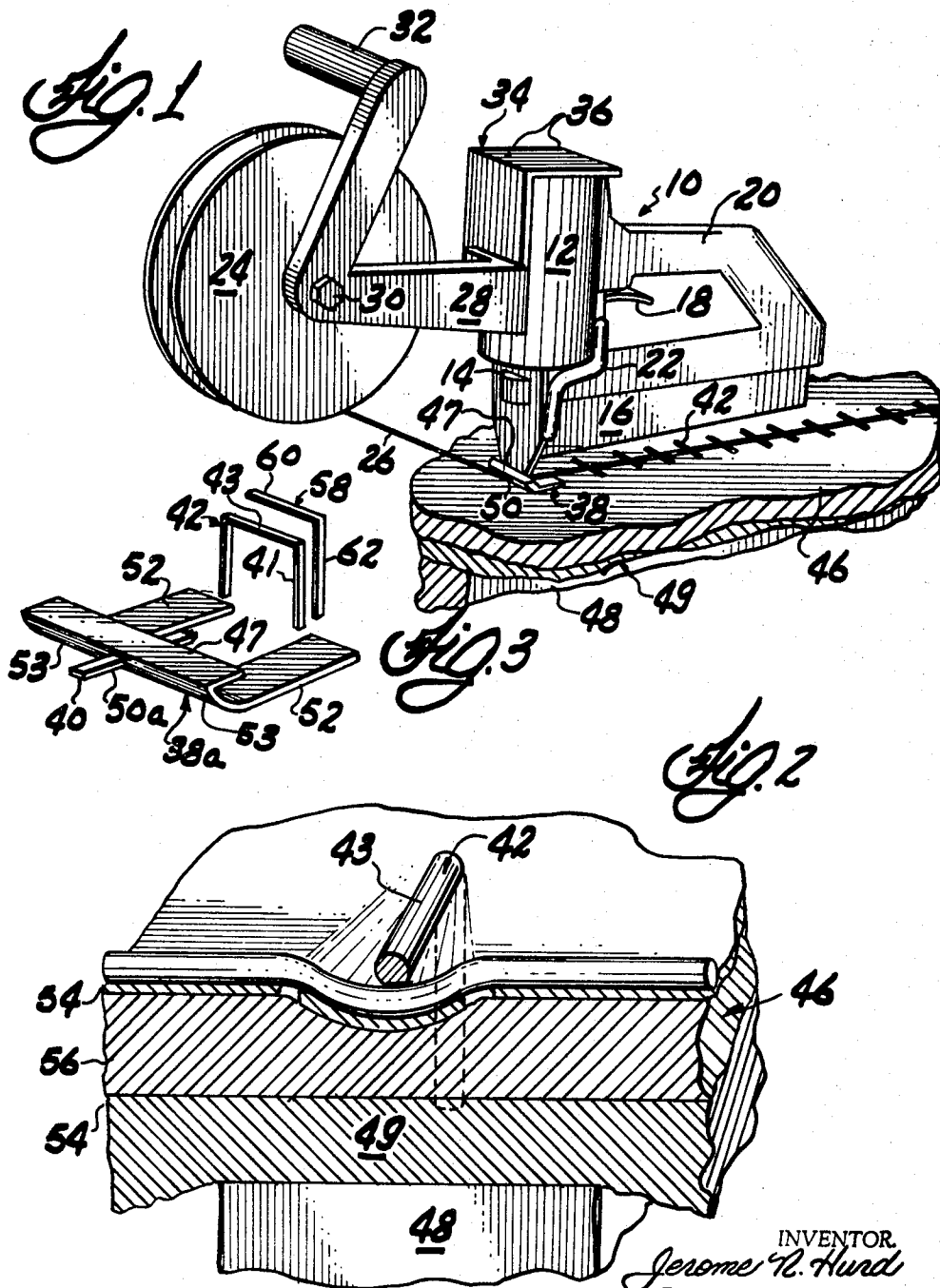

INVENTOR
Jerome N. Hurd
BY *Pendleton, Neuman*
Seibold & Williams
Attorneys

1

2

3,476,302

WALLBOARD ATTACHMENT AND APPARATUS THEREFOR

Jerome N. Hurd, Atlanta, Ga., assignor to United States Gypsum Company, Chicago, Ill., a corporation of Illinois

Filed May 13, 1966, Ser. No. 550,022
Int. Cl. B25c 5/06, 5/10, 5/16

U.S. Cl. 227-120

1 Claim

ABSTRACT OF THE DISCLOSURE

A portable stapler comprising a housing and reciprocally movable driving head, has a reel of wire mounted on said housing in a manner whereby wire is removed from such reel under tension. The taut wire is guided into the path of the reciprocating driving head. The bight portions of the driven staples engage the underlying wire with a regulated driving force adequate to deform the wire as the staple legs are driven into a penetrable base.

This invention relates to an improved method for attaching crushable board such as gypsum board to a supporting framework, and more particularly pertains to the attachment of such board to wooden supporting members by means of staples and similar type fasteners. This invention is also directed to apparatus for effecting the desired attachment.

The use of staples for securing gypsum board to a supporting framework has experienced limited success in the past. The use of staples for securing such board to wooden supporting members obviously expedites the fastening operation, as power-operated staplers are normally employed which merely require a slight trigger action by the operator to discharge a staple.

However, it has been found substantially impossible to apply each staple with the force necessary to drive the staple legs the optimum distance into the wooden support after penetrating the gypsum board. The application of too much force fractures the paper, and the bight of the applied staple penetrates the relatively soft gypsum core. Such fracture results in the loss of the board strength afforded by the paper. The resulting attachment will readily fail, particularly when the full weight of the board is supported by the staples as in a ceiling construction or in a suspended underflooring in a mobile home construction or the like. The application of too little driving force to the staple obviously would result in a loosely applied board and a defective attachment subject to early failure.

The difficulty in driving staples to equal depths into a supporting wood framework is occasioned by the non-uniformity always present in framing lumber. Differences in hardness in spaced sections of the same framework are due to a variety of reasons, among which are the irregular presence of knots and varying moisture content in the wooden members. It is substantially impossible, therefore, to adjust the power application to a stapling gun for purposes of attaining uniformity of staple penetration since adjacent sections of the same staple-anchoring member may vary greatly in hardness.

In accordance with this invention, it is an object to remedy the above defects of the prior art by providing a method of driving board-attaching staples into a wooden framework wherein a penetration-regulating means is employed. Such means serves not only to limit the distance the staples are driven into the framework but also affords additional support for the board member urged against the framework.

It is another object of this invention to provide a method for stapling gypsum board or similar crushable board in place on a wooden framework which allows the board applicator to utilize an overdriving force in the stapling gun with a minimum of board damage. Such force assures staple penetration of the hardest wood expected to be encountered in the framework, and the presence of an interposed regulating means between the staple and board assures the secure attachment of the board to the framework.

It is another object of this invention to provide a novel method for stapling thin gypsum board to a wooden framework without danger of attachment failure.

It is another object of this invention to provide novel stapler apparatus for carrying out the attaching method hereinafter described in greater detail.

In one embodiment of this invention, a common commercial stapler is provided with attachments enabling the desired stapling method to be carried out. The attachments comprise a reel for a coil of regulating wire mounted on the stapling head by means of a supporting bracket. The wire from the reel is passed through an axial opening in a slidable shoe member suitably affixed to lower terminal end portions of a staple guide as will also hereinafter be explained in greater detail.

The shoe positions the regulating wire so as to be disposed in the path of the driven staple, between the opposed staple legs and beneath substantially the center of the staple bight. The regulating wire reel preferably has a tension nut securing the same to the supporting bracket whereby the wire is drawn from the reel, taut, under a predetermined tension. The taut regulating wire functions as a stop means and allows penetration of the staple only to a desired degree into the underlying penetrable substrate comprising a gypsum or like board disposed over a board-supporting framework. The regulating wire enables a high staple-driving force to be applied which is in excess of that normally used to secure the board in place without danger of the board becoming loosened from the framework, particularly when subjected to vibration.

The regulating wire thus enables the staples to enter the wood framework to a desired degree only, and performs the second important function of serving as additional board-attaching means between the spaced staples.

For a more complete understanding of this invention, reference will now be made to the drawing wherein:

FIGURE 1 is a fragmentary perspective view of a power stapler member incorporating novel structural features made in accordance with this invention illustrated in the process of securing a thin board member to a supporting frame member with a glass mat positioned therebetween in accordance with the method hereinafter to be described in greater detail;

FIG. 2 is a fragmentary perspective view, partly in section, illustrated on an enlarged scale, of a fastening means in overlying relationship with a regulating wire employed to limit the penetration of the fastening means into a penetrable frame member after first piercing an overlying board member; and

FIG. 3 is a fragmentary perspective view illustrated on an enlarged scale of a guide means which may be employed in the stapler construction of FIG. 1, said guide means being illustrated in a position of use with a regulating strip of noncircular cross-sectional configuration; FIG. 3 also illustrates the normal relative position between typical fastening means which may be employed in the provided method and the guide means prior to embedment of the fastening means in an underlying base member.

Referring now more particularly to FIG. 1, a power-operated stapler construction 10 is illustrated which is of

a type well known in the art. The illustrated stapler which is suitable for use in the method hereinafter described is an MI model manufactured by Senco Products, Inc., Cincinnati, Ohio. Inasmuch as the specific power-operated stapler to be employed in the method hereinafter described comprises no part of this invention, although the attachments thereto provided by this disclosure are believed to be patentably novel, the stapler per se will not be described in great detail.

It will be noted from FIG. 1 that the stapler 10 employs a cylindrical head portion 12 in which a reciprocally movable piston member may drive a staple-driving element during the piston downstroke (neither the piston nor element is illustrated). The staple is guided in the course of its downward movement by means of a vertically disposed guide element 14 extending from the bottom of the stapler cylindrical portion 12.

The vertical guide 14 is hollow to allow movement therein of the driven staple members which are first laterally movable from staple housing portion 16 into alignment with the driving blade moving within the guide 14. The driving force for the piston within the cylinder 12 may be compressed air, although other fluid media and power means may be employed. The driving blade within the cylinder and which is movable in the guide 14 may be readily actuated by means of trigger 18 which is engageable with a finger of the staple applicator while the trigger hand engages upper handle portion 20 of the stapler.

Secured to guide 14 of the stapler and movable therewith are opposed substantially S-shaped arms 22, only one of which is seen in FIG. 1. Guide 14 is telescopically movable relative to cylindrical portion 12 in the normal course of stapler use. Such movement enables the upper end portions of the arms 22 to simultaneously open an air valve when the movement is caused by the lower end of the guide 14 resting upon or being urged against a surface to be penetrated by a staple member. This allowable movement of the guide 14 and arms 22 therefore constitutes a safety feature. Until the safety valve is opened by upward movement of the guide 14 and movement of arms 22 relative to the cylindrical portion 12 of the stapler, no staple-driving action is allowed to take place. Accordingly, a staple cannot be discharged until the stapler engages a supporting surface.

The foregoing elements comprise the main structural features of a well-known stapler construction. In accordance with this invention, means are provided for mounting and positioning an elongate, hard, flexible strip beneath the central portion of the staple bight prior to actuation of the stapler and the driving of the staple into the members adapted to be joined thereby.

As above indicated, difficulty had previously been experienced in the use of power-actuated staplers when such staplers were employed to secure crushable boards to supporting frame members. Thus, in the mobile home industry, underfloorings suspended on the home bottoms were formerly made of fiber-type boards, that is, boards made by wet forming and drying a mat fabricated from coarse wood fiber pulp. Because of the undesirable crushing which normally took place when power-operated staplers were employed with gypsum board, the latter board was previously found unsatisfactory for this particular use. The power with which staples were driven into the supporting wooden frame would normally crush the gypsum core to such an extent after tearing of the paper facing that the resulting attachment was defective and subject to early failure.

By the insertion of a regulating wire or strip between the bight of the staple and the surface of the board to be attached to the wooden frame member, the distance that a staple may be driven into the crushable core is limited. Consequently, applicators are now able to employ a staple driving force heretofore impossible to use if crushable boards were to be secured to a frame member.

To facilitate the desired positioning of a regulating strip

between the staple and crushable board, the stapler attachments illustrated in FIG. 1 may be utilized. Reel 24 comprises a means whereby a flexible regulating wire 26 may be disposed adjacent to the stapler cylindrical portion 12 and readily dispensed beneath the driven staples in the course of board attachment.

The reel 24 is rotatably mounted on a bracket member 28 to which the reel is connected with the assistance of a tension nut 30. The upper end of bracket 28 has a handle member 32 secured thereto which extends at substantially right angles to the normal plane of the reel. Bracket 28 may be formed integrally or suitably attached by welding or the like with one leg of an L-shaped mounting member 34. The other leg of the mounting member is secured by screws 36 or other equivalent means to the upper end portion of cylindrical portion 12 of the stapler 10.

In addition to a means for rendering a supply of regulating wire readily accessible to the stapler, a guide means comprising shoe 38 is employed. Shoe 38 guides the passage of the wire 26 from the reel 24 to a desired location beneath substantially the central portion of the stapler guide 14 thereby assuring contact between substantially the center of the bight portions of the driven staples 42 and the regulating wire 26.

FIG. 1 illustrates the power-operated stapler 10 in the course of stapling a thin gypsum board 46 to a wooden joist 48. In the normal mobile home construction, joists 48 are placed on 16 inch centers, and after the home floor has been formed over the joists, the floor is inverted to facilitate application of the underflooring boards normally referred to as "chassis" board. In order to maintain the weight of the mobile home at a minimum, a desirable gypsum board employed as a chassis board need only be approximately 1/4 inch thick. Such board is rendered water-resistant by appropriate treatment of the paper facing and by the employment of a special, set calcined gypsum core. A light weight glass fiber mat 49 is placed between the board 46 and joists 48 for insulation purposes. A blanket 1 inch in thickness has been found satisfactory; such blanket is compressed to about a 1/4 inch thickness after the board is secured in place to the joists.

The shoe 38 of stapler 10, more clearly seen in FIG. 1, is welded or otherwise suitably secured by means of transverse connection portion 47 to a lower end portion of staple guide 14. Transverse portion 47 of shoe 38 is centrally apertured at 50 to permit passage of the desired regulating wire 26 in the manner illustrated in FIG. 1. Whereas the opening 50 is circular in FIG. 1 to permit passage of wire 26, opening 50a of shoe 38a illustrated in FIG. 3 is noncircular to conform with the cross-sectional configuration of strip 40. Also comprising portions of the shoes 38 of FIG. 1 and 38a of FIG. 3 are opposed foot portions 52 having curved connecting proximal portions 53 joined to the transverse portion 47. The curved connecting portions facilitate slidable movement of the opposed feet over the surface of the board 46 in the course of effecting the stapling action indicated in FIG. 1. During stapler use, the end portion of the stapler holder 16 oppositely disposed to the stapler cylindrical portion 12 may also rest upon the board surface to facilitate the stapling operation.

In the course of effecting a desired board attachment to a wooden frame member, a first staple is driven through the board and into the wooden frame with one end portion of a regulating wire or ribbon interposed between the staple bight and the upper surface of the board. After the first staple application, the entire stapler assembly is slidably moved, with the assistance of the handle portions 20 and 32, along substantially the central longitudinal axis of the frame member 48. While so moving, the wire 26 is withdrawn in a taut condition from the reel 24 inasmuch as the turning of the reel 24 is controlled by the tension nut 30. The guide shoe 38 properly positions the wires so that the same may be desirably centered beneath the bight of the staples which are applied at desired intervals in the manner illustrated in FIG. 1.

5

It will be noted from FIG. 2 that each staple 42 is driven with such force as to downwardly deform the regulating wire 26 in the immediate vicinity of contact between the staple and wire. The only portion of the applied board 46 which is crushed, however, is that small portion of core 56 surrounding bight portion 43 of the fastener shown in section in FIG. 2.

It will also be seen from FIG. 2 that the portions of the wire 26 extending between the staples 42 do not crush the board core or fracture paper surface 54. It is apparent that simultaneously with the deformation of the wire 26 by the staple bight, additional tautness is imparted to the wire 26. It is further apparent that the illustrated board 46 is retained to the wooden frame member 48 not merely by the spaced staple members alone, but is supported along its entire length by the wire 26 which retains the board against the frame member 48 in cooperation with staples 42.

As is above indicated, variations may be made in the process above disclosed. In addition to the employment of well-known staples 42 having opposed leg portions 41 connected by a transverse bight portion 43, fastener members such as L-shaped fasteners 58, shown in FIG. 3, may be employed; the latter fasteners employ a bight portion 60, similar to bight 43, which is secured to a single leg member 62.

Still other fastener shapes may be employed such as T-shaped fasteners in which opposed arm portions of the cross member may be used in conjunction with two spaced, parallel regulating wires or ribbons. As has already been pointed out, the specific cross-sectional configuration of the regulating means which limits the penetration of the staple bight into the crushable core is of no great significance. Also, the regulating wires or strips may be formed of tough plastic as well as metal.

Suitable staples for use with the Senco Products stapler above referred to are Senco staples bearing the identifying number G5562-112 which are made of No. 16 gauge wire. Obviously, other staplers and other staples may be employed. Staples made of No. 19 gauge wire have been found satisfactory although other sizes of wire may be employed such as No. 14 or No. 24 and intermediate sizes, depending upon the specific attaching operation to be carried out.

As is apparent from the nature of the attachment above described, this method has particular application in those constructions in which the secured board member has its entire weight supported by the attaching means. Consequently, the above-described attaching system may be used to particular advantage in ceiling constructions and in underflooring, as above indicated, in the mobile home industry where the attached boards are not resting on a supporting surface. The described method of attachment may, of course, be employed for securing floor members disposed over supporting joists and vertical wall members secured to supporting frames. This invention also has particular application to the use of boards having crushable cores or which are made entirely of crushable compositions. By "crushable" is meant that the application of a commercial staple with ordinary driving force will result in crushing of the board at least in the vicinity of the applied staple member.

The supporting frame members on which the boards are mounted may be of any material which is penetrable by the driven staples and which will anchor such staples. The described method desirably employs a staple-driving force which will deform the regulating wire in the manner illustrated in FIG. 2 as well as the underlying surface portion of the board member attached, to assure the imparting of additional tension along the length of the wire 26. The entire wire length of the resulting structure serves to secure the board to the frame member.

Utilizing the above-identified stapler construction and preferred stapler members, it has been found that an air pressure of from about 65 to 85 p.s.i. functions most

6

satisfactorily in effecting the attachment of a ¼ inch gypsum board to a wooden frame member with the assistance of an 18 gauge regulating wire.

A number of tests were conducted for purposes of ascertaining the relative holding power of nails, power-driven staples, and power-driven staples when utilized with a continuous regulating wire extending between the staples, beneath the staple bights.

Each test specimen consisted of a 4 x 20 inch section of ¼ inch gypsum chassis board attached by three fasteners to the nominal 2 inch edge surface of a 20 inch length of two-by-four with the central longitudinal axes of the board and two-by-four in superposed relationship. Each series of fasteners tested was applied on 8 inch centers with the end fasteners spaced 2 inches from the board ends and the center fastener at the precise center of the chassis board.

The fasteners tested included ring shank dry wall nails manufactured by the Northwestern Steel and Wire Co. of Sterling, Ill. The nails were 1¼ inches long with heads of ⅝ diameter. The nail shank was 13 gauge and had the bottom ¼ inch thereof ringed. The staples tested were 1½ inches long with a ⅜ inch bight and formed of 16 gauge wire. The regulating wire employed in the tests was 18 gauge.

Each assembly of chassis board and two-by-four retained together by a series of three fasteners was placed for test in a holder which maintained the assembly in the horizontal plane with the chassis board lowermost. The holder retained each assembly elevated by means of steel rods traversing rod-receiving apertures in the two-by-four thickness. The spaced rods defined the ends of the central third of the assembly length and the centers thereof were accordingly spaced inwardly from each end of the assembly 6½ inches. The rods were supported at opposite ends by vertical standards whereby the chassis board was suspended from the two-by-four bottom edge and able to be forced from said edge by a test force pushing the board downwardly.

A wooden yoke comprising a U-shaped member having opposed legs 9 inches high, each with a cross section of 1¼ inches by 1½ inches, and joined by a bight 4¼ inches by 1½ inches straddled the two-by-four with the leg ends thereof resting on the opposed board portions adjacent the center fastener. The wooden yoke of each test assembly was loaded in a Tinius-Olsen Electromatic Universal Testing Machine at a rate of 0.5 inch per minute until failure of the center attachment occurred as the board was pushed from the two-by-four as evidenced by a maximum machine reading.

The subjoined table dramatically illustrates the superior holding power of a staple-regulating wire assembly to that of either nails or staples when employed as fasteners in the structural systems described.

TABLE

Fastener	Push-Off Force, lbs.	Average Pounds
1 Gypsum Wallboard nails.....	70.7, 55.6, 75.4, 60.0, 76.5	67.6
2 Power applied staples. Staples contacting but not breaking paper (45 lb./in. ² air on staple).	37.1, 43.7	40.4
3 Same as 2, but a continuous retarding wire is applied between the bight of each staple and the board.	* 61.8, 62.7	62.3
4 Staple bight forced into the board so as to break the paper and become embedded in the core (65 lb./in. ² air on staple).	20.8, 23.6	22.2
5 Same as 4, but a continuous retarding wire is applied between the bight of each staple and the board.	75.6, 75.6	75.6

* Staple pulled out of two-by-four. All other failures occurred with the nail or staple cutting through the board.

Fasteners 2 through 5 were tested twice while the nails comprising fastener No. 1 of the above table were

tested five times to arrive at a more revealing average. The nails were driven into the specimens so that the heads were sunk below the plane of the board without fracturing the paper in the normal manner. The rather large variance in the push-off forces employed with the nails was due to the inability to manually drive each nail into the two-by-four framing member with exactly the same force to the maximum depth at which the board paper was not broken.

It is apparent from the table that by employing a regulating wire, the average push-off force necessary for attachment failure increased 54 percent when a staple-driving pressure of 45 lb./in.² was employed and increased 240 percent with a staple-driving pressure of 65 lb./in.² even though the staple is driven below the paper surface. The latter figure clearly indicates that the high 65 lb./in.² staple-driving pressure which obviously crushed the board to the extent that the attachment failed at the relatively low average force of 22.2 pounds when no retarding wire was employed, provided a superior fastener construction when employed in accordance with the method of this application utilizing such a wire.

The use of the provided regulating wire is of still greater importance when employed in the construction of floors such as illustrated in the drawing in which a resilient mat is placed between the board and framework. Such resilient intermediate layer magnifies the tendency for staples or nails to shear through the gypsum board resulting in defective attachments. Consequently the desirability of using the described retaining means is even greater with such structural arrangements.

Without further elaboration, the foregoing will so fully explain the character of my invention that others may, by applying current knowledge, readily adapt the same for use under varying conditions of service, while retaining certain features which may properly be said to constitute the essential items of novelty involved, which items are intended to be defined and secured to me by the following claim.

I claim:

1. In a portable, hand-engaging stapler apparatus, the combination comprising a housing, a staple guide, a reciprocally movable driving head adapted to drive staples having at least one leg joined at substantially right angles

to a bight portion, with predetermined force along said guide into a penetrable base adapted to receive such staples; a rotatable reel mounted on said housing for purposes of dispensing a stop wire in the path of the reciprocating driving head and in the path of the bight portions of staples driven thereby, means supported by said stapler housing for guiding said stop wire into said path, said means comprising a shoe having a base portion extending beneath the driving head and a curved end portion disposed in a normal direction of the stapler movement; said base portion comprising spaced foot portions connected to said curved end portion adapted to facilitate slidable movement of the stapler over such penetrable base; said shoe curved end portion having a wire-receiving aperture disposed along an axis intermediate said foot portions and in alignment with said reel and said driving head, said axis being disposed so as to be traversed by substantially the centers of said staple bight portions in the course of being driven by said driving head, and means for controlling the driving force applied to said driving head whereby the stop wire portions engaged by the staple bights are slightly deformed into the surface of the penetrable base in the normal course of stapler operation without fracturing such surface.

References Cited

UNITED STATES PATENTS

3,122,749	3/1964	Abrams	227—120
2,156,165	4/1939	Sims	227—89
3,283,986	11/1966	McKee	227—120
2,637,030	5/1953	Wickman et al.	227—151
3,310,215	3/1967	Bostick	227—12
3,319,864	5/1967	Adams	227—76
815,197	3/1906	Miller	227—46
1,291,071	1/1919	Miller	227—46
913,958	3/1909	Inwood	227—46

THERON E. CONDON, Primary Examiner

HORACE M. CULVER, Assistant Examiner

U.S. Cl. X.R.

227—46

UNITED STATES PATENT OFFICE
CERTIFICATE OF CORRECTION

Patent No. 3,476,302

November 4, 1969

Jerome N. Hurd

It is certified that error appears in the above identified patent and that said Letters Patent are hereby corrected as shown below:

Column 4, line 43, "connection" should read -- connecting --; line 73, "wires" should read -- wire --.
Column 5, line 74, "stapler" should read -- staple --. Column 6, line 42, "1-5/6" should read -- 1-5/8 --; line 43, "1-5/6" should read -- 1-5/8 --; line 63, "bright" should read -- bight --.

Signed and sealed this 9th day of June 1970.

(SEAL)

Attest:

Edward M. Fletcher, Jr.

Attesting Officer

WILLIAM E. SCHUYLER, JR.

Commissioner of Patents