

(No Model.)

A. V. SMITH.
THILL COUPLING.

No. 414,260.

Patented Nov. 5, 1889.

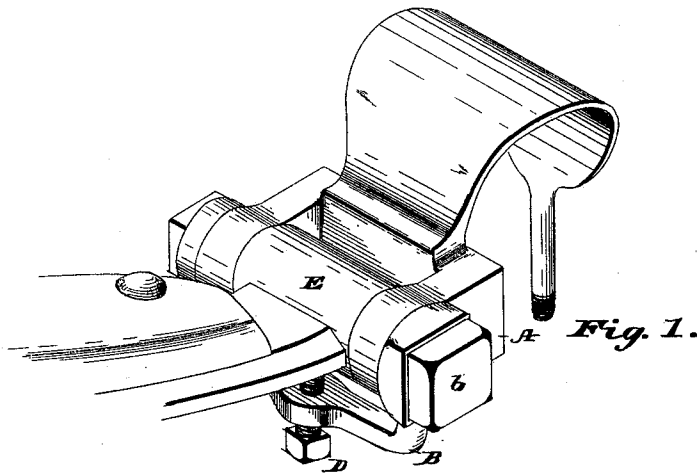

Fig. 1.

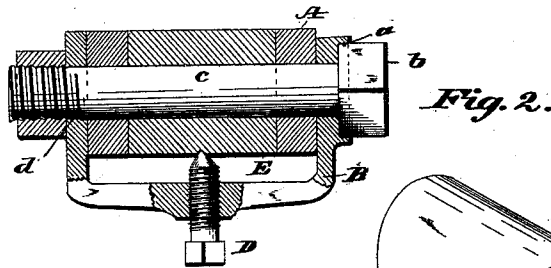

Fig. 2.

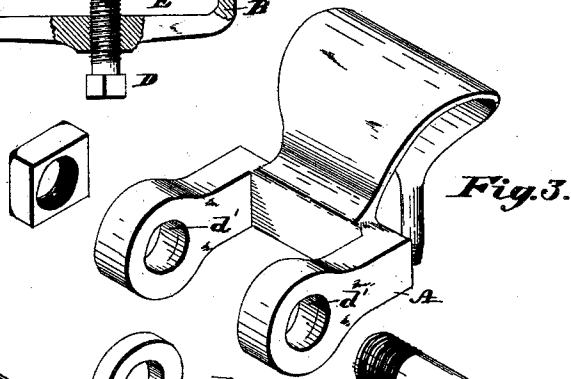

Fig. 3.

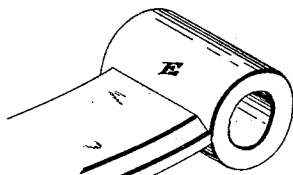

Fig. 6.

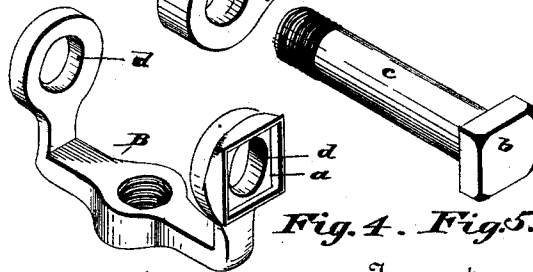

Fig. 4. Fig. 5.

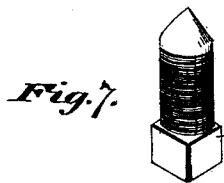

Fig. 7.

Witnesses
Edw. Lane
Edw. Smith

Inventor
Allen V. Smith
By *Bond & Muse*

Attorneys

UNITED STATES PATENT OFFICE.

ALLEN V. SMITH, OF CANTON, OHIO.

THILL-COUPLING.

SPECIFICATION forming part of Letters Patent No. 414,260, dated November 5, 1889.

Application filed February 7, 1889. Serial No. 298,976. (No model.)

To all whom it may concern:

Be it known that I, ALLEN V. SMITH, a citizen of the United States, residing at Canton, in the county of Stark and State of Ohio, have invented certain new and useful Improvements in Thill-Couplings; and I do hereby declare that the following is a full, clear, and exact description of the same, reference being had to the annexed drawings, making a part of this specification, in which—

Figure 1 is an isometrical view. Fig. 2 is a sectional view. Fig. 3 is a detached view of the shackle. Fig. 4 is a detached view of the yoke. Fig. 5 is a detached view of the connecting-bolt. Fig. 6 is a detached view of a portion of thill-iron, showing eye. Fig. 7 is a detached view of the set-screw.

The present invention has relation to thill-couplings; and its nature consists in the different parts and combination of parts hereinafter described, and particularly pointed out in the claims.

Similar letters of reference indicate corresponding parts in all the figures of the drawings.

In the accompanying drawings, A represents the shackle, which is constructed in the ordinary manner, and is provided with the ordinary clip for attaching the shackle to the axle of a vehicle. The yoke B is substantially of the form shown in the drawings, and is attached as illustrated in Figs. 1 and 2. This yoke is provided with the angular recess *a*, which is for the purpose of receiving the head *b* of the bolt *c*. It will be seen that the recess *a* is to correspond in form with the bolt-head *b*. This yoke B is provided with the apertures *d*, which are for the purpose of receiving the connecting-bolt *c*, as illustrated in Fig. 2. This yoke B is also provided with the set-screw D, which is for the purpose of pressing or bearing against the eye E. In the drawings the set-screw D is shown pointed,

but the same object can be accomplished by means of a blunt-ended set-screw. The object and purpose of the set-screw D are to press the thill-iron firmly against the connecting-bolt *c*, and thereby preventing any rattle, and at the same time preventing the bolt *c* from wearing in the eye E.

It will be seen that by providing the recess *a* and seating the head of the bolt therein, said bolt will move with the yoke as the thills proper are moved up and down at their free ends. The connecting-bolt *c* moves or turns in the apertures *d*' in the shackle A.

It will be seen that any desired number of set-screws may be used and arranged in the yoke B.

It will be seen that the yoke B, together with its set screw or screws, may be located on the top or upper side of the eye E, and the same object accomplished.

Having now fully described my invention, what I claim as new, and desire to secure by Letters Patent, is—

1. The combination of the shackle A, the yoke B, adapted to embrace the shackle, and provided with the angular recess *a*, adapted to receive the head of the bolt C, the thill-iron provided with the eye E, and the pointed set-screw D, substantially as and for the purpose set forth.

2. The combination of the shackle A, the yoke B, provided with the angular recess *a*, adapted to receive and hold the head of the bolt C, and the set-screw D, adapted to press against the eye E, substantially as and for the purpose set forth.

In testimony that I claim the above I have hereunto subscribed my name in the presence of two witnesses.

ALLEN V. SMITH.

Witnesses:

F. W. BOND,
L. C. WISE.