



(12) **EUROPEAN PATENT APPLICATION**

(43) Date of publication:
06.06.2018 Bulletin 2018/23

(51) Int Cl.:
D06F 58/20 (2006.01) D06F 58/24 (2006.01)

(21) Application number: **17203957.0**

(22) Date of filing: **28.11.2017**

(84) Designated Contracting States:
AL AT BE BG CH CY CZ DE DK EE ES FI FR GB GR HR HU IE IS IT LI LT LU LV MC MK MT NL NO PL PT RO RS SE SI SK SM TR
 Designated Extension States:
BA ME
 Designated Validation States:
MA MD

(72) Inventors:
 • **Chen, Lijun**
Nanjing city, Jiangsu 210000 (CN)
 • **Liu, Yun(PLC2)**
Nanjing, Jiangsu 210046 (CN)
 • **Lu, Fei**
Nanjing city, Jiangsu 210000 (CN)
 • **Qian, Shanliang**
Nanjing/ Jiangsu, Jiangsu 210046 (CN)
 • **Zhang, Xiuhua**
Nanjing, Jiangsu 210000 (CN)

(30) Priority: **30.11.2016 CN 201611085371**

(71) Applicant: **BSH Hausgeräte GmbH**
81739 München (DE)

(54) **LAUNDRY DRYING MACHINE**

(57) A laundry drying machine (1) includes a drying compartment (8) and a condensation compartment (6) that is in fluid communication with the drying compartment (8). A first heat exchange apparatus (63) is disposed in the condensation compartment (6). The drying compartment (8) is separated from the condensation compartment (6) by a common separation wall (5), and the separation wall (5) separately constitutes a part of a wall of the drying compartment (8) and a part of a wall of the condensation compartment (6). A second heat exchange apparatus (51) is disposed on the separation wall (5). The second heat exchange apparatus (51) may exchange heat with air in both the drying compartment (8) and the condensation compartment (6), to accelerate condensation of water in the air. Therefore, the condensation efficiency is improved compared with the prior art.

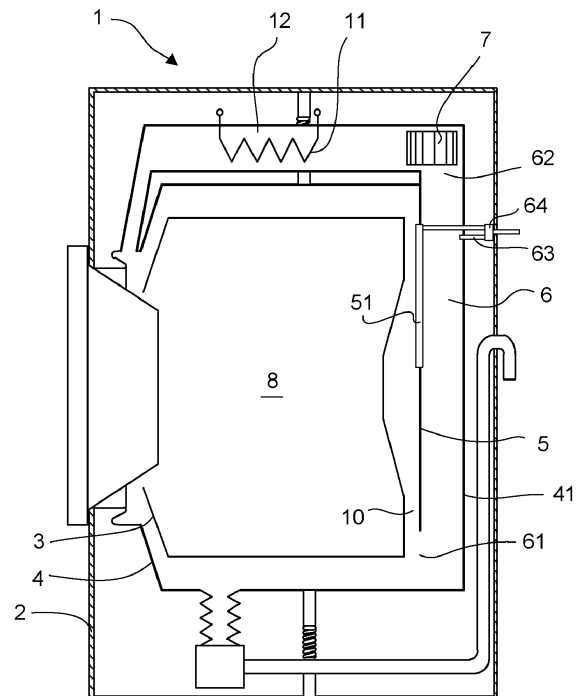

FIG. 1

Description

[0001] The present invention relates to a condensation apparatus of a laundry drying machine.

[0002] Chinese invention patent application CN 105 463 804 A discloses a laundry drying machine. The laundry drying machine has a drum driven by a motor to be rotatable and a tub sleeved on the drum. The tub is connected and in spatial communication with a condensation channel. The condensation channel is further connected to a fan and an air heating channel in sequence. The other end of the air heating channel is further in spatial communication with the tub. Therefore, an air circulation path is formed in the tub, the condensation channel, the fan, and the air heating channel. In a drying procedure, under the effect of the fan, high-temperature drying air formed in the air heating channel enters a laundry processing drum component, to heat wet laundry in the drum, to evaporate water in the laundry. The drying air with the evaporated water further enters the condensation channel, and in the condensation channel, the water in the drying air is condensed and becomes liquid again, and is separated from the drying air. Therefore, the drying air becomes low-temperature and dry again, enters the heating channel again when being driven by the fan, and starts a new round of circulation. The circulation repeats again and again and finally the laundry in the drum is dried. The condensation channel is connected to an inlet pipe of cooling water. In the drying procedure, the cooling water flows into the condensation channel from the inlet pipe, so as to exchange heat with the drying air that enters the condensation channel, and condense water in the drying air.

[0003] An objective of the present invention is to improve the condensation efficiency of a laundry drying machine.

[0004] To achieve the foregoing objective, the present invention provides a laundry drying machine, including a drying compartment and a condensation compartment that is in fluid communication with the drying compartment. A first heat exchange apparatus is disposed in the condensation compartment. The drying compartment is separated from the condensation compartment by a common separation wall, and the separation wall separately constitutes a part of a wall of the drying compartment and a part of a wall of the condensation compartment. A second heat exchange apparatus adapted to exchange heat with air in the drying compartment and the condensation compartment is disposed on the separation wall.

[0005] The first heat exchange apparatus may be a cooling water supply apparatus, an air cooling apparatus, or a heat pump evaporator. The second heat exchange apparatus makes use of the special structure that the separation wall is located between the condensation compartment and the drying compartment, and may exchange heat with air in both the drying compartment and the condensation compartment, so that the air exchanges heat with the first heat exchange apparatus in the con-

denation compartment to produce condensation, and the air in the condensation compartment and the drying compartment may also exchange heat with the second heat exchange apparatus, to further accelerate condensation of water in the air, and the condensed water generated therefrom flows down along the separation wall. Therefore, the condensation efficiency is improved compared with the prior art. The second heat exchange apparatus is disposed on the separation wall, has a simple structure, and occupies a relatively small space.

[0006] The separation wall is preferably made of a heat conductive material. Therefore, the separation wall can well transfer heat among the condensation compartment, the drying compartment, and the second heat exchange apparatus, and help to improve the condensation efficiency.

[0007] The separation wall may be made of a metal because the metal has preferable heat conductive performance. More preferably, the separation wall may be made of materials with relatively high heat conductive efficiency among metals such as aluminum and copper.

[0008] The separation wall may use a hollow two-layer structure, and the second heat exchange apparatus is disposed between the two-layer structure, so that the second heat exchange apparatus can be easily installed. An outer surface of the separation wall may be made into a flat shape, to prevent piling up of laundry fluffs in a drying process.

[0009] The second heat exchange apparatus includes a refrigerant channel, a cooling medium is allowed to pass through the refrigerant channel, and a wall of the refrigerant channel is made of a heat conduction material. The refrigerant may be water or air.

[0010] As one aspect of the present invention, the separation wall constitutes at least one part of the wall of the refrigerant channel. Therefore, the structure is simple, and assembly steps are reduced.

[0011] The wall of the refrigerant channel is exposed in at least one of the drying compartment or the condensation compartment.

[0012] The wall of the refrigerant channel may be further connected to the separation wall in a manner of being suitable for heat exchange.

[0013] In addition, the refrigerant channel may extend in a snakelike winding manner or spirally, and has an inlet and an outlet.

[0014] Preferably, the drying compartment and the condensation compartment are formed on a same tub.

[0015] In addition, the drying compartment has a rotatable drum that accommodates laundry, and a gap exists between the drum and the separation wall. After wet hot air exchanges heat with the second heat exchange apparatus, formed condensed water flows down along the separation wall. Because of the gap between the drum and the separation wall, the condensed water is prevented from wetting laundry in the drum.

[0016] The laundry drying machine includes a tub. A concave portion is disposed on a rear portion of the tub,

and the separation wall covers the concave portion from an inner portion of the tub, so as to form the condensation compartment between the concave portion and the separation wall. The drying compartment is formed on the other side of the separation wall, and the condensation compartment has an inlet formed between the separation wall and the tub and an outlet formed on the tub.

[0017] The following further describes preferred embodiments of the present invention with reference to the figures of the accompanying drawing.

FIG. 1 is a schematic structural diagram of a laundry drying machine;

FIG. 2 is a partial structural diagram of a tub viewing in a direction from an inner portion to a rear portion of a tub; and

FIG. 3 is a sectional view along direction A-A in FIG. 2.

[0018] As shown in FIG. 1, a laundry drying machine 1 has a rotatable drum 3 located in a case body 2 and a tub 4 sleeved on the drum 3. A concave portion 41 is disposed on a rear portion of the tub 4. A separation wall 5 covers the concave portion 41 from an inner portion of the tub 4, so as to form a condensation compartment 6 between the concave portion 41 and the separation wall 5. A drying compartment 8 is formed on the remaining part of the tub 4, that is, the other end of the separation wall 5. A gap 10 exists between the drum 3 and the separation wall 5. The condensation compartment 6 has an inlet 61 formed between the separation wall 5 and the tub 4 and an outlet 62 formed on the tub 4. The outlet 62 of the condensation compartment 6 is connected to a fan 7 and a hot air pipe 12 in which an air heater 11 is disposed. The downstream of the hot air pipe 12 is further connected to the drying compartment 8 of the tub 4. Therefore, an air circulation path is formed in the drying compartment 8, the condensation compartment 6, the fan 7, and the hot air pipe 12. Under the effect of the fan 7, air is heated by the air heater 11 and then enters the drying compartment 8, further enters the drum 3 that is in spatial communication with the drying compartment 8, exchanges heat with wet laundry, and takes away water in the laundry. Wet hot air that carries water enters the condensation compartment 6, and in the condensation compartment 6, the water in the air is condensed and separated from the air. Then, relatively dry air enters the hot air channel 12 again and is heated by the air heater 11 to enter the next circulation.

[0019] A first heat exchange apparatus is disposed in the condensation compartment 6, and is specifically implemented as a cooling water supply pipe 63. The cooling water supply pipe 63 is connected to a water valve apparatus 64 and controlled by the water valve apparatus 64.

[0020] The separation wall 5 is preferably made of met-

als with preferable heat conduction performance such as aluminum and copper. A second heat exchange apparatus is disposed on the separation wall 5, and is specifically implemented as a refrigerant channel 51. The refrigerant channel 51 is in fluid communication with the water valve apparatus 64, so as to lead in cooling water. An outlet 54 of the refrigerant channel 51 is located on the separation wall 5. Therefore, the cooling water flows down to the bottom of the tub 4 along the separation wall 5, and is further discharged.

[0021] As shown in FIG. 3, in an implementation, the separation wall 5 uses a hollow two-layer structure, and includes a first layer 52 and a second layer 53, and the refrigerant channel 51 is disposed between the first layer and the second layer. A wall 510 of the refrigerant channel 51 is in heat conduction connection to the first layer 52 and the second layer 53 of the separation wall 5. The wall 510 of the refrigerant channel 51 is made of a heat conduction material. Therefore, the cooling water in the refrigerant channel 51 further exchanges heat with air in the drying compartment 8 and the condensation compartment 6 under the heat transfer effect between the wall 510 of the refrigerant channel 51 and the first layer 52 and the second layer 53 of the separation wall 5.

[0022] In another implementation, the separation wall 5 is a single-layer structure, and the refrigerant channel 51 is welded on one side or two sides of the separation wall 5.

[0023] In still another implementation, the separation wall 5 constitutes at least one part of the wall 510 of the refrigerant channel 51. For example, the refrigerant channel 51 is formed on the separation wall 5.

[0024] As can be seen, the wall 510 of the refrigerant channel 51 is exposed in at least one of the drying compartment 8 or the condensation compartment 6, or the wall 510 of the condensation channel 51 is in heat conduction connection to the separation wall 5.

[0025] As shown in FIG. 2, the refrigerant channel 51 extends in a snakelike winding manner. In this way, a refrigerant channel 51 as long as possible may be arranged in a limited space. Therefore, the refrigerant channel 51 has a preferable heat exchange effect.

45 Claims

1. A laundry drying machine (1), comprising a drying compartment (8) and a condensation compartment (6) that is in fluid communication with the drying compartment (8), wherein a first heat exchange apparatus (63) is disposed in the condensation compartment (6), the drying compartment (8) is separated from the condensation compartment (6) by a common separation wall (5), and the separation wall (5) separately constitutes a part of a wall of the drying compartment (8) and a part of a wall of the condensation compartment (6), **characterized in that** a second heat exchange apparatus (51) adapted to

- exchange heat with air in the drying compartment (8) and the condensation compartment is (6) disposed on the separation wall (5).
2. The laundry drying machine (1) according to claim 1, **characterized in that** the separation wall (5) is made of a heat conductive material. 5
 3. The laundry drying machine (1) according to claim 2, **characterized in that** the separation wall (5) is made of a metal. 10
 4. The laundry drying machine (1) according to any preceding claim, **characterized in that** the separation wall (5) comprises a hollow two-layer structure (52, 53), and the second heat exchange apparatus (51) is disposed between the two-layer structure (52, 53). 15
 5. The laundry drying machine (1) according to any preceding claim, **characterized in that** the second heat exchange apparatus (51) comprises a refrigerant channel (51), a cooling medium being allowed to pass through the refrigerant channel (51), and a wall (510) of the refrigerant channel (51) is made of a heat conductive material. 20
25
 6. The laundry drying machine (1) according to claim 5, **characterized in that** the separation wall (5) constitutes at least one part of the wall (510) of the refrigerant channel (51). 30
 7. The laundry drying machine (1) according to one of claims 5 and 6, **characterized in that** the wall (510) of the refrigerant channel (51) is exposed in at least one of the drying compartment (8) and the condensation compartment (6). 35
 8. The laundry drying machine (1) according to one of claims 5 to 7, **characterized in that** the wall (510) of the refrigerant channel (51) is connected to the separation wall (5) in a manner of being suitable for heat exchange. 40
 9. The laundry drying machine (1) according to one of claims 5 to 8, **characterized in that** the refrigerant channel (51) extends in a snakelike winding manner or spirally, and has an inlet and an outlet. 45
 10. The laundry drying machine (1) according to any preceding claim, **characterized in that** the drying compartment (8) and the condensation compartment (6) are formed on a same tub (4). 50
 11. The laundry drying machine (1) according to any preceding claim, **characterized in that** the drying compartment (8) has a rotatable drum (3) that accommodates laundry, and a gap exists between the drum (3) and the separation wall (5). 55
 12. The laundry drying machine (1) according to any preceding claim, **characterized in that** a tub (4) is comprised, a concave portion (41) is disposed on a rear portion of the tub (4), and the separation wall (5) covers the concave portion (41) from an inner portion of the tub (4), so as to form the condensation compartment (6) between the concave portion (41) and the separation wall (5), the drying compartment (8) is formed on the other side of the separation wall (5), and the condensation compartment (6) has an inlet (61) formed between the separation wall (5) and the tub (4) and an outlet (62) formed on the tub (4).

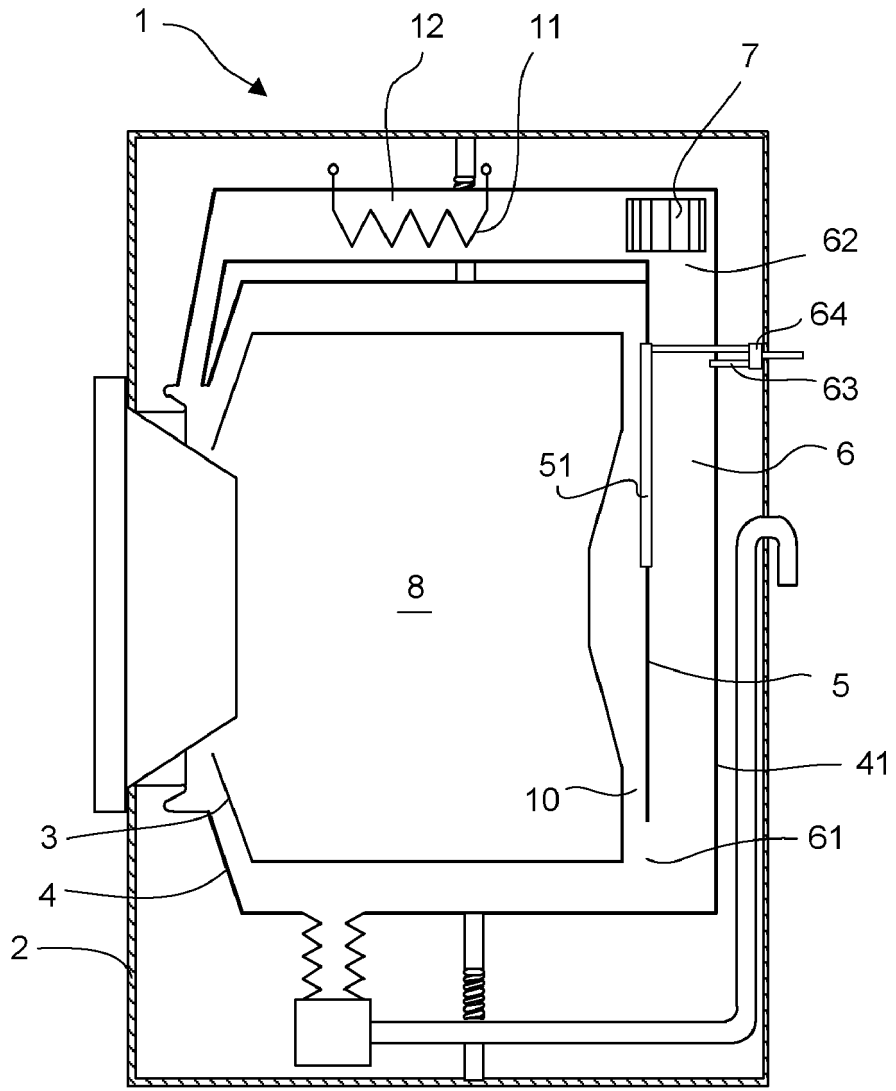

FIG. 1

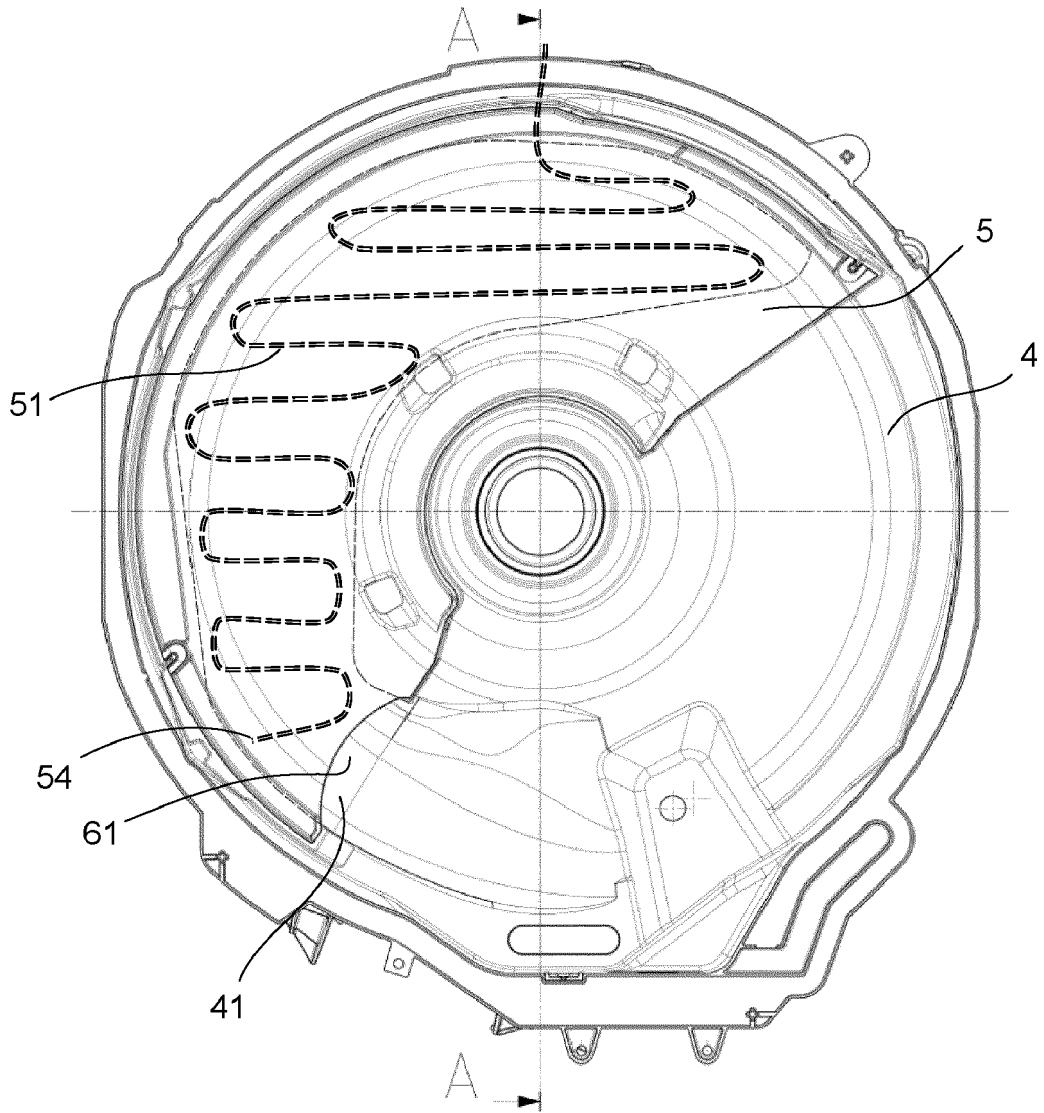

FIG. 2



EUROPEAN SEARCH REPORT

Application Number
EP 17 20 3957

5

DOCUMENTS CONSIDERED TO BE RELEVANT			
Category	Citation of document with indication, where appropriate, of relevant passages	Relevant to claim	CLASSIFICATION OF THE APPLICATION (IPC)
X	KR 2013 0075756 A (LG ELECTRONICS INC [KR]) 5 July 2013 (2013-07-05)	1-3,5-8, 10,11	INV. D06F58/20 D06F58/24
Y	* paragraphs [0094], [0132] - [0136]; figures 1,9-14 *	4,9	
X	US 2008/006308 A1 (CLASSEN EGBERT [DE] ET AL) 10 January 2008 (2008-01-10)	1-3,10, 11	
	* paragraphs [0010], [0011], [0029] - [0034]; figure 1 *		
X	KR 2008 0071425 A (LG ELECTRONICS INC [KR]) 4 August 2008 (2008-08-04)	1-3,10, 11	
	* paragraphs [0054] - [0059]; figure 6 *		
Y	EP 2 019 160 A1 (CANDY SPA [IT]) 28 January 2009 (2009-01-28)	4	
	* paragraph [0044]; figures 3,4 *		
Y	KR 2011 0125390 A (LG ELECTRONICS INC [KR]) 21 November 2011 (2011-11-21)	9	TECHNICAL FIELDS SEARCHED (IPC)
A	WO 93/17169 A1 (MERLONI ANTONIO SPA [IT]) 2 September 1993 (1993-09-02)	1	
	* page 5, line 13 - line 18; figure 4 *		D06F
A	KR 2008 0081755 A (SAMSUNG ELECTRONICS CO LTD [KR]) 10 September 2008 (2008-09-10)	1	
	* figure 1 *		
The present search report has been drawn up for all claims			
Place of search Munich		Date of completion of the search 9 February 2018	Examiner Kising, Axel
CATEGORY OF CITED DOCUMENTS		T : theory or principle underlying the invention E : earlier patent document, but published on, or after the filing date D : document cited in the application L : document cited for other reasons & : member of the same patent family, corresponding document	
X : particularly relevant if taken alone Y : particularly relevant if combined with another document of the same category A : technological background O : non-written disclosure P : intermediate document			

EPO FORM 1503 03.82 (P04C01)

10

15

20

25

30

35

40

45

50

55

ANNEX TO THE EUROPEAN SEARCH REPORT
ON EUROPEAN PATENT APPLICATION NO.

EP 17 20 3957

5 This annex lists the patent family members relating to the patent documents cited in the above-mentioned European search report.
The members are as contained in the European Patent Office EDP file on
The European Patent Office is in no way liable for these particulars which are merely given for the purpose of information.

09-02-2018

Patent document cited in search report	Publication date	Patent family member(s)	Publication date
KR 20130075756 A	05-07-2013	CN 102428226 A	25-04-2012
		CN 103911833 A	09-07-2014
		CN 103911834 A	09-07-2014
		CN 103911835 A	09-07-2014
		CN 103938409 A	23-07-2014
		EP 2435626 A2	04-04-2012
		EP 2711449 A2	26-03-2014
		EP 2711450 A2	26-03-2014
		EP 2711451 A2	26-03-2014
		EP 2719810 A1	16-04-2014
		EP 3176313 A1	07-06-2017
		ES 2569740 T3	12-05-2016
		ES 2609397 T3	20-04-2017
		ES 2632598 T3	14-09-2017
		KR 20100129116 A	08-12-2010
		KR 20100129117 A	08-12-2010
		KR 20100129140 A	08-12-2010
		KR 20100129151 A	08-12-2010
		KR 20100129242 A	08-12-2010
		KR 20130071461 A	28-06-2013
KR 20130072235 A	01-07-2013		
KR 20130074791 A	04-07-2013		
KR 20130075756 A	05-07-2013		
PL 2711449 T3	31-10-2016		
US 2012090189 A1	19-04-2012		
US 2014150276 A1	05-06-2014		
US 2014150277 A1	05-06-2014		
US 2014150278 A1	05-06-2014		
US 2014150279 A1	05-06-2014		
WO 2010137910 A2	02-12-2010		
US 2008006308 A1	10-01-2008	CN 2917542 Y	04-07-2007
		DE 102004044176 A1	30-03-2006
		EP 1791459 A1	06-06-2007
		US 2008006308 A1	10-01-2008
		WO 2006029953 A1	23-03-2006
KR 20080071425 A	04-08-2008	NONE	
EP 2019160 A1	28-01-2009	NONE	
KR 20110125390 A	21-11-2011	NONE	
WO 9317169 A1	02-09-1993	EP 0628099 A1	14-12-1994
		IT 1254215 B	14-09-1995
		JP H07503871 A	27-04-1995

EPO FORM P0459

For more details about this annex : see Official Journal of the European Patent Office, No. 12/82

55

**ANNEX TO THE EUROPEAN SEARCH REPORT
ON EUROPEAN PATENT APPLICATION NO.**

EP 17 20 3957

5 This annex lists the patent family members relating to the patent documents cited in the above-mentioned European search report.
The members are as contained in the European Patent Office EDP file on
The European Patent Office is in no way liable for these particulars which are merely given for the purpose of information.

09-02-2018

10

Patent document cited in search report	Publication date	Patent family member(s)	Publication date
		KR 100272135 B1	15-11-2000
		WO 9317169 A1	02-09-1993

KR 20080081755 A	10-09-2008	EP 1967633 A2	10-09-2008
		KR 20080081755 A	10-09-2008
		US 2008216517 A1	11-09-2008

15

20

25

30

35

40

45

50

EPO FORM P0459

55

For more details about this annex : see Official Journal of the European Patent Office, No. 12/82

REFERENCES CITED IN THE DESCRIPTION

This list of references cited by the applicant is for the reader's convenience only. It does not form part of the European patent document. Even though great care has been taken in compiling the references, errors or omissions cannot be excluded and the EPO disclaims all liability in this regard.

Patent documents cited in the description

- CN 105463804 A [0002]