

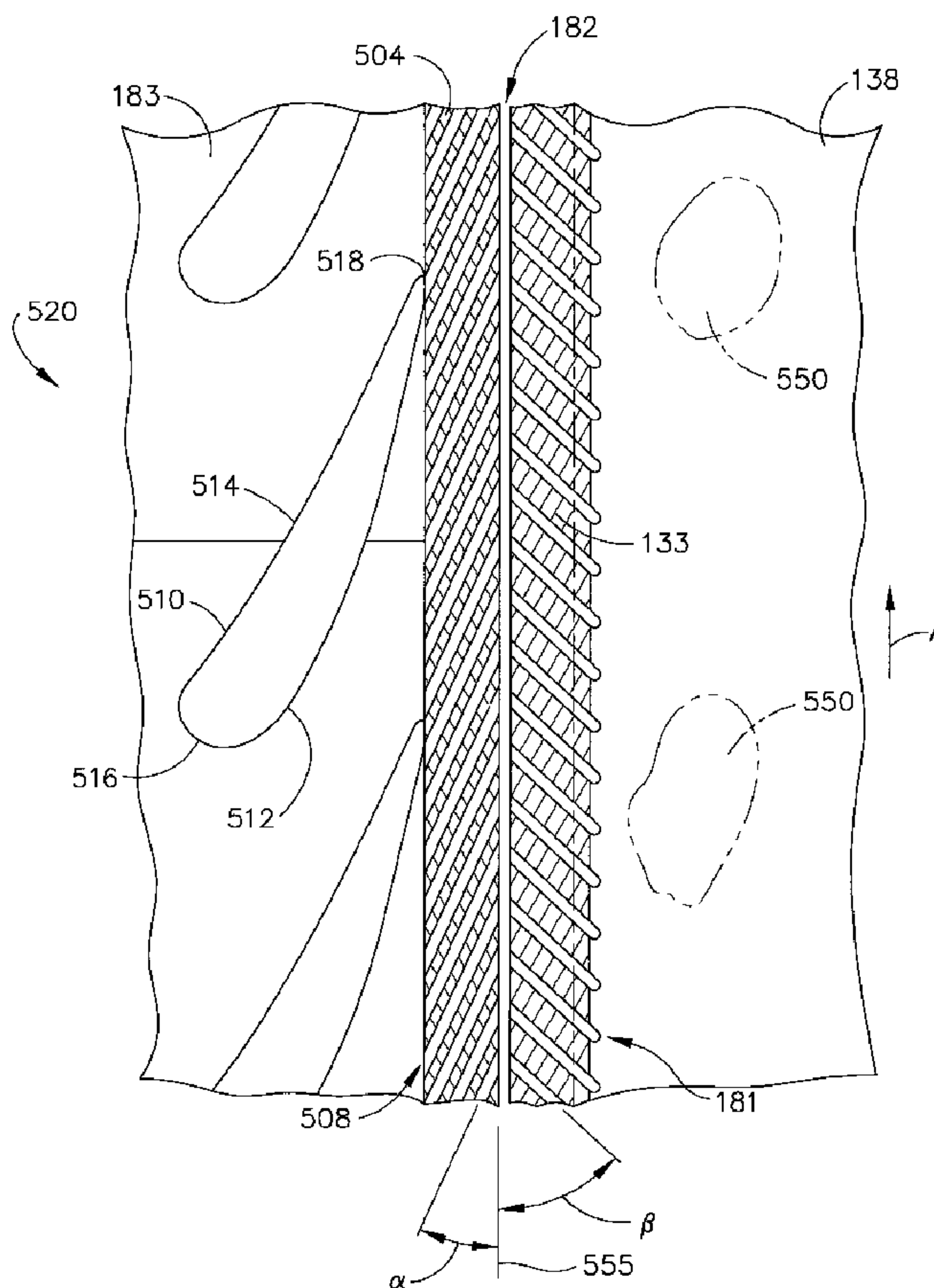

(22) **Date de dépôt/Filing Date:** 2007/09/20
 (41) **Mise à la disp. pub./Open to Public Insp.:** 2008/05/30
 (45) **Date de délivrance/Issue Date:** 2015/01/06
 (30) **Priorité/Priority:** 2006/11/30 (US11/565,229)

(51) **Cl.Int./Int.Cl.** *F01D 9/02* (2006.01),
F01D 25/14 (2006.01), *F02C 7/18* (2006.01),
F02K 1/38 (2006.01)
 (72) **Inventeurs/Inventors:**
 LEE, CHING-PANG, US;
 ESTILL, ERIC ALAN, US;
 LAFLEN, JAMES HARVEY, US;
 VITT, PAUL HADLEY, US;
 WYMORE, MICHAEL ELLIOT, US
 (73) **Propriétaire/Owner:**
 GENERAL ELECTRIC COMPANY, US
 (74) **Agent:** CRAIG WILSON AND COMPANY

(54) **Titre : METHODE ET SYSTEME FACILITANT LE REFROIDISSEMENT DES MOTEURS A TURBINE**
 (54) **Title: METHOD AND SYSTEM TO FACILITATE COOLING TURBINE ENGINES**



(57) **Abrégé/Abstract:**

An engine assembly including a nozzle assembly. The nozzle assembly includes an inner band, an outer band (183) including an aft flange (504) and a radial inner surface (522), the aft flange including a plurality of cooling holes (508) configured to direct cooling fluid (526) therefrom at an oblique discharge angle (α), and at least one airfoil vane (510) extending between the inner band and the outer band.

METHOD AND SYSTEM TO FACILITATE COOLING TURBINE ENGINES

ABSTRACT OF THE DISCLOSURE

An engine assembly including a nozzle assembly. The nozzle assembly includes an inner band, an outer band (183) including an aft flange (504) and a radial inner surface (522), the aft flange including a plurality of cooling holes (508) configured to direct cooling fluid (526) therefrom at an oblique discharge angle (α), and at least one airfoil vane (510) extending between the inner band and the outer band.

214422

METHOD AND SYSTEM TO FACILITATE COOLING TURBINE ENGINES

BACKGROUND OF THE INVENTION

This invention relates generally to gas turbine engines and, more particularly, to methods and systems for cooling integral turbine nozzle and shroud assemblies.

One known approach to increase the efficiency of gas turbine engines requires raising the turbine operating temperature. However, as operating temperatures are increased, the thermal limits of certain engine components may be exceeded, resulting in reduced service life and/or material failure. Moreover, the increased thermal expansion and contraction of components may adversely affect component clearances and/or component interfitting relationships. Consequently, conventional cooling systems have been incorporated into gas turbine engines to facilitate cooling such components to avoid potentially damaging consequences when exposed to elevated operating temperatures.

It is known to extract, from the main airstream, air from the compressor for cooling purposes. To facilitate maintaining engine operating efficiency, the volume of cooling air extracted is typically limited to a small percentage of the total main airstream. As such, this requires that the cooling air be utilized with the utmost efficiency in order to facilitate maintaining the temperatures of components within safe limits.

For example, one component that is subjected to high temperatures is the shroud assembly located immediately downstream of the high pressure turbine nozzle extending from the combustor. The shroud assembly extends circumferentially about the rotor of the high pressure turbine and thus defines a portion of the outer boundary (flow path) of the main gas stream flowing through the high pressure turbine. Gas turbine engine efficiency may be negatively affected by a fluctuation in turbine blade tip clearance measured between a radially outer surface of the turbine blade and a

214422

radially inner surface of the shroud assembly. During transient engine operation, turbine blade tip clearance is a function of a difference in radial displacement of the turbine rotor blade and the shroud assembly. The turbine rotor typically has a larger mass than the stationary shroud system and, thus, during turbine operation, the turbine rotor typically has a slower thermal response than the shroud assembly. When the difference in the rotor blade radial displacement and the shroud assembly radial displacement is too great, the blade tip clearance is increased, which may result in reducing engine efficiency.

Moreover, during engine operation, a gap may be defined between a trailing edge of the high pressure turbine nozzle outer band and a leading edge of the adjacent shroud segment. Cooling air, including, without limitation, nozzle leakage and/or purge flow, enters the gap and flows into the main gas stream channeled through the high pressure turbine. Cooling air is generally provided by a row of axially aligned cooling holes positioned in an outer band trailing edge that are directed towards the shroud leading edge forward face to facilitate cooling the end faces and purging the gap. Because known nozzle outer band trailing edges and shroud leading edges have a simple 90° corner, the gap opens directly into the main gas stream. During engine operation, as the main gas stream flows through the nozzle vanes, a circumferential gas pressure variation may be created downstream from the vane trailing edge. This circumferential gas pressure variation may cause localized hot gas ingestion into the gap between the outer band and the shroud segment. As a result, cooling air flowing through the gap may not effectively cool the downstream shroud segment.

BRIEF DESCRIPTION OF THE INVENTION

In one aspect, a method of assembling a gas turbine engine is provided. The method includes coupling at least one turbine nozzle segment within the gas turbine engine. The at least one turbine nozzle segment includes at least one airfoil vane extending between an inner band and an outer band that includes an aft flange and a radial inner surface. The method also includes coupling at least one turbine shroud segment downstream from the at least one turbine nozzle segment, wherein the at least one turbine shroud segment includes a leading edge and a radial inner surface, and

214422

coupling a cooling fluid source in flow communication with the at least one turbine nozzle segment such that cooling fluid channeled to each turbine nozzle outer band aft flange is directed at an oblique discharge angle towards the leading edge of the at least one turbine shroud segment.

In another aspect, an engine assembly is provided. The engine assembly includes a nozzle assembly including an inner band, an outer band including an aft flange and a radial inner surface. The aft flange includes a plurality of cooling holes configured to direct cooling fluid therefrom at an oblique discharge angle. The engine assembly also includes at least one airfoil vane extending between the inner band and the outer band.

In yet another aspect, a gas turbine engine is disclosed. The engine includes a nozzle assembly including an inner band, an outer band, and at least one airfoil vane extending between the inner band and the outer band. The outer band includes an aft flange and a radial inner surface, and the aft flange includes a plurality of cooling holes configured to direct cooling fluid therefrom at an oblique discharge angle.

BRIEF DESCRIPTION OF THE DRAWINGS

Figure 1 is a side view of an exemplary shroud assembly schematically illustrating high pressure cooling air flow through the shroud assembly;

Figure 2 is a side view of an alternative shroud assembly schematically illustrating high pressure cooling air flow through the shroud assembly;

Figure 3 is an enlarged schematic cross-sectional view of a gap defined between a turbine nozzle and the shroud assembly shown in Figure 1 or 2; and

Figure 4 is a plan view of the turbine nozzle and shroud assembly shown in Figure 3.

DETAILED DESCRIPTION OF THE INVENTION

The present invention provides a turbine shroud cooling system for minimizing hot gas ingestion into a gap defined between a trailing edge of the high pressure turbine

214422

nozzle and a leading edge of the adjacent shroud segment. The turbine shroud cooling system facilitates forming a barrier between the hot gas flow path flowing through the high pressure turbine and cooling air flowing through a gap defined between the turbine nozzle and the shroud segment.

Although the present invention is described below in reference to its application in connection with cooling a shroud assembly of an aircraft gas turbine, it should be apparent to those skilled in the art and guided by the teachings herein provided that with appropriate modification, the cooling system or assembly of the present invention can also be suitable to facilitate cooling other turbine engine components, such as, but not limited to, the nozzle and/or vane sections.

Figure 1 is a side view of an exemplary shroud assembly schematically illustrating high pressure cooling air flow through the shroud assembly. Figure 2 is a side view of an alternative shroud assembly schematically illustrating high pressure cooling air flow through the shroud assembly. To facilitate controlling shroud assembly thermal response and/or shroud assembly displacement during transient engine operation, in the exemplary embodiment, a turbine engine cooling assembly 108 includes a shroud assembly, generally indicated as 110, for a high pressure turbine section 112 and a low pressure turbine section 114 of a gas turbine engine. It should be apparent to those skilled in the art and guided by the teachings herein provided that turbine engine cooling assembly 108 may be suitable to facilitate cooling other sections of the gas turbine engine, such as, but not limited to, a nozzle section and/or a vane section.

Shroud assembly 110 includes turbine engine cooling components in the form of shroud segments 130. Each shroud segment 130 includes a forward mounting hook 132 at a circumferential leading edge 133 of shroud segment 130. Shroud segment 130 also includes a midsection mounting hook 134 and an aft mounting hook 136 adjacent to a circumferential trailing edge 137 of shroud segment 130.

A plurality of shroud segments 130 are arranged circumferentially in a generally known fashion to form an annular segmented shroud. Shroud segments 130 define an annular clearance between high pressure turbine blades (not shown) and a radially

214422

inner surface 138 of a high pressure turbine section of shroud segments 130, and between low pressure turbine blades (not shown) and a radially inner surface 140 of a low pressure turbine section of shroud segment 130. A plurality of segmented shroud supports 144 interconnect shroud segments 130. Each shroud support 144 circumferentially spans and supports adjacent shroud segments 130. In alternative embodiments, shroud supports 144 are modified to support any suitable number of shroud segments 130 less than or greater than two shroud segments 130. In the exemplary embodiment, shroud assembly 110 includes twenty-six (26) shroud segments 130 and thirteen (13) shroud supports 144, although any suitable number of shroud segments 130 and/or shroud supports 144 may be utilized in alternative embodiments.

Each shroud support 144 includes a forward section 146, a midsection 148 and an aft section 150 that form respective forwardly projecting hangers 152, 154 and 156. Mounting hooks 132, 134 and 136 are received by cooperating hangers 152, 154 and 156, respectively, in tongue-in-groove, or hook-in-hanger, interconnections such that shroud support 144 supports respective shroud segments 130.

Shroud assembly 110 includes an annular shroud ring structure 158 that supports shroud supports 144. In one embodiment, shroud ring structure 158 is a one-piece, continuous annular shroud ring structure. A radial position of each shroud support 144, as well as of each shroud segment 130, is closely controlled by only two annular position control rings 162 and 164 formed on shroud ring structure 158. In contrast to conventional shroud ring structures, to facilitate reducing or limiting a weight of shroud assembly 110, shroud ring structure 158 includes only two position control rings 162 and 164. A midsection position control ring 162 includes an axially forwardly projecting hanger 166 that receives and/or cooperates with a rearwardly projecting mounting hook 167 formed by support structure midsection 148 in a first circumferential tongue-in-groove or hook-in-hanger interconnection. An aft position control ring 164 includes an axially forwardly projecting hanger 168 that receives and/or cooperates with a rearwardly projecting mounting hook 169 of support structure aft section 150 in second circumferential tongue-in-groove or hook-in-hanger interconnection.

214422

In the exemplary embodiment, hangers 166 and/or 168 are in direct axial alignment, i.e., aligned generally in the same radial plane, with respective hanger 154 and hanger 156 to facilitate maximizing the radial support and/or radial position control provided to shroud support 144 and, thus, corresponding shroud segments 130. This alignment orientation facilitates increasing the rigidity of the entire shroud support assembly. In an alternative embodiment, shown in Figure 2, hanger 166 and/or hanger 168 are in an offset axial alignment, i.e., not aligned generally in the same radial plane, with respective hanger 154 and hanger 156. In the exemplary embodiment, shroud ring structure 158 is bolted to the combustor case (not shown) at an aft end of shroud ring structure 158. Shroud ring structure 158 is cantilevered away from leading edge 133 at the combustor case interface. As such, midsection position control ring 162 is positioned several inches away from the combustor aft flange (not shown), and is thereby divorced from any non-uniform circumferential variations in radial deflection in the combustor case.

In the exemplary embodiment, high pressure cooling air 170 is extracted from a compressor (not shown) positioned upstream of shroud assembly 110. A first portion 171 of high pressure cooling air 170 extracted from the compressor facilitates cooling high pressure turbine section 112. A second portion 172 of high pressure cooling air 170 extracted from the compressor facilitates cooling low pressure turbine section 114. Referring further to Figure 1, directional arrows corresponding to first portion 171 and second portion 172 illustrate at least a portion of a flow path of first portion 171 of high pressure cooling air 170 through a high pressure turbine section active convection cooling zone 173 and second portion 172 of high pressure cooling air 170 through a low pressure turbine section active convection cooling zone 186 (described below), respectively.

In this embodiment, first portion 171 of high pressure cooling air 170 is metered into a first or high pressure turbine section active convection cooling zone 173. More specifically, first portion 171 of high pressure cooling air 170 is metered through at least one high pressure turbine section (HPTS) feed hole 174 defined in shroud support 144. First portion 171 of high pressure cooling air 170 impinges against a

214422

pan-shaped HPTS impingement baffle 175 positioned within high pressure turbine section active convection cooling zone 173. Baffle 175 is coupled to shroud support 144 and thus at least partially defines an upper HPTS cavity or plenum 176. First portion 171 of high pressure cooling air 170 is then metered through a plurality of perforations 177 formed in impingement baffle 175 as cooling air into a lower HPTS cavity or plenum 178 defined in shroud segment 130, wherein the cooling air impinges against a backside 179 of shroud segment 130. A portion, such as spent impingement cooling air 180, of high pressure cooling air exits plenum 178 through a plurality of forwardly directed cooling openings 181 defined at, or near, shroud segment leading edge 133 configured to facilitate purging a gap 182 defined between high pressure turbine nozzle outer band 183 and shroud segment leading edge 133. A portion 184 of high pressure cooling air is metered through a plurality of rearwardly directed cooling openings 185 defined in shroud segment 130 to facilitate film cooling inner surface 138 and/or 140. Spent impingement cooling air 180 of high pressure cooling air exiting cooling openings 181 facilitates preventing or limiting hot gas injection or recirculation into shroud assembly 110 at leading edge 133.

Second portion 172 of high pressure cooling air 170 extracted from the compressor facilitates cooling low pressure turbine section 114. In this embodiment, second portion 172 of high pressure cooling air 170 is metered into a second or low pressure turbine section active convection cooling zone 186. More specifically, second portion 172 of high pressure cooling air 170 is metered through at least one low pressure turbine feed hole 187 defined in shroud support 144. Second portion 172 of high pressure cooling air 170 impinges against a pan-shaped Low Pressure Turbine Section impingement baffle 188 positioned within low pressure turbine section active convection cooling zone 186. Baffle 188 is coupled to shroud support 144, and thus at least partially defines an upper LPTS cavity or plenum 189. Second portion 172 of high pressure cooling air 170 is then metered through perforations 190 defined in impingement baffle 188 and into a lower LPTS cavity or plenum 191 wherein high pressure cooling air impinges against a backside 192 of shroud segment 130. Cooling air 193 exits plenum 191 through a plurality of rearwardly directed cooling openings

214422

194 defined through shroud segment 130, to facilitate film cooling radially inner surface 140 of trailing edge 137 of shroud segment 130 downstream.

As shown in Figure 1, high pressure cooling air 170 is initially directed into a duct 204 defined at least partially between high pressure turbine nozzle outer band 183 and the portion of shroud ring structure 158 forming midsection position control ring 162. High pressure cooling air 170 is separated within duct 204 into first portion 171, and into second portion 172, as high pressure cooling air 170 is directed through duct 204. First portion 171 of high pressure cooling air 170 is metered through HPTS feed holes 174 into active convection cooling zone 173 and into plenum 178 to facilitate impingement cooling in high pressure turbine section 112. Spent impingement cooling air 180 exits shroud segment 130 through shroud segment leading edge cooling openings 181 to facilitate purging gap 182 defined between high pressure turbine nozzle outer band 183 and shroud segment 130, and/or through cooling openings 185 defined at a trailing end 205 of high pressure turbine section 112 to facilitate film cooling inner surface 138 and/or 140 of shroud segment 130.

Second portion 172 of high pressure cooling air 170 is directed into second active convection cooling zone 186 that is defined at least partially between shroud support 144 and shroud segment 130, and between midsection position control ring 162 and aft position control ring 164. Second portion 172 of high pressure cooling air 170 facilitates cooling low pressure turbine section 114. In one embodiment, second portion 172 of high pressure cooling air 170 is metered through a plurality of low pressure turbine feed holes 187 defined in shroud support 144. More specifically, second portion 172 of high pressure cooling air 170 is metered directly into active convection cooling zone 186 to facilitate shroud segment impingement cooling in low pressure turbine section 114, such that cooling air bypasses a third region 210 defining an inactive convection cooling zone 211 between shroud support 144 and shroud ring structure 158, and between midsection position control ring 162 and aft position control ring 164. Spent impingement cooling air exits shroud segment 130 through cooling openings 194 defined at or near trailing edge 137 of shroud segment 130.

214422

In the flow path illustrated in Figure 1, high pressure turbine section active convection cooling zone 173 and/or low pressure turbine section active convection cooling zone 186 are directly and actively cooled. Low pressure turbine section inactive convection cooling zone 211 is inactive, i.e., no high pressure cooling air flows through inactive convection cooling zone 211. Thus, a thermal response within inactive convection cooling zone 211 to environmental conditions created during transient engine operation is reduced and/or retarded. As a result, transient displacement of midsection position control ring 162 and/or aft position control ring 164 is also reduced and/or retarded.

As shown in Figure 2, high pressure cooling air 170 is directed into duct 204 defined at least partially between high pressure turbine nozzle outer band 183 and shroud ring structure 158 forming midsection position control ring 162. High pressure cooling air 170 is separated into first portion 171 and second portion 172. First portion 171 of high pressure cooling air 170 is metered through HPTS feed hole(s) 174 into high pressure turbine section active convection cooling zone 173 at least partially defining plenum 176 and plenum 178 to facilitate shroud segment impingement cooling in high pressure turbine section 112. Spent impingement cooling air 180 exits shroud segment 130 through shroud segment leading edge cooling openings 181 to facilitate purging gap 182 between high pressure turbine nozzle outer band 183 and shroud segment 130 and/or through cooling openings 185 defined at trailing end 205 of high pressure turbine section 112 to facilitate film cooling inner surface 138 and/or 140.

Second portion 172 of high pressure cooling air 170 is directed into low pressure turbine section active convection cooling zone 186 defined at least partially between shroud support 144 and shroud segment 130, and between midsection position control ring 162 and aft position control ring 164 to facilitate cooling low pressure turbine section 114. In one embodiment, second portion 172 of high pressure cooling air 170 is metered through a plurality of low pressure turbine feed holes 187 defined through shroud support 144. Second portion 172 of high pressure cooling air 170 is metered directly into low pressure turbine section active convection cooling zone 186 at least partially defining plenum 189 and plenum 191 to facilitate shroud segment

214422

impingement cooling in low pressure turbine section 114. Spent impingement cooling air 193 exits shroud segment 130 through cooling openings 194 defined at or near trailing edge 137 of shroud segment 130.

The shroud cooling assembly as shown in Figures 1 and 2 directs high pressure cooling air directly into high pressure turbine section active convection cooling zone 173 and/or low pressure turbine section active convection cooling zone 186 through respective feed hole(s) 174 and feed hole(s) 187.

In the shroud cooling assembly as shown in Figures 1 and 2, high pressure cooling air is not metered or directed through low pressure turbine section inactive convection cooling zone 211. As a result, the components defining low pressure turbine section inactive convection cooling zone 211 respond relatively slower to thermal conditions and/or environments during transient engine operation than the components defining an active convection cooling zone within conventional shroud cooling assemblies. This slower response to thermal conditions and/or environments facilitates relatively slower transient displacement of midsection position control ring 162 and/or aft position control ring 164.

Thus, by bypassing the low pressure turbine section shroud ring structure, the high pressure cooling air flow paths shown in Figures 1 and 2 facilitate reducing and/or retarding the transient thermal response and/or displacement of the shroud segment during transient engine operation. The slower response further facilitates improved blade tip clearance and turbine engine efficiency.

Figure 3 is an enlarged schematic cross-sectional view of turbine nozzle band 183, gap 182 and shroud segment leading edge 133. Turbine nozzle outer band 183 is included as part of a turbine nozzle segment 520. Turbine nozzle segments 520 generally include a plurality of circumferentially-spaced airfoil vanes 510, shown in Figure 4. The vanes extend between radial outer band 183 and a radial inner band (not shown). In the exemplary embodiment, outer band 183 includes a radial inner surface 522 and an aft flange 504. Aft flange 504 includes an upstream face 506, trailing edge 500, and a plurality of cooling openings 508 that extend from face 506 to

214422

trailing edge 500. Cooling openings 508 are oriented to facilitate channeling cooling air 526 towards shroud segment leading edge 133 and to facilitate purging gap 182 of migrating hot gases that have migrated into the gap.

Figure 4 is a schematic plan view of turbine nozzle outer band 183, outer band aft flange 504, gap 182, and shroud assembly leading edge 133. More specifically, as shown in Figure 4, aft flange cooling openings 508 extend obliquely through aft flange 504 and shroud segment leading edge openings 181 extend obliquely through shroud segment leading edge 133. In the exemplary embodiment, each nozzle segment 520 includes at least one airfoil vane 510 that includes a first sidewall 512 and a second sidewall 514. In the exemplary embodiment, first sidewall 512 is convex and defines a suction side of each airfoil vane 510, and second sidewall 514 is concave and defines a pressure side of each airfoil vane 510. Sidewalls 512 and 514 are joined together at a leading edge 516 and at an axially-spaced trailing edge 518 of each airfoil vane 510. Each airfoil trailing edge 518 is spaced chordwise and downstream from each respective airfoil leading edge 516. First and second sidewalls 512 and 514, respectively, extend longitudinally, or radially outwardly, in span from a radially inner band (not shown) to radially outer band 183.

Each vane 510 has airfoil contours (not shown) from leading edge 516 toward trailing edge 518. As the hot combustion gases flow around airfoil vanes 510, the gases along sidewall 512 accelerate and create a lower static pressure, and the gases along sidewall 514 decelerate and create a higher static pressure. During engine operation, hot combustion gases are channeled between vanes 510 and bands 183 and form a pair of passage vortices from sidewall 514 toward sidewall 512 on the surfaces of the inner band (not shown) and outer band 183. The passage vortices bring the hotter combustion gases from the mid-span core flow toward the inner band (not shown) and outer band 183. There are periodic pressure variations along the circumferential direction at the turbine nozzle outer band trailing edge 500. The combination of the passage vortex and the circumferential pressure variation at shroud leading edge 133 result in circumferentially periodic local hot spots 550 developing on shroud inner

214422

surface 138. Over time, such hot spots 550 may reduce an overall performance of the engine assembly and/or reduce a durability of the engine.

Cooling openings 508 are obliquely-oriented in outer band aft flange 504 relative to trailing edge 500 such that cooling flow discharged from openings 508 is discharged at a discharge angle α generally in the direction of rotation indicated by arrow A. In the exemplary embodiment, discharge angle α is oblique and as such is not parallel to a flow of combustor gases through turbines 112 and 114. More specifically, all cooling openings 508 are obliquely-oriented at the same discharge angle α . Alternatively, any of openings 508 may be uniformly obliquely-oriented at any discharge angle α that enables cooling openings 508 to function as described herein. In the exemplary embodiment, openings 508 are spaced circumferentially equidistantly across outer band trailing edge 500. Moreover, in the exemplary embodiment, openings 508 are all sized and obliquely-oriented identically. It should be appreciated that although cooling openings 508 illustrated in the exemplary embodiment are sized identically and are uniformly spaced across trailing edge 500 of turbine nozzle outer band 183, in alternative embodiments, cooling openings 508 may have any size, shape, or orientation that enables cooling openings 508 to function as described herein.

In the exemplary embodiment, cooling openings 181 extend through shroud assembly leading edge 133 and are obliquely-oriented to discharge cooling fluid at a discharge angle β measured with respect to a centerline 555 of gap 182. In the exemplary embodiment, discharge angle β is oblique and as such flow discharged from openings 181 is not parallel to a flow of combustion gases through turbines 112 and 114. More specifically, in the exemplary embodiment, cooling openings 181 are uniformly obliquely-oriented at discharge angle β in the direction of arrow A. Alternatively, any of openings 181 may be uniformly obliquely-oriented at any discharge angle β that enables cooling openings 181 to function as described herein. In the exemplary embodiment, openings 181 are spaced circumferentially equidistantly across shroud assembly leading edge 133. Moreover, in the exemplary embodiment, openings 181 are all sized and oriented identically. It should be appreciated that although cooling

214422

openings 181 illustrated in the exemplary embodiment are sized identically and are uniformly spaced across the leading edge 133 of shroud assembly 110, in alternative embodiments, cooling openings 181 may have any size, shape, or orientation that enables cooling openings 181 to function as described herein.

In the exemplary embodiment, cooling openings 508 are each substantially aligned with a respective one of cooling openings 181 located across gap 182. It should be appreciated that although cooling openings 508 are substantially aligned with respective cooling openings 181 in the exemplary embodiment, in other embodiments, cooling openings 508 are not required to align with respective cooling openings 181, and instead may be offset by any distance from respective cooling openings 181 that enables cooling openings 508 and 181 to function as described herein. Additionally, in the exemplary embodiment, discharge angles α and β have the same magnitude. It should be appreciated that although angles α and β are described as having the same magnitude in the exemplary embodiment, in other embodiments, cooling openings 508 and 181 may be oriented at different angles α and β , respectively.

During operation, the oblique orientation of cooling openings 508 and 181 imparts a clockwise, or tangential, velocity component to air channeled through cooling openings 508 and 181. As a result, cooling flow energy is facilitated to be enhanced because little energy is lost in turning the cooling air through misaligned cooling openings. The clockwise momentum of the air facilitates balancing the pressure distribution inside gap 182, such that hot gas ingestion into gap 182 is reduced.

Moreover, the oblique orientation and location of cooling openings 508 and 181 about turbine nozzle assembly 520 facilitates reducing hot gas ingestion into gap 182 and facilitates improving film cooling across shroud inner surface 138 downstream from leading edge 133. The orientation and location of cooling openings 508 and 181 facilitates increasing the length of cooling openings 508 and 181, thus increasing the convective cooling ability of openings 508 and 181 within each outer band 183 and shroud assembly 110.

The above-described turbine nozzle segments and shroud segments include a plurality of obliquely-oriented cooling holes extending along an aft flange of the turbine nozzle

214422

outer band and along a leading edge of the turbine shroud assembly. More specifically, the cooling holes extend through the aft flange of the outer band, and through the leading edge of the turbine shroud assembly. As a result, cooling air is directed into a gap defined between the aft flange and leading edge to facilitate reducing hot gas ingestion into the gap, and to facilitate efficiently distributing cooling air to areas of the shroud inner surface directly exposed to the hot combustion gases. Accordingly, the turbine nozzle segments and shroud segments are operable at a reduced operating temperature, thus facilitating extending the durability and useful life of the turbine nozzle segments and shroud segments, and reduces the operating cost of the engine.

Exemplary embodiments of turbine nozzle segments and shroud segments are described above in detail. The segments are not limited to the specific embodiments described herein, but rather, components of each segment may be utilized independently and separately from other components described herein.

While there have been described herein what are considered to be preferred and exemplary embodiments of the present invention, other modifications of these embodiments falling within the scope of the invention described herein shall be apparent to those skilled in the art.

214422

What is claimed is:

1. A method of assembling a gas turbine engine, said method comprising:

coupling at least one turbine nozzle segment within the gas turbine engine, wherein the at least one turbine nozzle segment includes at least one airfoil vane extending between an inner band and an outer band that includes an aft flange and a radial inner surface, each turbine nozzle outer band aft flange comprising cooling holes defined therein;

coupling at least one turbine shroud segment downstream from the at least one turbine nozzle segment, wherein the at least one turbine shroud segment includes a leading edge and a radial inner surface, each shroud assembly leading edge comprising cooling holes defined therein; and

coupling a cooling fluid source in flow communication with the at least one turbine nozzle segment such that cooling fluid channeled to each turbine nozzle outer band aft flange is directed at an oblique discharge angle towards the leading edge of the at least one turbine shroud segment, wherein said coupling further comprises positioning each of the cooling holes defined within each turbine nozzle outer band aft flange in substantial alignment with a corresponding cooling hole defined in the shroud assembly leading edge.

2. A method in accordance with claim 1 wherein said coupling a cooling fluid source in flow communication with the at least one turbine nozzle segment further comprises coupling the cooling fluid source to the turbine nozzle segment such that cooling fluid may be channeled into a gap defined between the aft flange and the leading edge.

3. A method in accordance with claim 1 wherein said coupling a cooling fluid source in flow communication with the at least one turbine nozzle segment further comprises coupling the cooling fluid source to the turbine nozzle segment such that cooling fluid is channeled through a portion of the turbine nozzle outer band to facilitate reducing hot gas ingestion into a gap defined between the aft flange and the leading edge.

214422

4. A method in accordance with claim 1 wherein coupling at least one turbine shroud segment downstream from the at least one turbine nozzle segment further comprises positioning the turbine shroud segment such that cooling air discharged through each of the cooling holes defined therein is discharged at an angle that is substantially tangential to a direction of rotation of the turbine nozzle segment.

5. A method in accordance with claim 1 wherein coupling the at least one turbine shroud segment downstream from the at least one turbine nozzle segment further comprises positioning the turbine shroud segment such that cooling air discharged through each of the cooling holes defined within each shroud leading edge is discharged at an angle that is substantially tangential to a direction of rotation of the turbine nozzle segment.

6. An engine assembly comprising:
a nozzle assembly comprising:
an inner band;
an outer band comprising an aft flange and a radial inner surface, said aft flange comprising a plurality of cooling holes configured to direct cooling fluid therefrom at an oblique discharge angle;
a shroud assembly comprising a shroud inner surface and a shroud assembly leading edge, said shroud assembly leading edge comprising a plurality of cooling holes configured to discharge cooling air therefrom at an oblique angle with respect to a centerline of a gap defined between said outer band aft flange and said shroud assembly leading edge wherein each of said outer band plurality of cooling holes is substantially aligned with a respective one of said plurality of cooling holes defined in said shroud assembly leading edge; and
at least one airfoil vane extending between said inner band and said outer band.

7. An engine assembly in accordance with claim 6 wherein each of said outer band plurality of cooling holes and each of said shroud assembly plurality of cooling holes are obliquely-oriented with respect to a direction of rotation of said turbine nozzle segment.

214422

8. An engine assembly in accordance with claim 6 wherein said plurality of outer band aft flange cooling holes facilitate reducing hot gas ingestion into a gap defined between said outer band aft flange and said shroud assembly leading edge.

9. An engine assembly in accordance with claim 6 wherein said plurality of outer band aft flange cooling holes and said plurality of shroud assembly leading edge cooling holes facilitate film cooling of said shroud inner surface.

10. An engine assembly in accordance with claim 7 wherein said plurality of outer band aft flange cooling holes are oriented with a discharge angle that is different than a discharge angle of each of said plurality of shroud assembly leading edge cooling holes.

11. A gas turbine engine comprising:

a nozzle assembly comprising an inner band, an outer band:

at least one airfoil vane extending between said inner band and said outer band,

said outer band comprising an aft flange and a radial inner surface, said aft flange comprising a plurality of cooling holes configured to direct cooling fluid therefrom at an oblique discharge angle; and

a shroud assembly comprising a shroud inner surface and a shroud assembly leading edge, said shroud assembly leading edge comprising a plurality of cooling holes configured to discharge cooling air therefrom at an oblique angle with respect to a centerline of a gap defined between said outer band aft flange and said shroud assembly leading edge, wherein each of said plurality of outer band aft flange cooling holes is substantially aligned with a respective one of said plurality of cooling holes defined in said shroud assembly leading edge.

12. A gas turbine engine in accordance with claim 11 wherein each of said outer band plurality of cooling holes and each of said shroud assembly plurality of cooling holes are obliquely-oriented with respect to a direction of rotation of said turbine nozzle segment.

214422

13. A gas turbine engine in accordance with claim 11 wherein said plurality of outer band aft flange cooling holes facilitate reducing hot gas ingestion into a gap defined between said outer band aft flange and said shroud assembly leading edge.

14. A gas turbine engine in accordance with claim 11 wherein said plurality of outer band aft flange cooling holes and said plurality of shroud assembly leading edge cooling holes facilitate film cooling of said shroud inner surface.

15. A gas turbine engine in accordance with claim 12 wherein said plurality of outer band aft flange cooling holes are oriented with a discharge angle that is different than a discharge angle of each of said shroud assembly leading edge cooling holes.

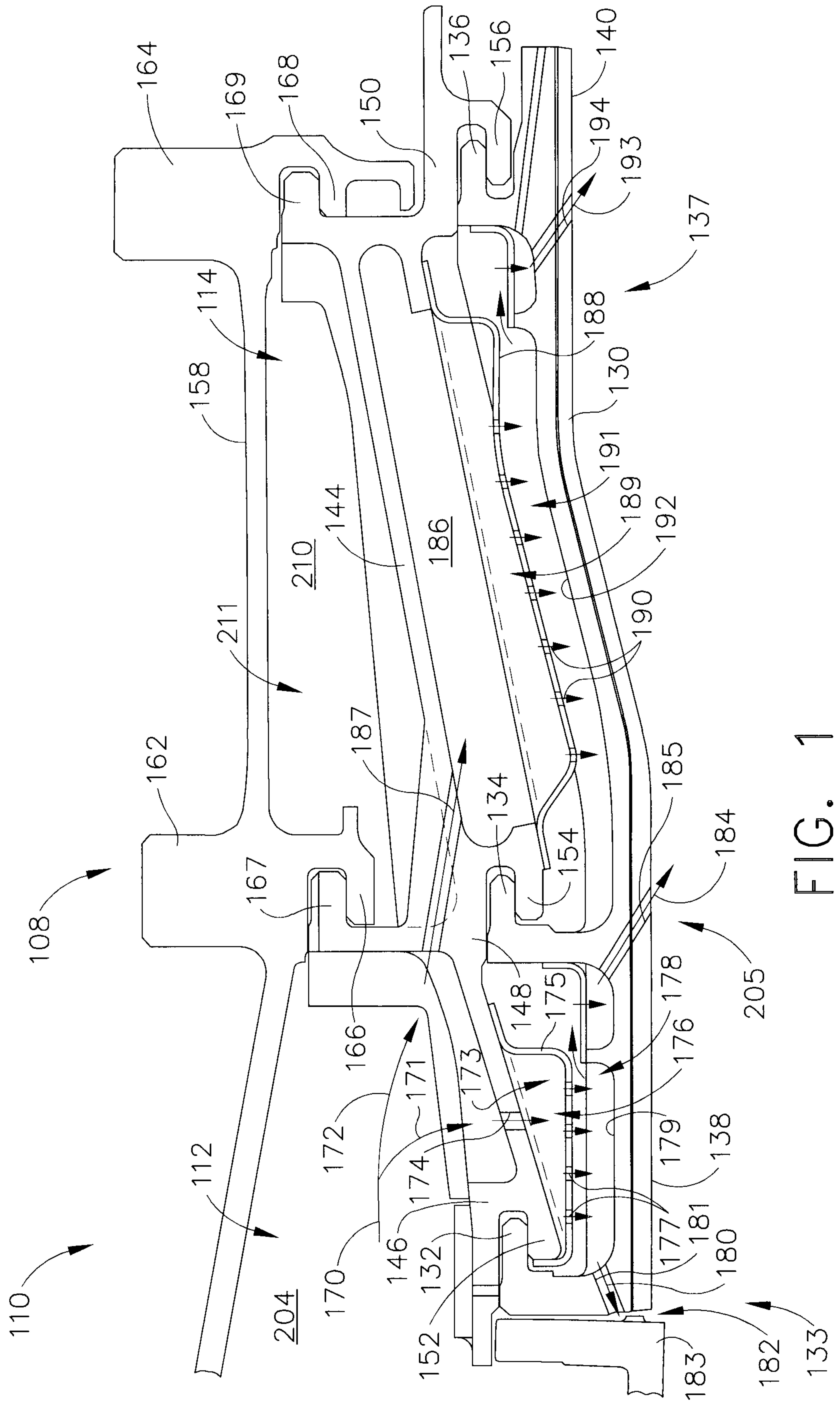

FIG. 1

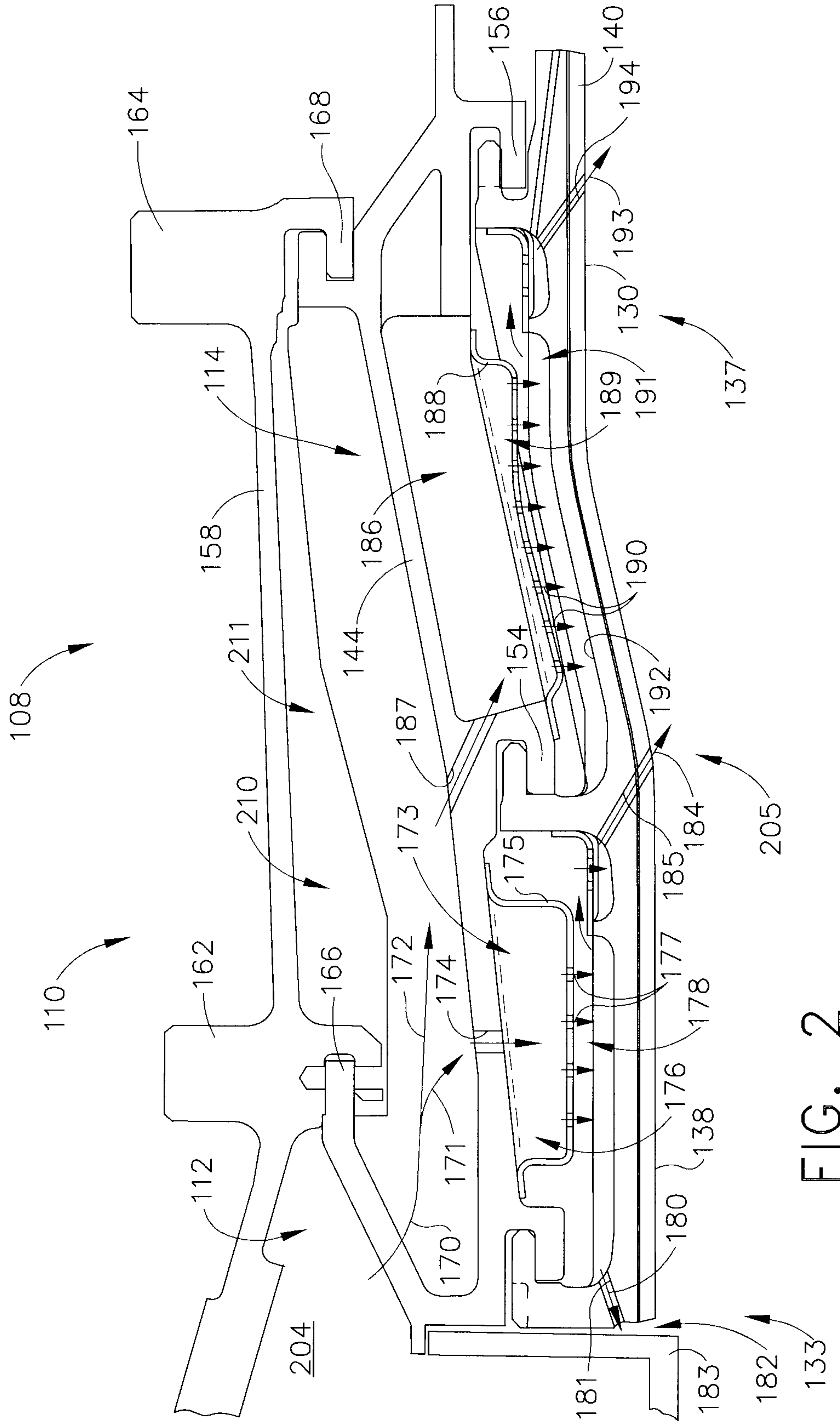

FIG. 2

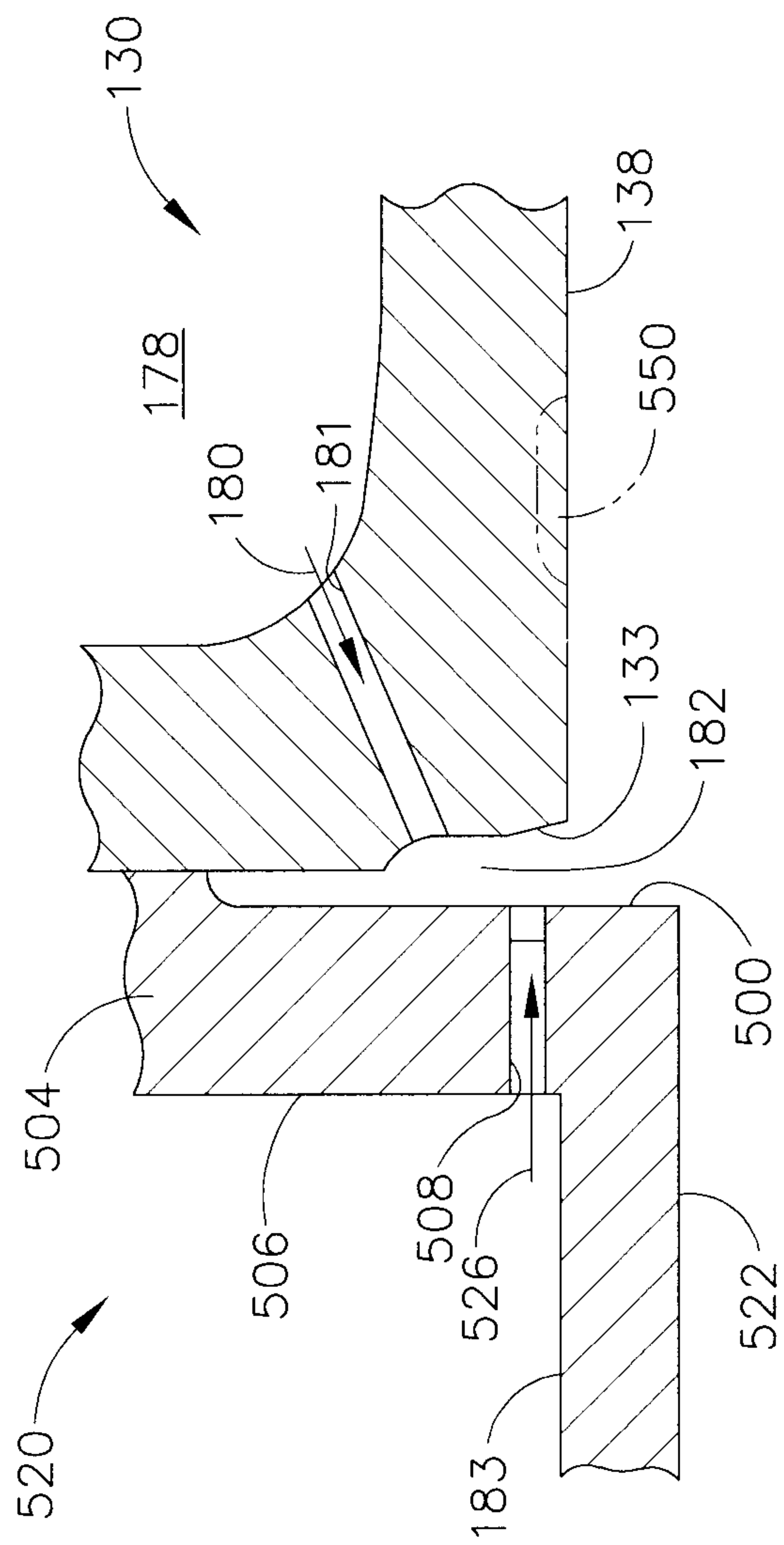

FIG. 3

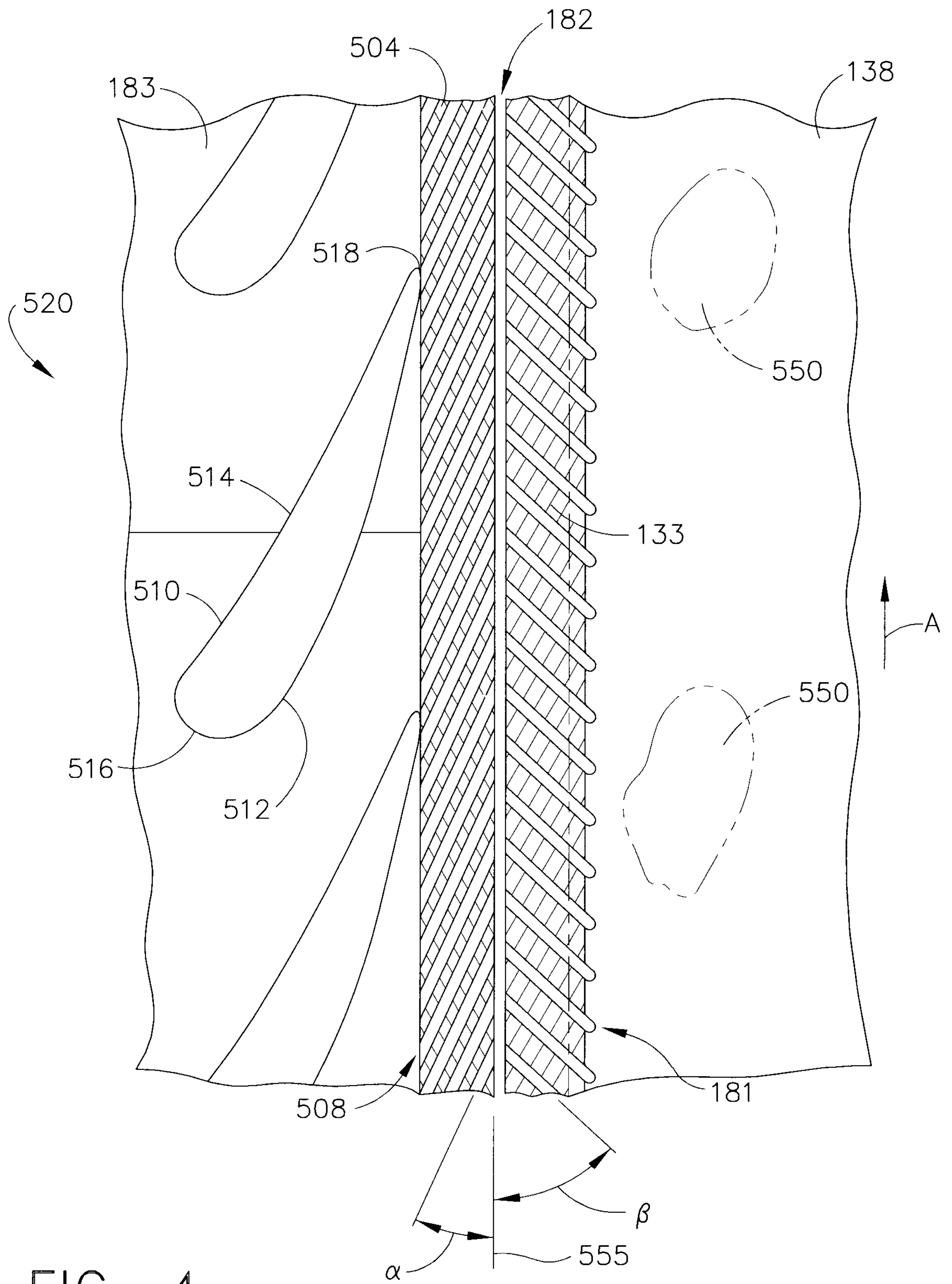

FIG. 4

