

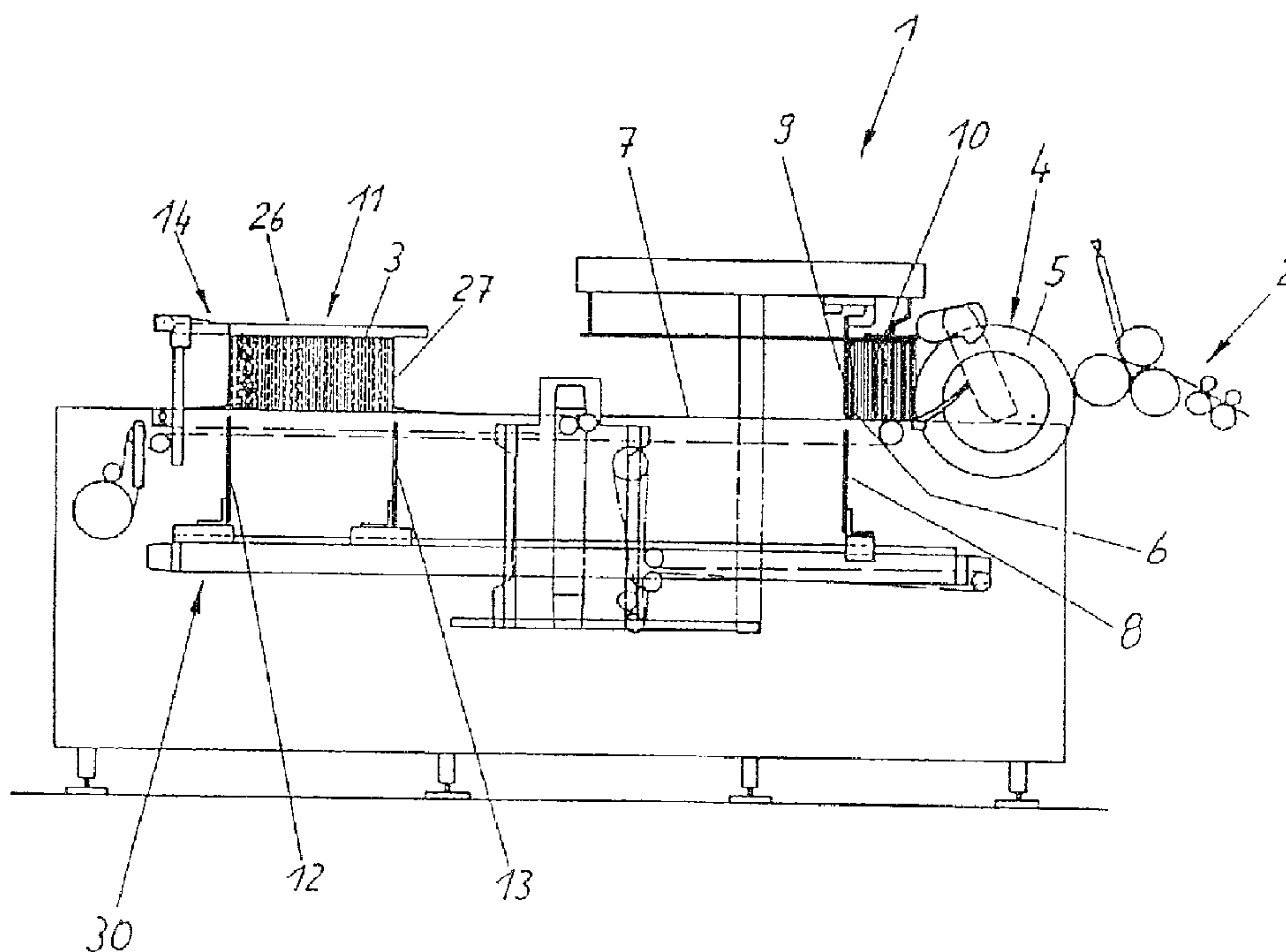

(86) Date de dépôt PCT/PCT Filing Date: 1992/05/19  
 (87) Date publication PCT/PCT Publication Date: 1992/12/10  
 (45) Date de délivrance/Issue Date: 2003/12/30  
 (85) Entrée phase nationale/National Entry: 1993/01/22  
 (86) N° demande PCT/PCT Application No.: EP 1992/001097  
 (87) N° publication PCT/PCT Publication No.: 1992/021599  
 (30) Priorité/Priority: 1991/05/28 (P 41 17 434.8) DE

(51) Cl.Int.<sup>5</sup>/Int.Cl.<sup>5</sup> B65H 33/02  
 (72) Inventeur/Inventor:  
BLUMLE, MARTIN, DE  
 (73) Propriétaire/Owner:  
WINKLER & DUNNEBIER MASCHINENFABRIK UND  
EISENGIESSEREI KG, DE  
 (74) Agent: MACRAE & CO.

(54) Titre : PROCÉDE D'EMPILAGE ET DISPOSITIF  
 (54) Title: STACKING PROCESS AND DEVICE



(57) Abrégé/Abstract:

The invention relates to a process and device for forming, maintaining, separating and transporting stacks, especially stacks (10, 11 or 10a, 11a) of envelopes (3) or the like, behind a delivery device (4, 4a) which lays continuously or individually arriving envelopes (3, 3a) on one of their edges (6, 6a) on a stacking surface (7, 7a). The essence of the invention consists in that: the items to be stacked (3, 3a) are first held at the start of the formation of the stack (10, 10a) by a first front stack support (8, 8a) moving in the direction of the increasingly large stack (10, 10a) (Fig. 4); a second front stack support (9, 9a) then takes the place of the first front stack support (8, 8a) (fig. 6); and after the completion of the stack (10, 11 or 10a, 11a; fig. 2) a third front stack support (12, 12a) and a rear stack support (13, 13a) take the stack (11, 11a) and transport it further; at the same time as the stack (11, 11a) is taken by the third front stack support (12, 12a) and the rear stack support (13, 13a), the first front stack support (8, 8a) together with the rear stack support (13, 13a) acts as a separator between the completed stack (11, 11a) and the parts (3, 3a) of the next stack (10, 10a) to be formed and supports it.

(51) Internationale Patentklassifikation <sup>5</sup> :

B65H 33/02, 29/00

A1

(11) Internationale Veröffentlichungsnummer: WO 92/21599

(43) Internationales  
Veröffentlichungsdatum:

10. Dezember 1992 (10.12.92)

(21) Internationales Aktenzeichen: PCT/EP92/01097

(22) Internationales Anmeldedatum: 19. Mai 1992 (19.05.92)

(30) Prioritätsdaten:  
P 41 17 434.8 28. Mai 1991 (28.05.91) DE(71) Anmelder (für alle Bestimmungsstaaten ausser US): WIN-  
KLER & DÜNNEBIER MASCHINENFABRIK UND  
EISENGIESSEREI KG [DE/DE]; Sohler Weg 65, D-  
5450 Neuwied 1 (DE).(72) Erfinder; und  
(75) Erfinder/Anmelder (nur für US) : BLÜMLE, Martin [DE/  
DE]; Am Tempelsberg 2, D-5451 Horhausen (DE).(74) Anwalt: SCHIEFERDECKER, Lutz; Herrnstr. 37, D-6050  
Offenbach am Main (DE).(81) Bestimmungsstaaten: AT (europäisches Patent), BE (euro-  
päisches Patent), CA, CH (europäisches Patent), DE  
(europäisches Patent), DK (europäisches Patent), ES  
(europäisches Patent), FI, FR (europäisches Patent), GB  
(europäisches Patent), GR (europäisches Patent), IT (eu-  
ropäisches Patent), JP, LU (europäisches Patent), MC  
(europäisches Patent), NL (europäisches Patent), SE (eu-  
ropäisches Patent), US.

Veröffentlicht

Mit internationalem Recherchenbericht.

(54) Title: STACKING PROCESS AND DEVICE

(54) Bezeichnung: VERFAHREN UND VORRICHTUNG ZUM STAPELN

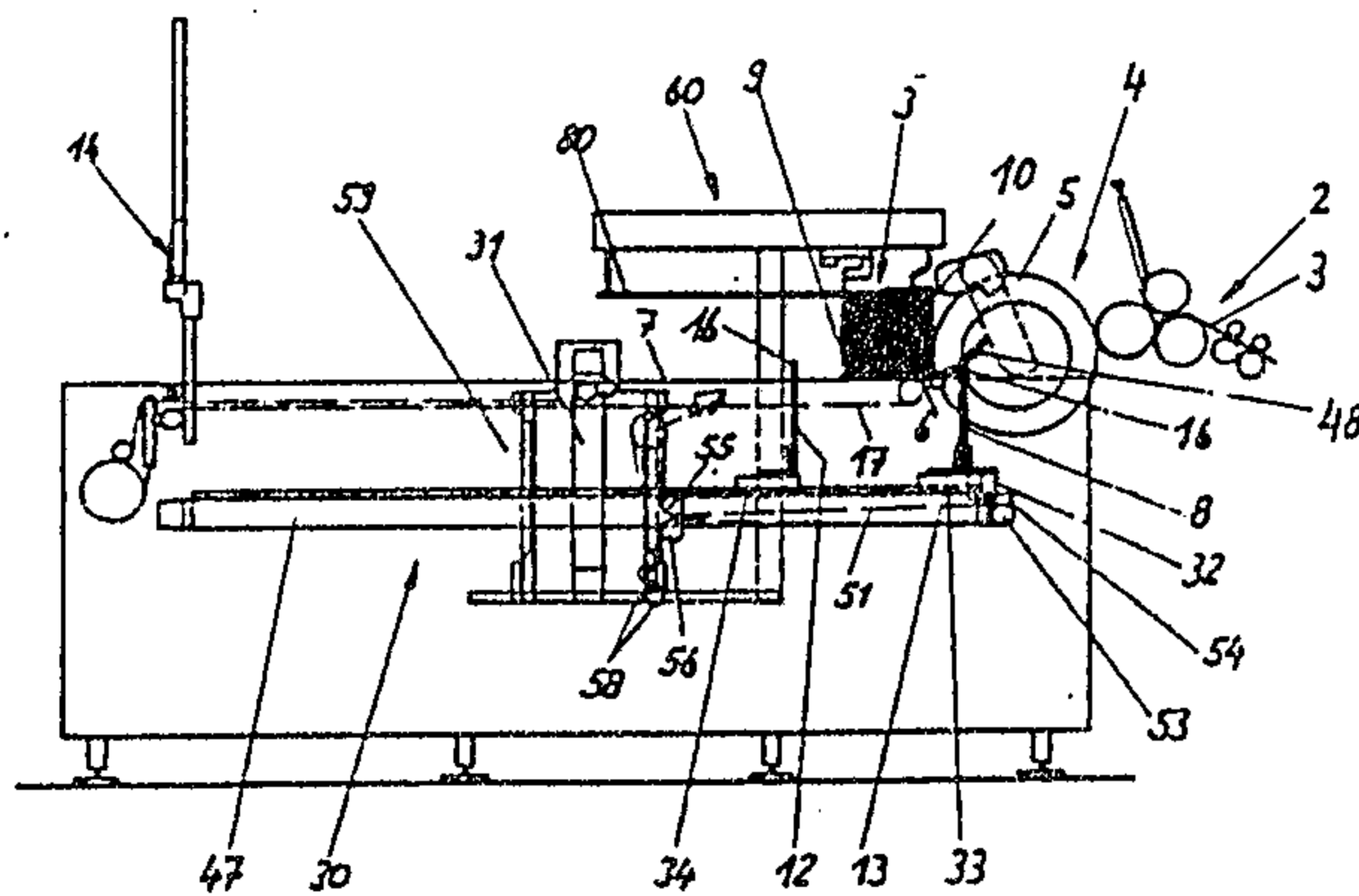

(57) Abstract

The invention relates to a process and device for forming, maintaining, separating and transporting stacks, especially stacks (10, 11 or 10a, 11a) of envelopes (3) or the like, behind a delivery device (4, 4a) which lays continuously or individually arriving envelopes (3, 3a) on one of their edges (6, 6a) on a stacking surface (7, 7a). The essence of the invention consists in that: the items to be stacked (3, 3a) are first held at the start of the formation of the stack (10, 10a) by a first front stack support (8, 8a) moving in the direction of the increasingly large stack (10, 10a) (Fig. 4); a second front stack support (9, 9a) then takes the place of the first front stack support (8, 8a) (fig. 6); and after the completion of the stack (10, 11 or 10a, 11a; fig. 2) a third front stack support (12, 12a) and a rear stack support (13, 13a) take the stack (11, 11a) and transport it further; at the same time as the stack (11, 11a) is taken by the third front stack support (12, 12a) and the rear stack support (13, 13a), the first front stack support (8, 8a) together with the rear stack support (13, 13a) acts as a separator between the completed stack (11, 11a) and the parts (3, 3a) of the next stack (10, 10a) to be formed and supports it.

1 METHOD AND APPARATUS FOR STACKING

SPECIFICATION

The invention relates to a method and to an apparatus for stacking that is, for forming, holding, separating, and transporting of stacks, especially stacks made up of letter envelopes or the like downstream of a depositing mechanism which deposits continuously and individually arriving letter envelopes with one envelope edge on a stacking surface.

10 A method and an apparatus of the type mentioned are known. The apparatus has a forward stack holder and a rear stack holder, whereby the forward stack holder functions as a holding element during the stack formation while the rear stack holder separates the completed stack from the next stack. The rear stack forms together with the forward stack a transport unit. This known apparatus functions basically in a satisfactory manner. The invention, however, is based on the problem to further improve this technology and to make it more efficient.

20 To solve this problem the invention provides that during the removing transport of one stack and the simultaneous formation of the next new stack, simultaneously several stack holders are operational and are being moved into the movement path of the stack and out of the movement path as well as alongside the movement path.

1 Contrary to the prior art, the invention provides not only two  
stack holders that simultaneously function as transport unit,  
rather, the invention provides further also movable stack holders.  
These further stack holders are, just as the stack holders serving  
as a transport unit, movable into the motion or movement path of the stack  
and out of the movement path as well as alongside the movement  
path of the stack, whereby, however, the movement along the movement  
path is limited only to the area of the stack formation. The  
stack holders that are only movable in the area of the stack for-  
10 mation are further effective until their function is taken over  
by the two other stack holders that serve simultaneously as a  
transport unit.

According to one example embodiment, three stack holders are moved  
from one side across the movement path and alongside the movement  
path of the stack while a fourth stack holder is moved from a  
second side into the movement path and out of the movement path  
as well as temporarily along the movement path during the stack  
formation. Thereby, the motion of the three stack holders takes  
place preferably from below upwardly as well as back and in the  
20 longitudinal direction of the motion path, while the motion of  
the single stack holder takes place from above downwardly and  
back as well as in the direction of the motion path of the stacks.

Since the stack holders become effective partially simultaneously  
and partially in alternation, and since they supplement each other,  
a continuous motion sequence is possible without interruption,  
whereby the stack formation also takes place continuously and  
with an altogether small individual velocity of the separate com-  
ponents. Connected therewith is a high degree of operational

reliability and hence a small susceptibility to trouble.

Accordingly, there is provided in one aspect of the invention a method for forming, holding, separating, and transporting stacks of articles downstream of a depositing mechanism which deposits continuously and individually arriving articles with an article edge on a stacking surface to form the stacks. The transporting takes place in a transport direction from the depositing mechanism to a packing station and the stack has several sides extending in parallel to the transport direction. The method comprising the following steps:

(a) first holding articles at the beginning of a stack formation by a first leading stack holder which moves in the transport direction in which a stack size increases;

(b) second holding a partly formed stack by a second leading stack holder which takes over the partly formed stack from the first leading stack holder while the second leading stack holder is also moving in the transport direction;

20 (c) engaging a leading end of a completed stack by a third leading stack holder and engaging a rear end of the completed stack by a rear fourth stack holder for further transporting the completed stack in the transport direction toward the packing station;

(d) simultaneously with the engaging of the completed stack by the third leading stack holder and by the rear fourth stack holder, separating the completed stack from a next stack being formed, by entering the first leading stack holder and the rear fourth stack holder between the  
30 completed stack and the next stack;

(e) supporting the next stack by the first leading stack holder and by the rear fourth stack holder;

(f) moving any three stack holders of the four stack holders crosswise to the transport direction from one stack side of the several sides of the stack and also moving the any three stack holders alongside the transport direction for the transporting of a stack; and

10 (g) moving any one stack holder of the four stack holders crosswise to the transport direction from another stack side and also moving the any one stack holder temporarily in the transport direction and then opposite the transport direction back to a starting position.

In accordance with a further aspect of the invention, there is provided an apparatus for forming, holding, separating and transporting stacks of articles downstream of a depositing mechanism which deposits continuously and individually arriving articles with an article edge, comprising a stacking surface leading in a transport direction from the depositing mechanism to a packing station, the stacking surface forming a stacking level on 20 which articles are deposited, the apparatus further comprising four movable stack holders for holding an article on the stacking surface, drive means connected to the four stack holders for operating the stack holders, the movable stack holders comprising three leading stack holders and one rear stack holder, the drive means comprising first drives adapted for moving the three leading stack holders crosswise of the transport direction and in parallel to the transport direction, the drive means further comprising a second drive 30 adapted for moving the rear stack holder crosswise of the

transport direction and in the transport direction for holding a stack during its formation and for transporting a completed stack, the first drives, two of the three leading stack holders, and the rear stack holder being arranged for moving the two leading stack holders and the rear stack holder from one and the same side of a stack crosswise to the transport direction and in parallel to the transport direction, and wherein the second drive and the third of the three leading stack holders are arranged for moving from  
10 another side of a stack crosswise to the transport direction and in parallel to the transport direction, whereby a stack is positively held and guided during its formation and during its transportation.

Further features of the invention are set forth in the claims in conjunction with the description and the drawing. The invention will be described more detail in the following with reference to example embodiments which are shown in the drawing, wherein:

Fig. 1 is a schematic side view of the present apparatus for  
20 stacking showing a partially completed stack;

Fig. 2 is a view as in Fig. 1 but with a completed stack and with stack holders forming a transport unit in a position prior to taking over the completed stack;

Fig. 3 is a view as in Fig. 2, showing the stack holders forming the transport unit after they have taken over the completed stack;

Fig. 4 is a view as in FIGS. 1 to 3, with a completed stack being transported away and with a further stack being formed anew;

Fig. 5 is a view as in FIGS. 1 to 4, showing the finished stack completely transported away and the further stack still in its state of being formed, whereby the stack is only held by its first forward stack holder;

Fig. 6 is a view similar to Fig. 5 showing the stack being formed, held by the second forward stack holder;

10 Fig. 7 is a view similar to Fig. 6, whereby the stack being formed is held by its second forward stack holder, while the other stack holders are in a withdrawn waiting position out of which they move into a ready position;

Fig. 8 shows, on an enlarged scale compared to Fig. 1, a side view of the mounting and of the drive of the second forward stack holder;

Fig. 9 shows details of the second forward stack holder;

Fig. 10 is a plan view of the mounting of the first forward stack holder and of the rear stack holder;

20 Fig. 11 is a side view of the first forward stack holder and of the rear stack holder;

Fig. 12 shows, on a larger scale, details of the mounting of the first forward stack holder;

Fig. 13 is a view as in Fig. 5 of a modified embodiment; and

Fig. 14 is a view as in Fig. 6 of the embodiment according to Fig. 13.

## DETAILED DESCRIPTION OF PREFERRED EXAMPLE EMBODIMENTS

A stacking machine 1 for stacking of letter envelopes 3 coming, for example, from a feeding station 2, comprises according to Fig. 5 a depositing mechanism 4 having compartment disks 5. The feeding station 2 and the depositing mechanism 4 are basically known and not part of the invention.

As further shown in Fig. 5, the continuously and individually arriving letter envelopes 3 are deposited with one of their edges 6 by the depositing mechanism 4 on a stacking surface 7 of the stacking machine 1, where, the envelopes are held initially by a first forward stack holder 8. The term "forward" stack holder 8 means that this stack holder 8 is located forward in the direction of the stack formation, that is in the direction of the arrow a in Fig. 5.

As soon as the stack 10 has reached a predetermined size (Fig. 6), a second forward stack holder 9 takes up the position of the first forward stack holder 8 and holds the stack being formed so that the first forward stack holder 8 can be moved out of the movement path of the stack 10 being formed. This is also shown in Fig. 6.

When, finally, the stack 10 being formed has become a complete stack 11 according to Fig. 2, the third forward stack holder 12 and a rear stack holder 13, as viewed in the transport direction, take over the stack 11. The two stack holders 12 and 13 form

1 together a transport unit and transport the completed stack 11 out of the zone of the stack formation, for example, to a turn-over and packaging station 14 as is shown in Figs. 2 to 5 or 6.

When the two stack holders 12 and 13 serving as a transport unit take over the stack 11, the first forward stack holder 8 is simultaneously moved in front of the next part to be stacked. Thus, the first forward stack holder 8 serves simultaneously as a separation element between a finished, completed stack 11 and the next stack 10 being formed (Figs. 2 and 3).

10 For forming, holding, separating, and transporting of stacks 10, 11 there are thus several, that is concretely four stack holders 8, 9 and 12, 13 active and move into the motion path of the stacks 10, 11 as well as out of the motion path thereof and they move alongside the motion path of the stacks 10, 11. Three stack holders 8, 12, and 13 move from one side across the motion path of the stacks 10, 11, and alongside of the motion path, whereas the fourth stack holder 9 moves from a second side into the motion path and out of the motion path again as well as at certain times during the stack formation alongside the motion path.

20 According to the example embodiment shown in Figs. 1 to 7, the second forward stack holder 9 is tilted from above in front of a stack being formed, and moves during the stack formation along the motion path of the stack 10 until the stack holder is tilted again upwardly and then moves backward in the direction of the depositing mechanism.

1 The individual figures show the different process steps as follows.

According to Fig. 1, the second forward stack holder 9 holds the stack 10 being formed while the stack holders 12 and 13 serving as a transport unit are in a ready position just as the first forward stack holder 8. In this ready position, the stack holders 8 and 30 are located with a slight spacing in front of the stack 10 on its side facing the depositing mechanism 4 and extend with their free ends 16 slightly above the stack surface 7.

10 In Fig. 2, the stack 11 has reached its full size. The second forward stack holder 9 and the third forward stack holder 12 that forms part of the transport unit, are positioned in one plane. The rear stack holder 13 and the immediately next to it located first forward stack holder 18 have moved out of the ready position of Fig. 1 into contact with the last member 15 of the complete stack 11. This takes place on a relatively low level so that initially, the forward stack holder 12, as well as the rear stack holder 13, rest against the outside of the stack 11 only with their upper ends 16.

20 As shown in Fig. 3, then the two stack holders 12 and 13 move along the stack upwardly and simultaneously somewhat in the movement direction of the stack 11 to be transported away.

The stack 10 or 11 rests in the stack formation area suitably on the upper run of a conveyor belt 17 running around guide rollers 18 to 23 and around one driving and guide roller 24.

1 The transport speed of the two stack holders 12 and 13 forming  
the transport unit is larger than the transport speed of the con-  
veyor belt 17 so that quickly a gap 25 is formed relative to the  
next stack 10 being formed (Fig. 4). This next stack 10 being  
formed is held by the first forward stack holder 8 which has been  
moved together with the rear stack holder 50 out of the ready  
position according to Fig. 1 after completion of the stack 10  
according to Fig. 2, into contact with the last member 15 of the  
stack, whereby this movement initially also takes place on a low  
10 level. Thereafter, the first forward stack holder 8 is moved  
crosswise to the stack direction out of the position of Fig. 2  
into the support position of Fig. 3. Further, when the third  
forward stack holder 12 has reached its upper position of Fig. 3,  
the second forward stack holder 9 is moved out of the motion path  
of the stack 11. At this stage, the stack holder 9 tilts out  
of the motion path of the stack 11 (Fig. 4).

According to Fig. 5 the two transport stack holders 12 and 13  
have reached with the stack 11 the turnover and packaging station 14.  
During this time, the stack 10 being formed has grown in size.

20 Fig. 6 shows the situation in which the turnover and packaging  
station 14 has taken over the stack 11 by its turnover fork 26.  
Further, a folding box 27 has already been pushed over the stack 11.  
Thus, the stack holders 12 and 13 serving as a transport unit,  
can release themselves from the stack 11. For this purpose, they  
are pulled away from the stack. This takes place according to  
the example embodiment downwardly by lowering the two stack  
holders 12 and 13.

1 However, prior to that, the second forward stack holder 9 which is tiltable inwardly from above has taken over the securing of the stack being formed as shown by comparing of Figs. 5 and 6. With the lowering of the two stack holders 12 and 13, the first forward stack holder 8 is also lowered according to the example embodiment so that it can no longer hold the stack being formed (Fig. 6).

10 Thereafter, the three stack holders 8, 12, and 13 that are movable from the same side across the motion path of the stacks 10, 11 move from the position in the left side of Fig. 6 into a waiting position on the right side in Fig. 7. In this waiting position, the free end 16 of the stack holders 8, 12, and 13 are still below the stacking surface 7 at a level onto which they are moved back after the lowering shown in Fig. 6 into a position according to Fig. 7. From this lowered level below the stacking surface 7, the stack holders 8, 12, and 13 are then lifted again into the ready position until they extend with their upper free end 16 somewhat above the level of the stacking surface 7 as is shown in Fig. 1. Thereafter, the above described process steps are  
20 being repeated.

A mechanism 30 serves for mounting and driving the first forward stack holder 8 and the stack holders 12 and 13 serving as a transport unit. The mechanism 30 can be lowered with the aid of a stroke device 31 shown only symbolically in the figures, said lowering taking place from the lifted position of Fig. 1 into the position of Fig. 6. The mechanism 30 comprises means for mounting and guiding, as well as driving the stack holders 8, 12, and 13.

1 The first forward stack holder 8 as well as the two stack holders 12  
and 13 forming a transport unit are each arranged on a slide 32  
or 33 and 34 (Fig. 1). The mechanism 30 according to the example  
embodiment comprises outwardly positioned guide rods 35 and 36  
(Fig. 10) for mounting and guiding the slides 32 of the stack  
holder 8. The mechanism 30 comprises inwardly located guide rods 37  
and 38 for mounting and guiding the two other stack holders 12  
and 13, whereby in Fig. 10 only the slide 33 with the stack holder 13  
is shown, while the slide 34 with the stack holder 12 is not also  
10 shown. The pairs of guide rods 35, 36, as well as 37 and 38 are  
located preferably at different elevations as is seen in Fig. 11.

The rear stack holder 13 as well as the first forward stack holder 8  
which functions with the rear stack holder 13 as a separation  
element, comprise each, for example, four elongated finger type  
elements 39 or 40, which form in turn with the aid of angle irons  
41 and 42, and guide bushings 43 or 44 the slides 32 and 33 accord-  
ing to Figs. 10 and 11. The guide bushings 43 or 44 are mounted  
on guide rods 35 to 38 at the ends of the angle irons 41 and 42.

20 Further, an electromagnetic clutch 45 is secured to the slide 32  
with the aid of a bracket 46. This is shown symbolically in  
Figs. 10 and 12. Further, the slide 33 of the rear stack holder 13  
carries a steel plate 47 (Fig. 12) provided for the electromagnetic  
clutch 45. The two slides 32 and 33 are thus temporarily connected  
to each other by the holding force of the electromagnetic clutch 45.

The connection of the two slides 32 and 33 and thus the synchronous  
and movement in unison of the rear stack holder 13 and of the first

1 forward stack holder 8 which simultaneously forms therewith a  
separation element, is important when these stack holders 8 and  
13 are moved very rapidly out of the ready position according  
to Fig. 1 into the separating position according to Fig. 2. Such  
movement is approximately instantaneous, whereby this movement  
must take place exactly between two parts to be stacked. Upon  
reaching the separation position according to Fig. 2, the two  
stack holders 8 and 13 still move in unison crosswise to the motion  
path of the stack 11. However, now a separation of the two stack  
10 holders 8 and 13 takes place. The stack holders 13 must only  
hold still the completed stack 11 during its transport to the  
turnover and packaging station 14, while the first forward stack  
holder 8 prevents falling over of the next parts deposited by  
the depositing mechanism 4.

The release of the two slides 32 and 33 within the range of their  
electromagnetic clutch 45 for separating the two stack holders 8  
and 13 from each other, takes place with the aid of switches which  
are not shown in the Figures, and which may be controlled by the  
slides themselves.

20 The mechanism 30 further comprises a piston cylinder unit 47 which  
may, for example, be a cylinder without a piston rod, the piston  
of which, which is not shown in the Figures, moves the two stack  
holders 8 and 13 instantaneously out of the waiting position  
according to Fig. 1, into the separation position according to  
Fig. 2. The free ends 16 of the two stack holders 8 and 13 are  
located in the waiting position according to Fig. 1, already within  
the radius of the compartment disk 5 in the plane of the deposit

1 support 48 of the depositing mechanism 4 as also shown in Fig. 1. Additionally, the mechanism 30 is slightly lifted by the stroke device 31.

The transport of the stack 11 out of the position of Fig. 2 or 3 all the way to the turning and packaging station 14 takes place with the aid of the piston cylinder device 47 which is connected with the rear stack holder 13 to displace the same.

10 The piston cylinder device 47 moves the rear stack holder 13 back again into the starting position or waiting position according to Fig. 7, whereby the slide 32 of the first front stack holder 8 is coupled with the slide 33 of the rear stack holder 13 with the aid of the electromagnetic clutch 45. The stack holder 12 belonging to the transport unit receives its drive for the rearward motion from a return spring which is not shown in the figures for clarity's sake.

20 A gear belt 51 (Figs. 10 and 11) is provided for the slide 32 of the first forward stack holder 8. The gear belt 51 is driven synchronously with the conveyor belt 17 (Fig. 3). This gear belt 51 is coupled with the slide 32 or decoupled therefrom by a clamping cylinder of a pneumatic clutch 52. This is necessary because the slide 32 is temporarily coupled through the electromagnetic clutch 45 with the slide 33, which then moves the slide 32.

The gear belt 51 is guided with the aid of a guide roller 53 at the free end 54 of the mechanism 47 (Fig. 1), and further runs over the guide rollers 55 and 56 which are mounted on the piston

1 cylinder device 47 or which are elevationally adjustable together therewith. Further, the gear belt 51 is guided over the guide rollers 57 and 58 which are mounted on a carrier and guide device 59 (Fig. 1) for the mechanism 30 with the piston cylinder device 47.

For the tilting and horizontal movement of the second forward stack holder 9, which is tiltable from above into a position in front of the stack 10 being formed, there is provided a guide and holding mechanism 60, the essential details of which are shown in Figs. 8 and 9.

10 The stack holder 9 comprises, just as the stack holder 12, several, preferably four elongated, finger-type elements 61 which are arranged on a carrier 62. The elements 61 and the carrier 62 are tiltably mounted on arms 63 of a slide 64 for tilting about an axis 65. The slide 64 is displaceable along guide rods 66 which are part of the guiding and holding mechanism 60.

A gear belt 69 is provided for driving the slide 64, one end of which runs around a drive wheel 67 and which is guided around a guide wheel 68. The gear belt 69 can be coupled or decoupled from the slide 64. For this purpose, again a pneumatic clutch 70  
20 is provided which is only schematically indicated at the slide 64 in Fig. 8. The gear belt 69 is, in principle, driven in synchronism with the conveyor belt 17 so that a release from the gear belt 69 is necessary when the stack holder 9 or the slide 64 carrying the stack holder 9 are being moved back into the starting position according to Figs. 4 and 5.

1 A roll up spring 71 is provided for pulling back the slide 64. The roll up spring 71 is connected with its one end 72 in the area of the drive wheel 67 to the guiding and holding mechanism 60 and is further guided around a roll up spring drum 73 which is mounted on the slide 64.

A tilting cylinder 74 serves for tilting the stack holder 9. A piston rod 75 of the cylinder 74 is pivoted to an arm 76 of the carrier 62. A second arm 77 serves as a carrier for the tilting cylinder 74 and connects the latter with the slide 64.

10 The guiding and holding mechanism 60 further comprises finally an upper stack guide element 80 (Fig. 1, 8) which is carried by guide rods 81 that are vertically adjustable. The finger-type element 61 of the stack holder 9 reach through the stack guide element 80.

Figs. 13 and 14 show a modified apparatus 1a for stacking or rather forming, holding, separating, and transporting of stacks 10a or 11a, whereby the same reference numbers serve for designating the same components, however with the index a.

20 The apparatus 1a of Figs. 13 and 14 differs from the stacking machine 1 described first, only in that the second stack holder 9a on a slide 64a is not tiltable, rather it is movable perpendicularly to the stacking surface 7a. The second forward stack holder 9a is mounted for movement in a vertical direction and it is further displaceable with the aid of the slide 64a parallel to the stack 10a as the latter grows in size.

1 The mounting and the drive for the slide 64a in the guiding and holding mechanism 60a may in principle be constructed exactly as described with reference to the first example embodiment. A difference thus exists only as far as the slide 64a carries a stroke mechanism 90a, for example, in the form of a piston cylinder device by means of which the second forward stack holder 9a is lifted when necessary as is shown in Fig. 13 or is lowered as is shown in Fig. 14. The slide 64a comprises for this purpose, a carrier 91a extending upwardly. The piston cylinder  
10 device 90a is connected to the upper end of the carrier. An entraining dog 93a connects the free end of the piston rod 92a with the second forward stack holder 9a. Preferably, the piston rod is guided and supported in the slide 64a.

The function and operation of the guiding and holding mechanism 60a with the second forward stack holder 9a that is movable parallel and vertically relative to the stacking surface 7a does not differ from that of the first described example embodiment when cooperating with the first forward stack holder 8a and the two other stack holders 12a or 13a. As long as the stack  
20 holder 8a according to Fig. 13 holds the stack 10a, the stack holder 9a is in a lifted position. When the two stack holders 12a and 13 release the stack 11a and are lowered for this purpose, the stack holder 8a also releases the stack 10a newly being formed, because it is lowered together with the two other stack holders 12a and 13a. Simultaneously, the stack holder 9a takes over the function of holding the stack 10a. For this purpose, the stroke mechanism 10a shifts the stack holder 9a in front of the stack 10a as is shown in Fig. 14.

1 The three stack holders 8, 12, and 13 or 8a, 12a and 13a move in unison respectively in a vertical direction or perpendicularly to the stacking surface 7 or 7a and in the horizontal direction only partially in unison, namely when especially the two stack holders 8 and 13 or 8a and 13a are moving out of the waiting position according to Fig. 7 into the ready position according to Fig. 1 and then through the separation position according to Fig. 2 into the transport and take over position according to Fig. 3. During the subsequent motion sequences until the wait-

10 ing position is reached, the stack holders 8, 12, and 13 or 8a, 12a, and 13a move substantially independently of one another.

- 17 -

THE EMBODIMENTS OF THE INVENTION IN WHICH AN EXCLUSIVE PROPERTY OR PRIVILEGE IS CLAIMED ARE DEFINES AS FOLLOWS:

1. A method for forming, holding, separating, and transporting stacks (10, 10a; 11, 11a) of articles (3, 3a) downstream of a depositing mechanism (4, 4a) which deposits continuously and individually arriving articles with an article edge (6, 6a) on a stacking surface (7, 7a) to form said stacks, said transporting taking place in a transport direction (a) from said depositing mechanism to a packing station (14), said stack having several sides extending in parallel to said transport direction, said method comprising the following steps:

(a) first holding articles at the beginning of a stack formation by a first leading stack holder (8, 8a) which moves in said transport direction in which a stack size increases;

(b) second holding a partly formed stack by a second leading stack holder (9, 9a) which takes over said partly formed stack from said first leading stack holder (8, 8a) while said second leading stack holder (9, 9a) is also moving in said transport direction;

(c) engaging a leading end of a completed stack (11, 11a) by a third leading stack holder (12, 12a) and engaging a rear end of said completed stack by a rear fourth stack holder (13, 13a) for further transporting said completed stack (11, 11a) in said transport direction (a) toward said packing station (14);

(d) simultaneously with said engaging of the completed stack (11, 11a) by said third leading stack holder (12, 12a) and by said rear fourth stack holder (13, 13a), separating said completed stack (11, 11a) from a next stack (10) being formed, by entering said first leading stack holder (8, 8a) and said rear fourth stack holder (13, 13a) between said completed stack (11, 11a) and said next stack (10, 10a);

(e) supporting said next stack by said first leading

- 18 -

stack holder (8, 8a) and by said rear fourth stack holder (13, 13a);

(f) moving any three stack holders (8, 8a; 12, 12a; 13, 13a) of said four stack holders crosswise to said transport direction (a) from one stack side of said several sides of said stack and also moving said any three stack holders alongside said transport direction for said transporting of a stack; and

(g) moving any one stack holder (9, 9a) of said four stack holders crosswise to said transport direction from another stack side and also moving said any one stack holder (9, 9a) temporarily in said transport direction and then opposite said transport direction back to a starting position.

2. The method of claim 1, wherein any two of said three leading stack holders and said rear stack holder form said any three stack holders for performing said moving of said step (f); and wherein said any one stack holder (9, 9a) is the third of said three stack holders for performing said moving of said step (g).

3. The method of claim 1, further comprising forming a transport unit of said rear stack holder (13, 13a) and of one (12, 12a) of said three leading stack holders, sequentially operating the other two leading stack holders (8, 8a; 9, 9a) for holding a next stack being formed until the next stack is complete, and then moving said transport unit (12, 12a; 13, 13a) to take over a completed stack and to bring said completed stack to said packing station (14).

4. An apparatus for forming, holding, separating and transporting stacks of articles (3, 3a) downstream of a depositing mechanism (4, 4a) which deposits continuously and individually arriving articles with an article edge,

- 19 -

comprising a stacking surface (7, 7a) leading in a transport direction from said depositing mechanism (4, 4a) to a packing station (14), said stacking surface forming a stacking level on which articles are deposited, said apparatus further comprising four movable stack holders for holding an article on said stacking surface, drive means connected to said four stack holders for operating said stack holders, said movable stack holders comprising three leading stack holders (8, 9, 12 or 8a, 9a, 12a) and one rear stack holder (13, 13a), said drive means comprising first drives adapted for moving said three leading stack holders crosswise of said transport direction (a) and in parallel to said transport direction, said drive means further comprising a second drive adapted for moving said rear stack holder (13, 13a) crosswise of said transport direction and in said transport direction for holding a stack during its formation and for transporting a completed stack, said first drives, two of said three leading stack holders (8, 8a; 12, 12a), and said rear stack holder (13, 13a) being arranged for moving said two leading stack holders and said rear stack holder from one and the same side of a stack crosswise to said transport direction and in parallel to said transport direction, and wherein said second drive and the third of said three leading stack holders are arranged for moving from another side of a stack crosswise to said transport direction and in parallel to said transport direction, whereby a stack is positively held and guided during its formation and during its transportation.

5. The apparatus of claim 4, wherein three of said four stack holders (8, 12 and 13 or 8a, 12a and 13a) are mounted below said stacking surface (7, 7a), and wherein one stack holder (9, 9a) of said four stack holders is mounted above a stack (10, 11 or 10a, 11a).

- 20 -

6. The apparatus of claim 5, wherein said one stack holder (9) mounted above the stack (10, 11) is supported in a tiltable manner crosswise to said transport direction and in a slidable manner in said transport direction.

7. The apparatus of claim 5, wherein said three stack holders (8, 12 and 13 or 8a, 12a and 13a) mounted below said stacking surface are mounted on slides (32, 33, 34) movable in said transport direction, said first drive comprising a stroke mechanism (31) for moving said three stack holders in unison crosswise to said transport direction.

8. The apparatus of claim 4, wherein one stack holder (9, 9a) of said three leading stack holders is tiltable from above into a position in front of a stack being formed, said tilting being directed toward another leading stack holder (8, 8a) that is movable from below said stacking surface in front of the stack (10, 10a), said one stack holder being also movable during a stack formation alongside said transport direction, said one stack holder (9, 9a) being further tiltable upwardly and then movable opposite said transport direction toward said depositing mechanism (4, 4a).

9. The apparatus of claim 4, wherein one stack holder (9a) of said three leading stack holders is movable parallel and vertically relative to said stacking surface (7a).

10. The apparatus of claim 4, wherein said first leading stack holder (8) and said rear stack holder (13) are movable into and out of a travel path of a stack in synchronism with each other.

Fig. 1

1/14

2087964

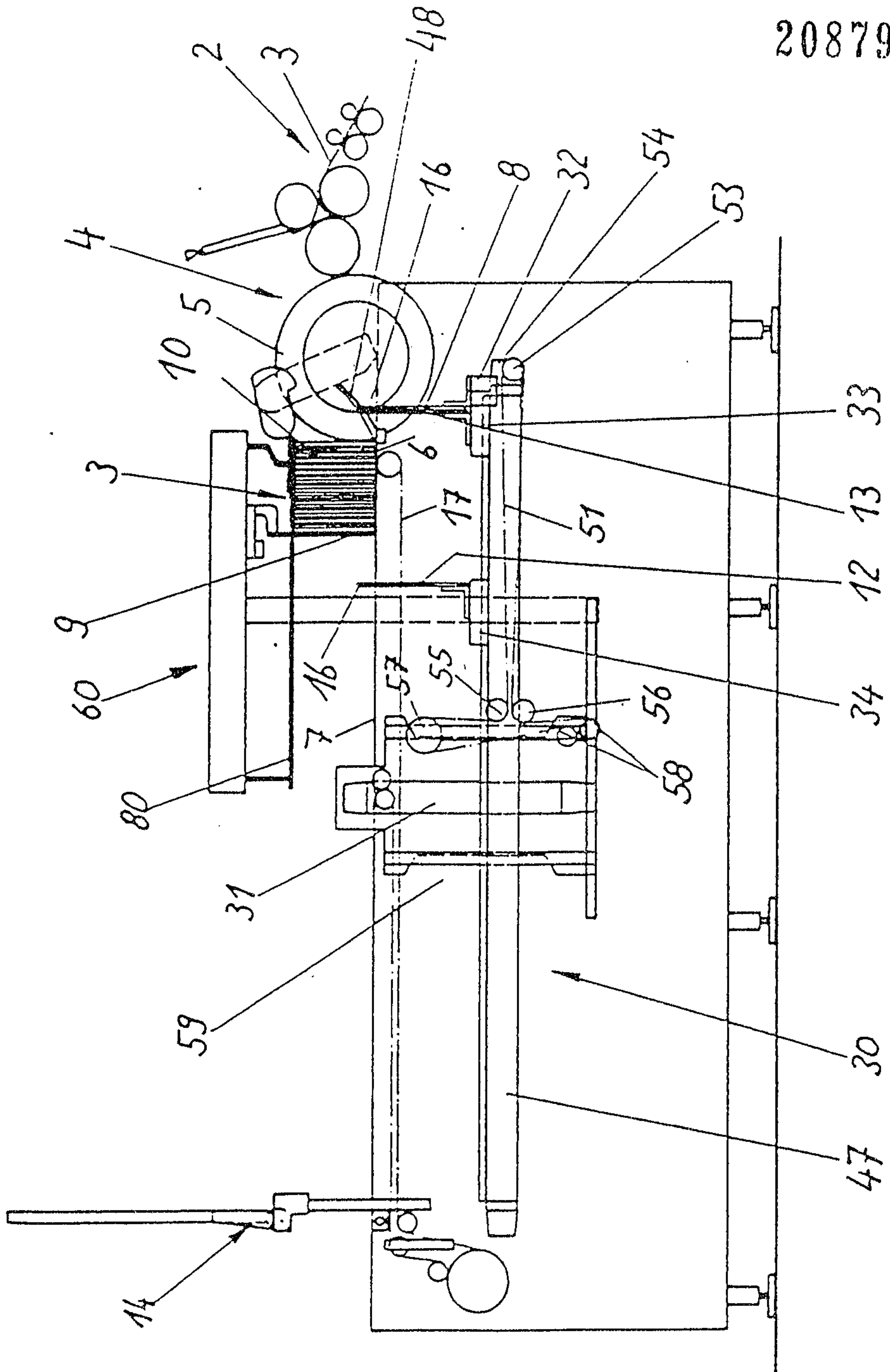

2/14

2087964

Fig. 2

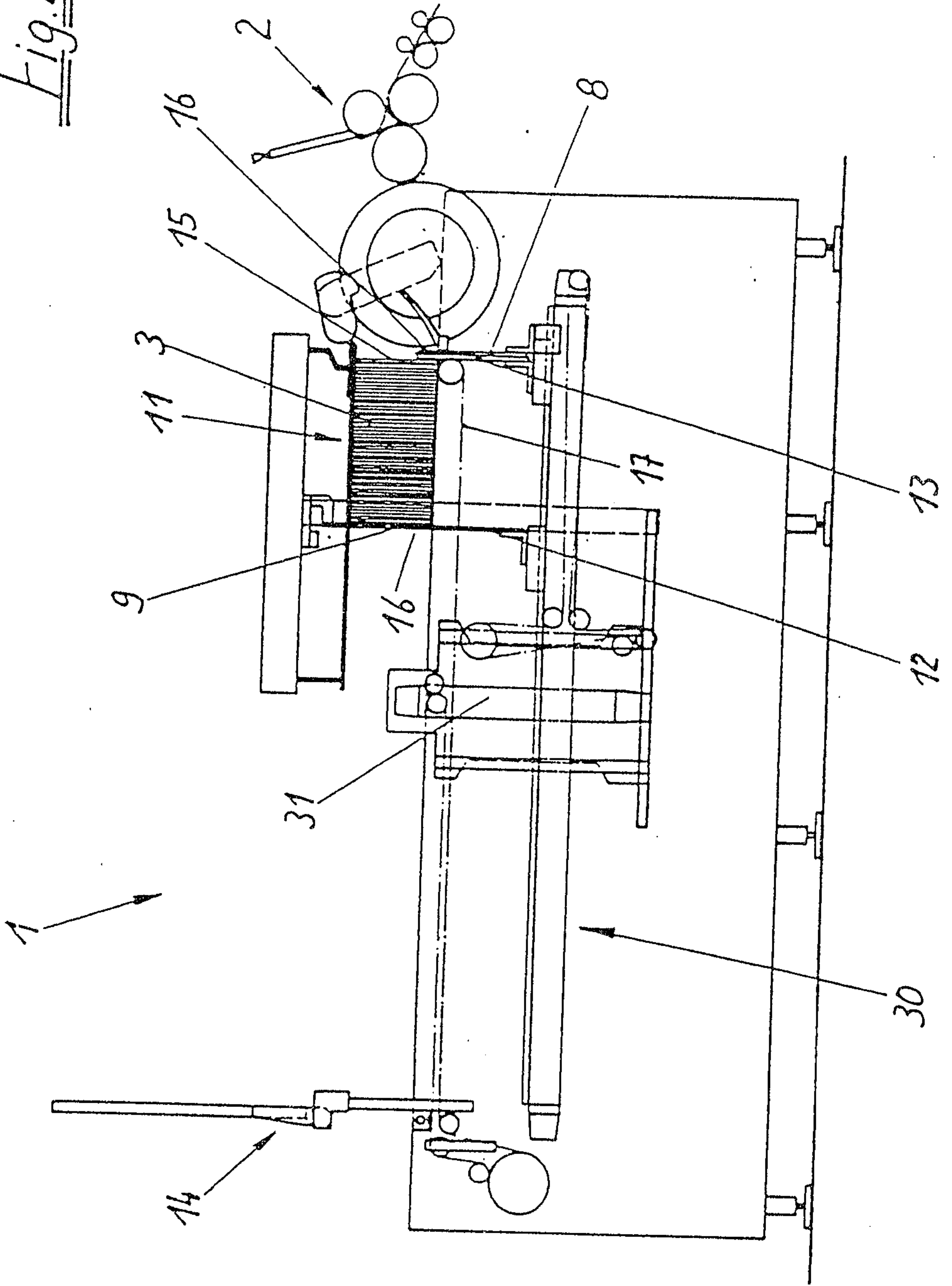

3/14

2087964

Fig. 3

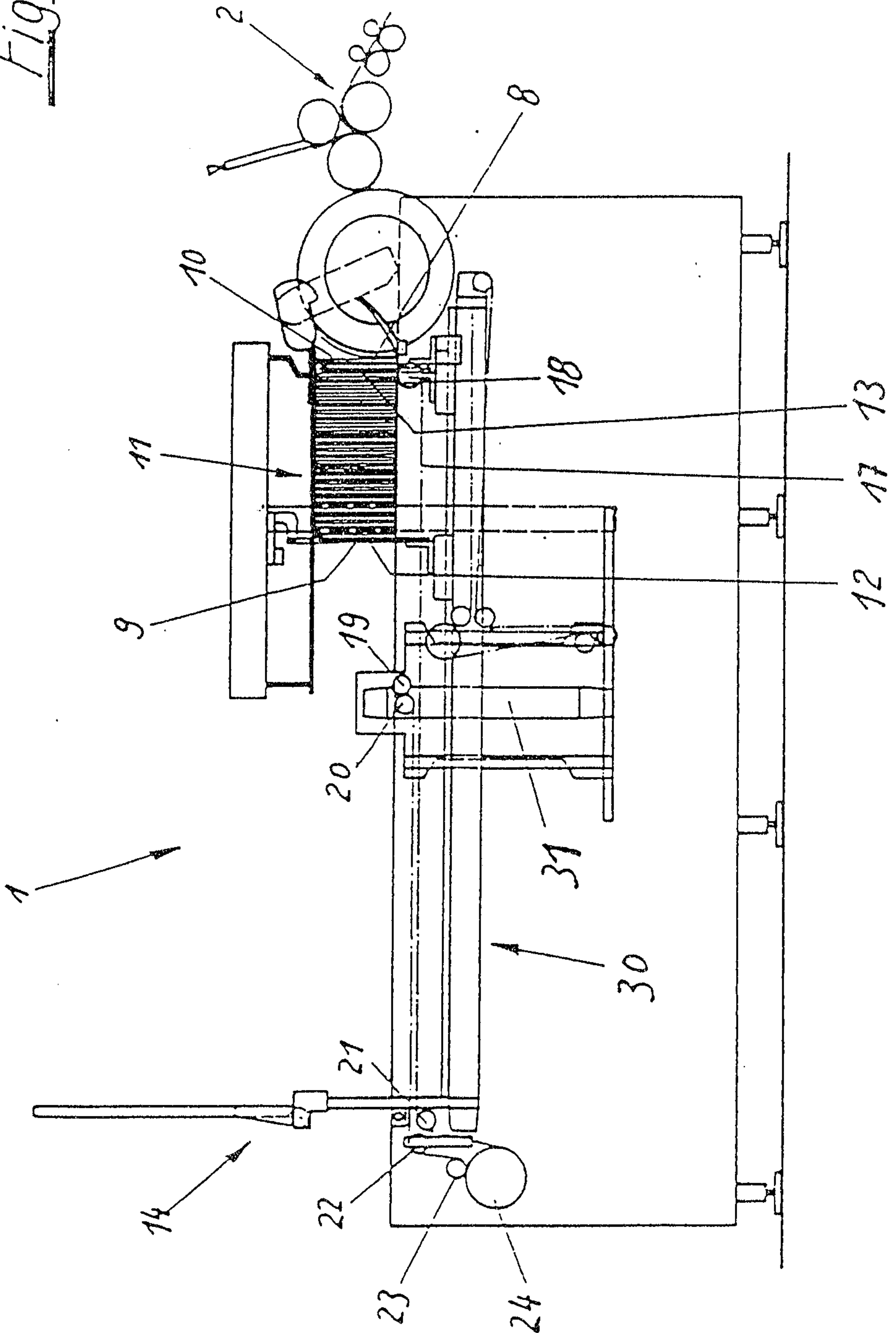
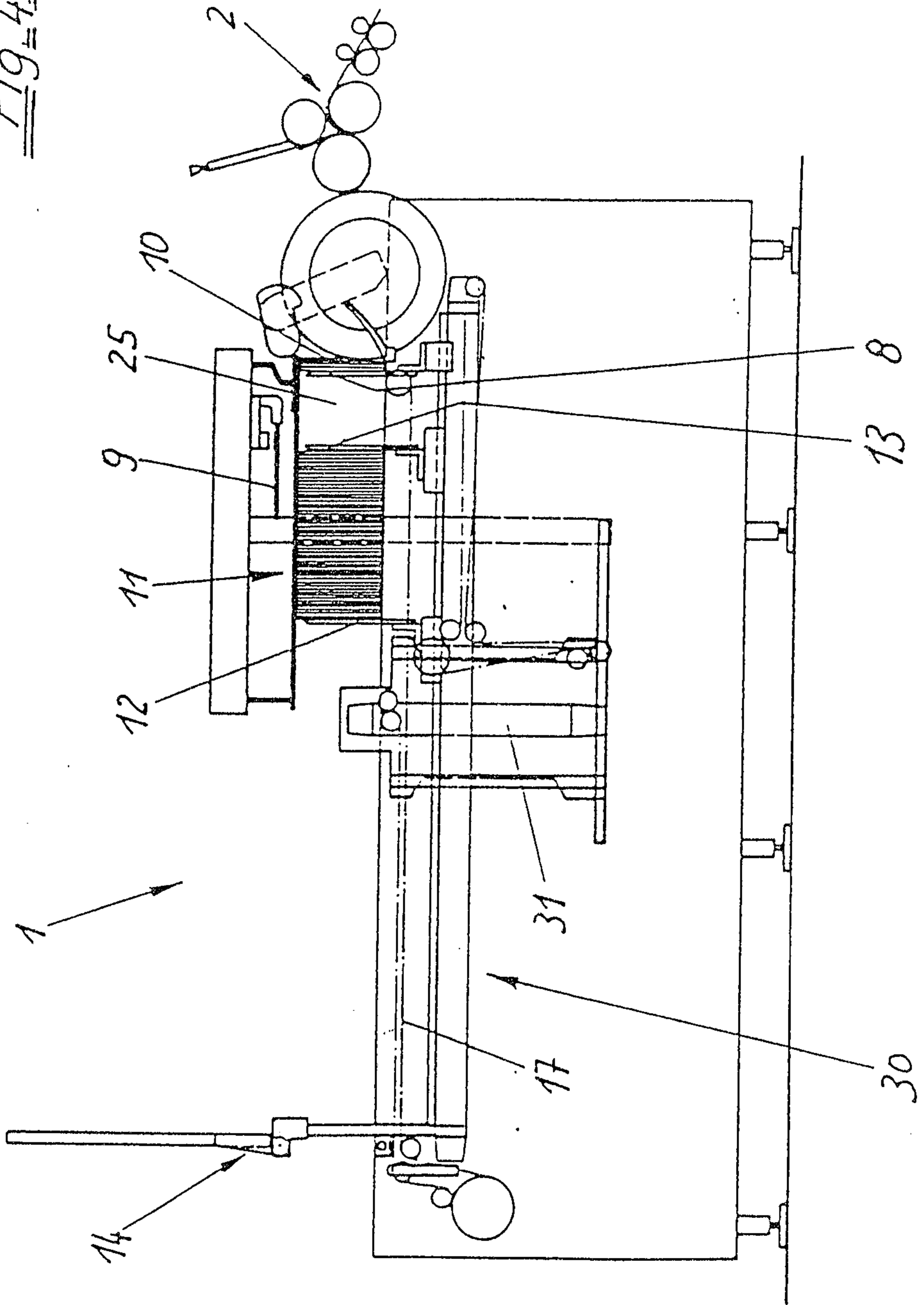
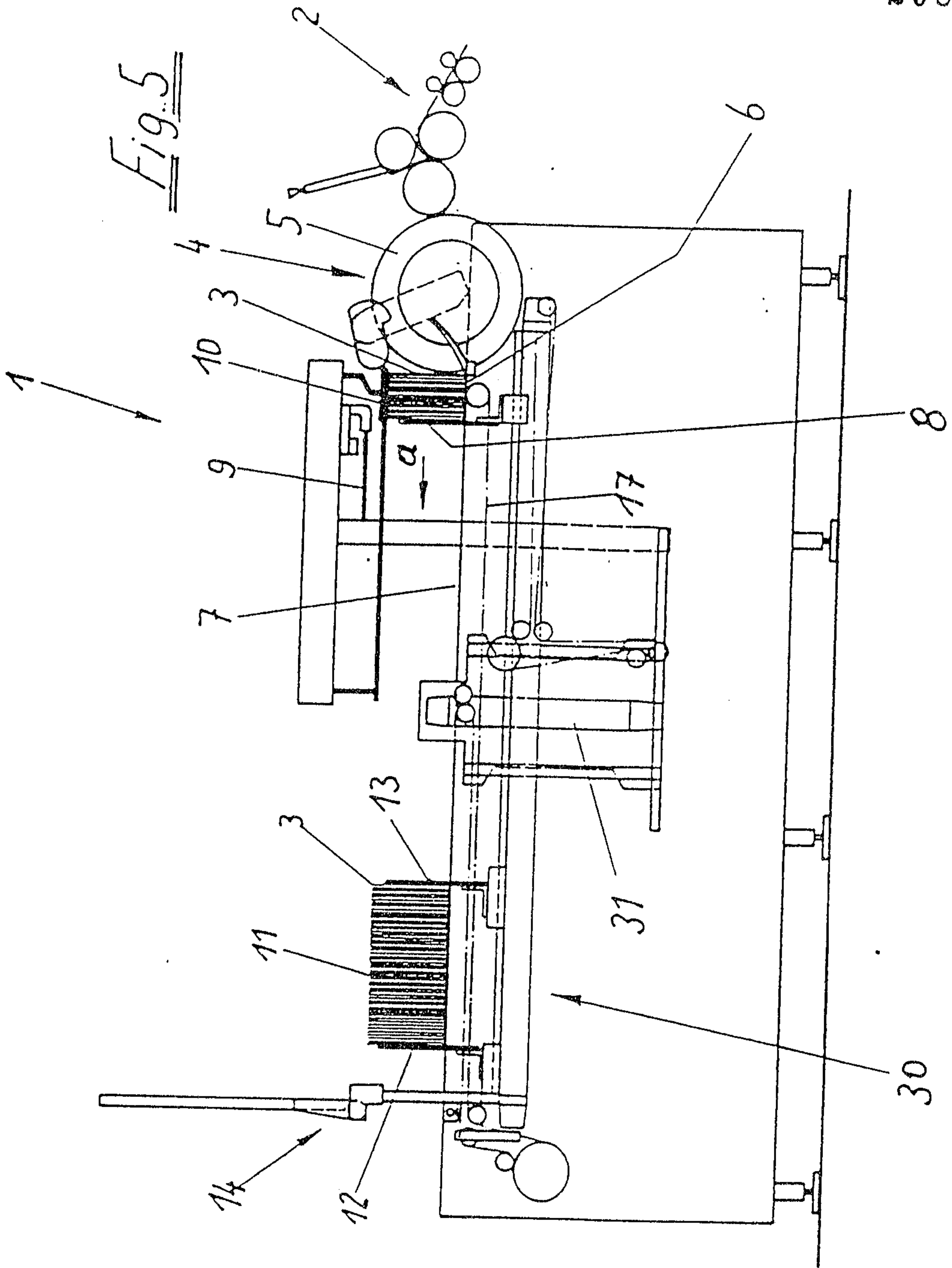

Fig. 4





6/14

2087964

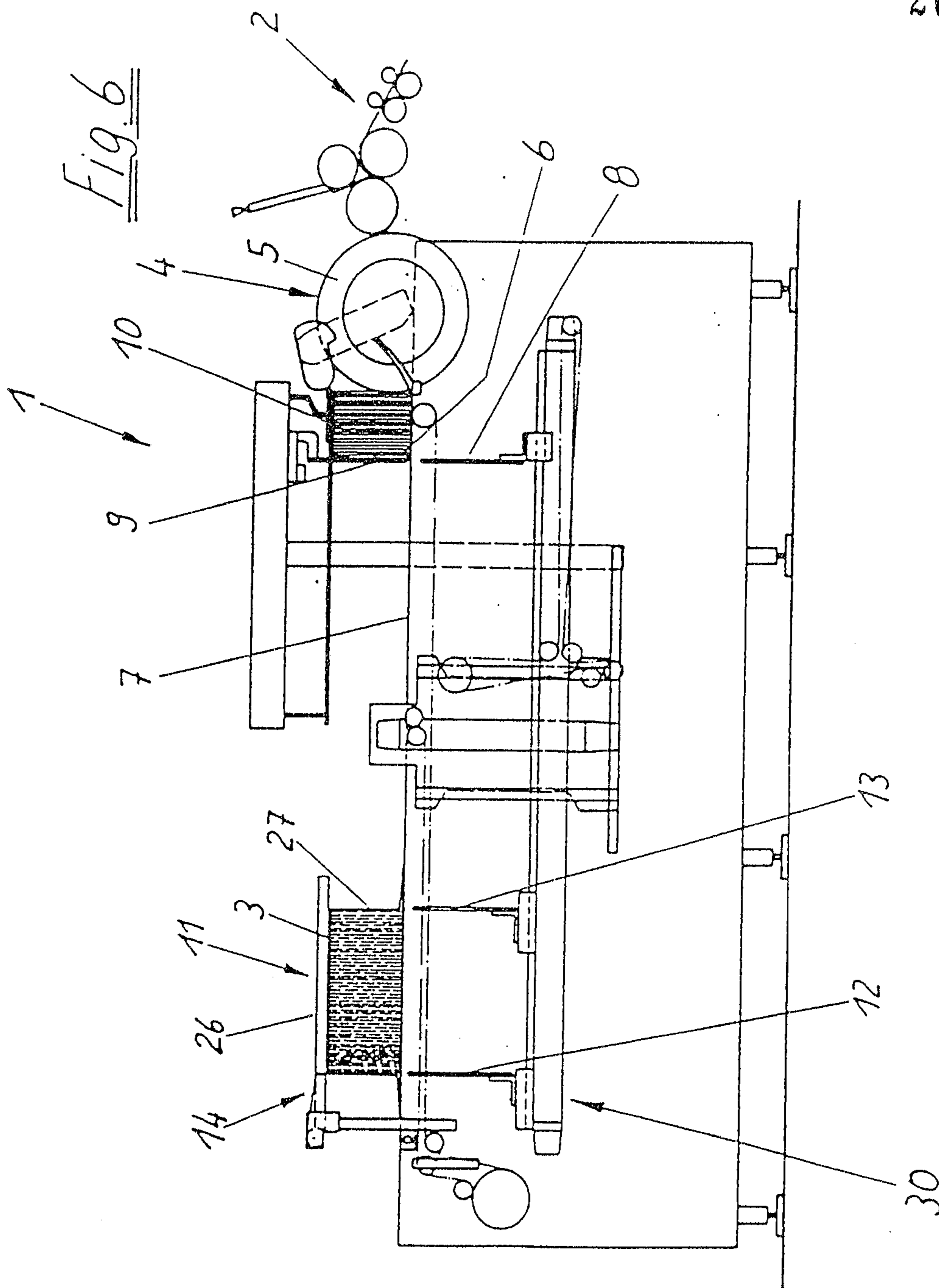

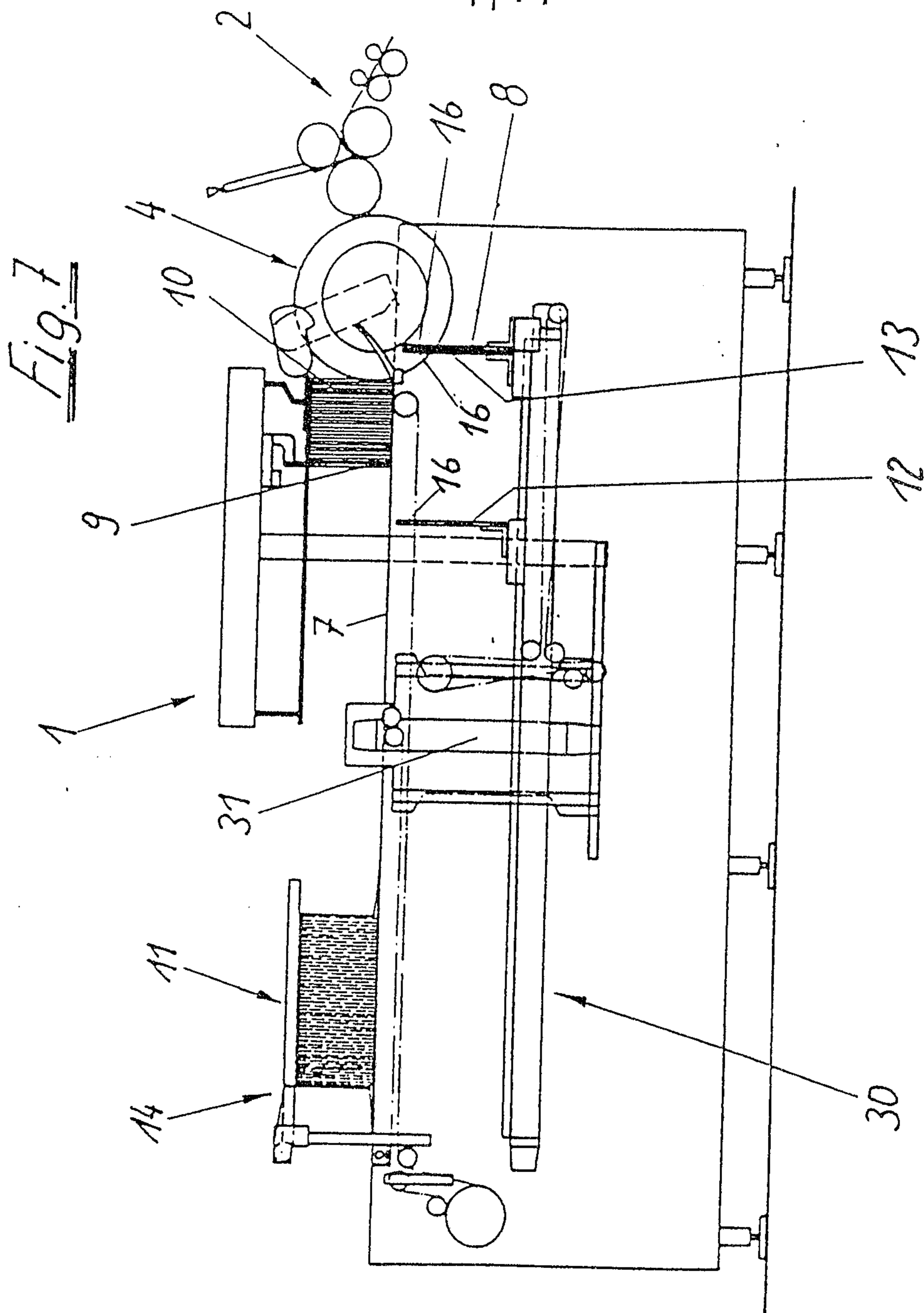

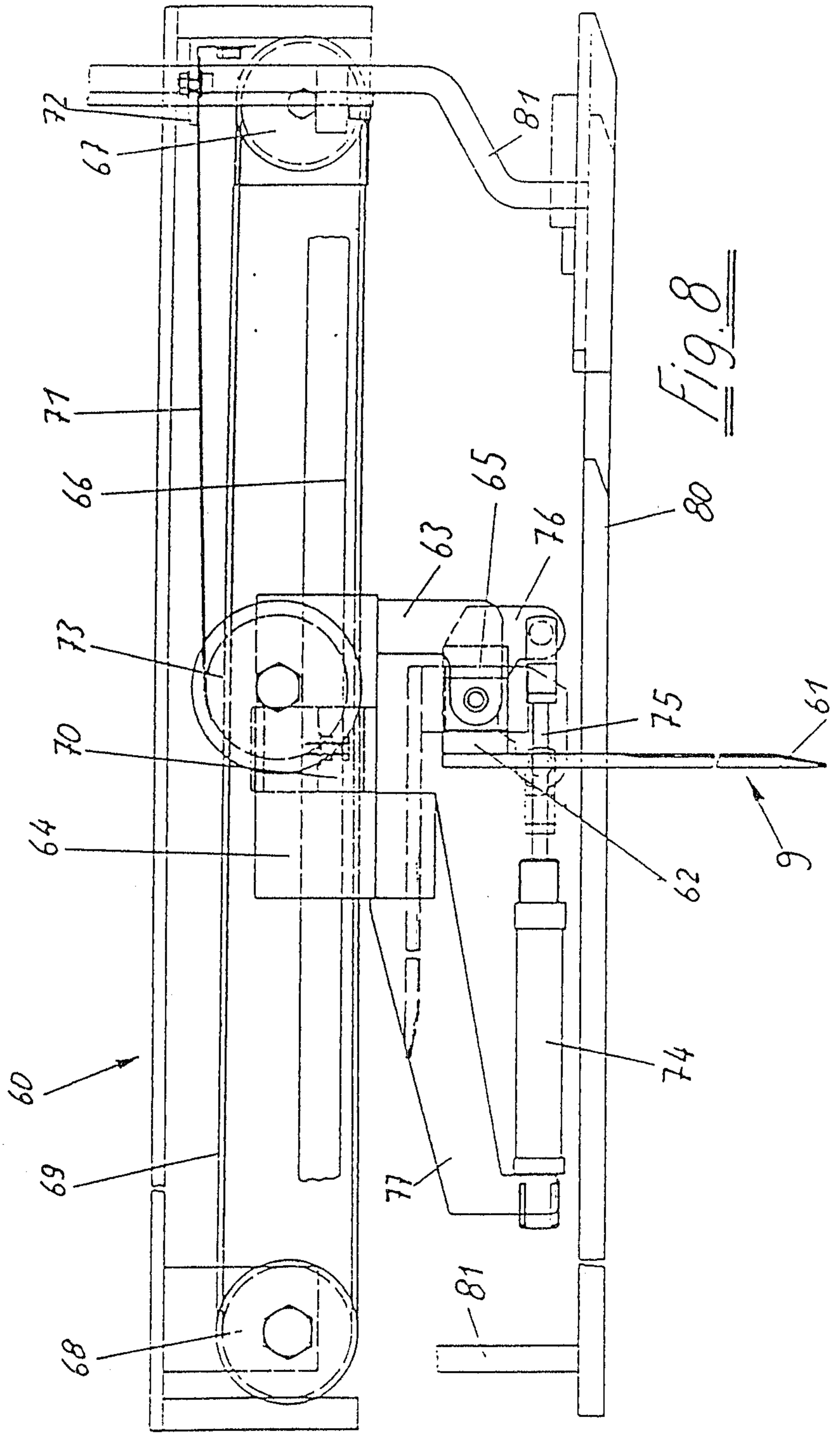
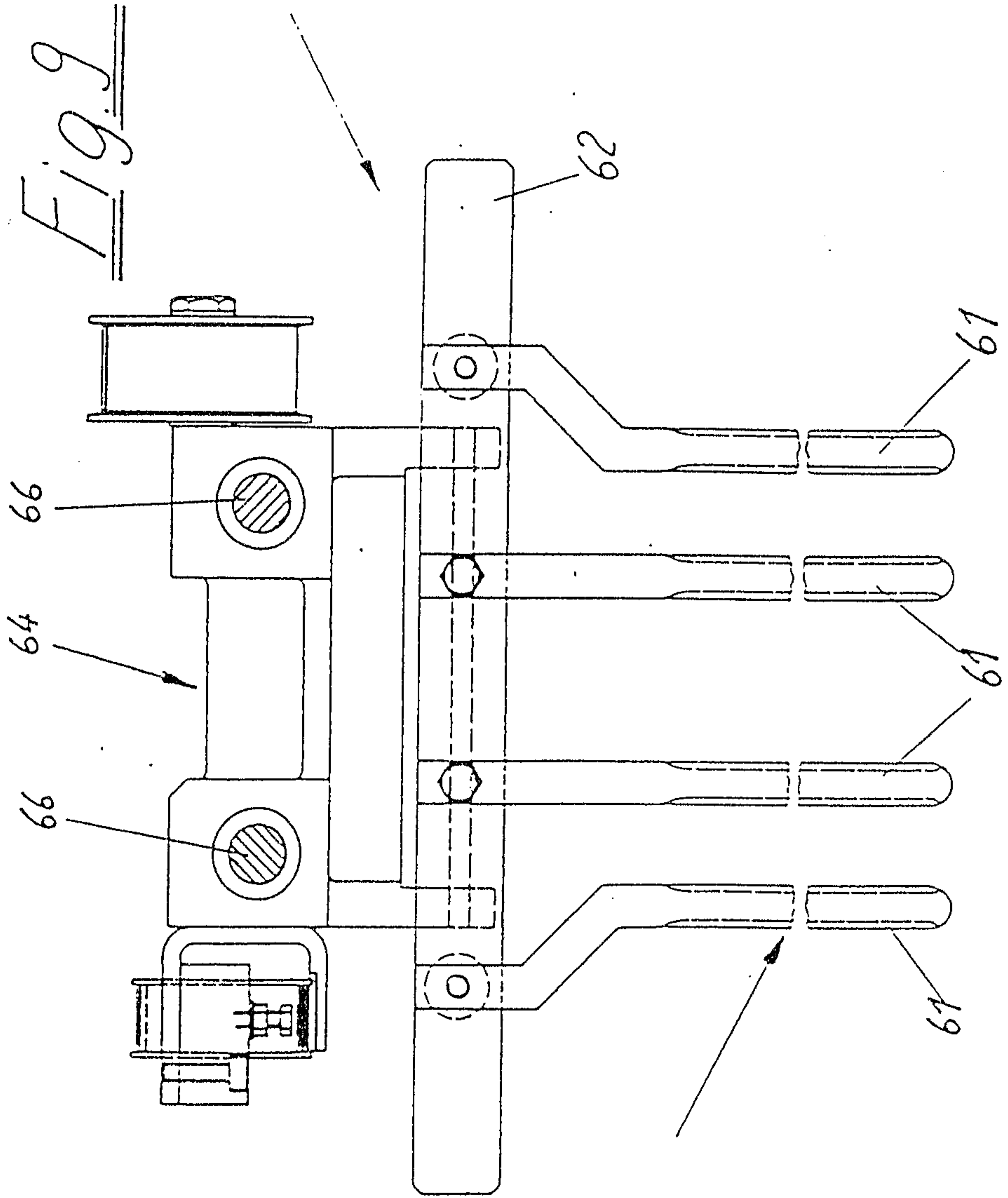

Fig. 8

9/14



9

10/14

FIG. 10

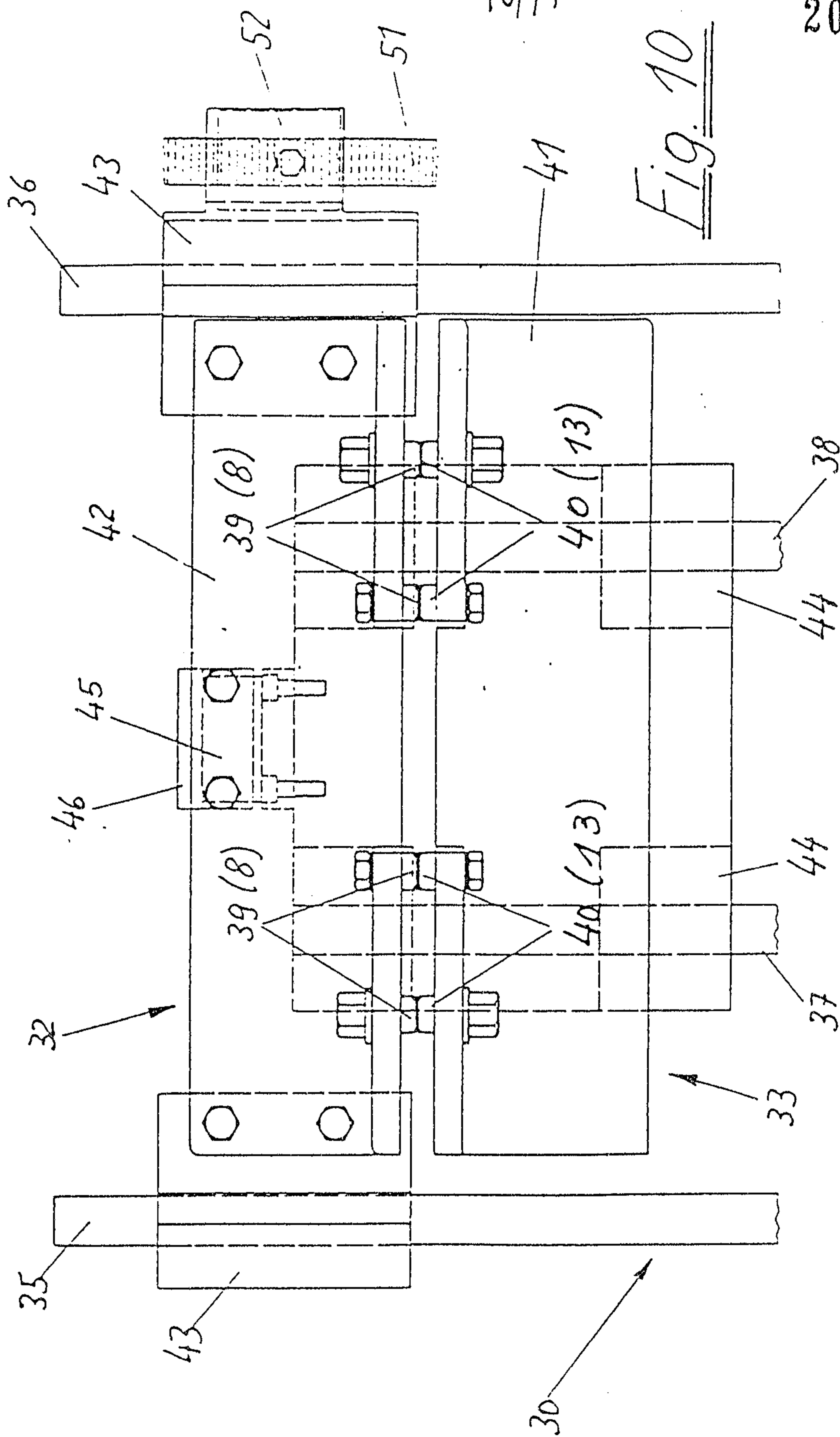

11/14

Fig. 11

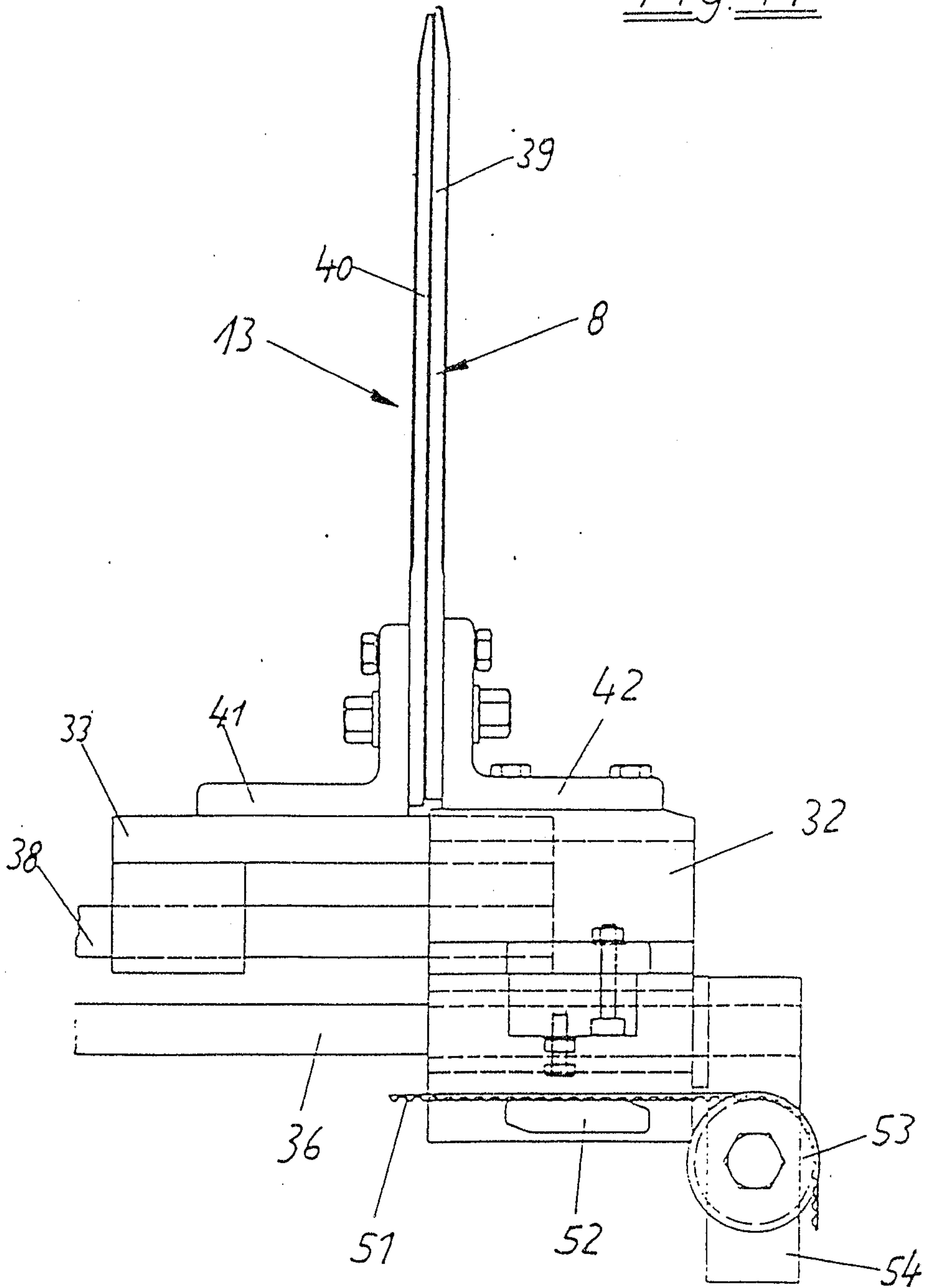

12/14

2087964

Fig. 12

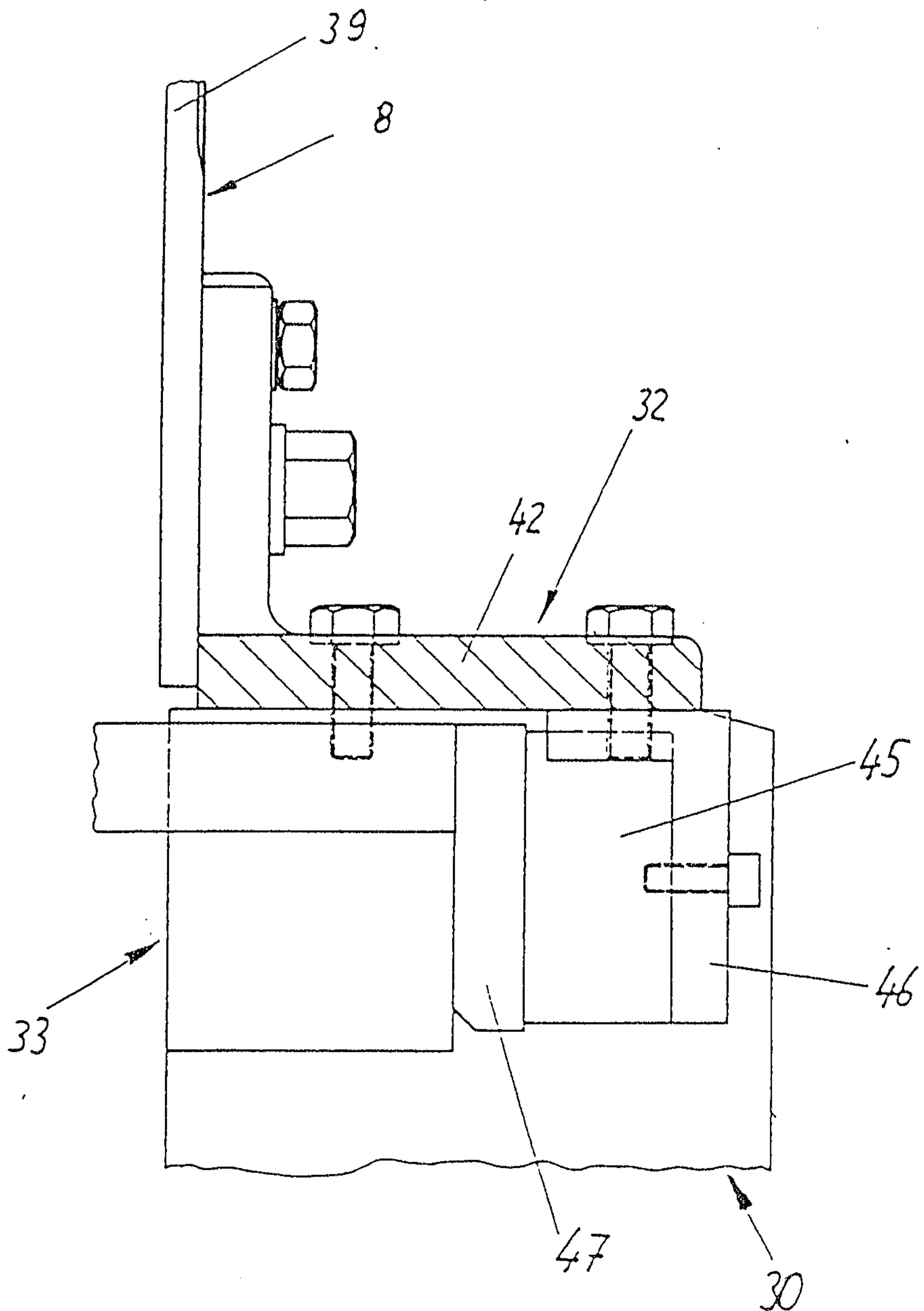
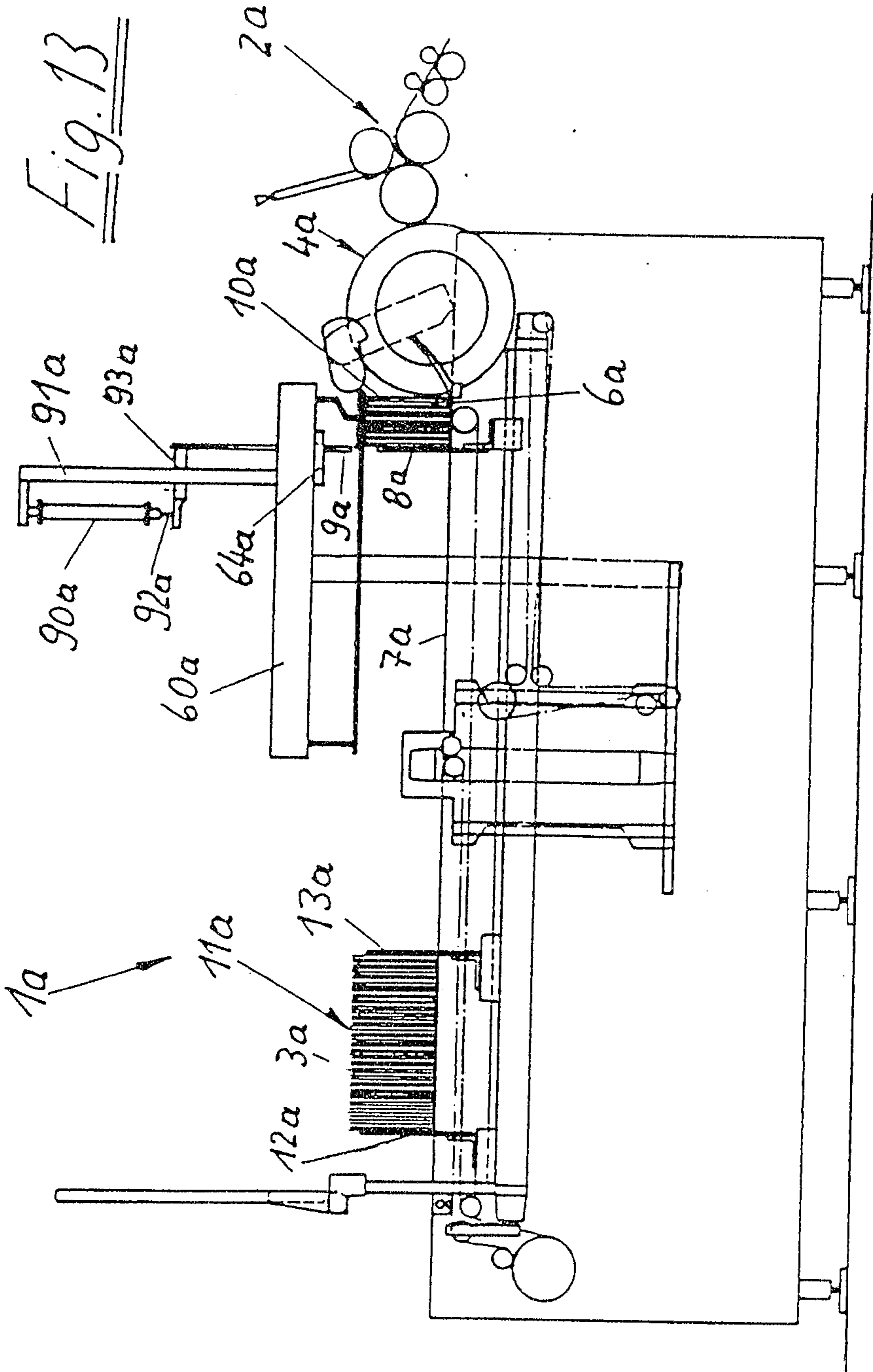

Fig. 13



14/14

